



DP/GP15N - DP/GP18N - DP/GP20CN

DP/GP20N - DP/GP25N - DP/GP30N

DP/GP35N

Specifications

Engine powered lift trucks

1.5 - 3.5 tonnes

DP/GP15-18N DP/GP20CN				DP/GP15N		DP/GP18N		DP/GP20CN	
Mast type	h3	h1	h4	h2/h5	Q @	h2/h5	Q @	h2/h5	Q @
	mm	mm	mm		c=500mm		c=500mm		c=500mm
Simplex	3000	1995	4050	80	1500	80	1750	80	2000
	3290	2140	4340	80	1500	80	1750	80	2000
	3700	2400	4770	80	1500	80	1750	80	2000
	4090	2585	5140	80	1500	80	1750	80	2000
	4480	2790	5530	80	1425	80	1700	80	1950
	5000	3050	6050	80	1375	80	1400	80	1400
	5500	3300	6550	80	1000	80	1000		
	6000	3550	7050	80	650	80	650		
Duplex	3000	1995	4050	945	1500	945	1750	945	2000
	3295	2140	4340	1095	1500	1095	1750	1095	2000
	3700	2400	4750	1355	1500	1355	1750	1355	2000
	4030	2585	5080	1535	1500	1535	1750	1535	2000
Triplex	3710	1795	4760	745	1500	745	1750	745	2000
	4010	1895	5060	845	1500	845	1750	845	2000
	4310	1995	5360	945	1425	945	1700	945	1950
	4750	2140	5800	1095	1375	1095	1625	1095	1900
	5090	2260	6140	1215	1325	1215	1325	1215	1325
	5490	2400	6540	1355	1000	1355	1000		
	5990	2585	7040	1535	650	1535	650		
	6490	2845	7540	1795	450	1795	450		
	7000	3050	8050	2005	275	2005	275		

Mast Performance and Capacity

- h1 Height with mast lowered
- h2 Standard free lift
- h3 Lift height
- h4 Height with mast raised
- h5 Full free lift
- Q Lifting capacity, rated load
- c Load centre (distance)

DP/GP20N - DP/GP25N				DP/GP20N		DP/GP25N		DP/GP30N				
Mast Type	h3	h1	h4	h2/h5	Q @	h2/h5	Q @	h3	h1	h4	h2/h5	Q @
	mm	mm	mm		c=500mm		c=500mm	mm	mm	mm		c=500mm
Simplex	3000	1995	4050	100	2000	100	2500	3030	2050	4090	100	3000
	3300	2145	4340	100	2000	100	2500	3270	2170	4330	100	3000
	3740	2410	4770	100	2000	100	2500	3700	2430	4760	100	3000
	4100	2590	5140	100	2000	100	2500	4000	2610	5060	100	3000
	4500	2800	5530	100	2000	100	2500	4500	2870	5560	100	3000
	5000	3050	6050	100	1950	100	2400	5000	3120	6060	100	2900
	5500	3300	6550	100	1850*	100	2250*	5500	3370	6560	100	2800
	6000	3550	7050	100	1800*	100	2150*	6000	3640	7060	100	2700
Duplex	3000	1995	4050	980	2000	980	2500	3000	2050	4060	1030	3000
	3300	2145	4340	1130	2000	1130	2500	3250	2170	4310	1150	3000
	3700	2410	4750	1390	2000	1390	2500	3700	2430	4760	1420	3000
	4020	2590	5080	1570	2000	1570	2500	4010	2610	5070	1600	3000
Triplex	3730	1800	4760	780	2000	780	2500	3690	1830	4750	810	3000
	4030	1900	5060	880	2000	880	2500	3990	1930	5050	910	3000
	4300	2000	5360	980	1950	980	2500	4320	2050	5380	1030	3000
	4750	2140	5800	1130	1900	1130	2400	4700	2170	5760	1150	3000
	5060	2260	6140	1250	1850	1250	2350	5060	2290	6120	1270	2900
	5500	2400	6540	1390	1800	1390	2200*	5450	2430	6510	1420	2800
	5990	2590	7040	1570	1750*	1570	2100*	5970	2610	7030	1600	2700
	6490	2850	7540	1830	1650*	1830	1750*	6470	2870	7530	1860	2350
	7000	3050	8050	2040	1250*	2040	1250*	7000	3070	8060	2060	1600

DP/GP35N					
Mast Type	h3	h1	h4	h2/h5	Q @
	mm	mm	mm		mm
Simplex	3000	2180	4060	100	3500
	3300	2300	4360	100	3500
	3720	2510	4780	100	3500
	4000	2770	5060	100	3500
	4500	3010	5560	100	3500
	5000	3260	6060	100	3500
	5500	3510	6560	100	3350
	6000	3760	7060	100	3250
Duplex	3010	2180	4070	1170	3500
	3300	2300	4360	1290	3500
	3720	2625	4780	1610	3500
	4000	2770	5060	1750	3500
Triplex	3730	1940	4790	930	3500
	4010	2060	5070	1050	3500
	4390	2180	5450	1170	3500
	4700	2300	5760	1290	3500
	5030	2450	6090	1430	3450
	5580	2630	6640	1610	3300
	6000	2770	7060	1750	3200
	6510	2940	7570	1930	2350
	7000	3140	8060	2120	1600

DP/GP15-20CN

All dimensions include load backrest. In case load backrest is not used h5 will increase by 410 mm, while h4 will decrease by 410 mm.

DP/GP20-35N

All dimensions include load backrest. In case load backrest is not used h5 will increase by 390 mm (20N, 25N), 350 mm (30N), 240 mm (35N), while h4 will decrease by 390 mm (20N, 25N), 350 mm (30N), 240 mm (35N).

The capacities are applicable for pneumatic shaped solid tyres (SE).

* Capacities shown require truck equipped with dual tyres. Consult your dealer for the maximum back tilt allowed, to obtain the capacities specified.

Cat Lift Trucks is renowned for its worldwide distribution network, but you will always find an experienced and dedicated team of professionals close to you. Individuals committed to helping you maximise profits.

With Cat Lift Trucks, your investment is in safe hands.

Cat® Lift Trucks.

Your partner in materials handling.

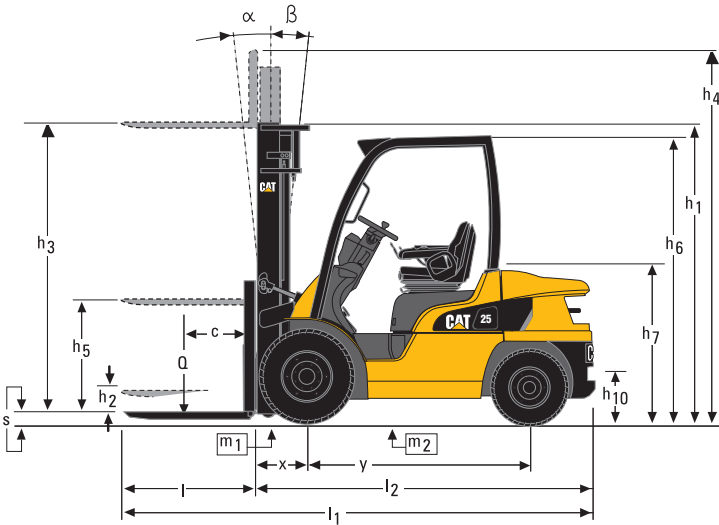

Capacity vs. Load Distance

Simplex - h3 = 3290 mm

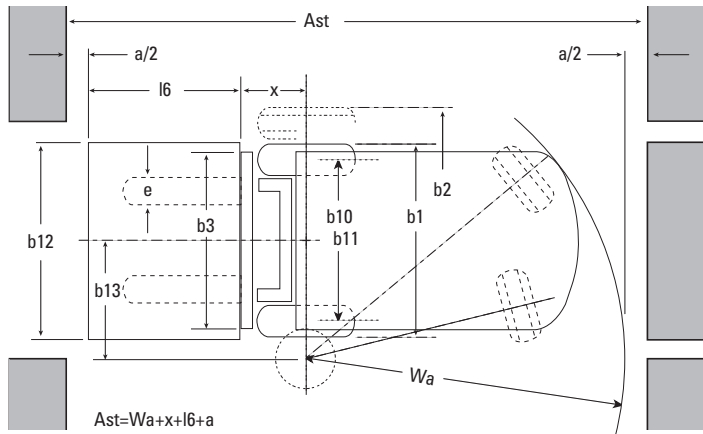
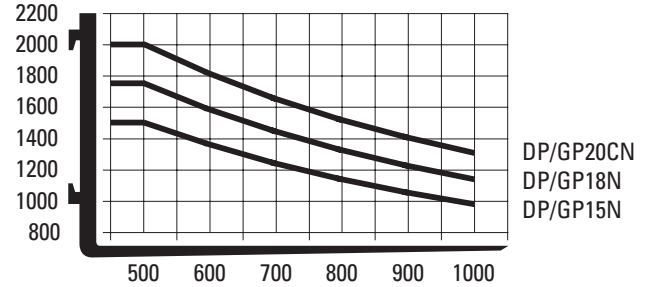

Capacity vs. Load Distance

Simplex - h3 = 3290 mm

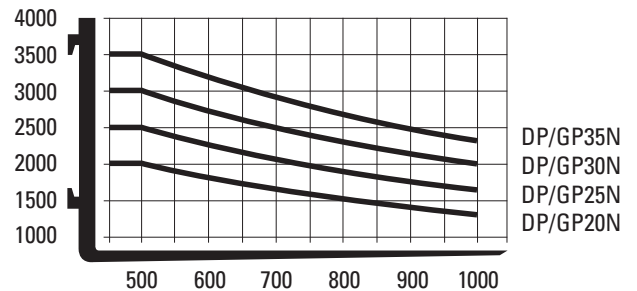

- Ast = $Wa + x + l6 + a$
- Ast = Working aisle width with load
- a = Safety clearance (200 mm)
- l6 = Pallet length (800 or 1000 mm)
- b12 = Pallet width (1200 mm)

info@catliftruck.com
www.catliftruck.com

CESC1091(06/09)ok
 Copyright ©2009, MCFE. All rights reserved.
 CATERPILLAR, CAT, their respective logos,
 'Caterpillar yellow' and the 'Power Edge' trade dress,
 as well as corporate and product identity used herein,
 are trademarks of Caterpillar and may not be used
 without permission.
 Printed in The Netherlands

NOTE: Performance specifications may vary depending on standard manufacturing tolerances, vehicle condition, types of tyres, floor or surface conditions, applications, or operating environment. Trucks may be shown with non-standard options. Specific performance requirements and locally available configurations should be discussed with your Cat lift trucks Dealer. Cat Lift Trucks follows a policy of continual product improvement. For this reason, some materials, options and specifications could change without notice.

