

# **REMKO PGT**

## **Propane gas heater**

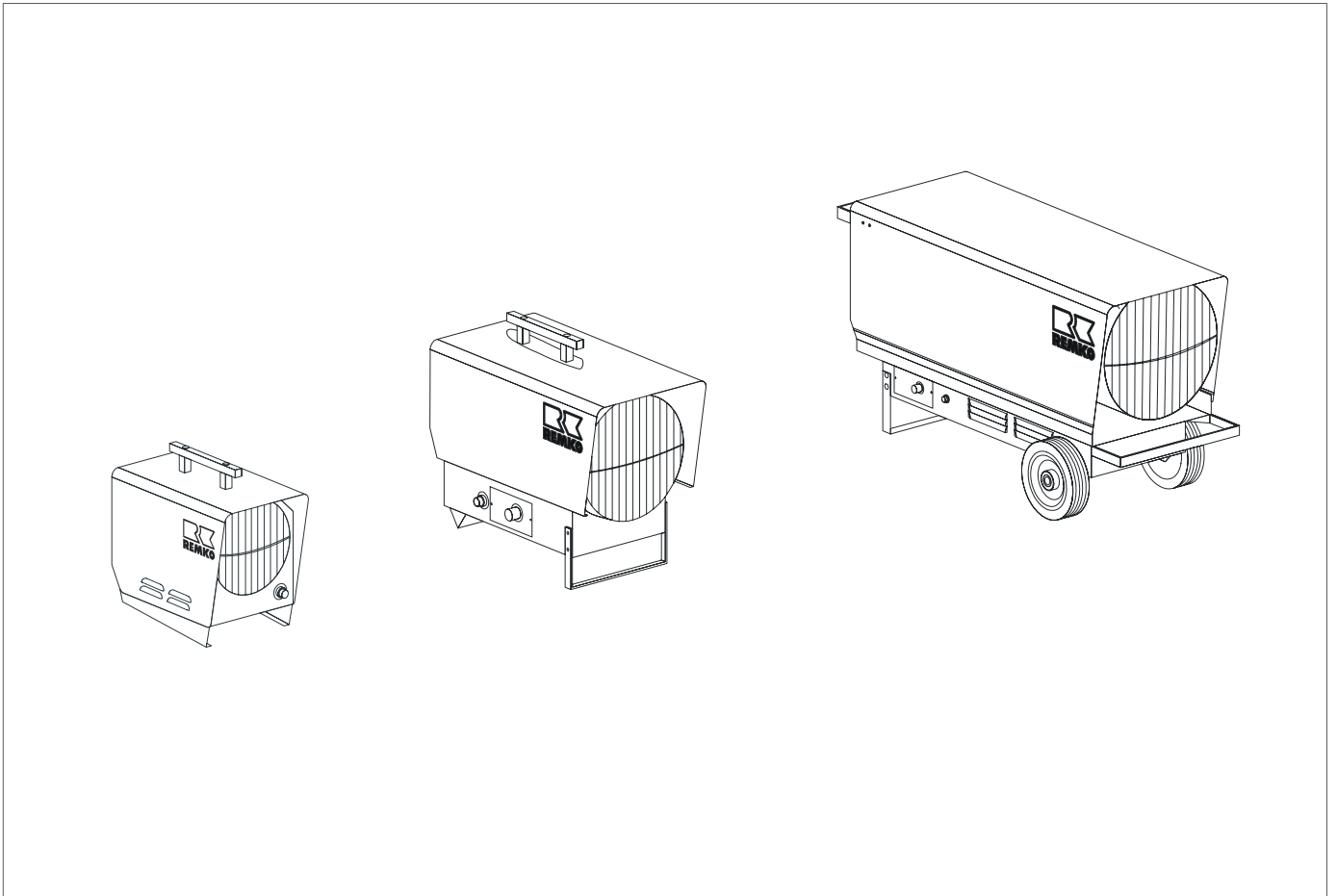

**Operation**  
**Technology**  
**Spare Parts**



# Operating instructions

Read these instructions carefully before setting up/operating the unit!

Our guarantee becomes null and void if the unit is used, set up or maintained improperly, or if modifications are made to the supplied unit without our prior consent.  
Subject to alterations!

## Mobile propane gas heater

**REMKO PGT 30 / 30 E**

**REMKO PGT 60 / 60 E**

**REMKO PGT 100 / 100 E**

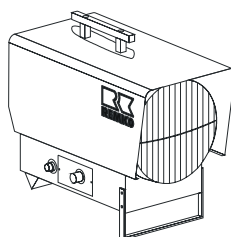

<b>Contents</b>	Page	<b>Contents</b>	Page
Safety Instructions	4	Wiring Diagram	10
Description of the Unit	4	Technical Data	11
General Instructions	5	Exploded View PGT 30 / 30 E	12
Before Starting	5	Spare Part List PGT 30 / 30 E	13
Gas Supply	6	Exploded View PGT 60 / 60 E	14
Starting	7	Spare Part List PGT 60 / 60 E	15
Unit Shut Down	8	Exploded View PGT 100 / 100 E	16
Safety Mechanism	8	Spare Part List PGT 100 / 100 E	17
Maintenance	8	Troubleshooting	18
Service and Guarantee	9	Maintenance Log	19



Always keep these operating instructions near or on the unit!



## Safety Instructions

Make sure to observe relevant local building and fire protection codes and abide by professional association regulations when the unit is in operation.

Please also observe the following.

The unit may only be operated by persons who have received proper training in its operation.

The units must be installed and operated in such a way that people are not exposed to radiant heat and fires cannot occur.

The units may only be installed and operated in closed rooms where the units have an adequate air supply for combustion.

The portable liquid gas tanks must be set up securely in an upright position.

During unit operation, the portable liquid gas tanks may never be used while they are lying on their sides. *Danger of explosion: liquid gas may leak out of the gas nozzle.*

The unit may only be operated in well-ventilated rooms.

Persons may not remain in the room where the unit has been installed for longer periods of time. *Warning signs must be placed at the entrances.*

The unit may only be set up and operated on a non-flammable surface.

Make sure that no flammable objects/materials can be sucked in to the unit.

The unit may not be set up or operated in surroundings susceptible to fire or explosions.

A safe distance off 1.5 m must be maintained around the unit; a distance of 3 m must be maintained from its exhaust opening, even for non-flammable objects.

The unit's exhaust opening may not be reduced in size or equipped with hoses or pipes.

Never insert foreign objects into the unit.

The air suction grille must always be kept free of dirt and loose objects.

Do not expose the unit to a direct stream of water.

All electric cables outside the unit are to be protected from damage (e.g. caused by animals, etc.).

Before performing any maintenance or repair work, make sure to unplug the unit from the power supply and disconnect it from the fuel supply.

 **Do not bypass or block safety mechanisms while the unit is in operation.**

## Description of the Unit

The unit is directly fired with liquid gas in a gaseous state. The unit works without an exhaust connection and has been designed for automatic, universal and smooth operation.

The unit is equipped with: an integrated power regulation to gradually adjust the heating capacity, a robust flame burner, an electrical solenoid valve, a quiet axial fan requiring little maintenance, an ionisation monitoring mechanism, electrical ignition, room thermostat socket and connection cable with plug.

The unit meets the basic safety and health requirements of the relevant EU regulations.

The unit has been tested for conformance to EU prototypes, it is safe and easy to operate.

### Areas of Application

to dry new buildings

to provide localised heat for outdoor workplaces or localised heat in production rooms and halls not susceptible to fire.

to permanently or temporarily heat closed and open rooms that have sufficient fresh air intake

to de-ice machines, vehicles and non-flammable stored goods and regulate the temperature of components susceptible to frost.



**For optimum unit operation, the device should not be operated at an ambient temperature above 25 °C.**

### Unit Functionality

The air supply fan is put into operation by setting the operating switch to "I". The burner also begins his program.

After a few seconds, the electrical solenoid valve opens the gas supply to the burner. The liquid gas is supplied to the burner pipe through a pressurised nozzle where enough oxygen is added to meet the respective burner capacity.

The resulting gas-air-mixture is ignited on the burner head by an electric ignition spark. The ignition is automatically ended once a proper flame is burning and the burner has started to monitor the flame.

All unit functions are automatically performed and safely monitored by the burners that are secured against low voltage.

If the flame burns unevenly or goes out, the unit is switched off by the burner. The malfunction light of the burner lights up. The unit can only be restarted after the burner has been manually released.

The safety temperature limiter (STB) interrupts the gas supply and locks all functions if the unit overheats. The STB can only be manually released after the unit has cooled.

The min/max heat output can be gradually with the "power regulation" function during unit operation.

# General Instructions

The unit may only be operated by persons who have received proper training in its operation and how to handle liquid gas.

When operating the unit, make sure to comply with the relevant national/regional guidelines.

The unit may only be operated in rooms

- with sufficient air supply for combustion
- that are well-ventilated
- where the quantities of substances which can be harmful when breathed in are admissible.

Good natural ventilation exists when, for example:

1. The room content in m<sup>3</sup> equals 30 times the rated heat output of all units in operation in the room and natural ventilation is supplied through doors and windows or
2. There are non-closable openings for air output and intake close to the ceiling and floor whose size in m<sup>2</sup> equals at least 0.003 times the rated heat output in kW of all heating units in operation in the room.

A standard unit connection pressure of **1.5 bar (1500 mbar)** of category I<sub>3B/P</sub> is required for all EU countries.

The connection pressure may not fall below or exceed the required value.

When longer hoses are used, the corresponding pressure loss has to be taken into account.

Use only those parts, such as gas hoses, pressure controller and mechanisms which protect lines and hoses from breaking and safety mechanisms that prevent gas leakage, that have been tested and are suitable for the intended purpose.

The pressure controllers must have a fixed initial pressure of 1500 mbar and must be equipped with a mechanism that prevents the hose from breaking.

The unit may not be operated if the gas is in a liquid state as it enters the burner.

At building sites, only hoses designed for use with liquid gas may be used.

*In accordance with regional regulations.*

The length of the gas hose should not exceed 2 metres.

Longer hoses may be used if safety regulations are observed and the length of the hoses is kept as short as possible.

Gas hoses must be protected against chemical, thermal and mechanical damage.

If unit operation is unmonitored, hoses must be used that protected against breakage.

Prior to operating the unit, the operating personnel must check that the unit and its safety mechanisms are functioning properly and that the safety mechanisms have not been removed.

Any defects are to be reported to the supervisor immediately.

The unit must be switched off if any defects are found which endanger the safe operation of the unit!

The unit may be only serviced by authorised personnel; only original spare parts may be used.

Parts that wear out must be replaced on a regular basis unless an authorised service person confirms that the unit is functioning smoothly.

If the unit has been switched off by the temperature limiter due to overheating, the reason the problem occurred has to be identified and fixed.

 **If work is performed on the gas supply hose or if the gas cylinder is replaced, all stop valves must be closed and nothing which can potentially ignite may be present in the immediate surroundings.**

## Before Starting

Only individuals who have been sufficiently trained in the respective area may operate the units and monitor the containers and storage of the cylinders.

Make sure that the operator is aware of potential dangers when handling liquid gas.

Prior to operation, the operators must check the units' operating and safety mechanisms for any visible defects and ensure that the safety mechanisms have not been removed.

### Important Information

The unit may only be installed in well-ventilated rooms; it may not be installed in residential living rooms or similar spaces!

A constant unit connection pressure of 1.5 bar (1500 mbar) must be maintained even when the unit is in continuous operation.

If the unit is operated at a building site, only hoses designed for this purpose may be used.

Clean the gas supply hose thoroughly before operating the unit for the first time.

 **For optimum unit operation, the device should not be operated at an ambient temperature above 25 °C.**

# Gas Supply

Connect the gas hose as follows:

1. Connect the pressure controller to the gas cylinder(s).

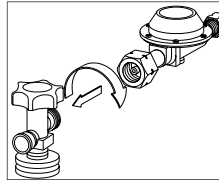

**Caution!**  
Left-handed thread!

2. Open cylinder(s) valve(s).  
*When gas is removed from several gas cylinders simultaneously, all the valves have to be opened.*

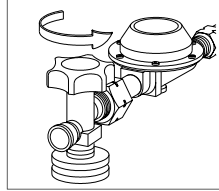

3. Press the release button of the hose protection mechanism **after opening** the valve(s).  
*This must be done each time the cylinders are replaced.*

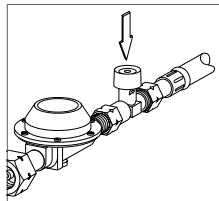

4. After installing and connecting the units, check all gas connections to make sure they are tight.  
*Soap solution, leak detection spray etc.*  
**Do not use open flames!**

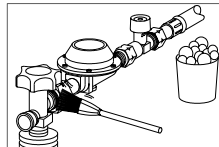

## Important Information about Installation

When installing or removing the gas hose, make sure to exert counterpressure on the unit's gas connection nipple using an open-end spanner SW 19 and remembering that the thread is left-handed.

This process also applies to all other gas components, including the pressure controller, hose protection device (against breakage), etc.

Unscrew gas hose

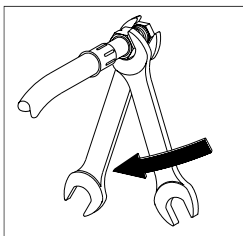

Turn union nut clockwise

Fasten gas hose

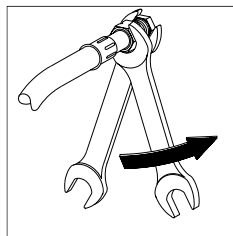

Turn union nut counter-clockwise

**Install gas tanks only in well-ventilated rooms; they may not be set up in rooms where people reside for longer periods!**

## Important Safety Instructions

The gas tanks may not be placed directly behind the unit!

Never heat up or de-ice the gas tank using the hot air coming out of the unit.  
*Danger of explosion.*

Never place the gas tank on its side when the unit is in operation.  
*Danger of explosion.*

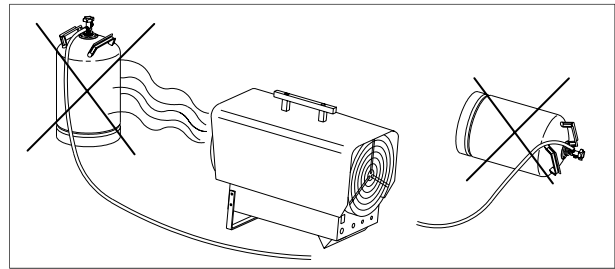

## Important Information about Ice Formation on the Gas Supply System

There is a danger that ice will form on the gas or pressure tanks if the dimensions of the gas supply system are insufficient. When the gas pressure falls, it is no longer possible to ensure that gas is properly supplied to the consumer system.

This can result in imperfect combustion or harmful exhaust fumes, or may cause the flame to go out.

The frost crystals may not be removed using an open flame, burning embers or radiators.

The gas supply system is to be set up in accordance with the unit's connection value (see type plate), length of operation and ambient temperature of the supply tanks.

In general, we recommend that using a set of at least 3 cylinders to prevent heavy ice formation on the tanks. The number of cylinders can be increased using a multi-cylinder set (accessories) depending on the unit capacity and the length of operation.

## Assembly of Multi-Cylinder Set

All cylinder valves must be open to ensure constant gas supply!

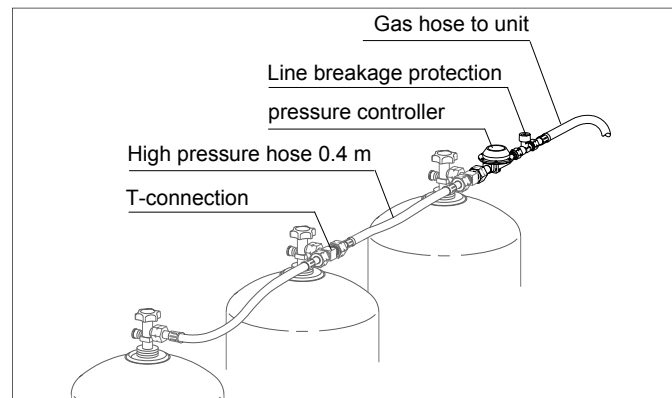

# Starting

When operating units, the respective and relevant local guidelines must be observed.

You must also observe these additional instructions:

Only people who have been adequately trained in operating the units may be placed in charge of their operation, with monitoring of the containers and cylinder storage.

Make sure that the operator is aware of potential dangers when handling liquid gas.

The unit may only be installed in well-ventilated rooms; it may not be installed in residential rooms or similar spaces!

For optimum unit operation, the device should not be operated at an ambient temperature above 25 °C.

The unit must be connected to the power supply via a special supply point with fault current safety switch.

Make sure to maintain a safe distance to combustible and flammable materials and comply with local fire codes.

## Connecting the unit to the power supply

1. Set the operating switch to "0".  
*Off.*
2. Plug the unit in to a power socket with the right connection.  
*230V/1~ / 10A / 50Hz*
3. When connecting the unit to the power supply, make absolutely sure that the polarity is correct!
4. If the unit should switch off due to a malfunction during the start phase, turn the plug 180°.

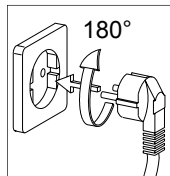
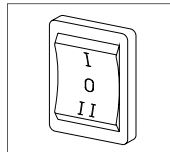

## Heating without a room thermostat

The unit runs in continuous operation.

1. Plug the supplied bridge circuit plug **2** into the thermostat socket **1** of the unit.
2. Set the operating switch to "I".  
*Heating mode.*
3. Please note: the air supply fan starts, the burner controls and monitors the program automatically.  
*The flame forms after approx. 15 seconds.*

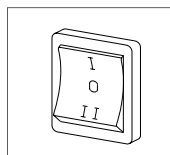
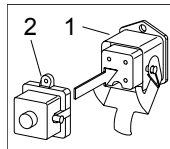

## Automatic heating with room thermostat

The unit runs automatically with the temperature which has been pre-selected on the room thermostat.

1. Remove the bridge circuit plug **2**.
2. Plug the thermostat plug **3** of the room thermostat (accessories) into the thermostat socket **1**.
3. Put room thermostat **4** in a suitable place.  
*The thermostat sensor may not be placed directly in the warm air stream or attached to a cold surface.*
4. Pre-select desired room temperature on the room thermostat.
5. Set the operating switch to "I".  
*Heating mode.*
6. Please note: the air supply fan starts, the burner controls and monitors the program automatically.  
*The flame forms after approx. 15 seconds.*

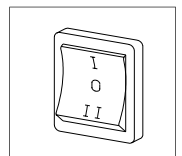
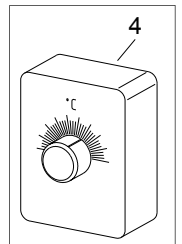
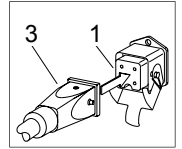

## Setting and regulating the heat output

1. Set the heat output gradually using the adjustable "power regulation".
2. Please note: this setting can also be gradually changed while the unit is in operation.

**Turn to the left:**  
Increases heat output

**Turn to the right:**  
Lowers heat output

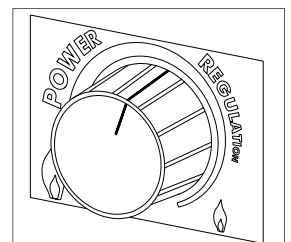

## Important Information

Make sure that the air supply can be freely suctioned in and the heated air blown out.

The unit's air intakes and outlets may not be constricted or equipped with hoses or pipes.

## Ventilation

In ventilation mode, only the air supply fan runs and the unit can be used for air circulation.

1. Set operating switch to "II".
2. Please note: it is not possible to heat!

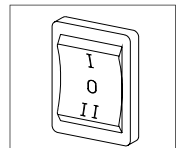

## Unit Shut Down

1. Close all cylinder valves.
2. Let the flame burn out.
3. Set the operating switch to "0".  
*Off.*
4. Unplug the unit plug from the power supply.

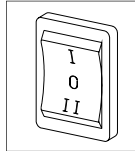
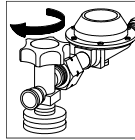

### Important instructions for the cool down phase for units whose fans continue to run automatically (PGT 100 / 100 E).

The fans keep running automatically to prevent heat from building up inside the unit which, in turn, keeps the STB from being triggered after the burner is switched off.

For this reason, the electrical connection may not be separated from the power supply before the fans have stopped running except in emergency situations.

## Safety Mechanism

Should overheating occur, the safety temperature limiter (STB) interrupts the gas supply and locks the unit's electrical system. All unit functions are switched off.

"RESETTING" is not possible before the sensor has cooled down to below approx. 90 °C.

The unit is released once the protective cap has been unscrewed by pressing the "STB-RESET" button.

1. Remove the protective cap 1
2. Press the reset button 2.
3. Replace the protective cap.

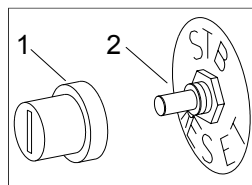

### Burner

If the flame burns unevenly or goes out, the unit is switched off by the burner. The malfunction light of the burner lights up.

1. Release the burner by pressing the reset button.
2. Please note that the burner can only be reset after waiting 60 seconds.

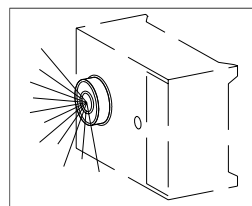

 **Before resetting the unit, check the operating conditions to ensure that the STB temperature is not exceeded again.**

## Maintenance

Depending on the operating conditions, the units must be serviced as necessary, at least once every two years by a authorised individual to ensure that they are functioning properly

The test results must be recorded in a test log which is kept in a safe place until the next test so that it can be provided to authorised persons for control purposes at any time..

The people responsible for operating the unit must inspect the unit prior to beginning work for visible defects of the operating and safety mechanisms as well as to ensure that the protective mechanisms are there and working properly. If defects are found, the supervisor must be notified.

If defects are found that jeopardize the operational safety of the unit, the operation of the affected components must be suspended immediately!

Regular maintenance and care, especially after each heating period, are required to ensure a long service life and a faultless operation of the unit.

 **When the unit is being serviced, adjusted or repaired, the gas supply has to be turned off and the unit unplugged from the power supply!**

Please observe the following:

The unit must be maintained and cleaned at regular intervals.

The unit must be kept free of dust and other deposits and may only be cleaned using a dry or damp cloth. *Do not use place the unit in a direct stream of water.*

Do not use any aggressive cleaning agents or those which are harmful to the environment.

Do not use cleaning agents which contain solvents.

Use only suitable cleaners even when the unit is extremely dirty.

Check air suction and blow-out grille on a regular basis and clean when necessary.

Make sure that the air intake for combustion air, the injector behind it and the gas nozzle are not dirty.

Check gas burner, gas nozzle and gasket for damage; replace when necessary.

Clean baffle plate regularly.

 **Bright yellow flames are an indication that the fresh air supply is insufficient or that there is dirt inside the unit.**

### Removal and Cleaning of the Burner

1. Shut off the gas supply and unplug the unit from the power supply.
2. Remove the blow-out grille, the outside casing and the inspection cover.



3. Loosen the clamping screw on the nozzle holder.
4. Loosen the clamping screw on the electrode holder.
5. Pull the ignition and ionisation electrodes out of the electrode holder.
6. Remove the burner fastening screws and pull the burner out of the unit.
7. Clean the burner using a steel brush and compressed air.
8. Put the burner back into the unit and mount the ignition and ionisation electrodes in the electrode holder.
9. Adjust the ignition electrode in accordance with the specifications below and tighten the fastening screw on the electrode holder.  
*The tip of the ionisation electrode must be located in the area of the flame.*

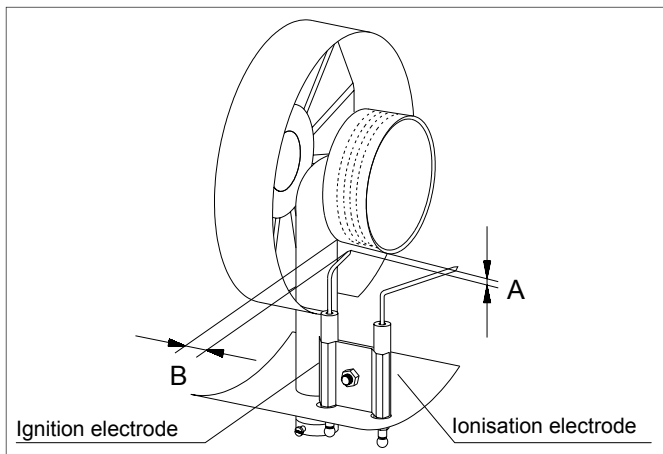

Unit	A	B
PGT 30 / 30 E	3 mm	15 mm
PGT 60 / 60 E	3 mm	15 mm
PGT 100 / 100 E	4 mm	30 mm

approx. dimensions

Adjustment instructions:

Dimension A = Distance from the tip of the ignition electrode to the bottom of the burner.

Dimension B = Distance from the tip of the ignition electrode to the back edge of the burner.

10. Assemble all other parts in the reverse order.
11. Test the entire unit to ensure that it is functioning properly; make sure that all gas supply hoses are impermeable using either a soap solution or a leak detection spray.
12. Conduct an electrical safety test after performing any maintenance work.

 **Adjustments or maintenance work may only be performed by authorised personnel!**

## Service and Guarantee

For the guarantee to be valid, the customer must completely fill out the "guarantee certificate" enclosed with all heating units and send it back to REMKO GmbH & Co. KG in a timely manner after purchasing of the unit and putting it into operation.

The units have undergone testing at the factory to ensure proper functioning. If there are still malfunctions that cannot be fixed by the operator using the troubleshooting instructions, please contact your dealer or contract partner.

**An operation/use other than indicated in these instructions is prohibited!**  
 **In the case of non-compliance, we assume no liability and our guarantee becomes null and void.**

### Proper Use

These devices have been designed and equipped exclusively to be used for heating and ventilation for industrial and commercial purposes.

The manufacturer is not liable for any damage resulting from non-adherence to manufacturer specifications, legal requirements or any modifications to the units.

# Wiring Diagram

## PGT 30 / 30 E und 60 / 60 E

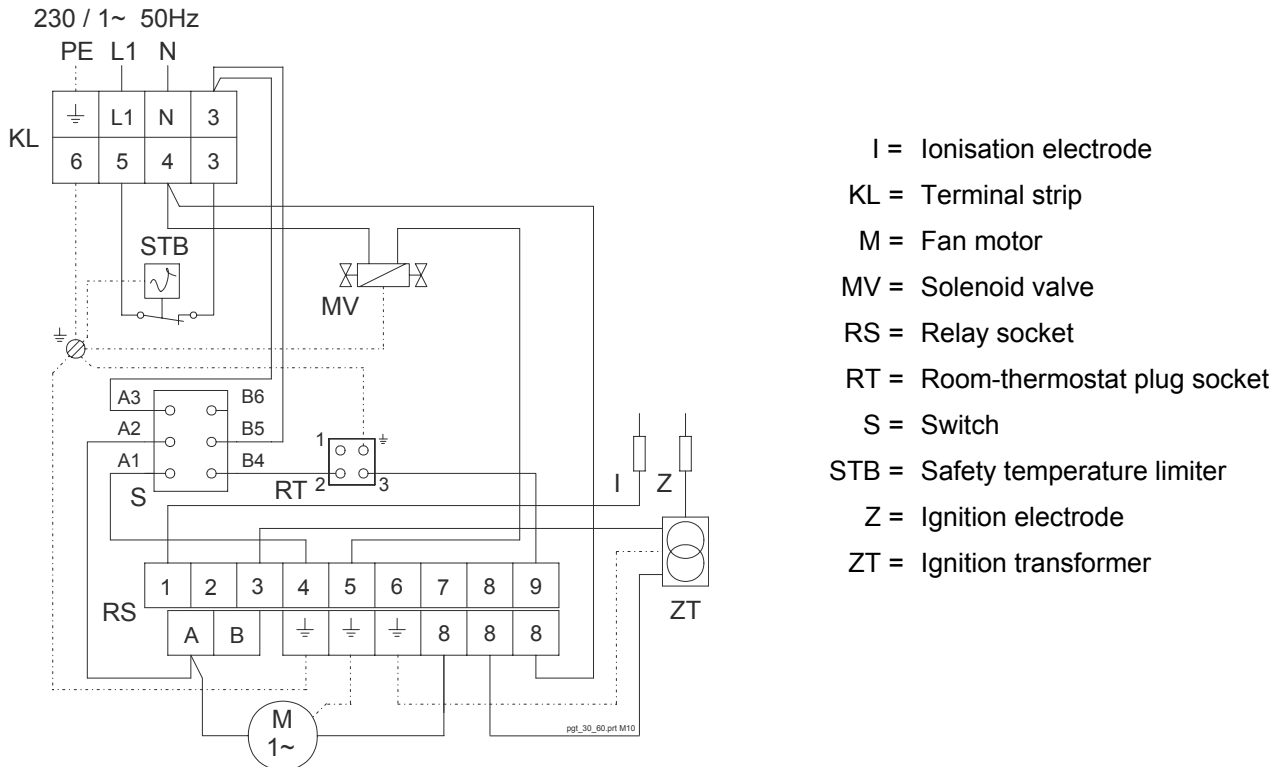

## PGT 100 / 100 E

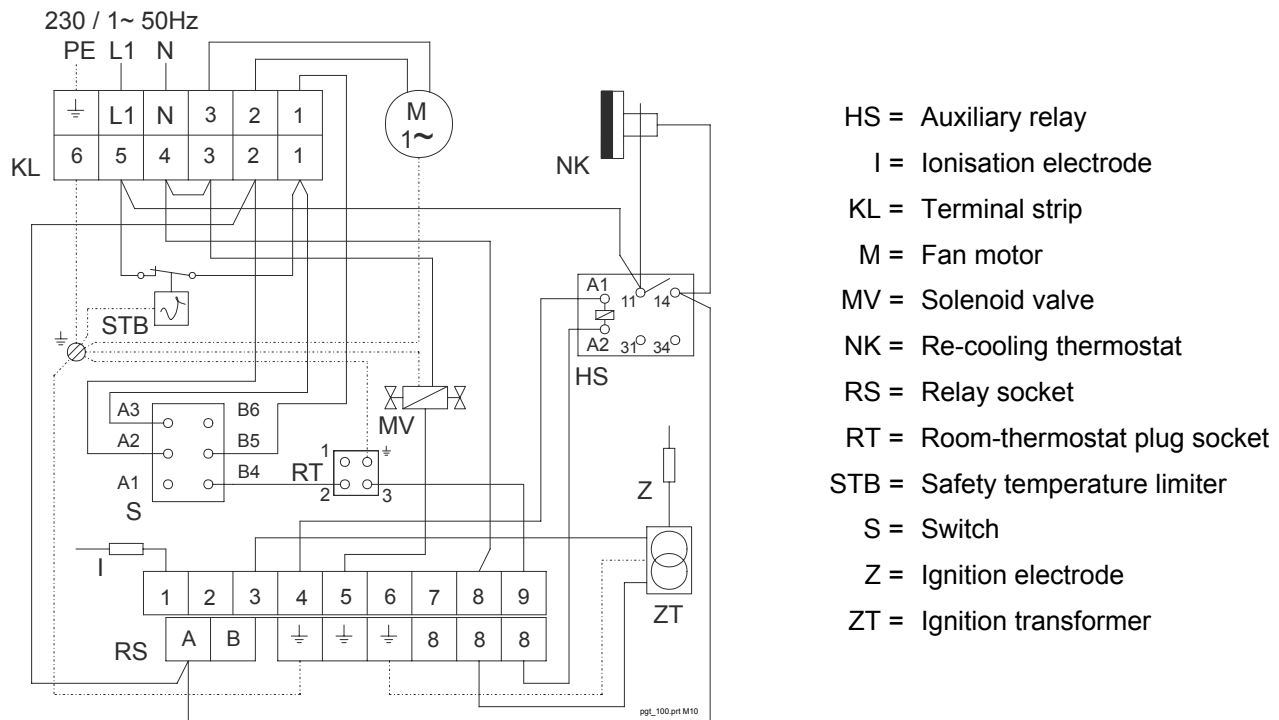

We reserve the right to make changes to dimensions and design in the interest of technical progress.

# Technical Data

Series		PGT 30 / 30 E	PGT 60 / 60 E	PGT 100 / 100 E
Rated heat output	kW	26	55	100
Heating capacity	kW	10– 26	25– 55	50– 100
Air output	m <sup>3</sup> /h	800	1.450	3.600
Fuel/type of gas		Liquid gas Cat. I <sub>3</sub> B/P, I <sub>3</sub> +		
Gas pressure	bar	1.5	1.5	1.5
Gas consumption	kg/h	0.78– 2.0	1.95– 4.27	3.9– 7.8
Electrical connection 1~	V	230	230	230
Frequency	Hz	50	50	50
Power consumption max.	kW	0.07	0.11	0.125
Fuse protection	A	10	10	10
Type of protection		IP 44	IP 44	IP 44
Sound pressure level L <sub>pA</sub> 1m <sup>1)</sup>	dB(A)	56– 69	62– 72	74– 82
Weight (without accessories)	kg	12	20	47
Dimensions total	length	mm	450	650
	width	mm	260	320
	height	mm	410	510

1) noise measuring DIN 45635 - 01- KL 3

## Technical Data Of The Burner Relay

Operating current	230 V (-15 % + 10 %)
Frequency	50 Hz (40 - 60 Hz)
Safety period	5 seconds
Time to wait after unit switches off due to malfunction	ca. 60 seconds
Permissible ambient temperature	- 20° C ... + 60 °C
Min. required ionisation current	5 µA
Sensitivity (ionisation current)	1 µA
Type of protection	IP 44

We reserve the right to make changes to dimensions and design in the interest of technical progress.

# Exploded View PGT 30 / 30 E

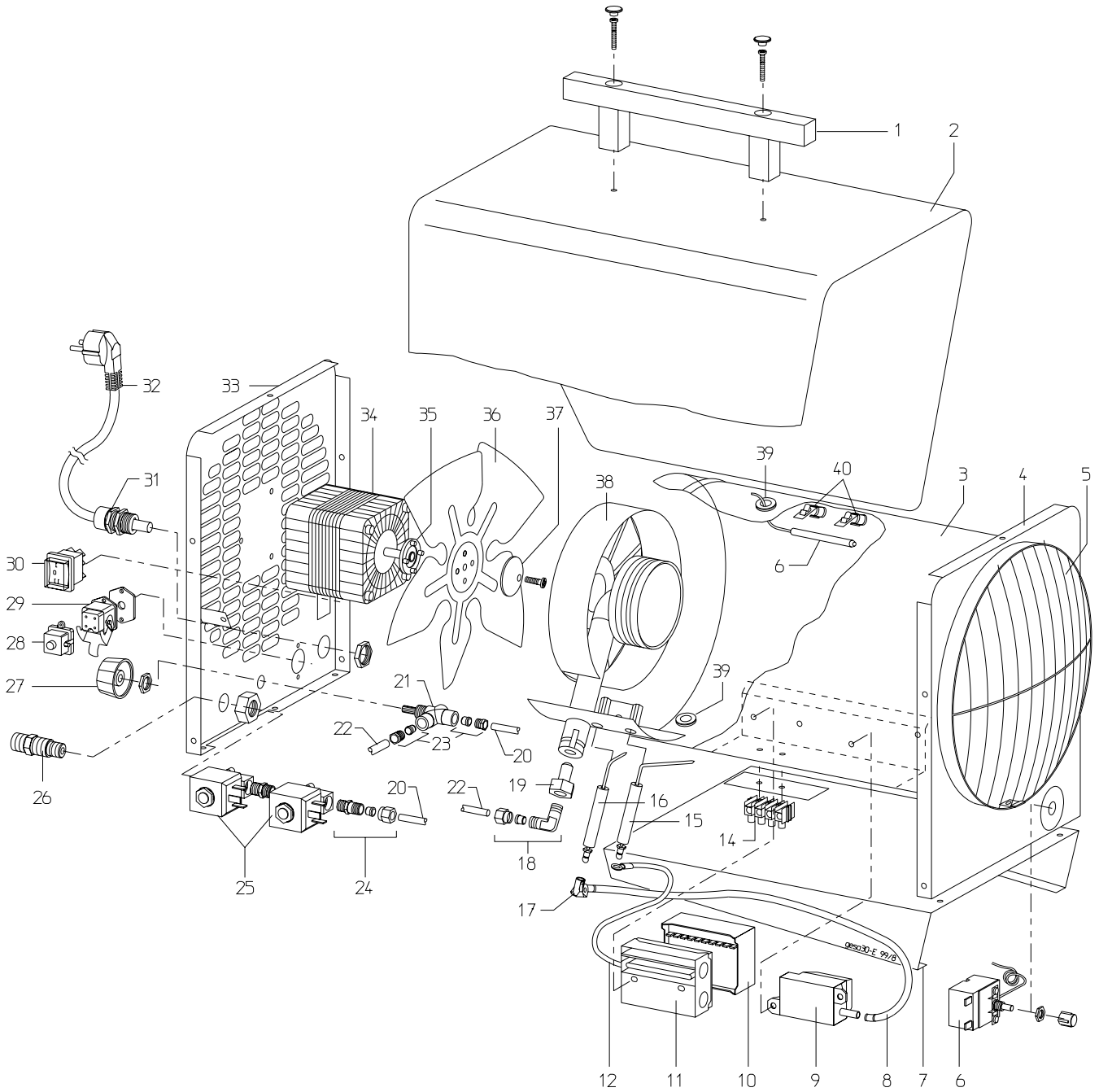

We reserve the right to make changes to dimensions and design in the interest of technical progress.

## Spare Part List PGT 30 / 30 E

No.	Description	Ref. No.
1	transport handle	1101142
2	outside casing PGT 30	1101440
2a	outside casing PGT 30 E (stainless steel)	1101463
3	combustion chamber	1101384
4	end plate, front	1101479
5	blow-out protection grille	1101383
6	safety temperature limiter with sensor	1101197
7	inspection cover	1101385
8	ignition cable	1101521
9	ignition transformer	1101520
10	socket for burner relay	1102534
11	burner relay	1101526
12	cable for ionisation	1101187
14	terminal strip, 4-lines	1101442
15	ignition electrode	1101186
16	ignition electrode	1101180
17	connection clip	1101181
18	angled couple 1/8"x6 mm	1101316
19	gas nozzle	1101159
20	gas supply pipe M/R	1101444
21	gas regulator	1101411
22	gas supply pipe R/D	1101453
23	screw attachment M10x1	1101409
24	GE-screw attachment 1/4"x6	1101396
25	solenoid valve	1101376
26	connection fitting 3/8", left	1101134
27	adjustment knob	1101192
28	shunt plug	1101019
29	thermostat plug socket	1101018
30	switch	1101188
31	strain relief	1101267
32	connection cable incl. plug	1101320
33	end plate, at the back	1101480
34	fan motor	1108049
35	clutch plate B 6 Ø	1108455
36	fan wing	1101392
37	clutch disc	1101375
38	gas burner	1101417
39	protection cover	1101304
40	retaining bracket	1101395
not shown	re-cooling relay (accessories)	1105075
	pressure controller with protection from hose breakage	1101470
	2 metres of continuous gas hose	1101419
	2 metres of continuous gas hose (HD for building sites)	1101174
	5 metres of continuous gas hose (HD for building sites)	1108410
	10 metres of continuous gas hose (HD for building sites)	1108411
	multi-cylinder set (2 - 3 cylinders)	1014050
	T - connection for multi-cylinder set	1101177
	nylon seal for T - connection	1101178
	HD - gas hose 0.4m for multi-cylinder set	1101179
	thermostat-plug	1101020

**When ordering spare parts, please indicate ref. no. and machine no. (see type plate)!**

# Exploded View PGT 60 / 60 E

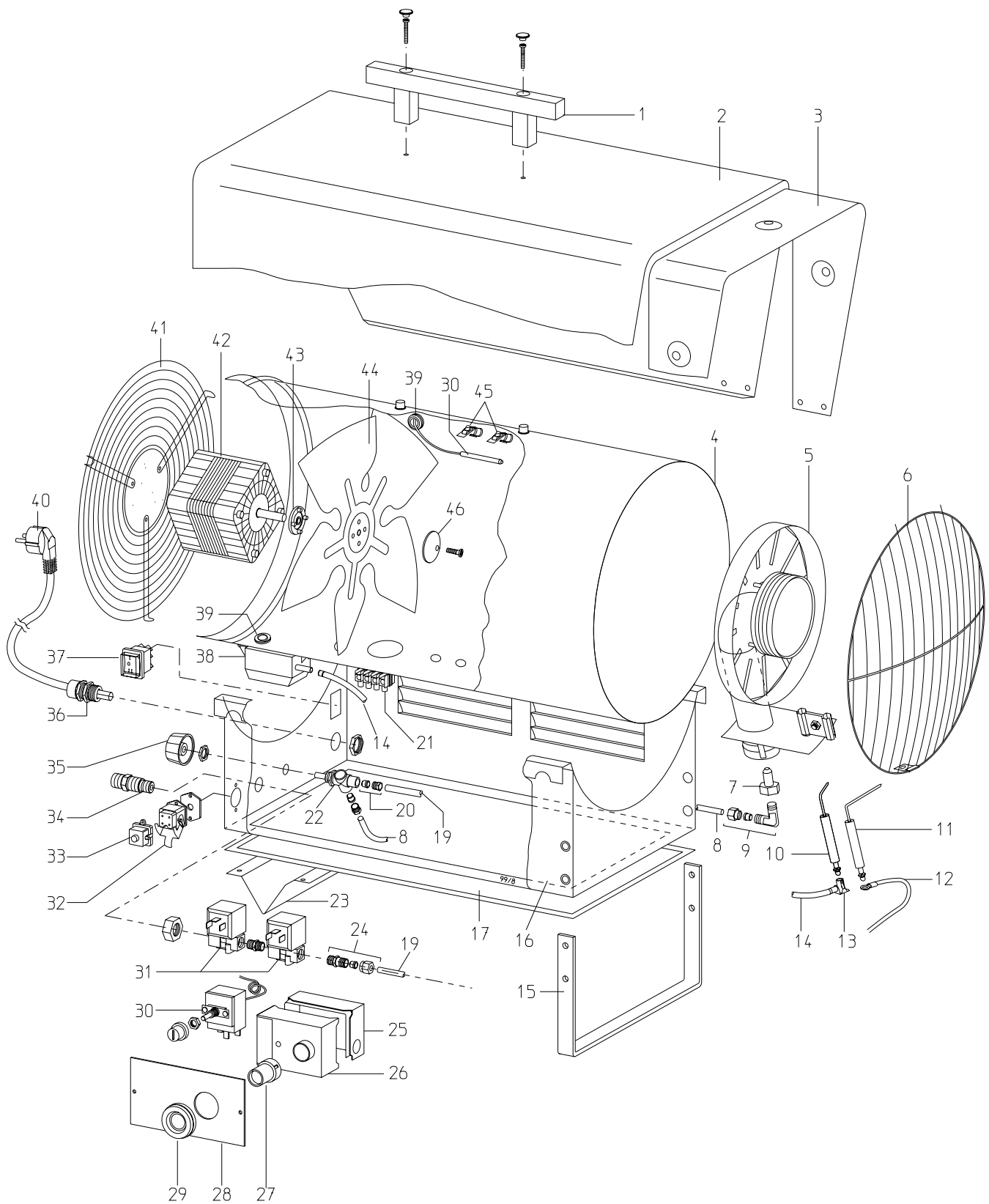

We reserve the right to make changes to dimensions and design in the interest of technical progress.

# Spare Part List PGT 60 / 60 E

No.	Description	Ref. No.
1	transport handle	1101142
2	outside casing PGT 60	1101420
2a	outside casing PGT 60 E (stainless steel)	1101461
3	insulation	1101421
4	combustion chamber	1101422
5	gas burner	1101423
6	blow-out protection grille	1101424
7	gas nozzle	1101426
8	gas supply pipe R/D	1101457
9	angled screw coupling 1/8" x 6mm	1101316
10	ignition electrode	1101280
11	ionisation electrode	1101186
12	cable for ionisation	1101187
13	connection clip	1101181
14	ignition cable	1101521
15	support bracket, front	1101427
16	base plate	1101428
17	inspection cover	1101469
19	gas supply pipe M/R	1101441
20	screw attachment M10x1	1101409
21	terminal strip, 4-lines	1101442
22	gas regulator	1101412
23	support, rear	1101249
24	GE-screw attachment 1/4" x 6mm	1101396
25	socket for burner relay	1102534
26	burner relay	1101526
27	button extension	1101524
28	cover plate	1101525
29	seal for cover plate	1101528
30	safety temperature limiter incl. sensor	1101197
31	solenoid valve	1101376
32	thermostat plug socket	1101018
33	shunt plug	1101019
34	gas connection nipple 3/8" lks.	1101134
35	adjustment knob	1101192
36	strain relief	1101267
37	switch	1101188
38	ignition transformer	1101520
39	protection cover	1101304
40	connection cable incl. plug	1101320
41	air inlet grille	1101432
42	fan motor	1101254
43	clutch plate B 8 Ø	1101255
44	fan wing	1101150
45	retaining bracket	1101395
46	clutch disc	1101375
not shown	re-cooling relay (accessories)	1105075
	pressure controller with protection from hose breakage	1101470
	2 metres of continuous gas hose	1101419
	2 metres of continuous gas hose (HD for building sites)	1101174
	5 metres of continuous gas hose (HD for building sites)	1108410
	10 metres of continuous gas hose (HD for building sites)	1108411
	multi-cylinder set (2 - 3 cylinders)	1014050
	T - connection for multi-cylinder set	1101177
	nylon seal for T - connection	1101178
	HD - gas hose 0.4m for multi-cylinder set	1101179
	thermostat plug	1101020

**When ordering spare parts, please indicate ref. no. and machine no. (see type plate)!**

# Exploded View PGT 100 / 100 E

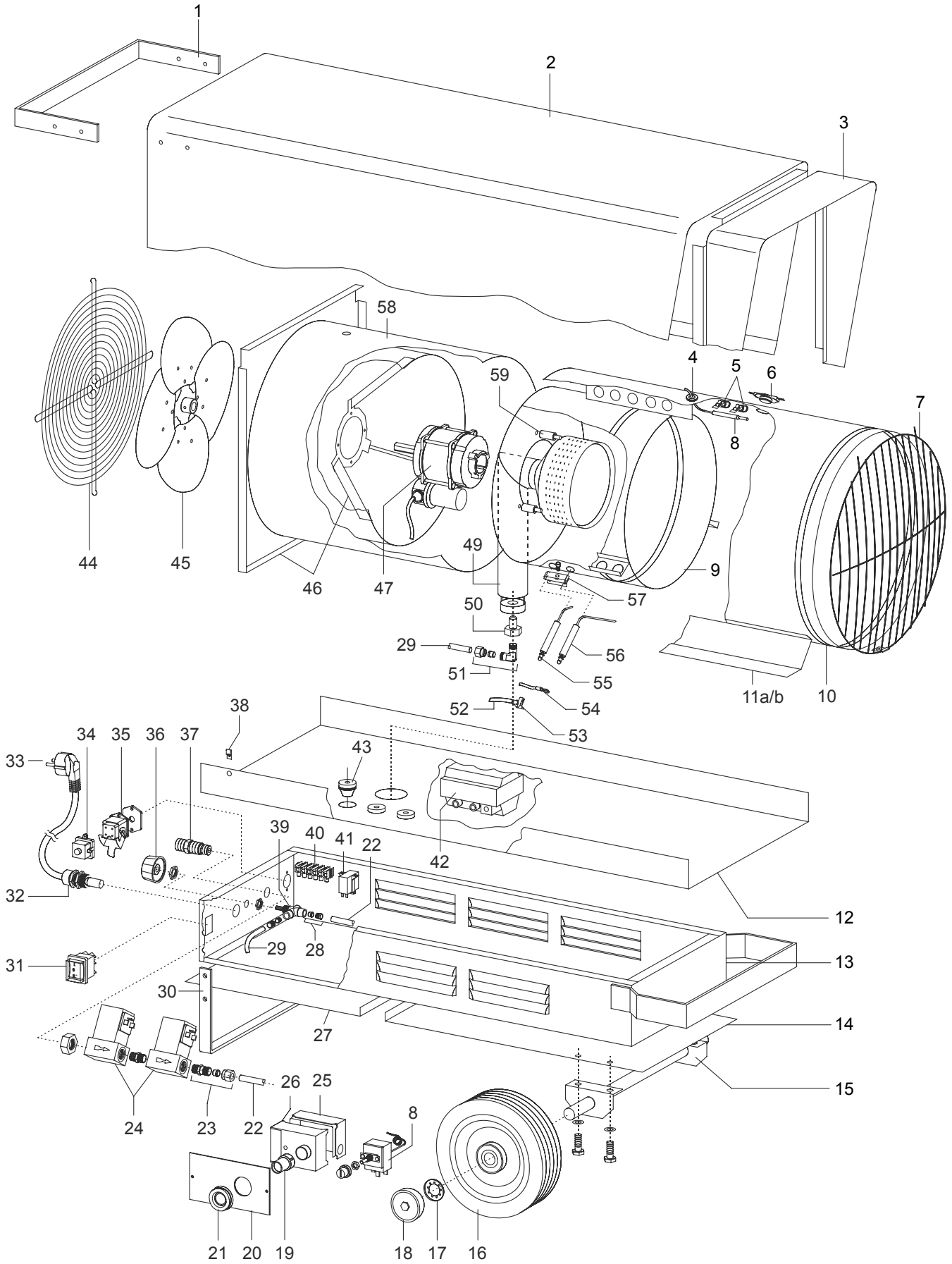

We reserve the right to make changes to dimensions and design in the interest of technical progress.



# Spare Part List PGT 100 / 100 E

No.	Description	Ref. No.	No.	Description	Ref. No.
1	transport handle	1101680	29	gas supply pipe R/D	1101690
2	outside casing PGT 100	1101681	30	support, rear	1101691
2	outside casing PGT 100 E (st. steel)	1101462	31	switch	1101188
3	insulation	1101682	32	strain relief	1101267
4	protection cover	1101304	33	connection cable incl. plug	1101320
5	retaining bracket	1101395	34	shunt plug	1101019
6	re-cooling thermostat	1101683	35	thermostat plug socket	1101018
7	blow-out protection grille	1101684	36	adjustment knob, cpl.	1101192
8	safety temperature limiter incl. sensor	1101197	37	gas connection fitting 3/8", left	1101134
9	combustion chamber	1101685	38	mounting clip	1102906
10	inside housing, front	1101686	39	gas regulator	1101692
11a	housing holder, right	1101631	40	terminal strip, 6-lines	1101366
11b	housing holder, left	1101632	41	auxiliary relay	1108038
12	assembly plate	1101687	42	ignition transformer	1101666
13	unit base	1101688	43	protection cover, large	1101677
14	base plate	1101652	44	air inlet incl. grille	1101648
15	axle	1101653	45	fan wing	1101693
16	wheel	1102155	46	fan housing incl. motor mount	1101694
17	retaining ring	1101622	47	fan motor	1101634
18	wheel cap	1101623	49	gas burner	1101695
19	button extension	1101524	50	gas nozzle	1101659
20	cover plate	1101525	51	angled couple 1/8" x 6mm	1101316
21	seal for cover plate	1101528	52	ignition cable	1101696
22	gas supply pipe M/R	1101441	53	connection clip	1101181
23	GE-screw attachment 1/4" x 6mm	1101396	54	cable for ionisation	1101187
24	solenoid valve	1101165	55	ignition electrode	1101698
25	socket for burner relay	1102534	56	ionisation electrode	1101697
26	burner relay	1101526	57	electrode fitting	1101633
27	inspection cover	1101651	58	inside housing, rear	1101450
28	screw attachment M10 x 1	1101409	59	spacing sleeve	1101699



not shown

pressure regulator	1101418
hose breakage protection (SBS)	1101664
2 metres of continuous gas hose	1101419
2 metres of continuous gas hose (HD for building sites)	1101174
5 metres of continuous gas hose (HD for building sites)	1108410
10 metres of continuous gas hose (HD for building sites)	1108411
multi-cylinder set (2 - 3 cylinders)	1014050
T - connection for multi-cylinder set	1101177
nylon seal for T - connection	1101178
HD - gas hose 0.4m for multi-cylinder set	1101179
thermostat-plug	1101020

**When ordering spare parts, please indicate ref. no. and machine no. (see type plate)!**

# Troubleshooting

Problem:	Cause
- Unit doesn't start	1 – 2 – 3 – 4 – 5 – 7 – 10 – 13 – 17 – 18
- Unit stops during operation	2 – 6 – 7 – 8 – 9 – 10 – 13 – 14 – 17
- Fan blows but gas supply is blocked or the flame does not ignite	7 – 12 – 13 – 14
- Gas supply is blocked or the flame goes out	6 – 7 – 8 – 9 – 10 – 13 – 14 – 17 – 18
- Fuel consumption is too high	13
- Unit can't be shut down	5 – 15
- Heating capacity diminishes during continuous operation	14
- Heating capacity cannot be regulated	11

 **Shut off the gas supply and unplug the unit from the power supply before performing any work on the unit!**  
**Adjustments or maintenance work may only be performed by authorised personnel!** 

Cause:	Remedy:
1. No electrical connection	- Plug the unit into an appropriate mains socket (230V/1~ 50Hz))
2. Fan motor is overloaded (fan blows irregularly or is blocked)	- Check fan motor, fan blade and clutch plate and replace if necessary
3. The room thermostat is set to low	- Setting must be higher than the existing room temperature
4. No bridge plug in the room thermostat socket	- Connect the bridge plug to the thermostat socket
5. The operating switch is defective	- Close gas supply, pull plug from the power socket and replace operating switch
6. The polarity of the unit plug is not correct.	- Turn around the unit plug by 180° (check polarity)
7. No gas pressure on solenoid valve	- Check gas supply - Check contents of gas cylinders - Check gas hose(s) for damage
8. The ionisation or ignition electrodes are not set properly	- Set it. specifications; check porcelain insulation of the electrodes
9. Air suction grille is dirty	- Clean air suction grille
10. Unit switched off by the safety temperature limiter (STB). The power plug (PGT 100 only) was separated from the power supply before the fans stopped running	- Inspect air intake and outlet protection grilles (clean if necessary) - Ensure that the fresh air supply is adequate - Release STB (STB - Reset)
11. The gas regulation is defective or dirty	- Replace or clean gas regulation
12. The ignition does not work	- Set operating switch to "I" (heating mode) - Check ignition cable for damage - Check electrode setting, check cycle ignition
13. Pressure controller defective or improper pressure controller attached or hose breakage protection is blocked	- Attach original pressure controller - Release hose breakage protection or replace it
14. Ice has formed on the gas cylinder(s) due to low temperatures and too much gas output	- Replace empty gas cylinder(s) and connect 2-3 cylinders using multi cylinder set (Ref-No. 1014050)
15. Solenoid valve does not open	- Shut off gas supply - Let flame burn out - Set operating switch to "0" and unplug the unit - Replace solenoid valve
16. Gas hose(s) are leaking	- Find leakage using foam substance to eliminate leaks
17. The malfunction light in the burner is lit up	- Release burner by pressing the malfunction button
18. The burner is defective	- Replace defective burner

# Maintenance Log

**Model:** : ..... **Model No.:** : .....

	1	2	3	4	5	6	7	8	9	10	11	12	13	14	15	16	17	18	19	20
Clean unit -surface-																				
Clean unit -interior-																				
Clean fan blade																				
Clean combustion chamber																				
Clean gas burner																				
Set/replace ignition electrode																				
Check gas hose																				
Check gas supply parts for leaks																				
Check safety facility																				
Check protection guards																				
Check unit for damage																				
Check fastening screws																				
Electrical safety inspections																				
Test run																				

Remarks:.....  
 .....

1. Date:..... ..... Signature	2. Date: ..... ..... Signature	3. Date: ..... ..... Signature	4. Date: ..... ..... Signature	5. Date:..... ..... Signature
6. Date:..... ..... Signature	7. Date: ..... ..... Signature	8. Date: ..... ..... Signature	9. Date: ..... ..... Signature	10. Date:..... ..... Signature
11. Date:..... ..... Signature	12. Date: ..... ..... Signature	13. Date: ..... ..... Signature	14. Date: ..... ..... Signature	15. Date:..... ..... Signature
16. Date:..... ..... Signature	17. Date: ..... ..... Signature	18. Date: ..... ..... Signature	19. Date: ..... ..... Signature	20. Date:..... ..... Signature

**Adjustments or maintenance work may only be performed by authorised personnel!**

**REMKO GmbH & Co. KG**

Klima- und Wärmetechnik

32791 Lage, Im Seelenkamp 12

32777 Lage, PO Box 1827

Phone +49 5232 606-0

Fax +49 5232 606-260

E-mail [info@remko.de](mailto:info@remko.de)

Internet [www.remko.de](http://www.remko.de)