



An Oshkosh Corporation Company

Service and Maintenance Manual

Model

E400A/AJP

E400A/AJPnarrow

M400A/AJP

M400A/AJPnarrow

P/N - 3121827

March 20, 2014



An Oshkosh Corporation Company

SECTION A. INTRODUCTION - MAINTENANCE SAFETY PRECAUTIONS

A GENERAL

This section contains the general safety precautions which must be observed during maintenance of the aerial platform. It is of utmost importance that maintenance personnel pay strict attention to these warnings and precautions to avoid possible injury to themselves or others, or damage to the equipment. A maintenance program must be followed to ensure that the machine is safe to operate.

⚠ WARNING

MODIFICATION OR ALTERATION OF AN AERIAL WORK PLATFORM SHALL BE MADE ONLY WITH WRITTEN PERMISSION FROM THE MANUFACTURER.

The specific precautions to be observed during maintenance are inserted at the appropriate point in the manual. These precautions are, for the most part, those that apply when servicing hydraulic and larger machine component parts.

Your safety, and that of others, is the first consideration when engaging in the maintenance of equipment. Always be conscious of weight. Never attempt to move heavy parts without the aid of a mechanical device. Do not allow heavy objects to rest in an unstable position. When raising a portion of the equipment, ensure that adequate support is provided.

⚠ WARNING

SINCE THE MACHINE MANUFACTURER HAS NO DIRECT CONTROL OVER THE FIELD INSPECTION AND MAINTENANCE, SAFETY IN THIS AREA RESPONSIBILITY OF THE OWNER/OPERATOR.

B HYDRAULIC SYSTEM SAFETY

It should be noted that the machines hydraulic systems operate at extremely high potentially dangerous pressures. Every effort should be made to relieve any system pressure prior to disconnecting or removing any portion of the system.

C MAINTENANCE

⚠ WARNING

FAILURE TO COMPLY WITH SAFETY PRECAUTIONS LISTED IN THIS SECTION COULD RESULT IN MACHINE DAMAGE, PERSONNEL INJURY OR DEATH AND IS A SAFETY VIOLATION.

- ENSURE REPLACEMENT PARTS OR COMPONENTS ARE IDENTICAL OR EQUIVALENT TO ORIGINAL PARTS OR COMPONENTS.
- NO SMOKING IS MANDATORY. NEVER REFUEL DURING ELECTRICAL STORMS. ENSURE THAT FUEL CAP IS CLOSED AND SECURE AT ALL OTHER TIMES.
- REMOVE ALL RINGS, WATCHES AND JEWELRY WHEN PERFORMING ANY MAINTENANCE.
- DO NOT WEAR LONG HAIR UNRESTRAINED, OR LOOSE-FITTING CLOTHING AND NECKTIES WHICH ARE APT TO BECOME CAUGHT ON OR ENTANGLED IN EQUIPMENT.
- OBSERVE AND OBEY ALL WARNINGS AND CAUTIONS ON MACHINE AND IN SERVICEMANUAL.
- KEEP OIL, GREASE, WATER, ETC. WIPED FROM STANDING SURFACES AND HAND HOLDS.
- USE CAUTION WHEN CHECKING A HOT, PRESSURIZED COOLANT SYSTEM.
- NEVER WORK UNDER AN ELEVATED BOOM UNTIL BOOM HAS BEEN SAFELY RESTRAINED FROM ANY MOVEMENT BY BLOCKING OR OVERHEAD SLING, OR BOOM SAFETY PROP HAS BEEN ENGAGED.
- BEFORE MAKING ADJUSTMENTS, LUBRICATING OR PERFORMING ANY OTHER MAINTENANCE, SHUT OFF ALL POWER CONTROLS.
- BATTERY SHOULD ALWAYS BE DISCONNECTED DURING REPLACEMENT OF ELECTRICAL COMPONENTS.
- KEEP ALL SUPPORT EQUIPMENT AND ATTACHMENTS STOWED IN THEIR PROPER PLACE.
- USE ONLY APPROVED, NONFLAMMABLE CLEANING SOLVENTS.

REVISION LOG

Original Issue	- August 15, 2000
Revised	- October 1, 2001
Revised	- December 18, 2001
Revised	- April 11, 2002
Revised	- May 24, 2004
Revised	- September 17, 2007
Revised	- January 21, 2008
Revised	- January 27, 2009
Revised	- January 7, 2013
Revised	- April 26, 2013
Revised	- October 24, 2013
Revised	- March 20, 2014

SECTION NO.	TITLE	PAGE NO.
SECTION A - INTRODUCTION - MAINTENANCE SAFETY PRECAUTIONS		
A	General	A-1
B	Hydraulic System Safety	A-1
C	Maintenance	A-1
SECTION 1 - SPECIFICATIONS		
1.1	Operating specifications	1-1
1.2	Capacities	1-1
1.3	Battery Charger	1-1
1.4	Drive System	1-1
1.5	Hydraulic Pump/Electric Motor Assembly	1-1
1.6	Generator	1-1
1.7	Tires	1-1
1.8	Dimensional Data	1-2
1.9	Function Speeds	1-2
	Machine Orientation When Doing Function Tests	1-3
1.10	Torque Specifications	1-3
1.11	Cylinder Specifications	1-4
1.12	Major Component Weights	1-4
1.13	Critical Stability Weights	1-5
1.14	Pressure Settings	1-5
1.15	Serial Number Locations	1-6
1.16	Lubrication	1-6
	Lubrication Specifications	1-6
1.17	Operator Maintenance & Lubrication	1-8
SECTION 2 - GENERAL		
2.1	Machine Preparation, Inspection, and Maintenance	2-1
	General	2-1
	Preparation, Inspection, and Maintenance	2-1
	Pre-Start Inspection	2-1
	Pre-Delivery Inspection and Frequent Inspection	2-1
	Annual Machine Inspection	2-1
	Preventive Maintenance	2-1
2.2	Service and Guidelines	2-2
	General	2-2
	Safety and Workmanship	2-2
	Cleanliness	2-2
	Components Removal and Installation	2-2
	Component Disassembly and Reassembly	2-3
	Pressure-Fit Parts	2-3
	Bearings	2-3
	Gaskets	2-3
	Bolt Usage and Torque Application	2-3
	Hydraulic Lines and Electrical Wiring	2-3
	Hydraulic System	2-3
	Lubrication	2-3
	Battery	2-3
	Lubrication and Servicing	2-3
2.3	Lubrication and Information	2-3
	Hydraulic System	2-3
	Hydraulic Oil	2-4
	Changing Hydraulic Oil	2-4
	Lubrication Specifications	2-4

TABLE OF CONTENTS

SECTION NO.	TITLE	PAGE NO.
2.4	Cylinder Drift Test	2-4
	Platform Drift	2-4
	Cylinder Drift	2-4
2.5	Pins and Composite Bearing Repair Guidelines	2-5
2.6	Welding on JLG Equipment	2-5
	Do the Following When Welding on JLG Equipment	2-5
	Do NOT Do the Following When Welding on JLG Equipment	2-5
SECTION 3 - CHASSIS & TURNTABLE		
3.1	Tires & Wheels	3-1
	Tire Inflation	3-1
	Tire Damage	3-1
	Tire Replacement	3-1
	Wheel Replacement	3-1
	Wheel Installation	3-1
3.2	Spindle	3-2
	Setting Wheel Bearing End Play	3-2
	Specifications	3-2
	Checking	3-2
	Greasing Requirements	3-2
3.3	Drive Hub (Part No. 2780236)	3-4
	Disassembling	3-4
	Disassembly	3-5
	Disassembly of the first stage planetary assembly (7)	3-5
	Disassembly of second stage planet gears (1)	3-5
	Assembly of first stage planetary assembly (7)	3-5
	Assembly of end cover unit (8)	3-5
	Final Assembly	3-6
	Initial Start-up And After Repairs	3-6
	Maintenance	3-6
	Oil Change Interval-Gear Drive	3-6
	Setting of Tapered Roller Bearings	3-6
	Securing of the Shaft Nut	3-6
3.4	Drive Brake - Mico	3-8
	Disassembly	3-8
	Assembly	3-8
	Bleeding	3-8
3.5	Speed Sensor Adjustment	3-11
	Adjustment Procedure	3-11
	Speed Sensor Installation Verification	3-16
	Verification w/ Analyzer Procedure	3-16
3.6	Positrac/Tilt module	3-19
3.7	Swing Motor - S/N 0300135649 to Present	3-21
	Preparation Before Disassembly	3-24
	Disassembly and Inspection	3-24
	Assembly	3-30
	One Piece Stator Construction	3-37
	Two Piece Stator Construction	3-38
	Final Checks	3-38

SECTION NO.	TITLE	PAGE NO.
3.8	Swing Bearing	3-39
	Turntable Bearing Mounting Bolt Condition Check	3-39
	Wear Tolerance	3-40
	Replacement of Swing Bearing	3-41
	Swing Bearing Torque Value	3-43
	Checking Worm Gear End Play	3-43
	Adjusting End Play	3-43
3.9	Battery Maintenance and Charging	3-45
	Battery Maintenance, Quarterly	3-45
	Charging Sequence of Remote LED Card	3-45
	Battery Charging (On Board Charger)	3-47
	Optional On Board Generator	3-47
3.10	Battery Charger (S/N 0300059350 to Present)	3-49
	Operating Instructions	3-49
	Maintenance Instructions	3-49
	Battery Charger Fault Codes	3-49
	Excessive Battery Watering Requirements or Strong Sulphur (Rotten Egg) Smell	3-52
	Checking/Changing the Battery Charger Algorithm	3-53
3.12	Generator (Prior to S/N 88539)	3-54
	Alternator	3-54
	Dynamo and Dynamo Voltage Regulator	3-54
	Dynamo Output Fuse	3-54
	Control Fuse	3-54
	Start Battery	3-54
	Engine Starter	3-54
	Start Control Relay	3-54
	Fuel Control Relay	3-54
	Fuel Solenoid	3-54
	Engine Oil Temperature Sensor	3-54
	Alternator Output Current Sensor	3-54
	Engine Speed Sensor	3-54
	Engine Low Oil Pressure Switch	3-54
	Timing Sequences	3-54
	To Connect the JLG Control System Analyzer to the Generator	3-57
	Alarms and Fault Flash Codes	3-57
	Output Current and Voltage Settings	3-59
	Priming the Fuel Line	3-60
3.13	Generator (S/N 88539 to Present)	3-61
	Engine	3-61
	Alternator	3-61
	Dynamo and Dynamo Voltage Regulator	3-61
	Dynamo Output Fuse	3-61
	Control Fuse	3-61
	Start Battery	3-63
	Engine Starter	3-63
	Start Control Relay	3-63
	Fuel Control Relay	3-64
	Glow Plug Control Relay	3-64
	Glow Plug	3-64
	Fuel Pump	3-65
	Fuel Solenoid	3-65
	Engine Low Oil Pressure Switch	3-65

TABLE OF CONTENTS

SECTION NO.	TITLE	PAGE NO.
	Engine Oil Temperature Sensor	3-65
	Alternator Output Current Sensor	3-66
	Engine Speed Sensor	3-66
	RBS Engine/Generator Controller	3-66
	Warnings and Safety Precautions	3-67
	System Controls	3-67
	System Status and Performance Monitoring	3-67
	System Settings	3-67
	RBS Start	3-68
	RBS shutdown	3-68
	RBS Alarms and Flash Codes	3-69
	Resetting the RBS Controller	3-69
	Maintenance Schedule	3-69
	Troubleshooting	3-70
	APU Engine Start Battery Boosting	3-71
3.14	Supplementary fuse for apu	3-72
	Tools And Material	3-72
	Procedure	3-72
SECTION 4 - BOOM & PLATFORM		
4.1	Boom Maintenance	4-1
	Removal	4-1
	Disassembly	4-1
	Inspection	4-2
	Assembly	4-2
	Installation	4-3
4.2	Upper (Main) Boom Lift Cylinder	4-4
	Removal	4-4
	Installation	4-4
4.3	Mid Boom Lift Cylinder	4-4
	Removal	4-4
	Installation	4-5
4.4	Lower Boom Lift Cylinder	4-5
	Removal	4-5
	Installation	4-5
4.5	Upper Boom Telescope Cylinder	4-6
	Removal	4-6
	Installation	4-6
4.6	Mid and Lower Lift Cylinder Bleeding Procedure	4-7
4.7	Wear Pads	4-7
4.8	Boom Synchronizing Procedure	4-8
4.9	Articulating Jib Boom	4-8
	Removal	4-8
	Disassembly	4-8
	Inspection	4-8
	Assembly	4-10
4.10	Footswitch Adjustment	4-10
4.11	Boom Limit Switches	4-10

SECTION NO.	TITLE	PAGE NO.
4.12	Helac Rotary actuator	4-12
	Theory Of Operation	4-12
	Tools Required for Assembly/Disassembly.	4-15
	Disassembly.	4-15
	Inspection	4-19
	Assembly	4-19
	Installing Counterbalance Valve	4-23
	Testing the Actuator.	4-23
	Installation and Bleeding	4-25
	Troubleshooting.	4-26
4.13	Powertrack Maintenance.	4-27
	Removing a Link	4-27
	Installing a New Link	4-30
	Replacing Fixed End Brackets	4-35
	Replacing Moving End Brackets	4-37
 SECTION 5 - HYDRAULICS		
5.1	Lubricating O-Rings in the Hydraulic System.	5-1
	Cup and Brush.	5-1
	Dip Method	5-2
	Spray Method	5-2
	Brush-on Method	5-2
5.2	Cylinders - Theory of Operation	5-3
	Double Acting Cylinder	5-3
5.3	Cylinder Checking Procedures	5-3
	Cylinder Without Counterbalance Valves	5-3
	Cylinders With Single Counterbalance Valve	5-3
	Cylinders With Dual Counterbalance Valve.	5-14
5.4	Cylinder Repair	5-14
	Disassembly.	5-14
	Cleaning and Inspection	5-15
	Assembly	5-16
5.5	Pressure Setting Procedures	5-20
	Main Relief	5-20
	Upper Lift Down Relief.	5-20
	Lower Lift Down Relief.	5-20
	Telescope Relief	5-20
	Platform Level Up Relief.	5-20
	Platform Level Down Relief	5-21
	Steer Relief.	5-21
	Jib Lift (Up and Down) Relief.	5-21
	Jib Swing Relief	5-21
	Releveling Valve Relief.	5-21

TABLE OF CONTENTS

SECTION NO.	TITLE	PAGE NO.
SECTION 6 - JLG CONTROL SYSTEM		
6.1	JLG Control System Analyzer Kit Instructions	6-1
	Introduction	6-1
	To Connect the JLG Control System Analyzer	6-2
	Using the Analyzer.	6-3
	Changing the Access Level of the Hand Held Analyzer	6-4
	Adjusting Parameters Using the Hand Held Analyzer	6-5
	Machine Setup.	6-5
	Machine Personality Settings	6-6
	Machine Configuration Programming Information	6-10
	Level Vehicle Description	6-11
	Help Descriptions and Fault Flash Codes.	6-11
	Analyzer Diagnostics Menu Structure	6-21
	System Self Test	6-22
SECTION 7 - BASIC TROUBLESHOOTING, ELECTRICAL INFORMATION, & SCHEMATICS		
7.1	General	7-1
7.2	Troubleshooting	7-1
7.3	Multimeter Basics	7-19
	Grounding	7-19
	Backprobing	7-19
	Min/Max	7-19
	Polarity	7-19
	Scale	7-19
	Voltage Measurement	7-19
	Resistance Measurement	7-20
	Continuity Measurement	7-20
	Current Measurement	7-21
7.4	Checking Switches	7-21
	Basic Check	7-21
	Limit Switches	7-21
	Automatic Switches	7-22
	Switch Wiring - Low Side, High Side.	7-22
7.5	Applying Silicone Dielectric Compound to Electrical Connections	7-22
7.6	AMP Connector	7-23
	Applying Silicone Dielectric Compound to AMP Connectors.	7-23
	Assembly	7-23
	Disassembly.	7-25
	Wedge Lock	7-25
	Service - Voltage Reading	7-25
7.7	Deutsch Connectors	7-27
	DT/DTP Series Assembly.	7-27
	DT/DTP Series Disassembly	7-27
	HD30/HDP20 Series Assembly	7-28
	HD30/HDP20 Series Disassembly.	7-28

FIGURE NO.	TITLE	PAGE NO.
1-1.	Serial Number Locations	1-6
1-2.	Operator Maintenance & Lubrication Diagram	1-7
1-3.	Torque Chart (SAE Fasteners - Sheet 1 of 7)	1-11
1-4.	Torque Chart (SAE Fasteners - Sheet 2 of 7)	1-12
1-5.	Torque Chart (SAE Fasteners - Sheet 3 of 7)	1-13
1-6.	Torque Chart (SAE Fasteners - Sheet 4 of 7)	1-14
1-7.	Torque Chart (METRIC Fasteners - Sheet 5 of 7)	1-15
1-8.	Torque Chart (METRIC Fasteners - Sheet 6 of 7)	1-16
1-9.	Torque Chart (METRIC Fasteners - Sheet 7 of 7)	1-17
2-1.	Engine Operating Temperature Specifications - Kubota	2-9
3-3.	Spindle Assembly	3-3
3-1.	Drive Hub - Cutaway	3-7
3-2.	Drive Brake	3-9
3-3.	Speed Sensor Orientation	3-12
3-4.	Frame Mounted Electrical Components - Sheet 1 of 2	3-13
3-5.	Frame Mounted Electrical Components - Sheet 2 of 2	3-14
3-6.	Voltage Checks	3-15
3-7.	Steering Components and Spindles	3-18
3-8.	Drive Components	3-19
3-9.	Tilt Sensor Location	3-20
3-10.	Swing Motor - Cutaway	3-21
3-11.	Swing Motor - Exploded View	3-23
3-12.	Swing Bearing Feeler Gauge Check	3-39
3-13.	Swing Bearing Tolerance Boom Placement	3-40
3-14.	Swing Bearing Tolerance Measuring Point	3-41
3-15.	Swing Bearing Torquing Sequence	3-42
3-16.	Swing Components	3-44
3-17.	Remote LED Card	3-45
3-18.	Battery Cable Connections	3-46
3-19.	Batteries and Battery Charger (Prior to S/N 0300059350)	3-47
3-20.	On Board Generator	3-48
3-21.	Battery Charger ((S/N 0300059350 to Present)	3-50
3-22.	Generator Components	3-55
3-23.	Generator System Analyzer Flow Chart	3-58
3-24.	Generator	3-62
4-1.	Location of Components - Boom Removal	4-1
4-2.	Upper Boom Lift Cylinder Removal	4-4
4-3.	Mid Boom Lift Cylinder Removal	4-4
4-4.	Lower Boom Lift Cylinder Removal	4-5
4-5.	Upper Telescope Cylinder Removal	4-6
4-6.	Wear Pad Thickness	4-7
4-7.	Location of Components - Articulating Jib Boom	4-8
4-8.	Jib/Platform Components and Attaching Hardware	4-9

LIST OF FIGURES

FIGURE NO.	TITLE	PAGE NO.
4-9.	Platform Support Torque Values	4-10
4-10.	Boom Limit Switches	4-11
4-11.	Rotary Actuator (Exploded View)	4-13
4-12.	Rotary Actuator (Cutaway View)	4-14
4-13.	Rotator Counterbalance Valve	4-24
5-1.	Jib Cylinder	5-4
5-2.	Level Cylinder - A Models	5-5
5-3.	Level Cylinder - AJ & AJP Models	5-6
5-4.	Lower Lift Cylinder	5-7
5-5.	Mid Lift Cylinder	5-8
5-6.	Upper Lift Cylinder	5-9
5-7.	Master Cylinder - A Models	5-10
5-8.	Master Cylinder - AJ Models	5-11
5-9.	Steer Cylinder	5-12
5-10.	Telescope Cylinder	5-13
5-11.	Cylinder Barrel Support	5-14
5-12.	Capscrew Removal	5-15
5-13.	Cylinder Rod Support	5-15
5-14.	Tapered Bushing Removal	5-15
5-15.	Gar-Max Bearing Installation	5-16
5-16.	Rod Seal Installation	5-16
5-17.	Wiper Seal Installation	5-17
5-18.	Installation of Head Seal Kit	5-17
5-19.	Piston Seal Kit Installation	5-17
5-20.	Tapered Bushing Installation	5-18
5-21.	Seating the Tapered Bearing	5-18
5-22.	Poly-Pak Piston Seal Installation	5-18
5-23.	Rod Assembly Installation	5-19
5-24.	Jib Valve Location	5-22
5-25.	Brake/Steer Valve Components	5-23
5-26.	HydraForce Cartridge Torque Value Chart	5-24
5-27.	Main Valve Components Prior to S/N 62642	5-25
5-28.	Main Valve Components S/N 62642 to Present	5-26
6-1.	Hand Held Analyzer	6-1
6-2.	Control Module Location	6-2
6-3.	Analyzer Flow Chart (Software Version 3.x) - Sheet 1 of 3	6-18
6-4.	Analyzer Flow Chart (Software Version 3.x) - Sheet 2 of 3	6-19
6-5.	Analyzer Flow Chart (Software Version 3.x) - Sheet 3 of 3	6-20
7-1.	Voltage Measurement (DC)	7-19
7-2.	Resistance Measurement	7-20
7-3.	Continuity Measurement	7-20
7-4.	Current Measurement (DC)	7-21
7-5.	Connector Assembly Figure 1	7-23
7-6.	AMP Connector	7-23
7-7.	Connector Assembly Figure 2	7-24
7-8.	Connector Assembly Figure 3	7-24
7-9.	Connector Assembly Figure 4	7-24

FIGURE NO.	TITLE	PAGE NO.
7-10.	Connector Disassembly	7-25
7-11.	Connector Installation	7-26
7-12.	DT/DTP Contact Installation	7-27
7-13.	DT/DTP Contact Removal	7-27
7-14.	HD/HDP Contact Installation	7-28
7-15.	HD/HDP Locking Contacts Into Position	7-28
7-16.	HD/HDP Contact Removal	7-28
7-17.	HD/HDP Unlocking Contacts	7-28
7-18.	Electrical Components Installation - Sheet 1	7-30
7-19.	Electrical Components Installation - Sheet 2	7-31
7-20.	Electrical Schematic - Sheet 1 of 4	7-32
7-21.	Electrical Schematic - Sheet 2 of 4	7-33
7-22.	Electrical Schematic - Sheet 3 of 4	7-34
7-23.	Electrical Schematic - Sheet 4 of 4	7-35
7-24.	Hydraulic Schematic - M400A/E400A - Sheet 1 of 2	7-36
7-25.	Hydraulic Schematic - M400A/E400A - Sheet 2 of 2	7-37
7-26.	Hydraulic Schematic - M400AJ/E400AJ - Sheet 1 of 2	7-38
7-27.	Hydraulic Schematic - M400AJ/E400AJ - Sheet 2 of 2	7-39
7-28.	Hydraulic Schematic - M400AJ/E400AJ - Sheet 1 of 2	7-40
7-29.	Hydraulic Schematic - M400AJP/E400AJP - Sheet 2 of 2	7-41
7-30.	Hydraulic Schematic Component List	7-42

LIST OF TABLES

TABLE NO.	TITLE	PAGE NO.
1-1	Operating Specifications	1-1
1-2	Capacities	1-1
1-3	Battery Charger	1-1
1-4	Drive System	1-1
1-5	Hydraulic Pump/Electric Motor Assembly	1-1
1-6	Generator.	1-1
1-7	Tire Data	1-1
1-8	Dimensional Data	1-2
1-9	Function Speeds	1-2
1-10	Torque Requirements	1-3
1-11	Cylinder Specifications	1-4
1-12	Major Component Weights	1-4
1-13	Critical Stability Weights	1-5
1-14	Pressure Settings - Prior to S/N 0300062642	1-5
1-15	Pressure Settings - S/N 0300062642 to Present	1-5
1-16	Hydraulic Oil	1-6
1-17	Mobil DTE 11M Specs.	1-6
1-18	Mobil EAL H Series Specs	1-6
1-19	Lubrication Specifications.	1-8
2-1	Inspection and Maintenance	2-2
2-2	Cylinder Drift	2-4
2-3	Inspection and Preventive Maintenance Schedule	2-6
3-1	Wheel Torque Chart	3-2
3-2	Drive Brake Diagnosis	3-10
3-3	Swing Motor Troubleshooting.	3-22
3-11	Battery Charger Fault Codes (Delta-Q).	3-49
3-4	Battery Algorithms.	3-53
3-5	RBS Prestart Sequence.	3-56
3-6	RBS Startup Sequence	3-56
3-7	RBS Shutdown Sequence.	3-56
3-8	Generator System Flash Codes	3-57
3-9	Controller Interface Pin Assignments	3-66
3-10	RBS Alarms and Flash Codes.	3-69
3-11	Troubleshooting	3-70
4-1	Wear Pad Thickness	4-7
4-1	Troubleshooting	4-26
5-1	Cylinder Head and Tapered Bushing Torque Specifications.	5-19
5-2	Cylinder Piston Nut Torque Specifications)	5-19
5-3	Holding Valve Torque Specifications	5-19
5-4	Pressure Settings - Prior to S/N 0300062642	5-22
5-5	Pressure Settings - S/N 0300062642 to Present	5-22
6-1	Personality Ranges/Defaults	6-7
6-2	Machine Setup Descriptions	6-10
6-3	JLG Control System Flash Codes.	6-11
6-4	Help Descriptions and Fault Flash Codes	6-12
6-5	DIAGNOSTICS - Menu Descriptions	6-21
6-6	System Test Descriptions	6-23
6-7	System Test Messages	6-24
6-8	Diagnostic Fault Codes.	6-28
7-1	Platform Assembly - Troubleshooting.	7-2
7-2	Boom Assembly - Troubleshooting	7-4
7-3	Turntable Assembly - Troubleshooting.	7-9
7-4	Chassis Assembly - Troubleshooting	7-10
7-5	Hydraulic System - Troubleshooting	7-15
7-6	Electrical System - Troubleshooting	7-17

SECTION 1. SPECIFICATIONS

1.1 OPERATING SPECIFICATIONS

Table 1-1. Operating Specifications

Maximum Work Load (Capacity) Unrestricted:	500 lb. (230 kg)
Maximum Travel Grade (Gradeability)	30%
Maximum Travel Grade (Side Slope)	5°
Machine Weight (GVW)	
E400Anarrow	13100 lbs. (5942 kg)
M400Anarrow	13300 lbs. (6033 kg)
E400AJP	13700 lbs. (6214 kg)
M400AJP	13930 lbs. (6318 kg)
E400AJNarrow	14900 lbs. (6759 kg)
M400AJNarrow	15130 lbs. (6862 kg)
System Voltage	48 volts
Battery Life per Charge	7 hours continuous
Battery Recharge Time	
Charger	17 hours from full discharge
Generator	6.2 hours

1.2 CAPACITIES

Table 1-2. Capacities

Generator Fuel Tank	4 Gallons (15.1 L)
Hydraulic Oil Tank	
E/M 400A, E/M 400Anarrow	4 gallons. (15.14 liters)
E/M400AJP, E/M400AJNarrow	5 Gallons (19 L)
Hydraulic System (Including Tank)	9 Gallons (34.1 L)
Torque Hub, Drive *	19 ounces (0.50 L)
*Torque hubs should be one half full of lubricant.	

1.3 BATTERY CHARGER

Table 1-3. Battery Charger

Input	110 VAC, 60 HZ
Output	48 VDC (25 Amps)
Batteries (8)	6 Volt, 370 Amp Hour (20 hour rate)

1.4 DRIVE SYSTEM

Table 1-4. Drive System

Drive Motor	48 VDC, 12.5 H.P. @ 3200 rpm. continuous, rotation - reversible
Drive Brake- spring-applied, hydraulically released	Drive Brake- spring-applied, hydraulically released

1.5 HYDRAULIC PUMP/ELECTRIC MOTOR ASSEMBLY

Table 1-5. Hydraulic Pump/Electric Motor Assembly

Motor	48 VDC, 2.14 H.P. @ 2700 rpm.
Pump	0.098 in. [3]/rev. (1.6 cm[3]/rev.).
Pump Output	2.96 gpm (11.2 lpm) @ 3400 psi (234 Bar).

1.6 GENERATOR

Table 1-6. Generator

Alternator Output	58 volts @ 45 Amps
RPM's under max. load	3100
Start Battery	12 volts
Engine Oil	10W30 (Refer to Engine Manual)
Dynamo	12 volt, 15 amp DC
Dynamo Output Fuse	20 amps DC
Control Fuse	15 amps DC

1.7 TIRES

Table 1-7. Tire Data

Size E/M400A, E/M400AJP	240/55 - 17.5 Pneu. non marking 240/55 - 17.5 Foam Filled 26 x 7 x 20 non marking 240/55 - 17.5 Pneu. 240/55 - Foam Filled
Size E/M400Anarrow, E/M400AJNarrow	25 x 7 x 12 - non marking 22 x 6 x 17.5 - non marking
Tire Pressure (pneumatic)	90 psi. (6.2 Bar)
Max. Tire Load	
E/M 400Anarrow	5160 lbs. (2343 kg)
E/M400AJP	6300 lbs. (2860 kg)
E/M400AJNarrow	7200 lbs. (3268 kg)
Ground Bearing Pressure	
E/M 400A	80 psi (5.6kg/cm ²)
E/M 400Anarrow	95 psi (6.6 kg/cm ²)
E/M400AJP	80 psi (5.6 kg/cm ²)
E/M400AJNarrow	185 psi (13.0 kg/cm ²)

SECTION 1 - SPECIFICATIONS

1.8 DIMENSIONAL DATA

Table 1-8. Dimensional Data

Machine Height (stowed)	
E/M400AJP	6 ft. 7 in. (2.0 m)
E/M400AJNarrow	6 ft. 5.75 in. (1.31 m)
E/M 400A	6 ft. 7 in. (2.0 m)
E/M 400Anarrow	6 ft. 5.75 in. (1.97 m)
Machine Width	
E/M 400A	5 ft. 9 in. (1.75 m)
E/M 400Anarrow	4 ft. 11 in. (1.50 m)
E/M400AJP	5 ft. 9 in. (1.75 m.)
E/M400AJNarrow	4 ft. 11 in. (1.49 m.)
Machine Length (stowed)	
E/M 400A	18 ft. 1 in. (5.50 m)
E/M 400Anarrow	18 ft. 1 in. (5.50 m)
E/M400AJP	22.0ft. (6.7 m)
E/M400AJNarrow	22.0 ft. (6.7 m)
Wheel Base	6 ft. 7.0 in. (2.00 m)
Track Width	Track Width
E/M 400A, E/M400AJP	5 ft. 0 in. (1.51 m)
E/M 400Anarrow, E/M400AJNarrow	4 ft. 3.75 in.(1.31 m)
Ground Clearance	
E/M 400A, E/M400AJP	8.5 in. (0.22 m)
E/M 400Anarrow, E/M400AJNarrow	5 in. (0.13 m)
Working Height	46 ft. 0 in. (14.02 m)
Platform Height	40 ft. 0 in. (12.19 m)
Up and Over Platform Height	21 ft. 5 in. (6.55 m)
Horizontal Reach @ Maximum Up and Over	
E/M 400A, E/M 400Anarrow	21 ft. 2 in. (6.41 m)
E/M400AJP,E/M400AJNarrow	22 ft.-5 in. (6.83 m)
Tail Swing (Any Position)	Tail Swing (Any Position)
E/M 400A, E/M400AJP,E/M400AJNarrow	E/M 400A, E/M400AJP,E/
- 0 in.	M400AJNarrow - 0 in.
E/M 400Anarrow - 4 in.	E/M 400Anarrow - 4 in.
Turning Radius (Inside)	
E/M 400A	2 ft. 0 in. (0.61 m)
E/M 400Anarrow	2 ft. 10 in. (0.86 m)
E/M400AJP	2 ft.-0 in. (0.61 m)
E/M400AJNarrow	2 ft.-10 in. (0.86 m)
Turning Radius (outside)	10 ft. - 4 in. (3.15 m)

1.9 FUNCTION SPEEDS

Table 1-9. Function Speeds

Function	Seconds
Main Lift Up	30-24
Main Lift Down	29-23
Turntable Swing Right & Left 360°	81-67*
Telescope Out - E400AJP, M400AJP, E400AJPn, M400AJPn	10-6
Telescope Out - E400An, M400An, E400A, M400A	18-14
Telescope In - E400AJP, M400AJP, E400AJPn, M400AJPn	15-10
Telescope In - E400An, M400An, E400A, M400A	28-23
Platform Rotate (4 ft.) - Right & Left 180° - E400AJP, M400AJP, E400AJPn, M400AJPn	20-24**
Platform Rotate (5 ft.) - Right & Left 180° - E400AJP, M400AJP	16-19**
Platform Rotate - Right & Left 180° - E400An, M400An, E400A, M400A	17-14**
Jib Up	25-26
Jib Down	24-25
Jib Swing	18-25
Lower Lift Up	33-27
Lower Lift Down	26-22
High Drive - Fwd. & Rev. E400AJP/M400AJP (200 ft.)	42-44*** 3.2 mph. (5.1 kph)
High Drive - Fwd. & Rev. E400AJPn/M400AJPn (200 ft.)	45-50*** 3.0 mph. (4.8 kph)
Drive above Horiz. (ANSI) - Fwd. & Rev. E400A, E400AJP/M400A, M400AJP (50 ft.)	50-53*** 0.64 mph (1 kph)
Drive above Horiz. (ANSI) - Fwd. & Rev. E400An/ E400AJPn/M400n, M400AJPn (50 ft.)	78-85*** 0.44 mph. (0.7 kph)
Drive above Horiz. (CE) - Fwd. & Rev. E400AJP/ M400AJP (50 ft.)	107-112*** 0.32 mph (0.5 kph)
Drive above Horiz. (CE) - Fwd. & Rev. E400An/ E400AJPn/M400An/ M400AJPn (50 ft.)	78-85*** 0.44 mph. (0.7 kph)
Drive above Horiz. (CE) - Fwd. & Rev. E400A/M400A (50 ft.)	67-71*** 0.48 mph. (0.8 kph)
*Swing Left to Swing Right should be within 10% of each other.	
**Swing Left to Swing Right should be within 15% of each other.	
***Drive Forward to Drive Reverse should be within 10% of each other.	

4150273N

Machine Orientation When Doing Function Tests

1. **LIFT:**
Boom retracted, telescope retracted. Lift up, record time. Lift down, record time.
2. **SWING:**
Boom at full elevation, telescope retracted. Swing the turntable to the end stop. Swing the opposite direction. Record time. Swing the other direction, record time.
3. **TELESCOPE:**
Boom at full elevation, telescope retracted. Telescope out, record time. Telescope in, record time.
4. **DRIVE:**
Test should be done on a smooth, level surface. Start approximately 25 feet from starting point so that the unit is at a maximum speed when starting the test. Results should be recorded for a 200 foot course. Drive forward, record time. Drive reverse, record time.
5. **DRIVE (ABOVE HORIZONTAL):**
Test should be done on a smooth, level surface. The platform speed control knob should be selected out of creep speed. This verifies that the switches are working when the boom is above horizontal. Results should be recorded for a 50 ft. course. Drive forward, record time. Drive reverse, record time.
6. **PLATFORM ROTATE:**
Platform level and completely rotated one direction. Rotate the opposite direction, record time. Rotate the other direction, record time.
7. **JIB:**
Platform level and centered with the boom. Start with the jib down. Jib up, record time. Jib down, record time.

8. **LOWER LIFT:**
Upper boom horizontal, telescoped in. Lower lift up, record time. Lower lift down, record time.
9. **JIB SWING:**
Platform level and centered with the boom. Start with the jib horizontal. Begin with jib swing fully to left. Swing fully to right. Record time. Swing to the left, record time.

NOTE: Stop watch should be started with the function, not with the controller or switch.

All speed tests are run from the platform.

The platform speed control knob must be at full speed. (turned clockwise completely)

The function speeds may vary due to cold thick hydraulic oil. Tests should be run with oil temperature above 100° F. (38° C)

Some flow control functions may not work with the speed control knob in the creep position.

1.10 TORQUE SPECIFICATIONS

Table 1-10. Torque Requirements

Description	Torque Value	Interval Hours
Wheel Lugs	170 ft. lbs. (230Nm)	150
Swing Bearing (Loctite)	190ft. lbs.(260Nm)	50/600*

* Check swing bearing bolts for security after first 50 hours of operation and every 600 hours thereafter.

SECTION 1 - SPECIFICATIONS

1.11 CYLINDER SPECIFICATIONS

NOTE: All dimensions are given in inches (in.), with the metric equivalent, millimeters (mm), given in parentheses.

Table 1-11. Cylinder Specifications

Cylinder	Bore	Stroke	Rod Dia.
Upper Lift Cylinder	3.00 (76.2)	28.3125 (719.1)	1.50 (38.1)
Mid Lift Cylinder	3.00 (76.2)	21.25 (539.7)	1.50 (38.1)
Lower Lift Cylinder	4.00 (101.6)	23.25 (590.5)	2.25 (57.1)
Telescope Cylinder	2.00 (50.8)	92 (2337)	1.25 (31.8)
Master Cylinder (E/M400A)	2.00 (50.8)	9.375 (238.1)	1.00 (25.4)
Master Cylinder (E/M400AJP)	3.00 (75)	11.5 (292)	1.25 (32)
Slave Cylinder (E/M400A)	2.00 (50.8)	9.375 (238.1)	1.00 (25.4)
Slave Cylinder (E/M400AJP)	3.00 (75)	11.6 (295.5)	1.25 (32)
Rotator Cylinder	1.875 (47.6)	15.250 (387.3)	1.00 (25.4)
Steer Cylinder (Double Rod)	2.50 (63.5)	4.06 (103.1)	1.75 (44.5)
Jib Cylinder	63.5 (2.5)	233.6 (9.2)	44.5 (1.75)

1.12 MAJOR COMPONENT WEIGHTS

Table 1-12. Major Component Weights

Component	LB.	KG.
Platform and Support	215	97.5
Upper Boom Complete	810	367
Mid Boom Complete	550	249
Lower Boom Complete	550	249
Upper Lift Cylinder	89	40
Mid Lift Cylinder	95	43
Lower Lift Cylinder	110	50
Telescope Cylinder	85	38.5
Upper Upright	225	102
Lower Upright	97	44
Turntable	948	430
Battery Box (incl. batteries)	600	272
Chassis (w/ pneu. tires)	4,295	1948
Chassis (w/ foam-filled tires)	4,695	2130
Counterweight	3850	1746
Machine Complete	11,800	5352
Jib	320	145

WARNING

SELECT LIFTING EQUIPMENT WITH CAPACITY CAPABLE OF SAFELY SUPPORTING WEIGHT.

1.13 CRITICAL STABILITY WEIGHTS

Table 1-13. Critical Stability Weights

Component	KG.	LB.
Counterweight	1746	3850
Tire & Wheel (foam-filled)	94	207
Platform (4ft [1.2 m])	41	90
Platform (5 ft. [1.5 m])	45	100
Battery (each)	54	120

⚠ WARNING

DO NOT REPLACE ITEMS CRITICAL TO STABILITY WITH ITEMS OF DIFFERENT WEIGHT OR SPECIFICATION (FOR EXAMPLE: BATTERIES, FILLED TIRES, PLATFORM) DO NOT MODIFY UNIT IN ANY WAY TO AFFECT STABILITY.

1.14 PRESSURE SETTINGS

Table 1-14. Pressure Settings - Prior to S/N 0300062642

Circuit	PSI	Bar
Main Control Valve		
Lift Down Relief	550	38
Tower Lift Down Relief	1700	117
Telescope In Relief (A/AJ)	2150	148
Telescope In Relief (AJP)	3000	207
Platform Level Up Relief	2500	172
Platform Level Down Relief	1500	103
Brake/Steer Valve		
Steer Relief	2300	159
Steer Relief - AJPN	1100	76
Main Relief - E400A/M400A	3200	221
Main Relief - E400AJ/M400AJ	3400	234
Jib Valve		
Jib Relief (Up and Down)	1500	103
Jib Swing Relief	3000	207
Releving Valve		
Releving Relief	1200	83

Table 1-15. Pressure Settings - S/N 0300062642 to Present

Circuit	PSI	Bar
Main Control Valve		
Lift Down Relief	800	55
Tower Lift Down Relief (E/M400A) Prior to S/N 86022	1700	117
Tower Lift Down Relief (E/M400A) S/N 86022 to Present	2600	179
Tower Lift Down Relief (E/M400AJP) Prior to S/N 91053	1700	117
Tower Lift Down Relief (E/M400AJP) S/N 91053 to Present	2600	179
Telescope Relief (A)	3000	207
Telescope Relief (AJ & AJP)	3100	214
Platform Level Up Relief	3000	207
Platform Level Down Relief	1200	83
Brake/Steer Valve		
Steer Relief - AJP/A	2300	159
Steer Relief - An	1100	76
Steer Relief - AJPN	1400	96.5
Main Relief	3400	234
Jib Valve		
Jib Relief Up	2200	152
Jib Swing Relief	3000	207
Releving Valve		
Releving Relief (E/M400A) Prior to S/N 86022	1200	83
Releving Relief (E/M400A) S/N 86022 to Present	2200	152
Releving Relief (E/M400AJP) Prior to S/N 91053	1200	83
Releving Relief (E/M400AJP) S/N 91053 to Present	2200	152

SECTION 1 - SPECIFICATIONS

1.15 SERIAL NUMBER LOCATIONS

For machine identification, a serial number plate is affixed to the left rear of frame, in front of left rear wheel. If the serial number plate is damaged or missing, the machine serial number is stamped on the top left side of the frame and the top left side of the turntable. In addition, the serial number is stamped on top of the end of the upper boom, mid boom, and lower boom at the left rear of the booms.

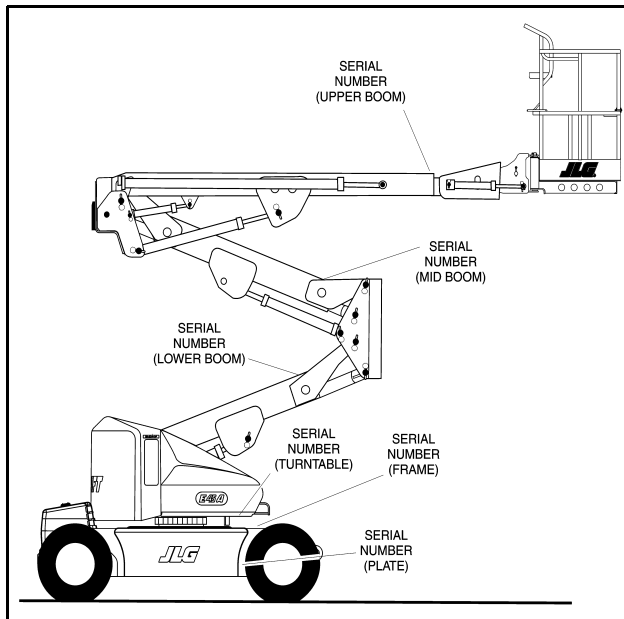

Figure 1-1. Serial Number Locations

1.16 LUBRICATION

Table 1-16. Hydraulic Oil

Hydraulic System Operating Temperature Range	S.A.E. Viscosity Grade
+0° to +180° F (-18° to +83° C)	10W
+0° to +210° F (-18° to +99° C)	10W-20, 10W30
+50° to +210° F (+10° to +99° C)	20W-20

NOTE: Hydraulic oils must have anti-wear qualities at least to API Service Classification GL-3, and sufficient chemical stability for mobile hydraulic system service.

Aside from JLG recommendations, it is not advisable to mix oils of different brands or types, as they may not contain the same required additives or be of comparable viscosities. If use of hydraulic oil other than Mobil DTE 11M is desired, contact JLG Industries for proper recommendations.

Lubrication Specifications

NOTE: Refer to Lubrication Chart, Figure 1-2, for specific lubrication procedures.

Table 1-17. Mobil DTE 11M Specs

ISO Viscosity Grade	#15
Gravity API	31.9
Pour Point, Max	-40°F (-40°C)
Flash Point, Min.	330°F (166°C)
Viscosity	
at 40° C	15 cSt
at 100° C	4.1 cSt
at 100° F	80 SUS
at 210° F	43 SUS
cp at -30° F	3.200
Viscosity Index	140

Table 1-18. Mobil EAL H Series Specs

Type	Synthetic Biodegradable
ISO Viscosity Grade	32
Specific Gravity	.950
Pour Point	-59°F (-51°C)
Flash Point	514°F (268°C)
Weight	7.64 lb. per gal. (0.9 kg per liter)
Viscosity	
at 40° C	33.1 cSt
at 100° C	6.36 cSt
Viscosity Index	147

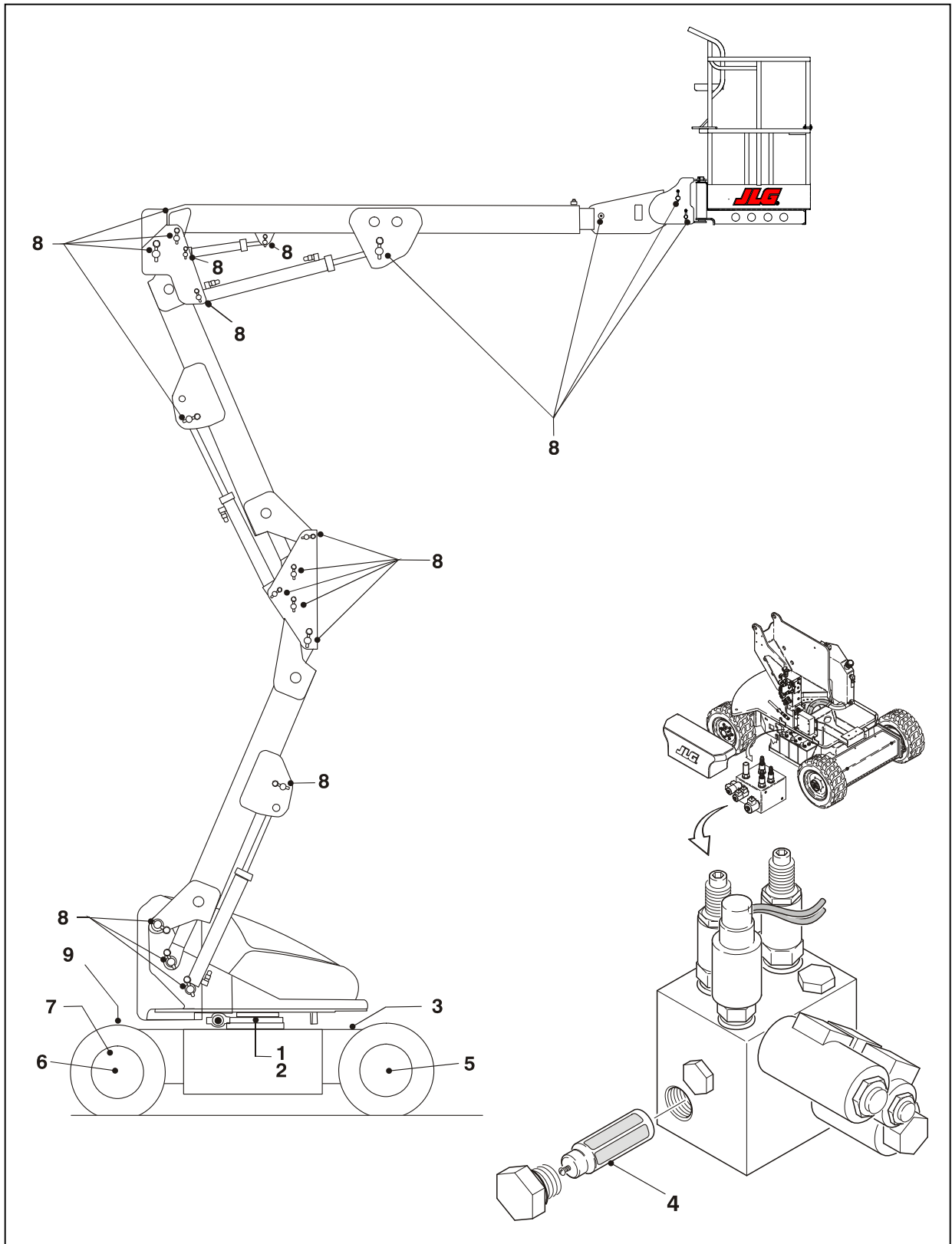

Figure 1-2. Operator Maintenance & Lubrication Diagram

SECTION 1 - SPECIFICATIONS

1.17 OPERATOR MAINTENANCE & LUBRICATION

NOTE: The following numbers correspond to those in Figure 1-2., Operator Maintenance & Lubrication Diagram.

Table 1-19. Lubrication Specifications.

KEY	SPECIFICATIONS
MPG	Multipurpose Grease having a minimum dripping point of 350 degrees F. Excellent water resistance and adhesive qualities; and being of extreme pressure type (Timken OK 40 pounds minimum).
EPGL	Extreme Pressure Gear Lube (oil) meeting API Service Classification GL-5 or Mil-Spec Mil-L-2105.
HO	Hydraulic Oil. Mobil DTE-11M
OG*	Open Gear Lube - Tribol Molub-Alloy 936 Open Gear Compound. (JLG Part No. 3020027)
BG*	Bearing Grease (JLG Part No. 3020029) Mobilith SHA 460.
LL	Synthetic Lithium Lubricant, Gredag 741 Grease. (JLG Part No. 3020022)
EO	Engine (crankcase) Oil. Gas - API SF/SG class, MIL-L-2104. Diesel - API CC/CD class, MIL-L-2104B/MIL-L-2104C.
*MPG may be substituted for these lubricants, if necessary, but service intervals will be reduced.	

NOTICE

LUBRICATION INTERVALS ARE BASED ON MACHINE OPERATION UNDER NORMAL CONDITIONS. FOR MACHINES USED IN MULTI-SHIFT OPERATIONS AND/OR EXPOSED TO HOSTILE ENVIRONMENTS OR CONDITIONS, LUBRICATION FREQUENCIES MUST BE INCREASED ACCORDINGLY.

1. Swing Bearing

Lube Point(s) - 2 Grease Fittings
 Capacity - A/R
 Lube - MPG
 Interval - Every 3 months or 150 hrs of operation
 Comments - Remote Access

2. Swing Bearing/Worm Gear Teeth

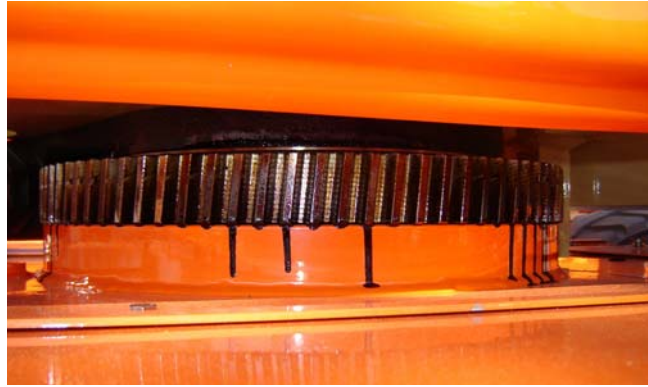

Lube Point(s) - 2 Grease Fittings
 Capacity - Spray On
 Lube - Mobilnac 375NC
 Interval - A/R
 Comments - If necessary install grease fittings into worm gear housing and grease bearings.

DO NOT OVERGREASE BEARINGS. OVERGREASING BEARINGS WILL RESULT IN BLOWING OUTER SEAL IN HOUSING.

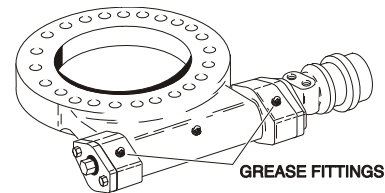

3. Hydraulic Tank



Lube Point(s) - Fill Cap
 Capacity - 4 Gal. (15.1 L)
 Lube - HO
 Interval - Check Level daily; Change every 2 years or 1200 hours of operation.
 Comments - On new machines, those recently overhauled, or after changing hydraulic oil, operate all systems a minimum of two complete cycles and recheck oil level in reservoir.

4. Hydraulic Return Filter

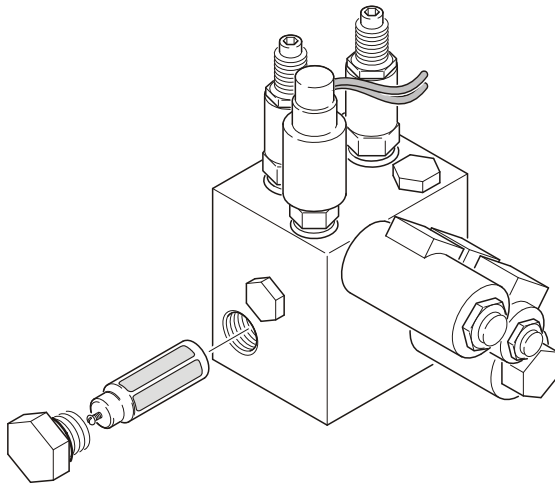

Interval - Change after first 50 hrs. and every 6 months or 300 hrs. thereafter.

Comments - Under certain conditions, it may be necessary to replace the hydraulic filter on a more frequent basis. A common symptom of a dirty filter is sluggishness experienced in hydraulic functions.

5. Wheel Drive Hub



Lube Point(s) - Level/Fill Plug

Capacity - 17 oz. (1/2 Full)

Lube - EPGL

Interval - Check level every 3 months or 150 hrs of operation; change every 2 years or 1200 hours of operation

6. Wheel Bearings

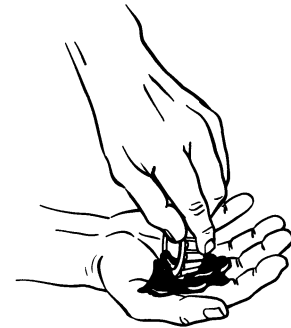

Lube Point(s) - Repack

Capacity - A/R

Lube - MPG

Interval - Every 2 years or 1200 hours of operation

7. Spindles/Bushing

Capacity - A/R

Lube - Lithium Lubricant

Interval - Every 2 years or 1200 hours of operation

Comments - At Spindle/Bushing Replacement; Coat I.D. of bushings prior to installing king pins.

8. Boom Pivot Pins/Bushing

Capacity - A/R

Lube - Lithium Lubricant

Interval - Every 2 years or 1200 hours of operation

Comments - At boom pivot pins/bushing replacement; Coat I.D. of bushings prior to installing pivot pins.

SECTION 1 - SPECIFICATIONS

9. Engine

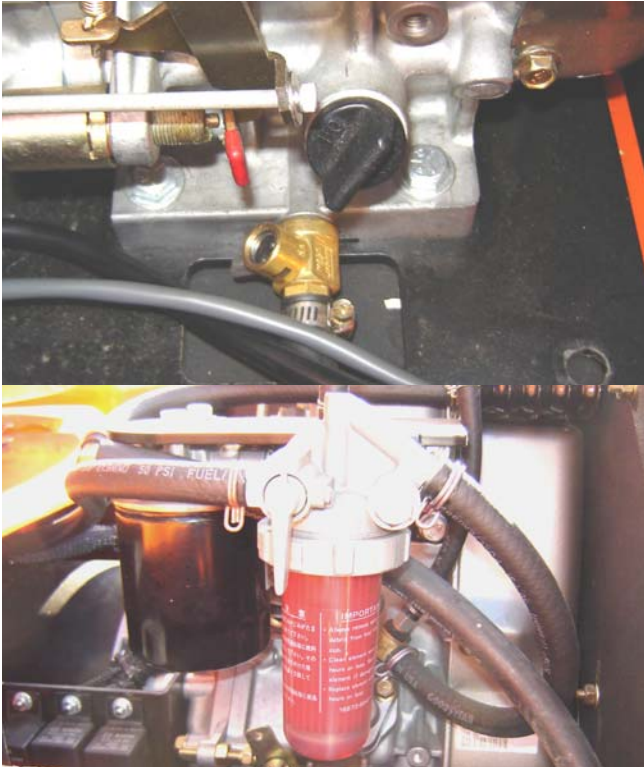

Lube Point(s) - Fill Cap

Capacity - Refer to Engine Manual

Lube - EO

Interval - 3 Months or 150 hours of operation

Comments - Check level daily/Change in accordance with engine manual.

Values for Zinc Yellow Chromate Fasteners (Ref 4150707)

SAE GRADE 5 BOLTS & GRADE 2 NUTS

Size	TPI	Bolt Dia	Tensile Stress Area	Clamp Load	Torque (Dry)		Torque Lubricated		Torque (Loctite® 242™ or 271™ OR Vibra-TITE™ 111 or 140)		Torque (Loctite® 262™ or Vibra-TITE™ 131)	
					IN-LB	[N.m]	IN-LB	[N.m]	IN-LB	[N.m]	IN-LB	[N.m]
		In	Sq In	LB								
4	40	0.1120	0.00604	380	8	0.9	6	0.7				
	48	0.1120	0.00661	420	9	1.0	7	0.8				
6	32	0.1380	0.00909	580	16	1.8	12	1.4				
	40	0.1380	0.01015	610	18	2.0	13	1.5				
8	32	0.1640	0.01400	900	30	3.4	22	2.5				
	36	0.1640	0.01474	940	31	3.5	23	2.6				
10	24	0.1900	0.01750	1120	43	4.8	32	3.5				
	32	0.1900	0.02000	1285	49	5.5	36	4				
1/4	20	0.2500	0.0318	2020	96	10.8	75	9	105	12		
	28	0.2500	0.0364	2320	120	13.5	86	10	135	15		
		In	Sq In	LB	FT-LB	[N.m]	FT-LB	[N.m]	FT-LB	[N.m]	FT-LB	[N.m]
5/16	18	0.3125	0.0524	3340	17	23	13	18	19	26	16	22
	24	0.3125	0.0580	3700	19	26	14	19	21	29	17	23
3/8	16	0.3750	0.0775	4940	30	41	23	31	35	48	28	38
	24	0.3750	0.0878	5600	35	47	25	34	40	54	32	43
7/16	14	0.4375	0.1063	6800	50	68	35	47	55	75	45	61
	20	0.4375	0.1187	7550	55	75	40	54	60	82	50	68
1/2	13	0.5000	0.1419	9050	75	102	55	75	85	116	68	92
	20	0.5000	0.1599	10700	90	122	65	88	100	136	80	108
9/16	12	0.5625	0.1820	11600	110	149	80	108	120	163	98	133
	18	0.5625	0.2030	12950	120	163	90	122	135	184	109	148
5/8	11	0.6250	0.2260	14400	150	203	110	149	165	224	135	183
	18	0.6250	0.2560	16300	170	230	130	176	190	258	153	207
3/4	10	0.7500	0.3340	21300	260	353	200	271	285	388	240	325
	16	0.7500	0.3730	23800	300	407	220	298	330	449	268	363
7/8	9	0.8750	0.4620	29400	430	583	320	434	475	646	386	523
	14	0.8750	0.5090	32400	470	637	350	475	520	707	425	576
1	8	1.0000	0.6060	38600	640	868	480	651	675	918	579	785
	12	1.0000	0.6630	42200	700	949	530	719	735	1000	633	858
1 1/8	7	1.1250	0.7630	42300	800	1085	600	813	840	1142	714	968
	12	1.1250	0.8560	47500	880	1193	660	895	925	1258	802	1087
1 1/4	7	1.2500	0.9690	53800	1120	1518	840	1139	1175	1598	1009	1368
	12	1.2500	1.0730	59600	1240	1681	920	1247	1300	1768	1118	1516
1 3/8	6	1.3750	1.1550	64100	1460	1979	1100	1491	1525	2074	1322	1792
	12	1.3750	1.3150	73000	1680	2278	1260	1708	1750	2380	1506	2042
1 1/2	6	1.5000	1.4050	78000	1940	2630	1460	1979	2025	2754	1755	2379
	12	1.5000	1.5800	87700	2200	2983	1640	2224	2300	3128	1974	2676

NO. 500059 REV. J

- NOTES: 1. THESE TORQUE VALUES DO NOT APPLY TO CADMIUM PLATED FASTENERS
 2. ALL TORQUE VALUES ARE STATIC TORQUE MEASURED PER STANDARD AUDIT METHODS TOLERANCE = ±10%
 3. * ASSEMBLY USES HARDENED WASHER

REFERENCE JLG ANEROBIC THREAD LOCKING COMPOUND				
JLG P/N	Loctite® P/N		ND Industries P/N	Description
0100011	242™		Vibra-TITE™ 121	Medium Strength (Blue)
0100019	271™		Vibra-TITE™ 140	High Strength (Red)
0100071	262™		Vibra-TITE™ 131	Medium - High Strength (Red)

Figure 1-3. Torque Chart (SAE Fasteners - Sheet 1 of 7)

SECTION 1 - SPECIFICATIONS

Values for Zinc Yellow Chromate Fasteners (Ref 4150707)										
SAE GRADE 8 (HEX HD) BOLTS & GRADE 8 NUTS*										
Size	TPI	Bolt Dia	Tensile Stress Area	Clamp Load	Torque (Dry or Loctite® 263) K= 0.20		Torque (Loctite® 242™ or 271™ OR Vibra-TITE™ 111 or 140) K=.18		Torque (Loctite® 262™ or Vibra-TITE™ 131) K=0.15	
					IN-LB	[N.m]	IN-LB	[N.m]	IN-LB	[N.m]
		In	Sq In	LB	FT-LB	[N.m]	FT-LB	[N.m]	FT-LB	[N.m]
4	40	0.1120	0.00604							
	48	0.1120	0.00661							
6	32	0.1380	0.00909							
	40	0.1380	0.01015							
8	32	0.1640	0.01400							
	36	0.1640	0.01474	1320	43	5				
10	24	0.1900	0.01750	1580	60	7				
	32	0.1900	0.02000	1800	68	8				
1/4	20	0.2500	0.0318	2860	143	16	129	15		
	28	0.2500	0.0364	3280	164	19	148	17		
		In	Sq In	LB	FT-LB	[N.m]	FT-LB	[N.m]	FT-LB	[N.m]
5/16	18	0.3125	0.0524	4720	25	35	20	25	20	25
	24	0.3125	0.0580	5220	25	35	25	35	20	25
3/8	16	0.3750	0.0775	7000	45	60	40	55	35	50
	24	0.3750	0.0878	7900	50	70	45	60	35	50
7/16	14	0.4375	0.1063	9550	70	95	65	90	50	70
	20	0.4375	0.1187	10700	80	110	70	95	60	80
1/2	13	0.5000	0.1419	12750	105	145	95	130	80	110
	20	0.5000	0.1599	14400	120	165	110	150	90	120
9/16	12	0.5625	0.1820	16400	155	210	140	190	115	155
	18	0.5625	0.2030	18250	170	230	155	210	130	175
5/8	11	0.6250	0.2260	20350	210	285	190	260	160	220
	18	0.6250	0.2560	23000	240	325	215	290	180	245
3/4	10	0.7500	0.3340	30100	375	510	340	460	280	380
	16	0.7500	0.3730	33600	420	570	380	515	315	430
7/8	9	0.8750	0.4620	41600	605	825	545	740	455	620
	14	0.8750	0.5090	45800	670	910	600	815	500	680
1	8	1.0000	0.6060	51500	860	1170	770	1045	645	875
	12	1.0000	0.6630	59700	995	1355	895	1215	745	1015
1 1/8	7	1.1250	0.7630	68700	1290	1755	1160	1580	965	1310
	12	1.1250	0.8560	77000	1445	1965	1300	1770	1085	1475
1 1/4	7	1.2500	0.9690	87200	1815	2470	1635	2225	1365	1855
	12	1.2500	1.0730	96600	2015	2740	1810	2460	1510	2055
1 3/8	6	1.3750	1.1550	104000	2385	3245	2145	2915	1785	2430
	12	1.3750	1.3150	118100	2705	3680	2435	3310	2030	2760
1 1/2	6	1.5000	1.4050	126500	3165	4305	2845	3870	2370	3225
	12	1.5000	1.5800	142200	3555	4835	3200	4350	2665	3625

NO. 500059 REV. J
 NOTES: 1. THESE TORQUE VALUES DO NOT APPLY TO CADMIUM PLATED FASTENERS
 2. ALL TORQUE VALUES ARE STATIC TORQUE MEASURED PER STANDARD AUDIT METHODS TOLERANCE = ±10%
 3. * ASSEMBLY USES HARDENED WASHER

Figure 1-4. Torque Chart (SAE Fasteners - Sheet 2 of 7)

SOCKET HEAD CAP SCREWS										
Magni Coating (Ref 4150701)*										
Size	TPI	Bolt Dia	Tensile Stress Area	Clamp Load See Note 4	Torque (Dry) K = .17		Torque (Loctite® 242™ or 271™ OR Vibra-TITE™ 111 or 140 OR Precoat 85® K=0.16		Torque (Loctite® 262™ or Vibra-TITE™ 131) K=0.15	
					IN-LB	[N.m]	IN-LB	[N.m]	IN-LB	[N.m]
		In	Sq In	LB						
4	40	0.1120	0.00604							
	48	0.1120	0.00661							
6	32	0.1380	0.00909							
	40	0.1380	0.01015							
8	32	0.1640	0.01400							
	36	0.1640	0.01474							
10	24	0.1900	0.01750							
	32	0.1900	0.02000							
1/4	20	0.2500	0.0318	2860	122	14	114	13		
	28	0.2500	0.0364	3280	139	16	131	15		
		In	Sq In	LB	FT-LB	[N.m]	FT-LB	[N.m]	FT-LB	[N.m]
5/16	18	0.3125	0.0524	4720	20	25	20	25	20	25
	24	0.3125	0.0580	5220	25	35	20	25	20	25
3/8	16	0.3750	0.0775	7000	35	50	35	50	35	50
	24	0.3750	0.0878	7900	40	55	40	55	35	50
7/16	14	0.4375	0.1063	9550	60	80	55	75	50	70
	20	0.4375	0.1187	10700	65	90	60	80	60	80
1/2	13	0.5000	0.1419	12750	90	120	85	115	80	110
	20	0.5000	0.1599	14400	100	135	95	130	90	120
9/16	12	0.5625	0.1820	16400	130	175	125	170	115	155
	18	0.5625	0.2030	18250	145	195	135	185	130	175
5/8	11	0.6250	0.2260	20350	180	245	170	230	160	220
	18	0.6250	0.2560	23000	205	280	190	260	180	245
3/4	10	0.7500	0.3340	30100	320	435	300	410	280	380
	16	0.7500	0.3730	33600	355	485	335	455	315	430
7/8	9	0.8750	0.4620	41600	515	700	485	660	455	620
	14	0.8750	0.5090	45800	570	775	535	730	500	680
1	8	1.0000	0.6060	51500	730	995	685	930	645	875
	12	1.0000	0.6630	59700	845	1150	795	1080	745	1015
1 1/8	7	1.1250	0.7630	68700	1095	1490	1030	1400	965	1310
	12	1.1250	0.8560	77000	1225	1665	1155	1570	1085	1475
1 1/4	7	1.2500	0.9690	87200	1545	2100	1455	1980	1365	1855
	12	1.2500	1.0730	96600	1710	2325	1610	2190	1510	2055
1 3/8	6	1.3750	1.1550	104000	2025	2755	1905	2590	1785	2430
	12	1.3750	1.3150	118100	2300	3130	2165	2945	2030	2760
1 1/2	6	1.5000	1.4050	126500	2690	3660	2530	3440	2370	3225
	12	1.5000	1.5800	142200	3020	4105	2845	3870	2665	3625

NO. 5000059 REV. J

- NOTES: 1. THESE TORQUE VALUES DO NOT APPLY TO CADMIUM PLATED FASTENERS
 2. ALL TORQUE VALUES ARE STATIC TORQUE MEASURED PER STANDARD AUDIT METHODS TOLERANCE = ±10%
 *3. ASSEMBLY USES HARDENED WASHER OR FASTENER IS PLACED AGAINST PLATED STEEL OR RAW ALUMINUM
 4. CLAMP LOAD LISTED FOR SHCS IS SAME AS GRADE 8 OR CLASS 10.9 AND DOES NOT REPRESENT FULL STRENGTH CAPABILITY OF SHCS. IF HIGHER LOAD IS REQUIRED, ADDITIONAL TESTING IS REQUIRED.

Figure 1-5. Torque Chart (SAE Fasteners - Sheet 3 of 7)

SECTION 1 - SPECIFICATIONS

SOCKET HEAD CAP SCREWS										
Zinc Yellow Chromate Fasteners (Ref 4150707)*										
Size	TPI	Bolt Dia	Tensile Stress Area	Clamp Load See Note 4	Torque (Dry) K = .20		Torque (Loctite® 242™ or 271™ OR Vibra-TITE™ 111 or 140 OR Precoat 85® K=0.18		Torque (Loctite® 262™ or Vibra-TITE™ 131) K=0.15	
					IN-LB	[N.m]	IN-LB	[N.m]	IN-LB	[N.m]
		In	Sq In	LB						
4	40	0.1120	0.00604							
	48	0.1120	0.00661							
6	32	0.1380	0.00909							
	40	0.1380	0.01015							
8	32	0.1640	0.01400							
	36	0.1640	0.01474							
10	24	0.1900	0.01750							
	32	0.1900	0.02000							
1/4	20	0.2500	0.0318	2860	143	16	129	15		
	28	0.2500	0.0364	3280	164	19	148	17		
		In	Sq In	LB	FT-LB	[N.m]	FT-LB	[N.m]	FT-LB	[N.m]
5/16	18	0.3125	0.0524	4720	25	35	20	25	20	25
	24	0.3125	0.0580	5220	25	35	25	35	20	25
3/8	16	0.3750	0.0775	7000	45	60	40	55	35	50
	24	0.3750	0.0878	7900	50	70	45	60	35	50
7/16	14	0.4375	0.1063	9550	70	95	65	90	50	70
	20	0.4375	0.1187	10700	80	110	70	95	60	80
1/2	13	0.5000	0.1419	12750	105	145	95	130	80	110
	20	0.5000	0.1599	14400	120	165	110	150	90	120
9/16	12	0.5625	0.1820	16400	155	210	140	190	115	155
	18	0.5625	0.2030	18250	170	230	155	210	130	175
5/8	11	0.6250	0.2260	20350	210	285	190	260	160	220
	18	0.6250	0.2560	23000	240	325	215	290	180	245
3/4	10	0.7500	0.3340	30100	375	510	340	460	280	380
	16	0.7500	0.3730	33600	420	570	380	515	315	430
7/8	9	0.8750	0.4620	41600	605	825	545	740	455	620
	14	0.8750	0.5090	45800	670	910	600	815	500	680
1	8	1.0000	0.6060	51500	860	1170	775	1055	645	875
	12	1.0000	0.6630	59700	995	1355	895	1215	745	1015
1 1/8	7	1.1250	0.7630	68700	1290	1755	1160	1580	965	1310
	12	1.1250	0.8560	77000	1445	1965	1300	1770	1085	1475
1 1/4	7	1.2500	0.9690	87200	1815	2470	1635	2225	1365	1855
	12	1.2500	1.0730	96600	2015	2740	1810	2460	1510	2055
1 3/8	6	1.3750	1.1550	104000	2385	3245	2145	2915	1785	2430
	12	1.3750	1.3150	118100	2705	3680	2435	3310	2030	2760
1 1/2	6	1.5000	1.4050	126500	3165	4305	2845	3870	2370	3225
	12	1.5000	1.5800	142200	3555	4835	3200	4350	2665	3625

NO. 500059 REV. J

- NOTES: 1. THESE TORQUE VALUES DO NOT APPLY TO CADMIUM PLATED FASTENERS
 2. ALL TORQUE VALUES ARE STATIC TORQUE MEASURED PER STANDARD AUDIT METHODS TOLERANCE = ±10%
 *3. ASSEMBLY USES HARDENED WASHER OR FASTENER IS PLACED AGAINST PLATED STEEL OR RAW ALUMINUM
 4. CLAMP LOAD LISTED FOR SHCS IS SAME AS GRADE 8 OR CLASS 10.9 AND DOES NOT REPRESENT FULL STRENGTH CAPABILITY OF SHCS. IF HIGHER LOAD IS REQUIRED, ADDITIONAL TESTING IS REQUIRED.

Figure 1-6. Torque Chart (SAE Fasteners - Sheet 4 of 7)

Values for Zinc Yellow Chromate Fasteners (Ref 4150707)							
CLASS 8.8 METRIC BOLTS CLASS 8 METRIC NUTS							
Size	PITCH	Tensile Stress Area	Clamp Load	Torque (Dry or Loctite® 263™)	Torque (Lub)	Torque (Loctite® 262™ OR Vibra-TITE™ 131)	Torque (Loctite® 242™ or 271™ OR Vibra-TITE™ 111 or 140)
		Sq mm	KN	[N.m]	[N.m]	[N.m]	[N.m]
3	0.5	5.03	2.19	1.3	1.0	1.2	1.4
3.5	0.6	6.78	2.95	2.1	1.6	1.9	2.3
4	0.7	8.78	3.82	3.1	2.3	2.8	3.4
5	0.8	14.20	6.18	6.2	4.6	5.6	6.8
6	1	20.10	8.74	11	7.9	9.4	12
7	1	28.90	12.6	18	13	16	19
8	1.25	36.60	15.9	26	19	23	28
10	1.5	58.00	25.2	50	38	45	55
12	1.75	84.30	36.7	88	66	79	97
14	2	115	50.0	140	105	126	154
16	2	157	68.3	219	164	197	241
18	2.5	192	83.5	301	226	271	331
20	2.5	245	106.5	426	320	383	469
22	2.5	303	132.0	581	436	523	639
24	3	353	153.5	737	553	663	811
27	3	459	199.5	1080	810	970	1130
30	3.5	561	244.0	1460	1100	1320	1530
33	3.5	694	302.0	1990	1490	1790	2090
36	4	817	355.5	2560	1920	2300	2690
42	4.5	1120	487.0	4090	3070	3680	4290

NO. 500059 REV. J

- NOTES: 1. THESE TORQUE VALUES DO NOT APPLY TO CADMIUM PLATED FASTENERS
 2. ALL TORQUE VALUES ARE STATIC TORQUE MEASURED PER STANDARD AUDIT METHODS TOLERANCE = ±10%
 *3. ASSEMBLY USES HARDENED WASHER OR FASTENER IS PLACED AGAINST PLATED STEEL OR RAW ALUMINUM
 4. CLAMP LOAD LISTED FOR SHCS IS SAME AS GRADE 8 OR CLASS 10.9 AND DOES NOT REPRESENT FULL STRENGTH CAPABILITY OF SHCS. IF HIGHER LOAD IS REQUIRED, ADDITIONAL TESTING IS REQUIRED.

Figure 1-7. Torque Chart (METRIC Fasteners - Sheet 5 of 7)

SECTION 1 - SPECIFICATIONS

Values for Zinc Yellow Chromate Fasteners (Ref 4150707)						
CLASS 10.9 METRIC BOLTS CLASS 10 METRIC NUTS CLASS 12.9 SOCKET HEAD CAP SCREWS M3 - M5*						
Size	PITCH	Tensile Stress Area	Clamp Load	Torque (Dry or Loctite® 263™) K = 0.20	Torque (Lub OR Loctite® 242™ or 271™ OR Vibra-TITE™ 111 or 140) K= 0.18	Torque (Loctite® 262™ OR Vibra-TITE™ 131) K=0.15
		Sq mm	KN	[N.m]	[N.m]	[N.m]
3	0.5	5.03	3.13			
3.5	0.6	6.78	4.22			
4	0.7	8.78	5.47			
5	0.8	14.20	8.85			
6	1	20.10	12.5			
7	1	28.90	18.0	25.2	22.7	18.9
8	1.25	36.60	22.8	36.5	32.8	27.4
10	1.5	58.00	36.1	70	65	55
12	1.75	84.30	52.5	125	115	95
14	2	115	71.6	200	180	150
16	2	157	97.8	315	280	235
18	2.5	192	119.5	430	385	325
20	2.5	245	152.5	610	550	460
22	2.5	303	189.0	830	750	625
24	3	353	222.0	1065	960	800
27	3	459	286.0	1545	1390	1160
30	3.5	561	349.5	2095	1885	1575
33	3.5	694	432.5	2855	2570	2140
36	4	817	509.0	3665	3300	2750
42	4.5	1120	698.0	5865	5275	4395

NO. 500059 REV. J

- NOTES: 1. THESE TORQUE VALUES DO NOT APPLY TO CADMIUM PLATED FASTENERS
 2. ALL TORQUE VALUES ARE STATIC TORQUE MEASURED PER STANDARD AUDIT METHODS TOLERANCE = ±10%
 *3. ASSEMBLY USES HARDENED WASHER OR FASTENER IS PLACED AGAINST PLATED STEEL OR RAW ALUMINUM
 4. CLAMP LOAD LISTED FOR SHCS IS SAME AS GRADE 8 OR CLASS 10.9 AND DOES NOT REPRESENT FULL STRENGTH CAPABILITY OF SHCS. IF HIGHER LOAD IS REQUIRED, ADDITIONAL TESTING IS REQUIRED.

Figure 1-8. Torque Chart (METRIC Fasteners - Sheet 6 of 7)

Magni Coating (Ref 4150701)*						
CLASS 12.9 SOCKET HEAD CAP SCREWS M6 AND ABOVE*						
Size	PITCH	Tensile Stress Area	Clamp Load See Note 4	Torque (Dry or Loctite® 263™) K = .17	Torque (Lub OR Loctite® 242™ or 271™ OR Vibra-TITE™ 111 or 140) K = .16	Torque (Loctite® 262™ OR Vibra-TITE™ 131) K = .15
		Sq mm	kN	[N.m]	[N.m]	[N.m]
3	0.5	5.03				
3.5	0.6	6.78				
4	0.7	8.78				
5	0.8	14.20				
6	1	20.10	12.5	13	12	11
7	1	28.90	18.0	21	20	19
8	1.25	36.60	22.8	31	29	27
10	1.5	58.00	36.1	61	58	54
12	1.75	84.30	52.5	105	100	95
14	2	115	71.6	170	160	150
16	2	157	97.8	265	250	235
18	2.5	192	119.5	365	345	325
20	2.5	245	152.5	520	490	460
22	2.5	303	189.0	705	665	625
24	3	353	220.0	900	845	790
27	3	459	286.0	1315	1235	1160
30	3.5	561	349.5	1780	1680	1575
33	3.5	694	432.5	2425	2285	2140
36	4	817	509.0	3115	2930	2750
42	4.5	1120	698.0	4985	4690	4395

NO. 500059 REV. J

- NOTES: 1. THESE TORQUE VALUES DO NOT APPLY TO CADMIUM PLATED FASTENERS
 2. ALL TORQUE VALUES ARE STATIC TORQUE MEASURED PER STANDARD AUDIT METHODS TOLERANCE = ±10%
 *3. ASSEMBLY USES HARDENED WASHER OR FASTENER IS PLACED AGAINST PLATED STEEL OR RAW ALUMINUM
 4. CLAMP LOAD LISTED FOR SHCS IS SAME AS GRADE 8 OR CLASS 10.9 AND DOES NOT REPRESENT FULL STRENGTH CAPABILITY OF SHCS. IF HIGHER LOAD IS REQUIRED, ADDITIONAL TESTING IS REQUIRED.

Figure 1-9. Torque Chart (METRIC Fasteners - Sheet 7 of 7)

SECTION 2. GENERAL

2.1 MACHINE PREPARATION, INSPECTION, AND MAINTENANCE

General

This section provides the necessary information needed by those personnel that are responsible to place the machine in operation readiness and maintain its safe operating condition. For maximum service life and safe operation, ensure that all the necessary inspections and maintenance have been completed before placing the machine into service.

Preparation, Inspection, and Maintenance

It is important to establish and conform to a comprehensive inspection and preventive maintenance program. The following table outlines the periodic machine inspections and maintenance recommended by JLG Industries, Inc. Consult your national, regional, or local regulations for further requirements for aerial work platforms. The frequency of inspections and maintenance must be increased as environment, severity and frequency of usage requires.

Pre-Start Inspection

It is the User's or Operator's primary responsibility to perform a Pre-Start Inspection of the machine prior to use daily or at each change of operator. Reference the Operator's and Safety Manual for completion procedures for the Pre-Start Inspection. The Operator and Safety Manual must be read in its entirety and understood prior to performing the Pre-Start Inspection.

Pre-Delivery Inspection and Frequent Inspection

The Pre-Delivery Inspection and Frequent Inspection shall be performed by a qualified JLG equipment mechanic. JLG Industries, Inc. recognizes a qualified JLG equipment mechanic as a person who, by possession of a recognized degree, certificate, extensive knowledge, training, or experience, has successfully demonstrated the ability and proficiency to service, repair, and maintain the subject JLG product model.

The Pre-Delivery Inspection and Frequent Inspection procedures are performed in the same manner, but at different times. The Pre-Delivery Inspection shall be performed prior to each sale, lease, or rental delivery. The Frequent Inspection shall be accomplished for each machine in service for 3 months or 150 hours (whichever comes first); out of service for a period of more than 3 months; or when purchased used. The frequency of this inspection must be increased as environment, severity and frequency of usage requires.

Reference the JLG Pre-Delivery and Frequent Inspection Form and the Inspection and Preventive Maintenance Schedule for items requiring inspection during the performance of these inspections. Reference the appropriate areas of this manual for servicing and maintenance procedures.

Annual Machine Inspection

The Annual Machine Inspection must be performed by a Factory-Certified Service Technician on an annual basis, no later than thirteen (13) months from the date of the prior Annual Machine Inspection. JLG Industries, Inc. recognizes a Factory-Certified Service Technician as a person who has successfully completed the JLG Service Training School for the subject JLG product model. Reference the machine Service and Maintenance Manual and appropriate JLG inspection form for performance of this inspection.

Reference the JLG Annual Machine Inspection Form and the Inspection and Preventive Maintenance Schedule for items requiring inspection during the performance of this inspection. Reference the appropriate areas of this manual for servicing and maintenance procedures.

For the purpose of receiving safety-related bulletins, it is important that JLG Industries, Inc. has updated ownership information for each machine. When performing each Annual Machine Inspection, notify JLG Industries, Inc. of the current machine ownership.

Preventive Maintenance

In conjunction with the specified inspections, maintenance shall be performed by a qualified JLG equipment mechanic. JLG Industries, Inc. recognizes a qualified JLG equipment mechanic as a person who, by possession of a recognized degree, certificate, extensive knowledge, training, or experience, has successfully demonstrated the ability and proficiency to service, repair, and maintain the subject JLG product model.

Reference the Preventive Maintenance Schedule and the appropriate areas of this manual for servicing and maintenance procedures. The frequency of service and maintenance must be increased as environment, severity and frequency of usage requires.

Table 2-1. Inspection and Maintenance

Type	Frequency	Primary Responsibility	Service Qualification	Reference
Pre-Start Inspection	Prior to use each day; or At each Operator change.	User or Operator	User or Operator	Operator and Safety Manual
Pre-Delivery Inspection	Prior to each sale, lease, or rental delivery.	Owner, Dealer, or User	Qualified JLG Mechanic	Service and Maintenance Manual and applicable JLG inspection form.
Frequent Inspection	In service for 3 months or 150 hours, which- ever comes first; or Out of service for a period of more than 3 months; or Purchased used.	Owner, Dealer, or User	Qualified JLG Mechanic	Service and Maintenance Manual and applicable JLG inspection form.
Annual Machine Inspection	Annually, no later than 13 months from the date of the prior inspection.	Owner, Dealer, or User	Factory-Trained Service Technician (Recommended)	Service and Maintenance Manual and applicable JLG inspection form.
Preventive Maintenance	At intervals as specified in the Service and Maintenance Manual.	Owner, Dealer, or User	Qualified JLG Mechanic	Service and Maintenance Manual

2.2 SERVICE AND GUIDELINES

General

The following information is provided to assist you in the use and application of servicing and maintenance procedures contained in this book.

Safety and Workmanship

Your safety, and that of others, is the first consideration when engaging in the maintenance of equipment. Always be conscious of weight. Never attempt to move heavy parts without the aid of a mechanical device. Do not allow heavy objects to rest in an unstable position. When raising a portion of the equipment, ensure that adequate support is provided.

Cleanliness

1. The most important single item in preserving the long service life of a machine is to keep dirt and foreign materials out of the vital components. Precautions have been taken to safeguard against this. Shields, covers, seals, and filters are provided to keep air, fuel, and oil supplies clean; however, these items must be maintained on a scheduled basis in order to function properly.

2. At any time when air, fuel, or oil lines are disconnected, clear adjacent areas as well as the openings and fittings themselves. As soon as a line or component is disconnected, cap or cover all openings to prevent entry of foreign matter.
3. Clean and inspect all parts during servicing or maintenance, and assure that all passages and openings are unobstructed. Cover all parts to keep them clean. Be sure all parts are clean before they are installed. New parts should remain in their containers until they are ready to be used.

Components Removal and Installation

1. Use adjustable lifting devices, whenever possible, if mechanical assistance is required. All slings (chains, cables, etc.) should be parallel to each other and as near perpendicular as possible to top of part being lifted.
2. Should it be necessary to remove a component on an angle, keep in mind that the capacity of an eye-bolt or similar bracket lessens, as the angle between the supporting structure and the component becomes less than 90 degrees.
3. If a part resists removal, check to see whether all nuts, bolts, cables, brackets, wiring, etc., have been removed and that no adjacent parts are interfering.

Component Disassembly and Reassembly

When disassembling or reassembling a component, complete the procedural steps in sequence. Do not partially disassemble or assemble one part, then start on another. Always recheck your work to assure that nothing has been overlooked. Do not make any adjustments, other than those recommended, without obtaining proper approval.

Pressure-Fit Parts

When assembling pressure-fit parts, use an anti-seize or molybdenum disulfide base compound to lubricate the mating surface.

Bearings

1. When a bearing is removed, cover it to keep out dirt and abrasives. Clean bearings in nonflammable cleaning solvent and allow to drip dry. Compressed air can be used but do not spin the bearing.
2. Discard bearings if the races and balls (or rollers) are pitted, scored, or burned.
3. If bearing is found to be serviceable, apply a light coat of oil and wrap it in clean (waxed) paper. Do not unwrap reusable or new bearings until they are ready to install.
4. Lubricate new or used serviceable bearings before installation. When pressing a bearing into a retainer or bore, apply pressure to the outer race. If the bearing is to be installed on a shaft, apply pressure to the inner race.

Gaskets

Check that holes in gaskets align with openings in the mating parts. If it becomes necessary to hand-fabricate a gasket, use gasket material or stock of equivalent material and thickness. Be sure to cut holes in the right location, as blank gaskets can cause serious system damage.

Bolt Usage and Torque Application

1. Use bolts of proper length. A bolt which is too long will bottom before the head is tight against its related part. If a bolt is too short, there will not be enough thread area to engage and hold the part properly. When replacing bolts, use only those having the same specifications of the original, or one which is equivalent.
2. Unless specific torque requirements are given within the text, standard torque values should be used on heat-treated bolts, studs, and steel nuts, in accordance with recommended shop practices. (See Torque Chart Section 1.)

Hydraulic Lines and Electrical Wiring

Clearly mark or tag hydraulic lines and electrical wiring, as well as their receptacles, when disconnecting or removing them from the unit. This will assure that they are correctly reinstalled.

Hydraulic System

1. Keep the system clean. If evidence of metal or rubber particles are found in the hydraulic system, drain and flush the entire system.
2. Disassemble and reassemble parts on clean work surface. Clean all metal parts with non-flammable cleaning solvent. Lubricate components, as required, to aid assembly.

Lubrication

Service applicable components with the amount, type, and grade of lubricant recommended in this manual, at the specified intervals. When recommended lubricants are not available, consult your local supplier for an equivalent that meets or exceeds the specifications listed.

Battery

Clean battery, using a non-metallic brush and a solution of baking soda and water. Rinse with clean water. After cleaning, thoroughly dry battery and coat terminals with an anti corrosion compound.

Lubrication and Servicing

Components and assemblies requiring lubrication and servicing are shown in the Lubrication Chart in Section 1.

2.3 LUBRICATION AND INFORMATION

Hydraulic System

1. The primary enemy of a hydraulic system is contamination. Contaminants enter the system by various means, e.g., using inadequate hydraulic oil, allowing moisture, grease, filings, sealing components, sand, etc., to enter when performing maintenance, or by permitting the pump to cavitate due to insufficient system warm-up or leaks in the pump supply (suction) lines.
2. The design and manufacturing tolerances of the component working parts are very close, therefore, even the smallest amount of dirt or foreign matter entering a system can cause wear or damage to the components and generally results in faulty operation. Every precaution must be taken to keep hydraulic oil clean, including reserve oil in storage. Hydraulic system filters should be checked, cleaned, and/or replaced as necessary, at the speci-

SECTION 2 - GENERAL

fied intervals required in the Lubrication Chart in Section 1. Always examine filters for evidence of metal particles.

3. Cloudy oils indicate a high moisture content which permits organic growth, resulting in oxidation or corrosion. If this condition occurs, the system must be drained, flushed, and refilled with clean oil.
4. It is not advisable to mix oils of different brands or types, as they may not contain the same required additives or be of comparable viscosities. Good grade mineral oils, with viscosities suited to the ambient temperatures in which the machine is operating, are recommended for use.

NOTE: Metal particles may appear in the oil or filters of new machines due to the wear-in of meshing components.

Hydraulic Oil

1. Refer to Section 1 for recommendations for viscosity ranges.
2. JLG recommends Mobil DTE-11 hydraulic oil, which has an SAE viscosity of 10W and a viscosity index of 140.

NOTE: Start-up of hydraulic system with oil temperatures below -20 degrees F (-29 degrees C) is not recommended. If it is necessary to start the system in a sub-zero environment, it will be necessary to heat the oil with a low density, 100VAC heater to a minimum temperature of -20 degrees F (-29 degrees C).

Changing Hydraulic Oil

1. Filter elements must be changed after the first 50 hours of operation and every 300 hours thereafter. If it is necessary to change the oil, use only those oils meeting or exceeding the specifications appearing in this manual. If unable to obtain the same type of oil supplied with the machine, consult local supplier for assistance in selecting the proper equivalent. Avoid mixing petroleum and synthetic base oils.
2. Use every precaution to keep the hydraulic oil clean. If the oil must be poured from the original container into another, be sure to clean all possible contaminants from the service container. Always clean the mesh element of the filter and replace the cartridge any time the system oil is changed.
3. While the unit is shut down, a good preventive maintenance measure is to make a thorough inspection of all hydraulic components, lines, fittings, etc., as well as a functional check of each system, before placing the machine back in service.

Lubrication Specifications

Specified lubricants, as recommended by the component manufacturers, are always the best choice, however, multi-purpose greases usually have the qualities which meet a variety of single purpose grease requirements. Should any question arise, regarding the use of greases in maintenance stock, consult your local supplier for evaluation. Refer to Section 1 for an explanation of the lubricant key designations appearing in the Lubrication Chart.

2.4 CYLINDER DRIFT TEST

Maximum acceptable cylinder drift is to be measured using the following methods.

Platform Drift

Measure the drift of the platform to the ground. Lower booms (if equipped) slightly elevated, upper boom fully extended with the rated load in the platform and power off. Maximum allowable drift is 2 inches (5 cm) in 10 minutes. If the machine does not pass this test, proceed with the following.

Cylinder Drift

Table 2-2. Cylinder Drift

Cylinder Bore Diameter		Max. Acceptable Drift in 10 Minutes	
inches	mm	inches	mm
3	76.2	0.026	0.66
3.5	89	0.019	0.48
4	101.6	0.015	0.38
5	127	0.009	0.22
6	152.4	0.006	0.15
7	177.8	0.005	0.13
8	203.2	0.0038	0.10
9	228.6	0.0030	0.08

Drift is to be measured at the cylinder rod with a calibrated dial indicator. The cylinder oil must be at ambient temperature and temperature stabilized.

The cylinder must have the normal load, which is the normal platform load applied.

If the cylinder passes this test, it is acceptable.

NOTE: This information is based on 6 drops per minute cylinder leakage.

2.5 PINS AND COMPOSITE BEARING REPAIR GUIDELINES

Filament wound bearings.

1. Pinned joints should be disassembled and inspected if the following occurs:
 - a. Excessive sloppiness in joints.
 - b. Noise originating from the joint during operation.
2. Filament wound bearings should be replaced if any of the following is observed:
 - a. Frayed or separated fibers on the liner surface.
 - b. Cracked or damaged liner backing.
 - c. Bearings that have moved or spun in their housing.
 - d. Debris embedded in liner surface.
3. Pins should be replaced if any of the following is observed (pin should be properly cleaned prior to inspection):
 - a. Detectable wear in the bearing area.
 - b. Flaking, peeling, scoring, or scratches on the pin surface.
 - c. Rusting of the pin in the bearing area.
4. Re-assembly of pinned joints using filament wound bearings.
 - a. Housing should be blown out to remove all dirt and debris...bearings and bearing housings must be free of all contamination.
 - b. Bearing / pins should be cleaned with a solvent to remove all grease and oil...filament wound bearing are a dry joint and should not be lubricated unless otherwise instructed (i.e. sheave pins).
 - c. Pins should be inspected to ensure it is free of burrs, nicks, and scratches which would damage the bearing during installation and operation.

2.6 WELDING ON JLG EQUIPMENT

NOTE: This instruction applies to repairs, or modifications to the machine and to welding performed from the machine on an external structure, or component,

Do the Following When Welding on JLG Equipment

- Disconnect the battery.
- Ground only to structure being welded.

Do NOT Do the Following When Welding on JLG Equipment

- Ground on frame and weld on any other area than the chassis.
- Ground on turntable and weld on any other area than the turntable.
- Ground on the platform/support and weld on any other area than the platform/support.
- Ground on a specific boom section and weld on any other area than that specific boom section.
- Allow pins, wear pads, wire ropes, bearings, gearing, seals, valves, electrical wiring, or hoses to be between the grounding position and the welded area.

CAUTION

FAILURE TO COMPLY WITH THE ABOVE REQUIREMENTS MAY RESULT IN COMPONENT DAMAGE (I.E. ELECTRONIC MODULES, SWING BEARING, COLLECTOR RING, BOOM WIRE ROPES ETC.)

SECTION 2 - GENERAL

Table 2-3. Inspection and Preventive Maintenance Schedule

AREA	INTERVAL					
	Pre-Start ¹ Inspection	Weekly Preventive Maintenance	Monthly Preventive Maintenance	Pre-Delivery ² or Frequent ³ Inspection	Annual ⁴ (Yearly) Inspection	Every 2 Years
Boom Assembly	9					
Boom Weldments				1,2,4	1,2,4	
Hose/Cable Carrier Installations				1,2,9,12	1,2,9,12	
Pivot Pins and Pin Retainers				1,2	1,2	
Sheaves, Sheave Pins				1,2	1,2	
Bearings				1,2	1,2	
Wear Pads				1,2	1,2	
Covers or Shields				1,2	1,2	
Extend/Retract Chain or Cable Systems				1,2,3	1,2,3	
Platform Assembly	9					
Platform	1,2				1,2	
Railing	1,2			1	1,2	
Gate			5	1	1,5	
Floor	1,2			1	1,2	
Rotator		9,5		15		
Lanyard Anchorage Point	2			1,2,10	1,2,10	
Turntable Assembly	9					
Swing Bearing or Worm Gear				1,2,14	1,2,3,13,14	
Oil Coupling		9				
Swing Drive System						
Turntable Lock				1,2,5	1,2,5	
Hood, Hood Props, Hood Latches				5	1,2,5	
Chassis Assembly	9					
Tires	1	16,17		16,17,18	16,17,18	
Wheel Nuts/Bolts	1	15		15	15	
Wheel Bearings						14,24
Oscillating Axle/Lockout Cylinder Systems					5,8	
Outrigger or Extendable Axle Systems				5,8	5,8	
Steer Components						
Drive Motors						
Torque Hubs				11	11	

Table 2-3. Inspection and Preventive Maintenance Schedule

AREA	INTERVAL					
	Pre-Start ¹ Inspection	Weekly Preventive Maintenance	Monthly Preventive Maintenance	Pre-Delivery ² or Frequent ³ Inspection	Annual ⁴ (Yearly) Inspection	Every 2 Years
Functions/Controls	9					
Platform Controls	5	5		6	6	
Ground Controls	5	5		6	6	
Function Control Locks, Guards, or Detents	1,5	1,5		5	5	
Footswitch	1,5			5	5	
Emergency Stop Switches (Ground & Platform)	5			5	5	
Function Limit or Cutout Switch Systems				5	5	
Capacity Indicator					5	
Drive Brakes				5		
Swing Brakes				5		
Boom Synchronization/Sequencing Systems					5	
Manual Descent or Auxiliary Power				5	5	
Power System	9					
Engine Idle, Throttle, and RPM	N/A					
Engine Fluids (Oil, Coolant, Fuel)	N/A					
Air/Fuel Filter		1,7		7	7	
Exhaust System			1,9	9	9	
Batteries	5	1,9			19	
Battery Fluid		11		11	11	
Battery Charger		5			5	
Fuel Reservoir, Cap, and Breather	N/A					
Hydraulic/Electric System	9					
Hydraulic Pumps		1,9		1,2,9		
Hydraulic Cylinders		1,9,7	2	1,2,9	1,2,9	
Cylinder Attachment Pins and Pin Retainers		1,9		1,2	1,2	
Hydraulic Hoses, Lines, and Fittings		1,9	12	1,2,9,12	1,2,9,12	
Hydraulic Reservoir, Cap, and Breather	11	1,9	2	1,5	1,5	24
Hydraulic Filter		1,9		7	7	
Hydraulic Fluid	11			7,11	7,11	
Electrical Connections		1		20	20	
Instruments, Gauges, Switches, Lights, Horn		1			5,23	
General						
Operators and Safety Manuals in Storage Box	21			21	21	
ANSI and EMI Manuals/Handbooks Installed					21	

SECTION 2 - GENERAL

Table 2-3. Inspection and Preventive Maintenance Schedule

AREA	INTERVAL					
	Pre-Start ¹ Inspection	Weekly Preventive Maintenance	Monthly Preventive Maintenance	Pre-Delivery ² or Frequent ³ Inspection	Annual ⁴ (Yearly) Inspection	Every 2 Years
Capacity Decals Installed, Secure, Legible	21			21	21	
All Decals/Placards Installed, Secure, Legible	21			21	21	
Walk-Around Inspection Performed	21					
Annual Machine Inspection Due				21		
No Unauthorized Modifications or Additions				21	21	
All Relevant Safety Publications Incorporated				21	21	
General Structural Condition and Welds				2,4	2,4	
All Fasteners, Pins, Shields, and Covers				1,2	1,2	
Grease and Lubricate to Specifications				22	22	
Function Test of All Systems	21			21	21, 22	
Paint and Appearance				7	7	
Stamp Inspection Date on Frame					22	
Notify JLG of Machine Ownership					22	

Footnotes:

¹ Prior to use each day; or at each Operator change

² Prior to each sale, lease, or delivery

³ In service for 3 months or 150 Hours; or Out of service for 3 months or more; or Purchased used

⁴ Annually, no later than 13 months from the date of the prior inspection

Performance Codes:

- 1 - Check for proper and secure installation
- 2 - Visual inspection for damage, cracks, distortion or excessive wear
- 3 - Check for proper adjustment
- 4 - Check for cracked or broken welds
- 5 - Operates Properly
- 6 - Returns to neutral or "off" position when released
- 7 - Clean and free of debris
- 8 - Interlocks function properly
- 9 - Check for signs of leakage
- 10 - Decals installed and legible
- 11 - Check for proper fluid level
- 12 - Check for chafing and proper routing
- 13 - Check for proper tolerances
- 14 - Properly lubricated
- 15 - Torqued to proper specification
- 16 - No gouges, excessive wear, or cords showing
- 17 - Properly inflated and seated around rim
- 18 - Proper and authorized components
- 19 - Fully charged
- 20 - No loose connections, corrosion, or abrasions
- 21 - Verify
- 22 - Perform
- 23 - Sealed Properly
- 24 - Drain, Clean, Refill

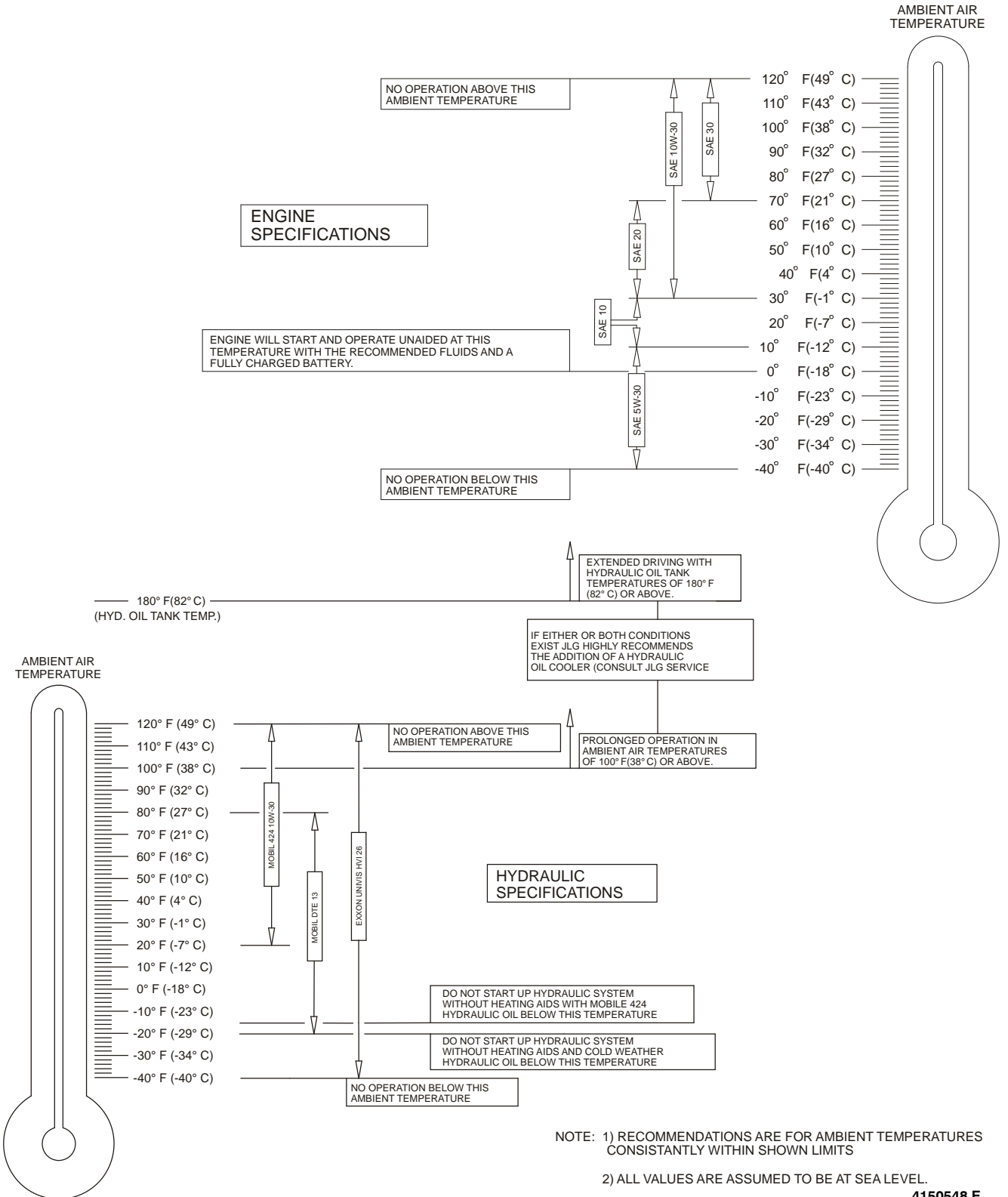

Figure 2-1. Engine Operating Temperature Specifications - Kubota

4150548 E

SECTION 3. CHASSIS & TURNTABLE

3.1 TIRES & WHEELS

Tire Inflation

The air pressure for pneumatic tires must be equal to the air pressure that is stenciled on the side of the JLG product or rim decal for safe and proper operational characteristics.

Tire Damage

For pneumatic tires, JLG Industries, Inc. recommends that when any cut, rip, or tear is discovered that exposes sidewall or tread area cords in the tire, measures must be taken to remove the JLG product from service immediately. Arrangements must be made for replacement of the tire or tire assembly.

For polyurethane foam filled tires, JLG Industries, Inc. recommends that when any of the following are discovered, measures must be taken to remove the JLG product from service immediately and arrangements must be made for replacement of the tire or tire assembly.

- a smooth, even cut through the cord plies which exceeds 3 inches (7.5 cm) in total length
- any tears or rips (ragged edges) in the cord plies which exceeds 1 inch (2.5 cm) in any direction
- any punctures which exceed 1 inch in diameter
- any damage to the bead area cords of the tire

If a tire is damaged but is within the above noted criteria, the tire must be inspected on a daily basis to insure the damage has not propagated beyond the allowable criteria.

Tire Replacement

JLG recommends a replacement tire be the same size, ply and brand as originally installed on the machine. Please refer to the JLG Parts Manual for the part number of the approved tires for a particular machine model. If not using a JLG approved replacement tire, we recommend that replacement tires have the following characteristics:

- Equal or greater ply/load rating and size of original
- Tire tread contact width equal or greater than original
- Wheel diameter, width, and offset dimensions equal to the original
- Approved for the application by the tire manufacturer (including inflation pressure and maximum tire load)

Unless specifically approved by JLG Industries Inc. do not replace a foam filled or ballast filled tire assembly with a pneumatic tire. When selecting and installing a replacement tire, ensure that all tires are inflated to the pressure recommended by JLG. Due to size variations between tire brands, both tires on the same axle should be the same.

Wheel Replacement

The rims installed on each product model have been designed for stability requirements which consist of track width, tire pressure, and load capacity. Size changes such as rim width, center piece location, larger or smaller diameter, etc., without written factory recommendations, may result in an unsafe condition regarding stability.

Wheel Installation

It is extremely important to apply and maintain proper wheel mounting torque.

⚠ WARNING

WHEEL NUTS MUST BE INSTALLED AND MAINTAINED AT THE PROPER TORQUE TO PREVENT LOOSE WHEELS, BROKEN STUDS, AND POSSIBLE DANGEROUS SEPARATION OF WHEEL FROM THE AXLE. BE SURE TO USE ONLY THE NUTS MATCHED TO THE CONE ANGLE OF THE WHEEL.

Tighten the lug nuts to the proper torque to prevent wheels from coming loose. Use a torque wrench to tighten the fasteners. If you do not have a torque wrench, tighten the fasteners with a lug wrench, then immediately have a service garage or dealer tighten the lug nuts to the proper torque. Over-tightening will result in breaking the studs or permanently deforming the mounting stud holes in the wheels. The proper procedure for attaching wheels is as follows:

1. Start all nuts by hand to prevent cross threading. DO NOT use a lubricant on threads or nuts.

2. Tighten nuts in the following sequence:

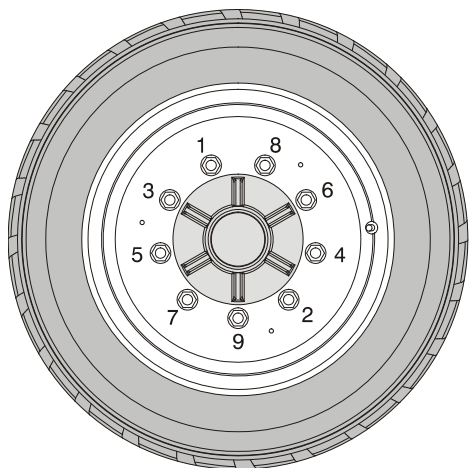

3. The tightening of the nuts should be done in stages. Following the recommended sequence, tighten nuts per wheel torque chart.

Table 3-1. Wheel Torque Chart

TORQUE SEQUENCE		
1st Stage	2nd Stage	3rd Stage
40 ft. lbs. (55 Nm)	100 ft. lbs. (130 Nm)	170 ft. lbs. (255 Nm)

4. Wheel nuts should be torqued after first 50 hours of operation and after each wheel removal. Check torque every 3 months or 150 hours of operation.

5. Check the unit for end play by moving the hub up & down parallel along the centerline of the spindle. If you can feel excessive end play (over the 0.010" [0.25 mm] specification), recheck the nut to see what is causing the excessive end play. Keep in mind that there can be some movement and still be within the 0.010" (0.25 mm) maximum specification. If there is no way of getting the excessive end play out by using your fingers, a socket or wrench may have to be used to set the end play.
6. The units should be checked visually to make sure the cotter pins are installed and that the correct components have been used. Each unit must also be checked for the proper feel to make sure there isn't excessive end play and the hubs turn freely.
7. Insert the dust cap and check to make sure the cotter pin is not going to interfere. Cap must be pressed all the way down. The unit should be checked again to assure it spins freely after the dust cap is installed.

Specifications

The end play specification is 0.001"/0.010" (0.025 / 0.254 mm) for all units.

Checking

The end play is checked by clamping the spindle in a fixture or vise and moving the hub parallel to the spindle centerline without rocking the hub. If the end play is set properly the following should apply:

1. Hub should rotate freely when spun by hand.
2. The hub should not be noticeably loose when moved parallel with spindle centerline.

3.2 SPINDLE

Setting Wheel Bearing End Play

NOTICE

BE SURE NOT TO OVER-TIGHTEN THE SPINDLE NUT.

1. Tighten the spindle nut to assure the bearings are properly seated.
2. Loosen the spindle nut completely until the nut can be turned by hand.
3. Tighten the spindle nut by hand using a socket without rotating the hub.
4. If the cotter pin can be assembled with the spindle nut finger tight, insert cotter pin without backing the nut off. If the cotter pin cannot be assembled with the spindle nut hand tight, tighten the spindle nut to the nearest available slot and insert cotter pin. If more than 1/2 of the cotter pin hole in the spindle can be seen in a slot, back nut off to nearest slot and insert pin.

Greasing Requirements

Hub assemblies shall have grease packed in the bearings via an appropriate greasing spindle or by hand. In either method, the bearing must be greased so the grease is forced thru the entire bearing cavity and thru the rollers of both inner and outer bearings.

Dust or grease caps used shall have grease applied to the inside of the cap.

The bearing cavity shall be filled 50 - 80% full of grease on all applications.

Dust or grease caps shall also be filled 10-20% full of grease on all applications prior to final assembly.

Visually verify that grease has flowed thru all rollers of the inner and outer bearings.

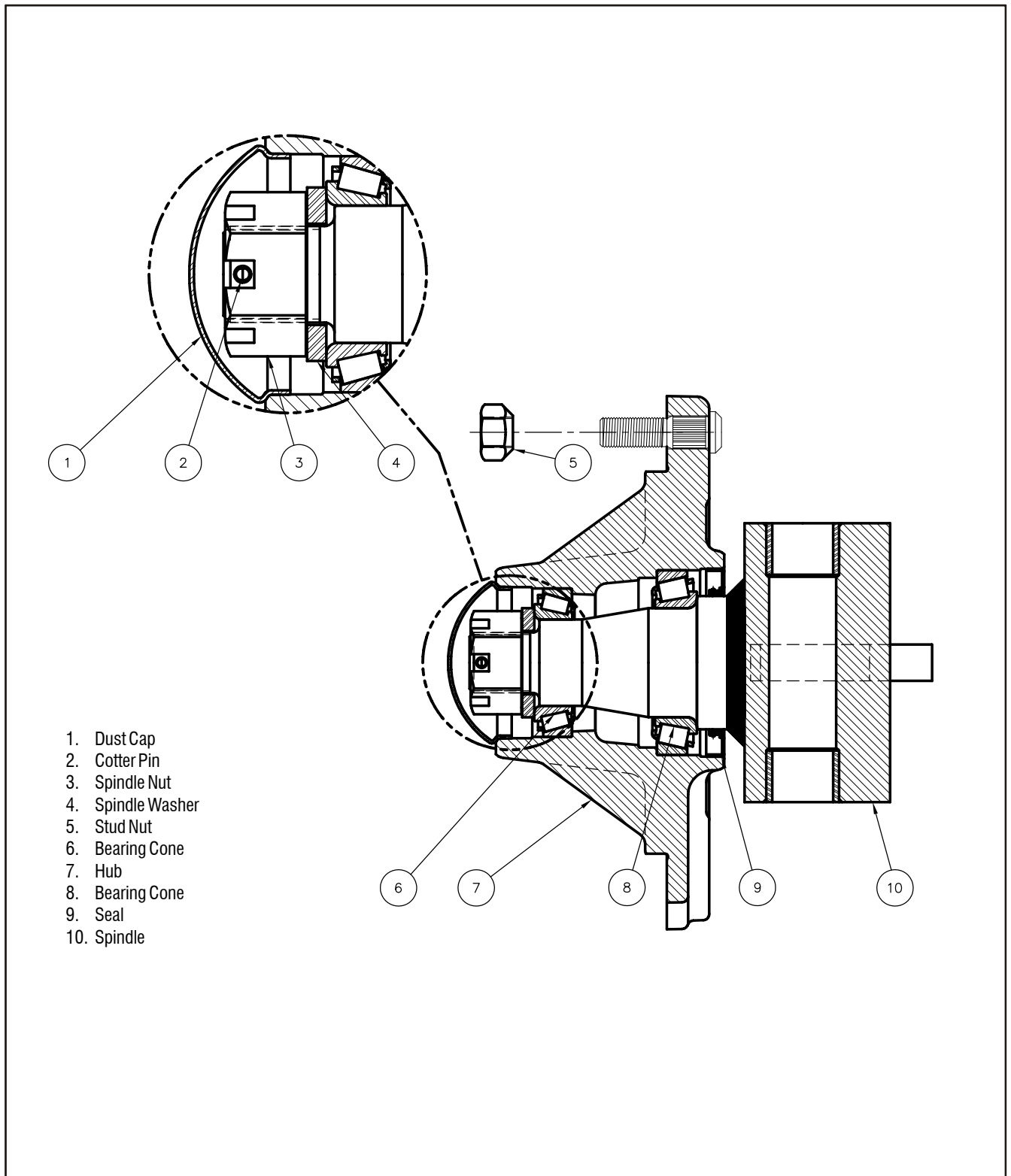

1. Dust Cap
2. Cotter Pin
3. Spindle Nut
4. Spindle Washer
5. Stud Nut
6. Bearing Cone
7. Hub
8. Bearing Cone
9. Seal
10. Spindle

Figure 3-3. Spindle Assembly

3.3 DRIVE HUB (PART NO. 2780236)

The final drive consists of two planetary stages with an integrated disconnect mechanism. Each stage incorporates a set of matched planetary gears, which provide an equal load distribution. All torque transmitting components are made of forged quenched and tempered high-alloy steels. External gears are carburized. Precision roller bearings support the sprocket or wheel loads. A shaft seal protects the unit against contamination.

Disassembling

1. Position drive so that one of the fill holes is at the bottom of the end cover and drain the oil.
 2. Remove all bolts holding the motor and Remove motor from drive.
 3. Compress the disc (59) using a simple fixture or other suitable device.
 4. Remove snap ring (66) and release pressure on disc until loose. Remove tool and disc.
 5. Remove the spring (55) from the input shaft (44).
 6. Turn unit so that cover (8) is in the up position.
 7. Remove the screw plugs (22) and seal rings (21).
 8. Remove snap rings (34), and remove the cover unit (8) from drive.
 9. Remove "o" ring (33).
 10. Remove the first stage planetary assembly (7).
 11. Remove hex bolts (23).
 12. Remove ring gear (30) and "o" ring (19).
 13. Remove snap rings (15).
 14. Pull off planet gears (1) together with cylindrical roller bearings (11) from spindle (60).
 15. Inspect the planetary stage assemblies as complete units. Thoroughly clean and check both the gearing and the bearings for damage and apply new oil. If the gears or bearings need replacing, they must be replaced as complete sets.
 16. The first stage planetary gears (2) **must be changed in sets of three pieces.**
 17. The first stage planetary gears (2) **must** be changed as a complete set of three and JLG recommends changing the sun gear shaft (43) along with this set of planets.
 18. The second stage planetary bearings (11) **must** be replaced in sets of four pieces.
 19. The second stage planetary gears (1) **must** be changed as a complete set of four and JLG recommends changing the sun gear (3) along with this set of planets.
- NOTE:** *Further disassembly of the hub is discouraged. reinstallation of the shaft nut (4) requires a special tool and a torque of 626 ft./ lbs. (876 Nm) for proper reassembly. These components Will Fail if not properly reassembled.*

Disassembly

1. Loosen and remove hex head bolts (53) to remove cover (51).
2. Remove shaft rod (56) and “o” ring (54).
3. Remove sleeve (52).

Disassembly of the first stage planetary assembly (7)

1. Push sun gear shaft (43) out of the first stage.
2. Remove snap rings (14).
3. Press planet pins (5) out of the planet gears (2).
4. Pull cylindrical roller bearing (10) out of the planet gears (2).
5. Remove snap ring (16) from sun gear (3) and Remove planet carrier (7) from sun gear (3).
6. Remove thrust washer (49).

Disassembly of second stage planet gears (1)

1. Press cylindrical roller bearings out of planet gears (1).

Assembly of first stage planetary assembly (7)

1. Pre-freeze planet pins (5) and install into planet carrier (7).
2. Install planet carrier (7) together with planet pins (5) on sun gear (3), and install snap ring (16).
3. Pre-heat thrust washer (49) and Install onto sun gear shaft (43).
4. Put sun gear shaft (43) into sun gear (3).
5. Pre-heat support disk (17) and install onto planet pins (5).
6. Pre-heat cylindrical roller bearings (10) and install onto planet pins (5) and fix bearings with snap rings (14).

Assembly of end cover unit (8)

1. Press sleeve (52) into cover (8).
2. Install “o” ring (54) into groove of cover (8).
3. Install shift rod (56) into cover (8).
4. Install the cover (51) into cover (8) and fix cover (51) with hex bolts (53). Tighten bolts with torque wrench to 6.3 ft. lbs. (8.5 Nm).

Final Assembly

1. Install thrust washer (29) in spindle (60).
2. Install "o" ring (19) into groove of support ring (6).
3. Install planet gears (1) onto planet pins which are part of spindle (60).
4. Install snap rings (15) on planet pins of spindle (60) in order to fix the planet gears (1).
5. Put ring gear (30) onto support ring (6) and fix ring gear (30) with hex head bolts (23). Tighten bolts with torque wrench to 15.5 ft. lbs.(21.1 Nm).
6. Insert the first stage planetary assembly (7) into drive.
7. Install "o" ring (33) in groove of ring gear (30).
8. Install end the cover unit (8) on shoulder ring gear (30) and fix with snap ring (34).
9. Install seal rings (22) and screw plugs (21).
10. Before installation of motor, CHECK THAT THERE IS 1-2mm OF CLEARANCE BETWEEN THE MOTOR SPLINE SHAFT SHOULDER AND THE COUPLER (62).
11. Install the motor and reconnect hydraulic lines.
12. Roll motor so that one fill plug is at 12 o'clock position, and the other is at 3 o'clock. Fill to bottom of 3 o'clock plug with gear oil. reinstall plugs

Initial Start-up And After Repairs

Before operating the machine, make sure that the drive is filled with clean oil, approximately 2 us gallons(.8 L). An accurate oil level is determined by the oil level plug, which should be removed before oil fill.

With the gear case filled to their proper levels, start the machine and allow sufficient time for run-in at moderate pressure and speed before running at full speed. After 4 hours of operation, recheck oil level.

Maintenance

Daily: - Check for oil leakage

Weekly: - Check oil level

Monthly: - Check mounting bolt torque

Oil Change Interval-Gear Drive

1. Perform the first oil change after approximately 150 hours.
2. Subsequent changes, every 1500 hours or annually, whichever occurs first.

NOTE: flush the drive before filling with new oil.

Setting of Tapered Roller Bearings

NOTE: The numbers in parentheses () reference the figure Drive Hub- Cutaway.

1. De-grease threads of the spindle (60) and shaft nut (4).
2. Spin the shaft nut onto spindle by hand to insure the threads are in good condition.
3. Apply Loctite 270 evenly to threads of the shaft nut.
4. Rotate the support ring repeatedly in one direction only, during setting of the tapered roller bearings.
5. Tighten shaft nut to 626 ft. lbs. (850 Nm).
6. Do not use the hub for 24 hours to allow the Loctite to harden properly.
7. Do not fill with oil for 24 hours to allow the Loctite to harden properly.

Securing of the Shaft Nut

1. After proper bearing setting is completed, use a suitable punch to place ball (24) 0.04 to 0.05 inches (1.1 to 1.3 mm) into the spindle thread. Then set ball (24) in position by punching in expander (25).

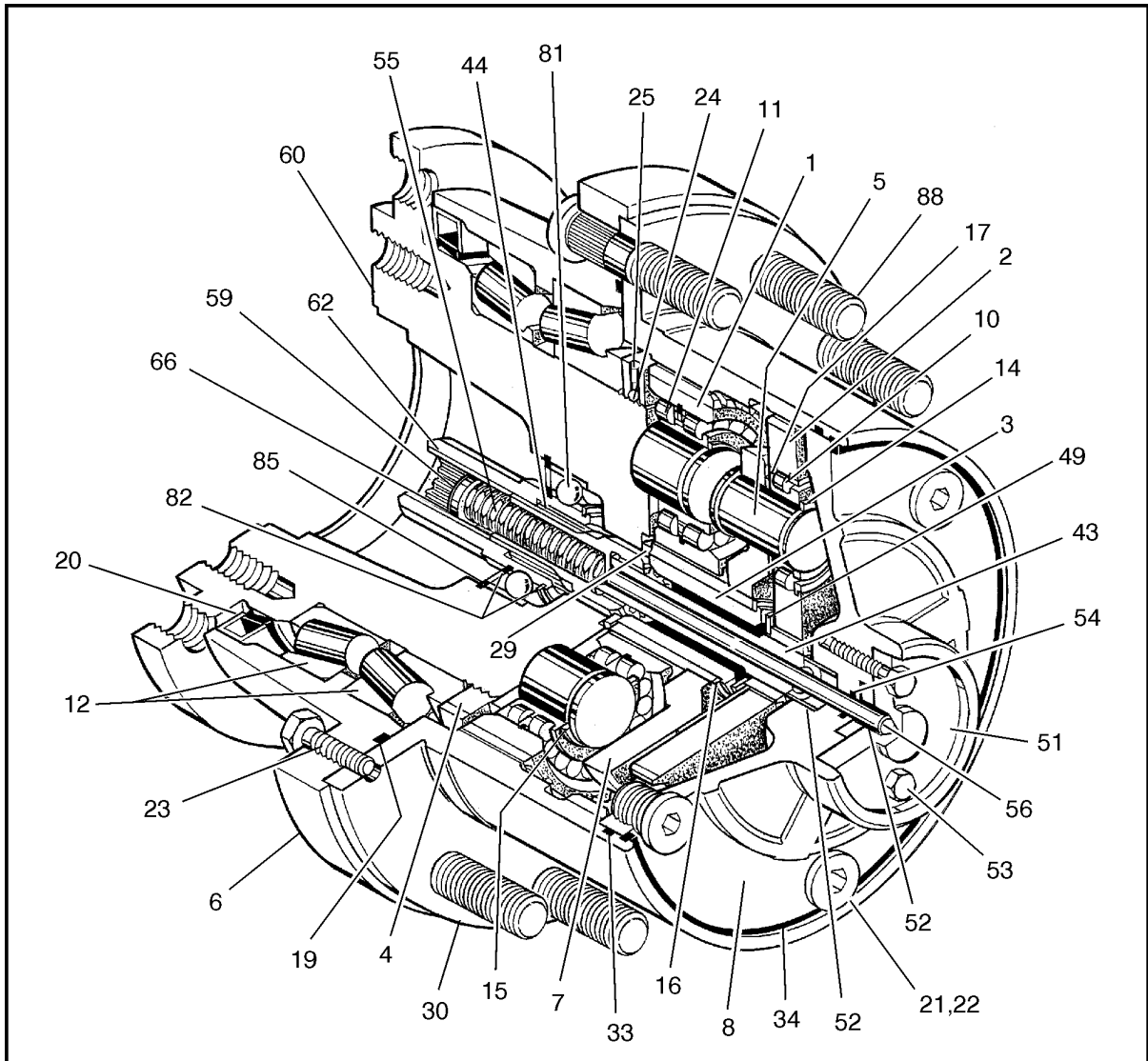

- | | | | |
|----------------------------|-------------------------|-------------------------|-------------------------|
| 1. Planet Gear | 15. Retaining Ring | 31. thru 32. (Not Used) | 56. Shaft Rod |
| 2. Planet Gear | 16. Retaining Ring | 33. O Ring | 57. thru 58. (Not Used) |
| 3. Sun Gear | 17. Support Disc | 34. Spring | 59. Rotor Disc |
| 4. Shaft Nut | 18. (Not Used) | 35. thru 42. (Not Used) | 60. Spindle |
| 5. Planet Bolt | 19. O Ring | 43. Sun Gear Shaft | 61. (Not Used) |
| 6. Support Ring | 20. Ring Seal | 44. Input Shaft | 62. Coupler |
| 7. Planet Carrier | 21. Screw Plug | 45. thru 48. (Not Used) | 63. thru 65. (Not Used) |
| 8. Cover | 22. Seal Ring | 49. Washer | 66. Retaining Ring |
| 9. (Not Used) | 23. Bolt | 50. (Not Used) | 67. thru 80. (Not Used) |
| 10. Roller Bearing | 24. Ball | 51. Cover | 81. Ball Bearing |
| 11. Roller Bearing | 25. Expander | 52. Disc | 82. Retaining Ring |
| 12. Tapered Roller Bearing | 26. thru 28. (Not Used) | 53. Bolt | 83. Retaining Ring |
| 13. (Not Used) | 29. Washer | 54. O Ring | 84. thru 87. (Not Used) |
| 14. Retaining Ring | 30. Ring Gear | 55. Pressure Spring | 88. Wheel Stud |

Figure 3-1. Drive Hub - Cutaway

3.4 DRIVE BRAKE - MICO

Disassembly

1. Remove pressure plate (3) from cover (21) by removing the capscrews (1) and washers (2).

⚠ CAUTION

PRESSURE PLATE IS UNDER SPRING TENSION OF APPROXIMATELY 1500 LBS (680 KGF). THE FOUR CAP SCREWS SHOULD BE LOOSENED EVENLY TO RELIEVE THIS FORCE. IF A HYDRAULIC PRESS IS AVAILABLE, 3000 LBS (1361 KGF) MINIMUM, THE PRESSURE PLATE CAN BE HELD IN POSITION WHILE REMOVING THE CAP SCREWS AND WASHERS

2. Remove case seal (4) from cover (21).
3. Remove piston (7) from pressure plate (3).
4. Remove o-ring (5), back-up ring (6), o-ring (8) and back-up ring (9) from piston (7).

NOTICE

IF THE SENSOR RING (12) IS DAMAGED OR NEEDS REPLACED, THE ENTIRE BRAKE MUST BE REPLACED AS A UNIT. THE SENSOR RING IS NOT AVAILABLE AS A SERVICE PART.

5. Remove stack assembly, consisting of stator disc (11), sensor ring (12), rotor disc (13), and plate (14) from cover (21).
6. Remove dowel pins (20), springs (15) and spring retainer (16) from cover (21).

NOTE: Note number and pattern of springs for reassembly purposes.

7. Remove retaining ring (17) from cover (21).
8. Remove shaft (10) by pressing or using a soft mallet on male end of the shaft.
9. Remove retaining ring (19) and bearing (18) from shaft (10).
10. Press rotary oil seal (20) from cover (18).

Assembly

NOTE: Lubricate all rubber components from the repair kit with clean type fluid used in the system.

1. Clean all parts thoroughly before assembly.
2. Press new rotary seal (22) into cover (21). **Note direction of seal**
3. Install new bearing (18) and retaining ring (19) on shaft (10).

4. Install shaft assembly and retaining ring (17) in cover (21).

NOTE: Be sure to use the same number of springs and spring pattern as recorded during disassembly. This should be five red springs evenly spaced.

5. Install dowel pins (20), spring retainer (16) and springs (5) in cover plate (21).
6. Position plate (14) on springs (15). **NOTE: Disc (13 & 11) and plate (14) must remain dry during installation. No oil residue must be allowed to contaminate disc surfaces.**
7. Place a new rotor disc (13), including speed sensor ring (12), on the shaft (10) until it contacts the plate (14). Install stator disc (11).
8. Install new o-ring (5), new back-up ring (6), new o-ring (8) and new back-up ring (9) on piston (7). Note order of o-rings and backup rings. Insert piston (7) into pressure plate (3). Be careful not to shear o-rings or back-up rings.
9. Install new case seal (4) in cover (21).
10. Position pressure plate (3) on cover (21) aligning dowel pins (20) with holes in pressure plate.

NOTE: A hydraulic press will simplify installation of pressure plate on cover. Clamp pressure plate in position while tightening the cap screws.

11. Install capscrews (1) and washers (2) and tighten evenly to draw pressure plate (3) to cover (21). Torque capscrews to 55 ft.lbs. (74.6 Nm).

⚠ CAUTION

IF HYDROSTATIC BENCH TESTING IS PERFORMED ON THE BRAKE ASSEMBLY, RELEASE PRESSURE SHOULD NOT EXCEED 2000 PSI (137.9 BAR) UNLESS TWO ADDITIONAL BOLTS ARE USED FOR SUPPLEMENTAL CLAMPING.

Bleeding

1. Install brake in system and connect pressure lines.
2. Bleed pressure release section of brake by pressurizing side inlet port and allowing air to escape from top port. Pressure should not exceed 100 psi (6.9 bar) during bleeding.
3. Apply sufficient pressure to release brake and check for proper operation in system.

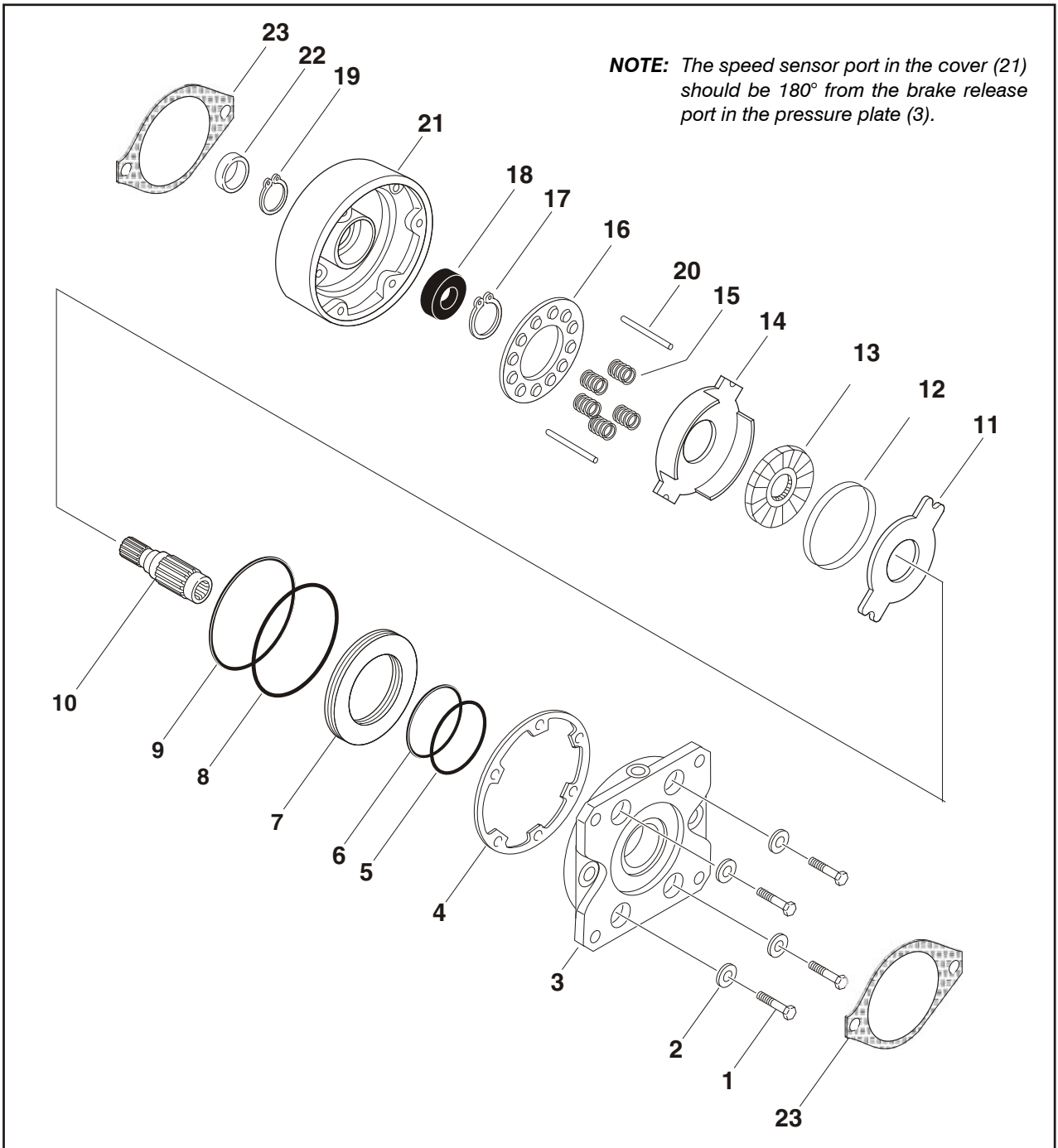

- | | | | |
|-------------------|-----------------|---------------------|---------------------|
| 1. Capscrew | 7. Piston | 13. Rotor Disc | 19. Retaining Ring |
| 2. Washer | 8. O-ring | 14. Plate | 20. Dowel Pin |
| 3. Pressure Plate | 9. Backup Ring | 15. Spring | 21. Cover |
| 4. Case Seal | 10. Shaft | 16. Spring Retainer | 22. Rotary Oil Seal |
| 5. O-ring | 11. Stator Disc | 17. Retaining Ring | 23. Gasket |
| 6. Backup Ring | 12. Sensor Ring | 18. Bearing | |

Figure 3-2. Drive Brake

SECTION 3 - CHASSIS & TURNTABLE

Table 3-2. Drive Brake Diagnosis

Problem	Cause	Explanation	Corrective Action
Brake slips	Excessive pressure In hydraulic system	If there is back pressure in the actuation line of the brake, holding torque will be reduced.	Check filters, hose size, restrictions in other hydraulic components.
	Oil In brake if designed for dry use	Wet linings generate 67% of the dry torque rating. If the brake has oil In it, check the type of oil hydraulic or gearbox. 1. Gearbox oil 2. Hydraulic oil	Replace oil seal in brake. Check motor seal. Check piston seals. Note: Internal components will need to be inspected, cleaned, and replaced as required.
	Springs broken or have taken a permanent set	Broken or set springs can cause reduced torque - rare occurrence.	See spring replacement
Brake drags or runs hot	Low actuation pressure	The brake should be pressurized to minimum of 1.38 bar (20 psi) over the full release pressure under normal operating conditions. Lower pressures will cause the brake to drag thus generating heat.	Place pressure gauge in bleed port & check pressure with system on.
	Bearing failure	If the bearing should fail, a large amount of drag can be generated.	Replace bearing.
Brake will not release	Stuck or clogged valve	Brakes are designed to come on when system pressure drops below stated release pressure. If pressure cannot get to brake, the brake will not release.	Place pressure gauge in bleed port - check for adequate pressure. Replace defective line or component.
	Bad o-rings	Release piston will not hold pressure, brake will not release.	Replace o-rings.
	Discs frozen	These brakes are designed for only limited dynamic braking. A severe emergency stop or prolonged reduced release pressure operation may result in this type of damage.	Replace disc stack.

3.5 SPEED SENSOR ADJUSTMENT

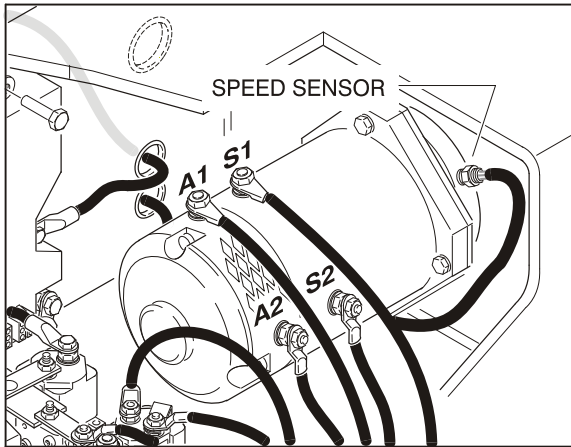

For proper drive operation, the speed sensors must be properly installed and adjusted. The sensor operates on a leading pulse to show direction. If installed wrong, the sensor will not be able to sense the proper direction.

⚠ WARNING

IF BOTH SPEED SENSORS ARE INSTALLED WRONG, THE CONTROLLER WILL THINK THE MACHINE IS ON A HILL AND WILL GO INTO FULL SPEED MODE IMMEDIATELY WHEN DRIVE IS SELECTED. THE MACHINE WILL NOT STOP UNLESS THE FOOT-SWITCH IS RELEASED OR THE EMS IS PUSHED IN.

IF ONLY ONE SENSOR IS INSTALLED WRONG, THE CONTROLLER SENSES A PROBLEM AND THE MACHINE WILL ONLY DRIVE AT CREEP SPEED. IF BOTH SENSORS ARE ADJUSTED TOO FAR OUT, THE CONTROL SYSTEM CONTROLLER WILL NOT DRIVE THE MACHINE.

Adjustment Procedure

1. Back off the locking nut and o-ring.
2. Thread the sensor in until it bottoms out (don't use excessive force).
3. Back-off 1-2 turns and align the notch with the axis of the brake. Refer to Figure 3-3., Speed Sensor Orientation.
4. Use a 1/2" wrench to hold the sensor and a 11/16" wrench to snug the lock nut to the brake.

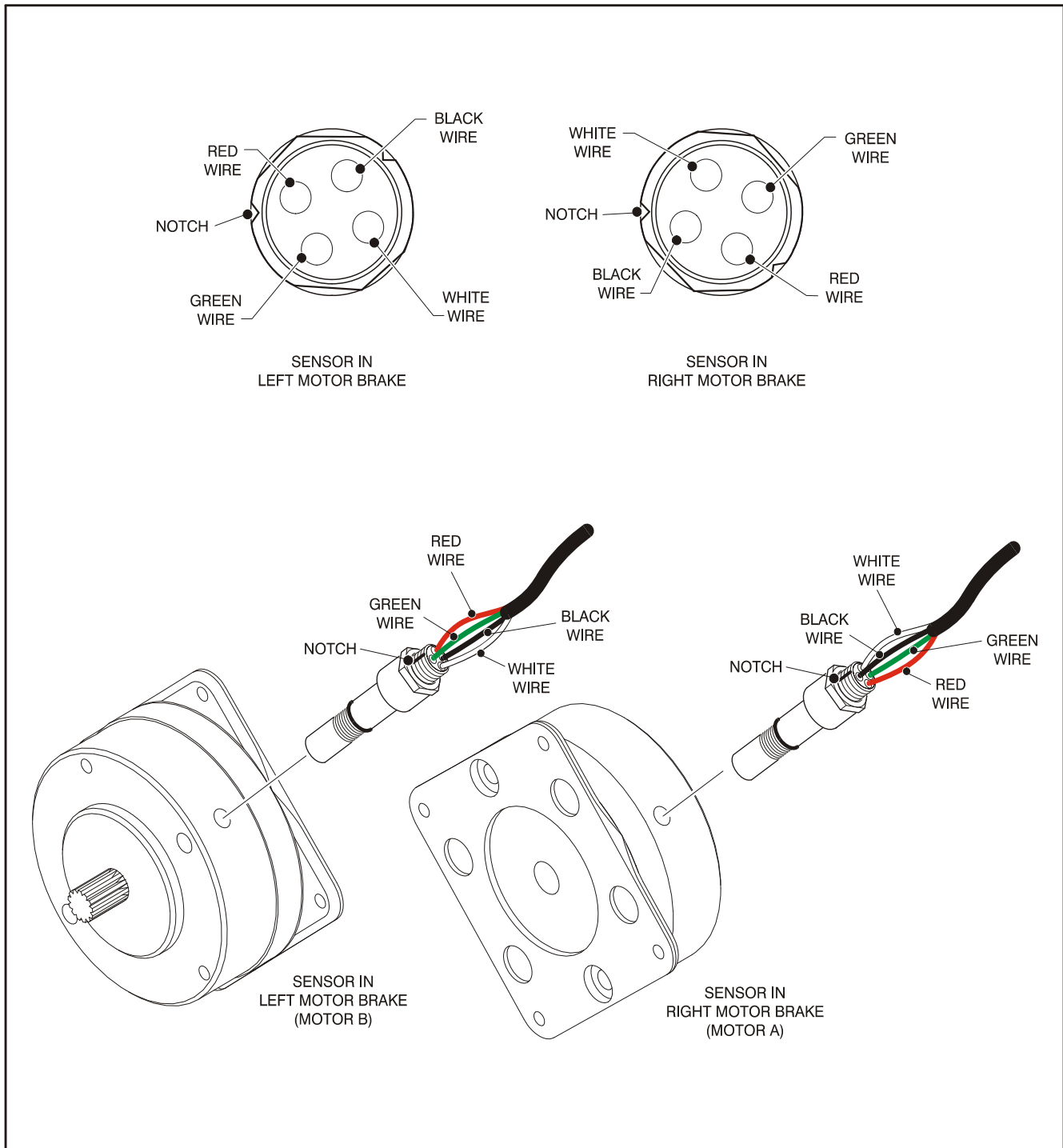

Figure 3-3. Speed Sensor Orientation

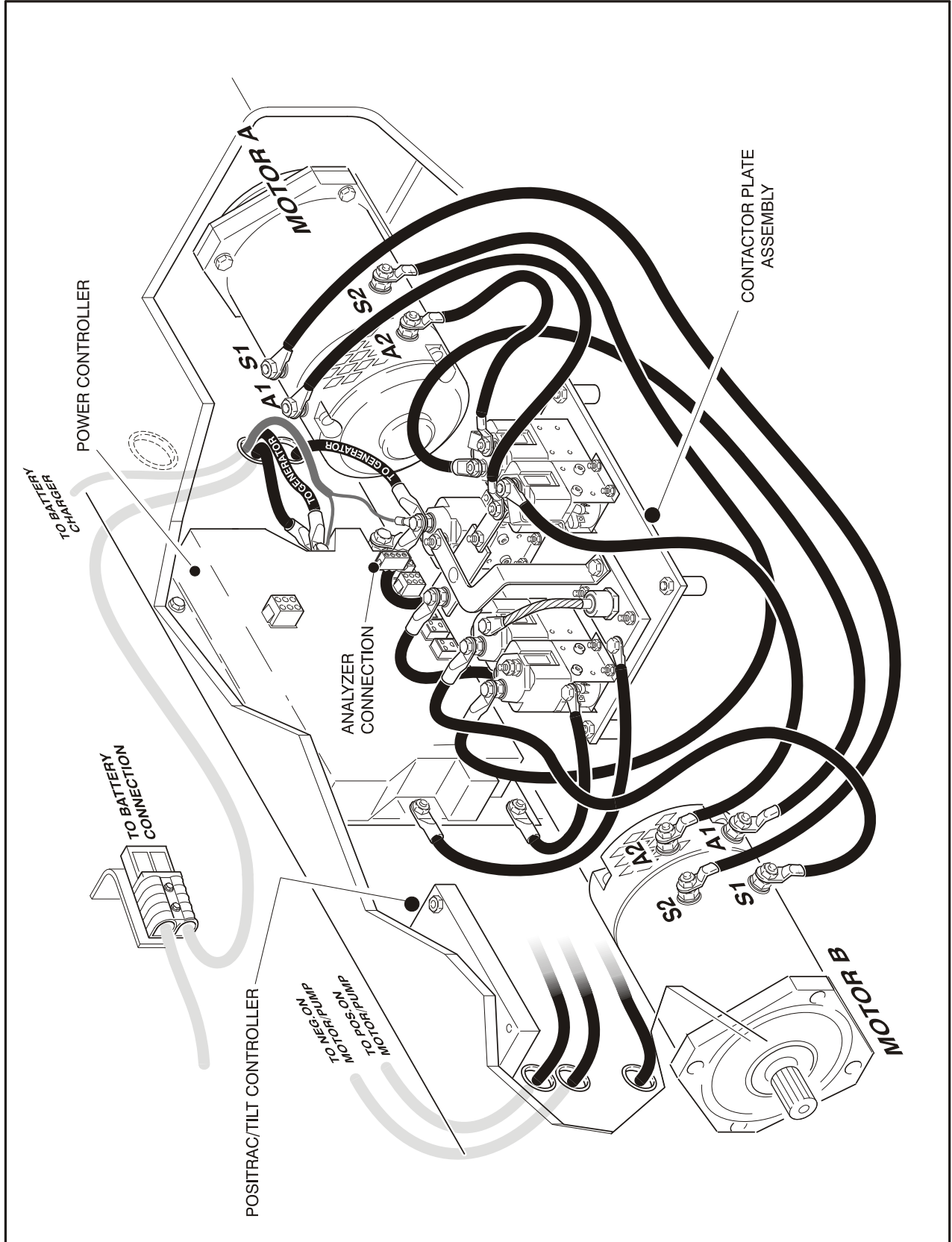
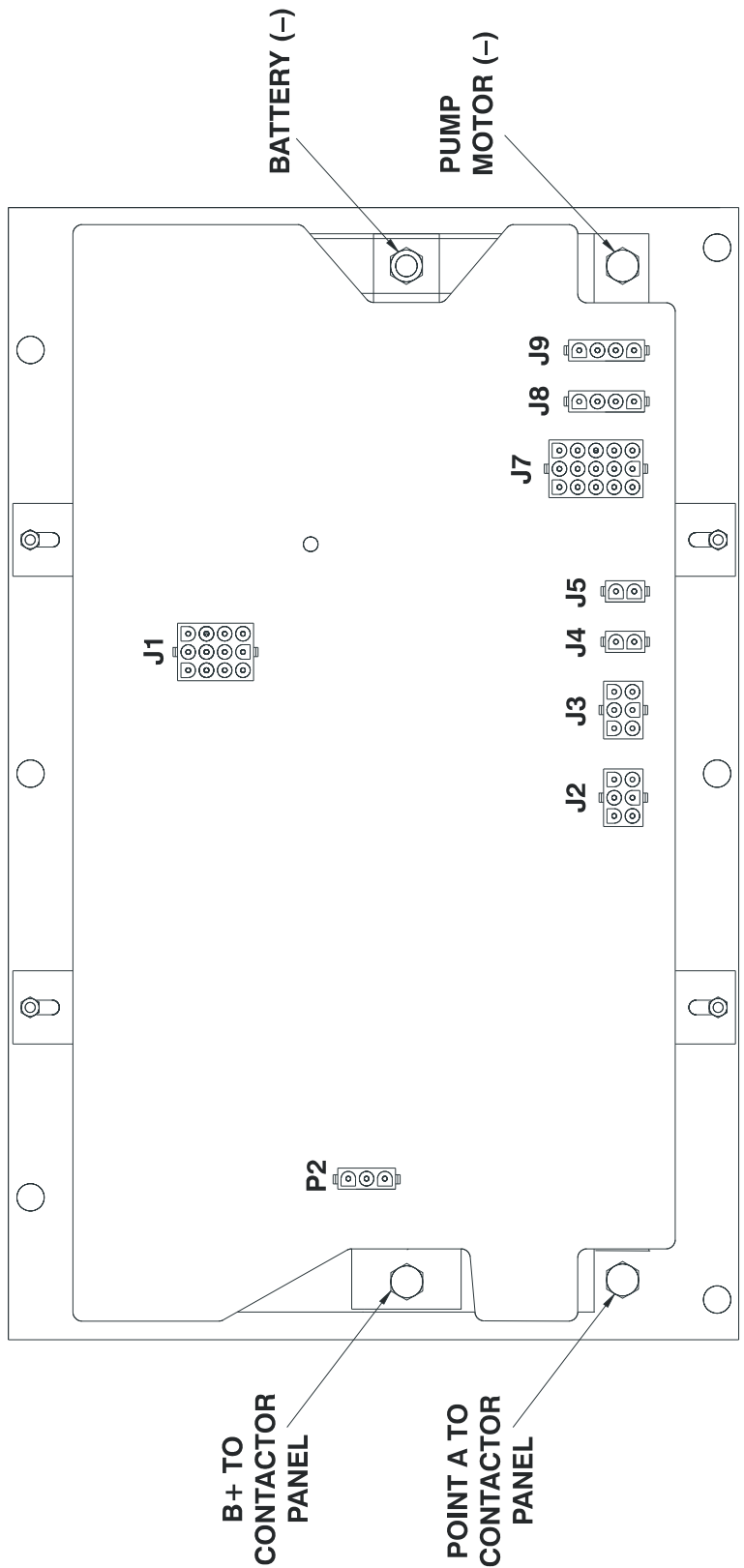

Figure 3-4. Frame Mounted Electrical Components - Sheet 1 of 2



TORQUE BRASS NUTS TO 80/IN.LBS.

1600292 - F

Figure 3-5. Frame Mounted Electrical Components - Sheet 2 of 2

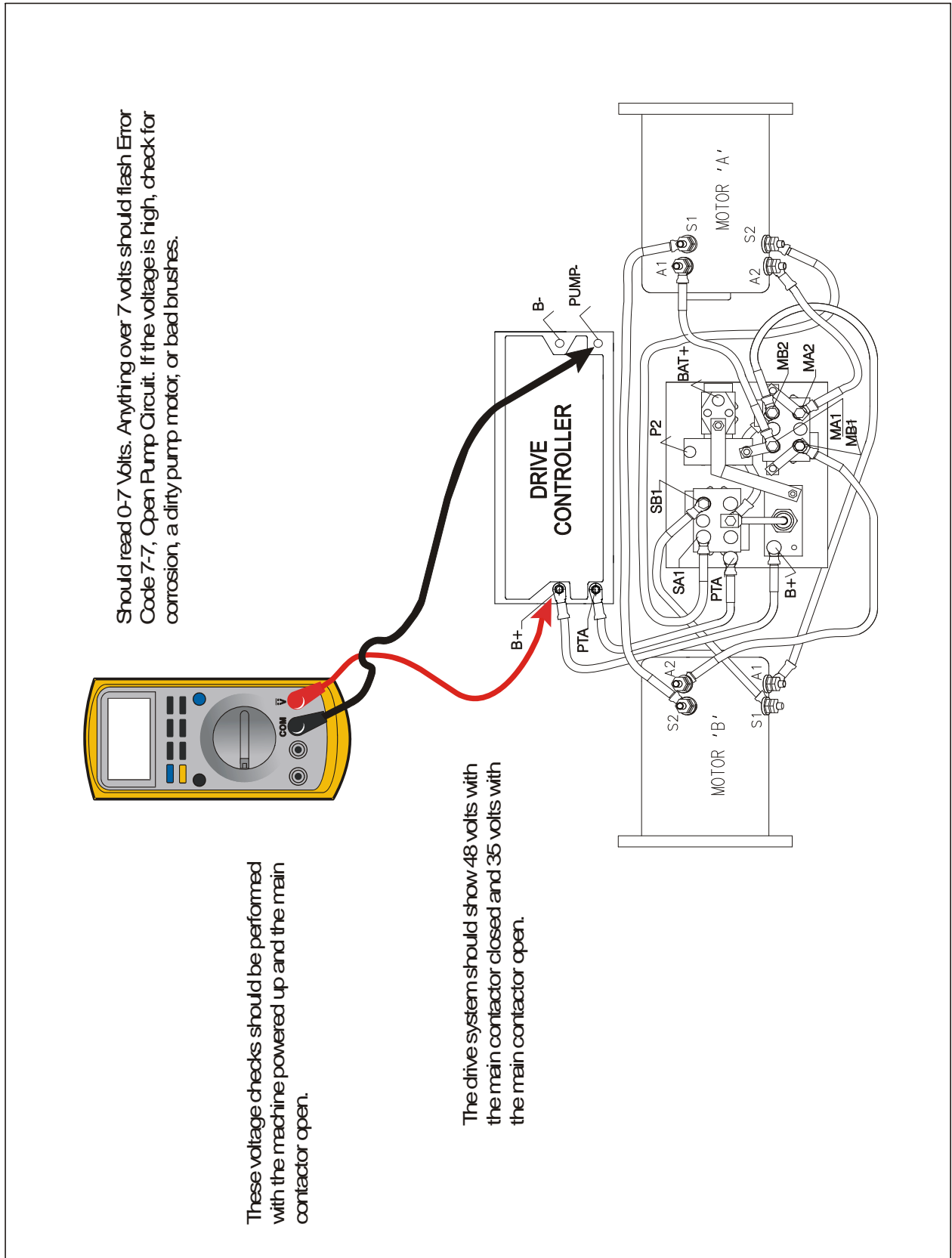

Figure 3-6. Voltage Checks

Speed Sensor Installation Verification

The motor controller averages the readings from the right and left speed sensors and therefore, it can be difficult to detect if the speed sensors are adjusted properly. When the positrac keeps coming in and out while on level surfaces, this is a sure indication that one of the speed sensors is not adjusted properly.

The worse case condition of speed sensor installation occurs when both sensors are installed in a manner that allows them to indicate the exact opposite direction that the machine is traveling. This situation causes the controller to believe that the machine is rolling in opposite direction than that selected by the operator. The controller's reaction to this situation is to put more power into the drive motors to attempt to overcome the fact that it believes the machine is rolling backwards. This presents itself as uncontrolled movement in the direction selected by the operator until the controller recognizes that it is placing maximum power in the motors and the controller and the speed sensors are still reporting movement in the opposite direction. The controller responds by shutting down drive and reporting flash code 5/5- Vehicle Runaway Check Speed Encoders.

If either speed sensor is disconnected or faulty, the controller will recognize this condition and immediately report flash code 5/5 - Left or Right speed Encoder Faulty.

Verification w/ Analyzer Procedure

Below is a procedure using the Analyzer that will verify that the speed sensors are installed correctly.

NOTICE

THIS PROCEDURE REQUIRES A LARGE SPACE CLEAR OF OBSTRUCTIONS. THE OPERATOR SHOULD BE FAMILIAR WITH JLG EQUIPMENT AND BE PREPARED TO USE THE FOOTSWITCH TO STOP THE MACHINE. READ AND UNDERSTAND THIS ENTIRE PROCEDURE PRIOR TO BEGINNING.

1. Before beginning this procedure, insure that there is at least 10 ft. (3m) in front and back of machine. Be sure that all other personnel stand clear of the machine during this procedure.
2. Unplug the left speed sensor from the posi-trac tilt module.
3. Power up the machine in platform mode and plug in the Analyzer in the platform.
4. Use the right and left cursor keys on the analyzer to highlight "DIAGNOSTICS" and press enter.
5. Use the right and left cursor keys on the analyzer to highlight "DRIVE" and press enter.
6. Use the right and left cursor keys to display "SPEED 0%" on the analyzer.
7. While watching the analyzer display, select drive forward. Be ready to remove your foot from the foot switch if the machine lunges forward.
8. The analyzer display should read the following if the RIGHT speed sensor is adjusted properly: "SPEED 20% FWD".
9. If the speed sensor is adjusted improperly, the analyzer will display "SPEED 20% REV" and the machine will lunge forward.
10. Adjust the right speed sensor using the preceding **Adjustment Procedure** until the analyzer displays "SPEED 20% FWD" when forward is selected at the platform. The percentage displayed is not critical, just the direction.
11. After obtaining the display in step 10, operate the machine in both forward and reverse directions. The machine should be controllable in both directions and will only drive at a maximum of creep speed. The display on the analyzer should match the direction selected.
12. After completing adjustment of the right sensor, plug the left sensor into the posi-tilt module.
13. Unplug the right sensor from the power module.
14. Power up the machine in platform mode and plug in the analyzer in the platform.
15. Use the right left cursor keys on the analyzer to highlight diagnostics and press enter.
16. Use the right and left cursor keys on the analyzer to highlight drive and press enter.
17. Use the right and left cursor keys to display "speed 0%" ON THE ANALYZER.

18. While watching the analyzer display, select drive forward. Be ready to remove your foot from the foot switch if the machine lunges forward.
19. The analyzer display should read the following if the left speed sensor is adjusted properly: "SPEED 20% FWD".
20. If the left speed sensor is adjusted improperly, the analyzer will display "SPEED 20% REV", and the machine will lunge forward.
21. Adjust the left speed sensor using the preceding **Adjustment Procedure** until the analyzer displays "SPEED 20% FWD" when forward is selected in the platform. The percentage displayed is not critical, just the direction.
22. After obtaining the display in step 10, operate the machine in both the forward and reverse directions. The machine should be controllable in both directions and will only drive at a maximum of creep speed. The display on the analyzer should match the direction selected.
23. Plug in the right sensor to the power module.
24. Test the machine. The machine should now have maximum drive speed available in both directions and should be controllable in both directions. The analyzer display should match the direction selected.

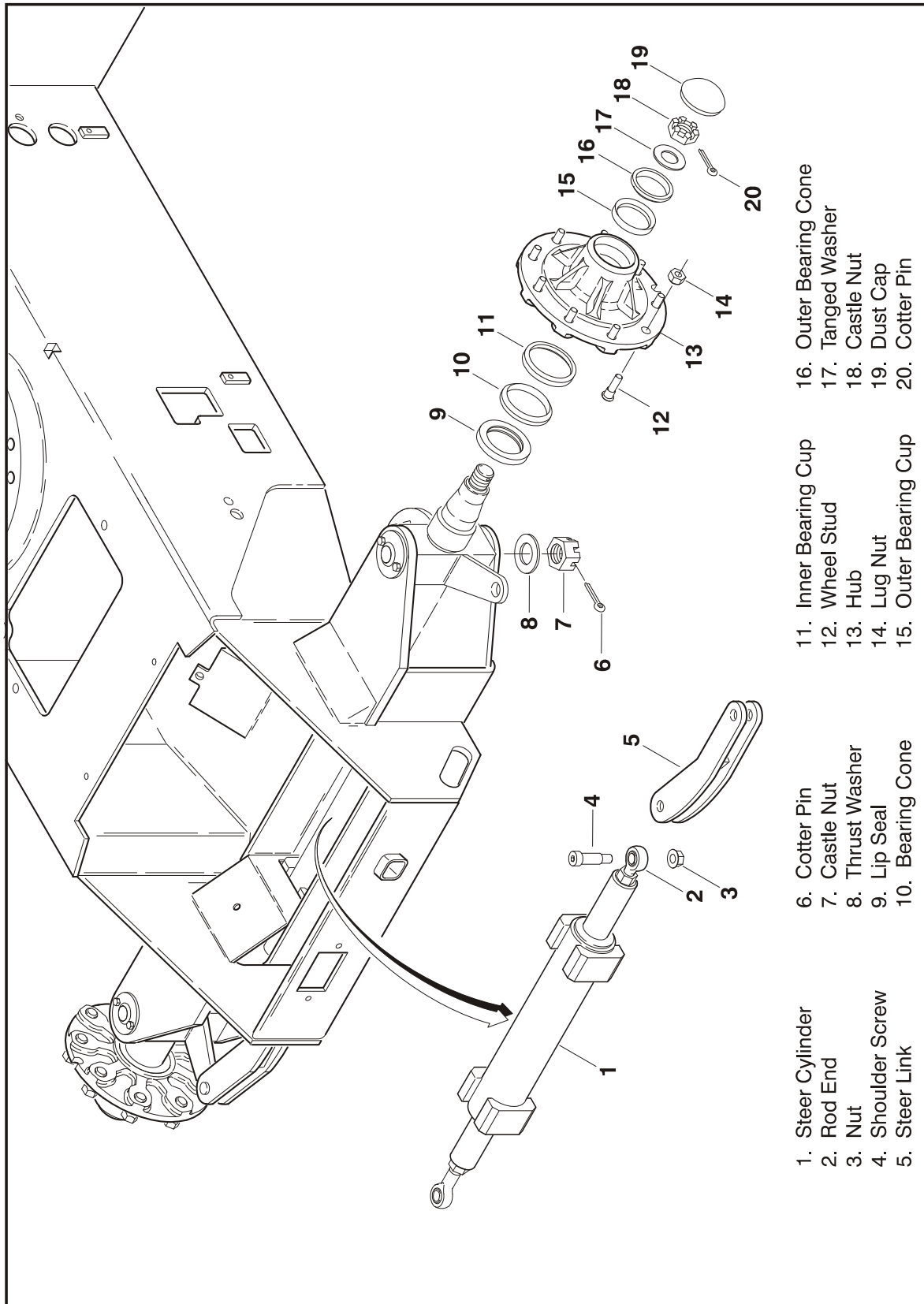

- | | | |
|-------------------|-----------------------|------------------------|
| 1. Steer Cylinder | 11. Inner Bearing Cup | 16. Outer Bearing Cone |
| 2. Rod End | 12. Wheel Stud | 17. Tanged Washer |
| 3. Nut | 13. Hub | 18. Castle Nut |
| 4. Shoulder Screw | 14. Lug Nut | 19. Dust Cap |
| 5. Steer Link | 15. Outer Bearing Cup | 20. Cotter Pin |

Figure 3-7. Steering Components and Spindles

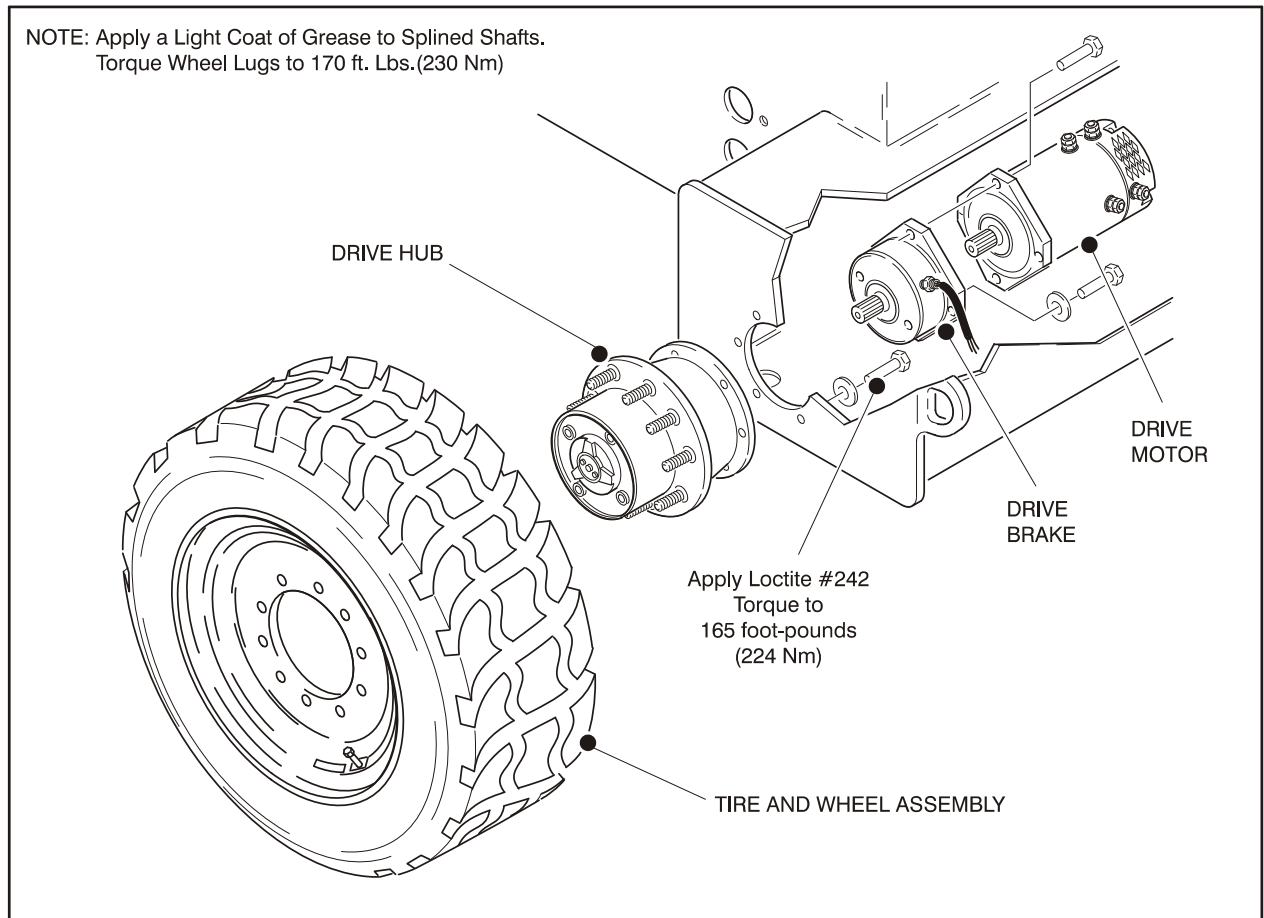

Figure 3-8. Drive Components

3.6 POSITRAC/TILT MODULE

When installing a new positrac/tilt module, always ensure that it is calibrated using the JLG Control System analyzer before operating the machine. Refer to JLG Control System Analyzer Kit instructions. Use a standard bubble level in two different directions to ensure that the machine's frame is level prior to installing the new positrac/tilt module.

1. Place the machine on a flat, level surface. Check for level by placing a bubble level on the frame in both directions.
2. Plug in the analyzer (Analyzer - p/n 1600244, Cable - p/n 1600633) into port J9 on the power module or port J1 on the platform module.
3. Use the right arrow key to curse over to "ACCESS LEVEL 2". Depress Enter.
4. Use Up/Down arrow keys to enter the following password "33271". Depress Enter.

5. Use the right arrow key to curse over to "LEVEL VEHICLE". Depress Enter. Depress Enter again.
6. Verify that the tilt reading is now "0.0; 0.0".

⚠ WARNING

TO ASSURE PROPER OPERATION, THE MACHINE MUST BE LEVEL WHEN INSTALLING AND CALIBRATING A NEW POSITRAC/TILT MODULE.

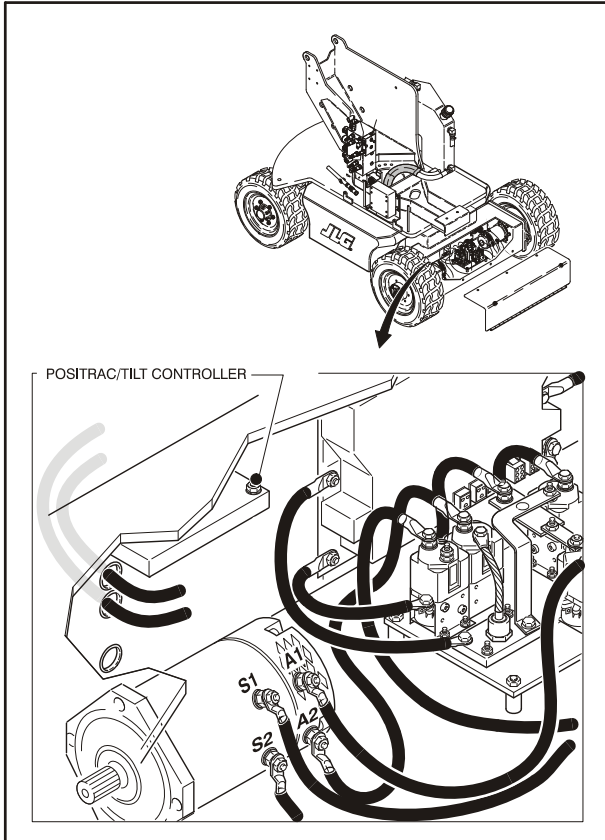

Figure 3-9. Tilt Sensor Location

3.7 SWING MOTOR - S/N 0300135649 TO PRESENT

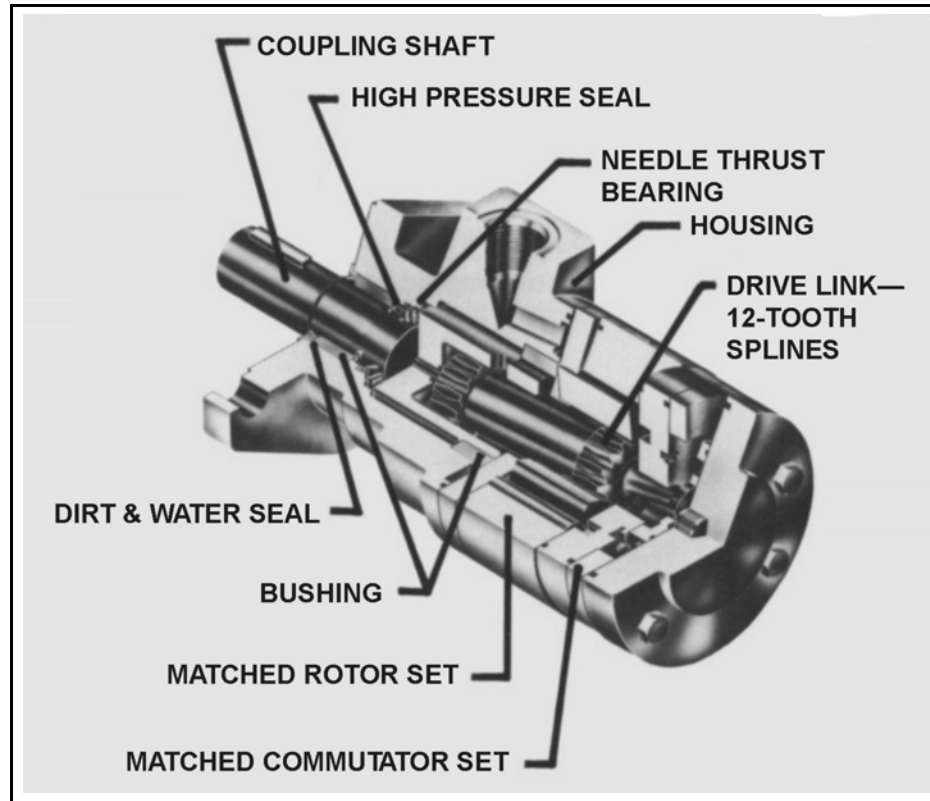

Figure 3-10. Swing Motor - Cutaway

⚠ CAUTION

IF THE HYDRAULIC SYSTEM FLUID BECOMES OVERHEATED [IN EXCESS OF 200°F (93.3°C)], SEALS IN THE SYSTEM CAN SHRINK, HARDEN OR CRACK, THUS LOSING THEIR SEALING ABILITY.

SECTION 3 - CHASSIS & TURNTABLE

Table 3-3. Swing Motor Troubleshooting

Trouble	Cause	Remedy
Oil Leakage	<ol style="list-style-type: none"> 1. Hose fittings loose, worn or damaged. 2. Oil seal rings (4) deteriorated by excess heat. 3. Special bolt (1, 1 A, 1B or 1C) loose or its sealing area deteriorated by corrosion. 4. Internal shaft seal (16) worn or damaged. 5. Worn coupling shaft (12) and internal seal (16). 	<p>Check & replace damaged fittings or "O" Rings. Torque to manufacturers specifications.</p> <p>Replace oil seal rings by disassembling unit.</p> <p>(a) Loosen then tighten single bolt to torque specification. (b) Replace bolt.</p> <p>Replace seal. Disassembly of motor unit necessary.</p> <p>Replace coupling shaft and seal by disassembling unit.</p>
Significant loss of speed under load	<ol style="list-style-type: none"> 1. Lack of sufficient oil supply 2. High internal motor leakage 3. Severely worn or damaged internal splines. 4. Excessive heat. 	<p>(a) Check for faulty relief valve and adjust or replace as required. (b) Check for and repair worn pump. (c) Check for and use correct oil for temperature of operation.</p> <p>Replace worn rotor set by disassembling unit.</p> <p>Replace rotor set, drive link and coupling shaft by disassembling unit.</p> <p>Locate excessive heat source (usually a restriction) in the system and correct the condition.</p>
Low mechanical efficiency or undue high pressure required to operate unit	<ol style="list-style-type: none"> 1. Line blockage 2. Internal interference 3. Lack of pumping pressure 4. Excessive binding or loading in system external to motor unit. 	<p>Locate blockage source and repair or replace.</p> <p>Disassemble unit, identify and remedy cause and repair, replacing parts as necessary.</p> <p>Check for and repair worn pump.</p> <p>Locate source and eliminate cause.</p>

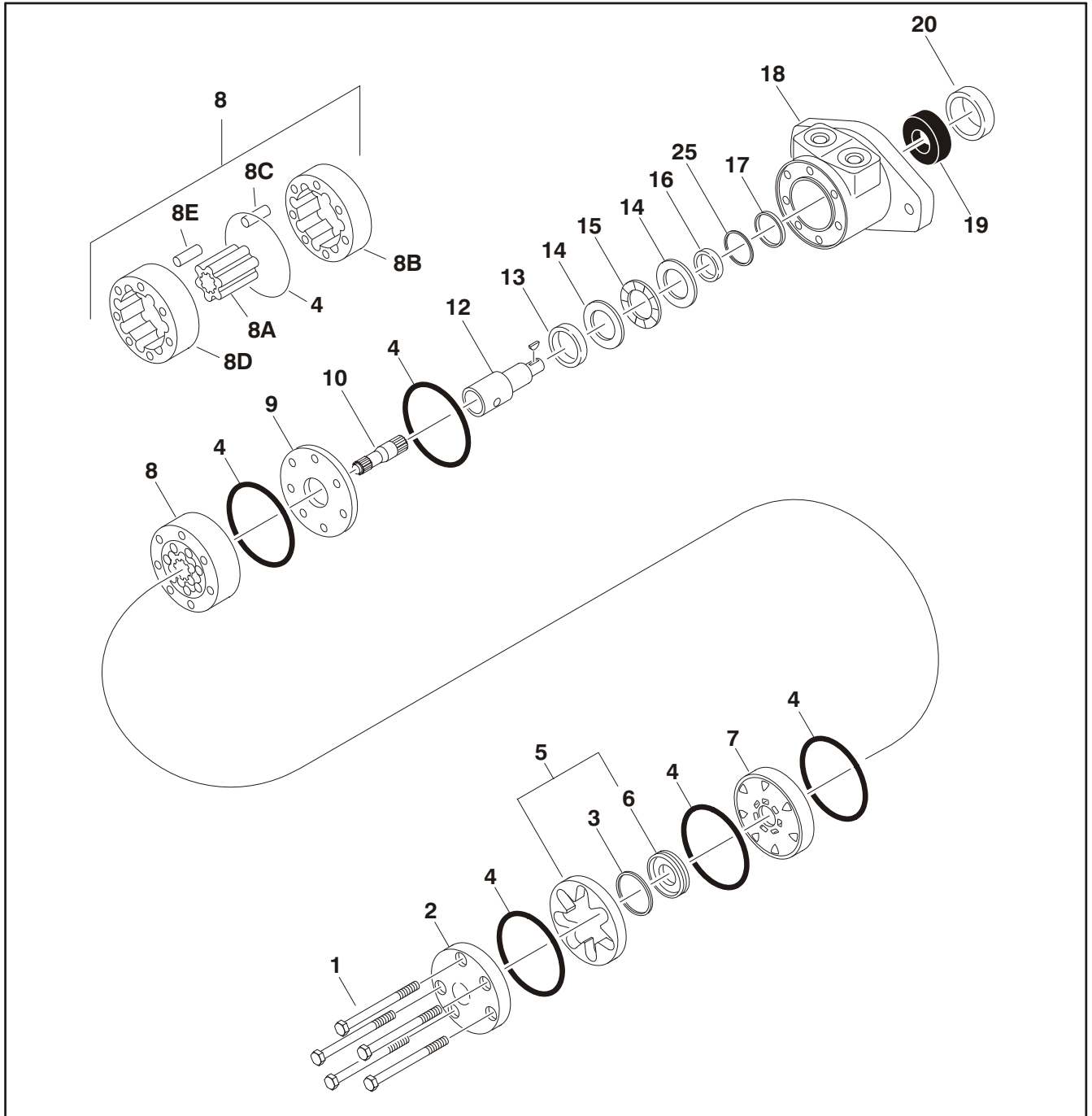

- | | | | | | |
|---------------|--------------------|--------------------|--------------------|-----------------------|-------------------|
| 1. Bolt | 6. Commutator Ring | 8C. Stator Vane | 12. Coupling Shaft | 17. Backup Ring | 22. Not Used |
| 2. End Cover | 7. Manifold | 8D. Stator Half | 13. Inner Bushing | 18. Housing | 23. Not Used |
| 3. Seal Ring | 8. Rotor Set | 9. Wear Plate | 14. Thrust Washer | 19. Outer Bushing | 24. Not Used |
| 4. Seal Ring | 8A. Rotor | 10. Drive Link | 15. Thrust Bearing | 20. Dirt & Water Seal | 25. Backup Washer |
| 5. Commutator | 8B. Stator Half | 11. Thrust Bearing | 16. Seal | 21. Not Used | |

Figure 3-11. Swing Motor - Exploded View

Preparation Before Disassembly

- Before you disassemble the motor unit or any of its components read this entire section. It provides important information on parts and procedures you will need to know to service the motor.
- Thoroughly clean off all outside dirt, especially from around fittings and hose connections, before disconnecting and removing the motor. Remove rust or corrosion from coupling shaft.
- Remove coupling shaft connections and hose fittings and immediately plug port holes and fluid lines.
- Remove the motor from system, drain it of fluid and take it to a clean work surface.
- Clean and dry the motor before you start to disassemble the unit.
- As you disassemble the motor clean all parts, except seals, in clean petroleum-based solvent, and blow them dry.

⚠ WARNING

PETROLEUM-BASE SOLVENTS ARE FLAMMABLE. BE EXTREMELY CAREFUL WHEN USING ANY SOLVENT. EVEN A SMALL EXPLOSION OR FIRE COULD CAUSE INJURY OR DEATH.

⚠ WARNING

WEAR EYE PROTECTION AND BE SURE TO COMPLY WITH OSHA OR OTHER MAXIMUM AIR PRESSURE REQUIREMENTS.

⚠ CAUTION

NEVER STEAM OR HIGH PRESSURE WASH HYDRAULIC COMPONENTS. DO NOT FORCE OR ABUSE CLOSELY FITTED PARTS.

- Keep parts separate to avoid nicks and burrs.
- Discard all seals and seal rings as they are removed from the motor. Replace all seals, seal rings and any damaged or worn parts with OEM approved service parts.

Disassembly and Inspection

1. Place the motor in a soft jawed vice, with coupling shaft (12) pointed down and the vise jaws clamping firmly on the sides of the housing (18) mounting flange or port bosses. Remove manifold port O-Rings if applicable.

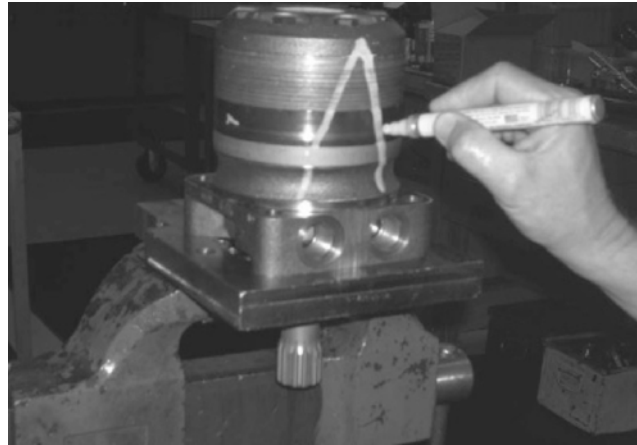

⚠ WARNING

IF THE MOTOR IS NOT FIRMLY HELD IN THE VISE, IT COULD BE DISLODGED DURING THE SERVICE PROCEDURES, CAUSING INJURY.

2. Scribe an alignment mark down and across the motor components from end cover (2) to housing (18) to facilitate reassembly orientation where required.

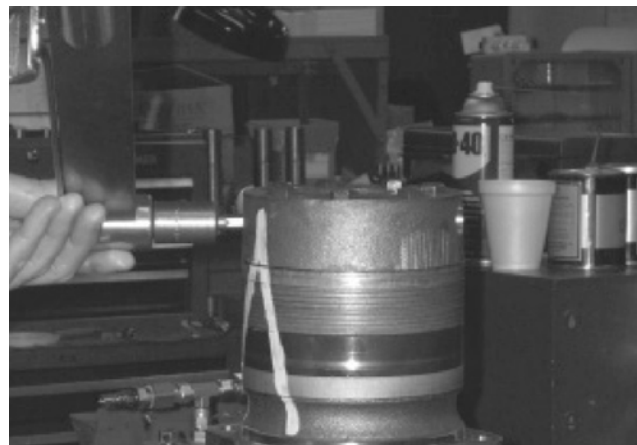

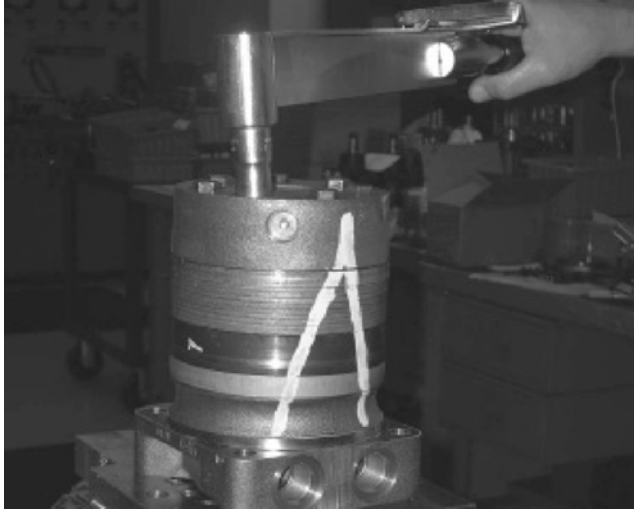

3. Remove the special ring head bolts (1) using an appropriate 1/2 or 9/16 inch size socket. Inspect bolts for damaged threads, or sealing rings, under the bolt head. Replace damaged bolts.



4. Remove end cover assembly (2) and seal ring (4). Discard seal ring.



5. Thoroughly wash end cover (2) in proper solvent and blow dry. Be sure the end cover valve apertures are free of contamination. Inspect end cover for cracks and the bolt head recesses for good bolt head sealing surfaces. Replace end cover as necessary.

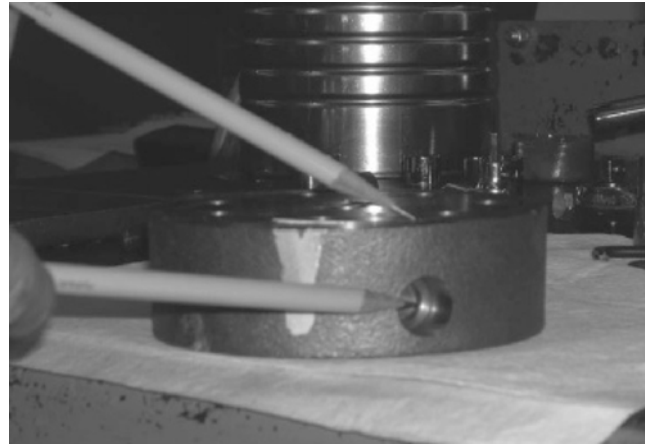

NOTE: A polished pattern (not scratches) on the cover from rotation of the commutator (5) is normal. Discoloration would indicate excess fluid temperature, thermal shock, or excess speed and require system investigation for cause and close inspection of end cover, commutator, manifold, and rotor set.

6. Remove commutator ring (6). Inspect commutator ring for cracks, or burrs.



SECTION 3 - CHASSIS & TURNTABLE

7. Remove commutator (5) and seal ring (3) Remove seal ring from commutator, using an air hose to blow air into ring groove until seal ring is lifted out and discard seal ring. Inspect commutator for cracks or burrs, wear, scoring, spalling or brinelling. If any of these conditions exist, replace commutator and commutator ring as a matched set.



8. Remove manifold (7) and inspect for cracks surface scoring, brinelling or spalling. Replace manifold if any of these conditions exist. A polished pattern on the ground surface from commutator or rotor rotation is normal. Remove and discard the seal rings (4) that are on both sides of the manifold.



NOTE: The manifold is constructed of plates bonded together to form an integral component not subject to further disassembly for service. Compare configuration of both sides of the manifold to ensure that same surface is reassembled against the rotor set.

9. Remove rotor set (8) and wearplate (9), together to retain the rotor set in its assembled form, maintaining the same rotor vane to stator contact surfaces. The drive link (10) may come away from the coupling shaft (12) with the rotor set, and wearplate. You may have to shift the rotor set on the wearplate to work the drive link out of the rotor and wearplate. Inspect the rotor set in its assembled form for nicks, scoring, or spalling on any surface and for broken or worn splines. If the rotor set component requires replacement, the complete rotor set must be replaced as it is a matched set. Inspect the wearplate for cracks, brinelling, or scoring. Discard seal ring (4) that is between the rotor set and wearplate.



NOTE: The rotor set (8) components may become disassembled during service procedures. Marking the surface of the rotor and stator that is facing UP, with etching ink or grease pencil before removal will ensure correct reassembly of rotor into stator and rotor set into motor. Marking all rotor components and mating spline components for exact repositioning at assembly will ensure maximum wear life and performance of rotor set and motor.

NOTE: A polished pattern on the wear plate from rotor rotation is normal.

10. Place rotor set (8) and wear plate (9) on a flat surface and center rotor in stator such that two rotor lobes (180 degrees apart) and a roller vane centerline are on the same stator centerline. Check the rotor lobe to roller vane clearance with a feeler gage at this common centerline. If there is more than 0.005 inches (0.13 mm) of clearance, replace rotor set.

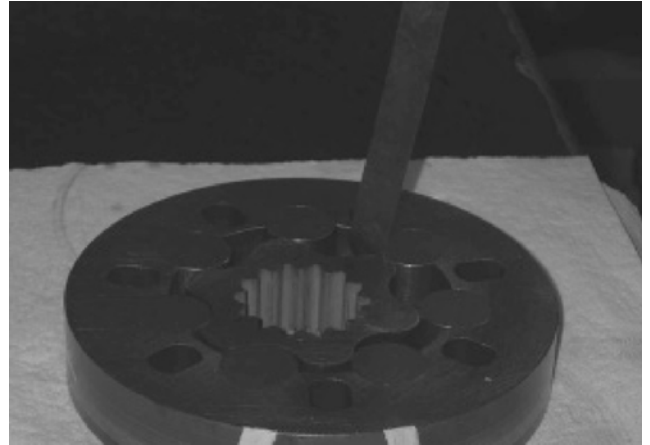

NOTE: If rotor set (8) has two stator halves and two sets of seven vanes as shown, check the rotor lobe to roller vane clearance at both ends of rotor.

11. Remove drive link (10) from coupling shaft (12) if it was not removed with rotor set and wear plate. Inspect drive link for cracks and worn or damaged splines. No perceptible lash (play) should be noted between mating spline parts. Remove and discard seal ring (4) from housing (18).



SECTION 3 - CHASSIS & TURNTABLE

12. Check exposed portion of coupling shaft (12) to be sure you have removed all signs of rust and corrosion which might prevent its withdrawal through the seal and bearing. Crocus cloth or fine emery paper may be used.

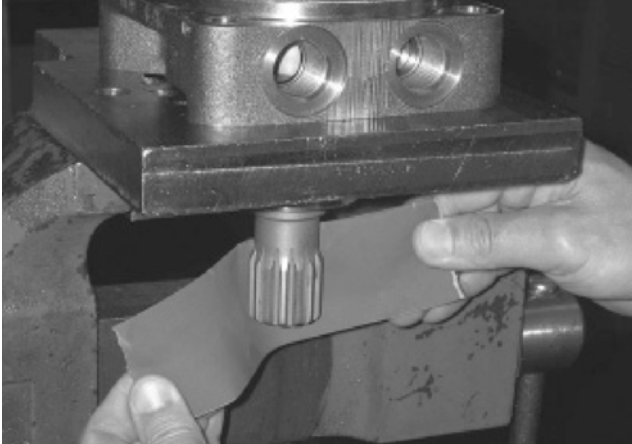

13. Remove coupling shaft (12), by pushing on the output end of shaft. Inspect coupling shaft bearing and seal surfaces for spalling, nicks, grooves, severe wear or corrosion and discoloration. Inspect for damaged or worn internal and external splines or

keyway. Replace coupling shaft if any of these conditions exist.



NOTE: Minor shaft wear in seal area is permissible. If wear exceeds 0.020 inches (0.51 mm) diametrically, replace coupling shaft.

NOTE: A slight "polish" is permissible in the shaft bearing areas. Anything more would require coupling shaft replacement.

14. Remove and discard seal ring (4) from housing (18).

- 15.** Remove thrust bearing (15) and thrust washer (14). Inspect for wear, brinelling, corrosion and a full complement of retained rollers.



- 16.** Remove seal (16) and back up ring (17) from housing (18) and backup washer (25). Discard both.



- 17.** Remove housing (18) from vise, invert it and remove and discard seal (20). A blind hole bearing or seal puller is required.



- 18.** Inspect housing (18) assembly for cracks, the machined surfaces for nicks, burrs, brinelling or corrosion. Remove burrs that can be removed without changing dimensional characteristics. Inspect tapped holes for thread damage. If the housing is defective in these areas, discard the housing assembly.

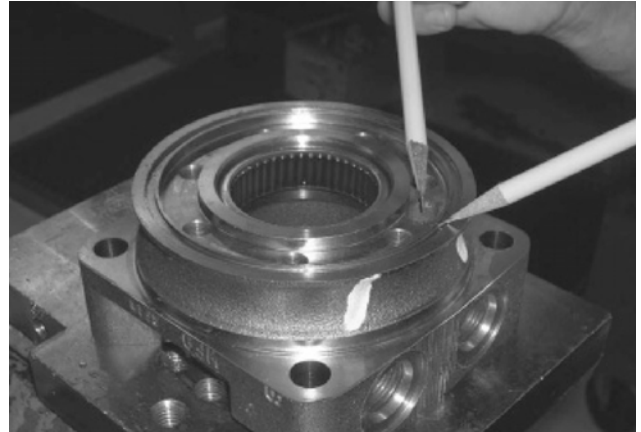

- 19.** If the housing (18) assembly has passed inspection to this point, inspect the housing bearings/bushings (19) and (13) and if they are captured in the housing cavity the two thrust washers (14) and thrust bearing (15). The bearing rollers must be firmly retained in the bearing cages, but must rotate and orbit freely. All rollers and thrust washers must be free of brinelling and corrosion. The bushing (19) or (13) to coupling shaft diameter clearance must not exceed 0.010 inch (0.025 mm). A bearing, bushing, or thrust washer that does not pass inspection must be

SECTION 3 - CHASSIS & TURNTABLE

replaced. If the housing has passed this inspection the disassembly of the motor is completed.

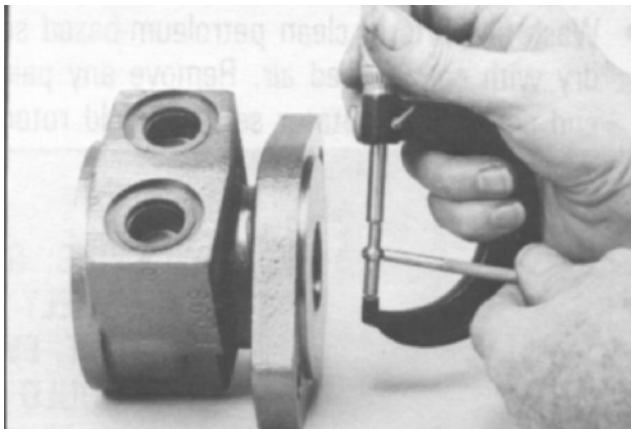

NOTE: The depth or location of bearing/bushing (13) in relation to the housing wear plate surface and the depth or location of bearing/bushing (19) in relation to the beginning of bearing/bushing counter bore should be measured and noted before removing the bearings/bushings. This will facilitate the correct reassembly of new bearings/bushings.



20. If the bearings, bushing or thrust washers must be replaced use a suitable size bearing puller to remove bearing/bushings (19) and (13) from housing (18) without damaging the housing. Remove thrust washers (14) and thrust bearing (15) if they were previously retained in the housing by bearing (13).



Assembly

Replace all seals and seal rings with new ones each time you reassemble the motor unit. Lubricate all seals and seal rings with SAE 10W40 oil or clean grease before assembly.

NOTE: Unless otherwise indicated, do not oil or grease parts before assembly.

Wash all parts in clean petroleum-based solvents before assembly. Blow them dry with compressed air. Remove any paint chips from mating surfaces of the end cover, commutator set, manifold rotor set, wear plate and housing and from port and sealing areas.

⚠ WARNING

SINCE THEY ARE FLAMMABLE, BE EXTREMELY CAREFUL WHEN USING ANY SOLVENT. EVEN A SMALL EXPLOSION OR FIRE COULD CAUSE INJURY OR DEATH.

⚠ WARNING

WEAR EYE PROTECTION AND BE SURE TO COMPLY WITH OSHA OR OTHER MAXIMUM AIR PRESSURE REQUIREMENTS.

1. If the housing (18) bearing components were removed for replacement, thoroughly coat and pack a new outer bearing/bushing (19) with clean corrosion resistant grease recommended in the material section. Press the new bearing/bushing into the counterbore at the mounting flange end of the housing, using the appropriate sized bearing mandrel as described which will control the bearing/ bushing depth.

The housing requires the use of bearing mandrel to press bearing/ bushing (19) into the housing to a required depth of 0.151/0.161 inches (3.84/4.09 mm) from the end of the bearing counterbore.



NOTE: Bearing mandrel must be pressed against the lettered end of bearing shell. Take care that the housing bore is square with the press base and the bearing/ bushing is not cocked when pressing a bearing/bushing into the housing.

⚠ CAUTION

IF A BEARING MANDREL IS NOT AVAILABLE AND ALTERNATE METHODS ARE USED TO PRESS IN BEARING/BUSHING (13) AND (19) THE BEARING/BUSHING DEPTHS SPECIFIED MUST BE ACHIEVED TO INSURE ADEQUATE BEARING SUPPORT AND CORRECT RELATIONSHIP TO ADJACENT COMPONENTS WHEN ASSEMBLED.

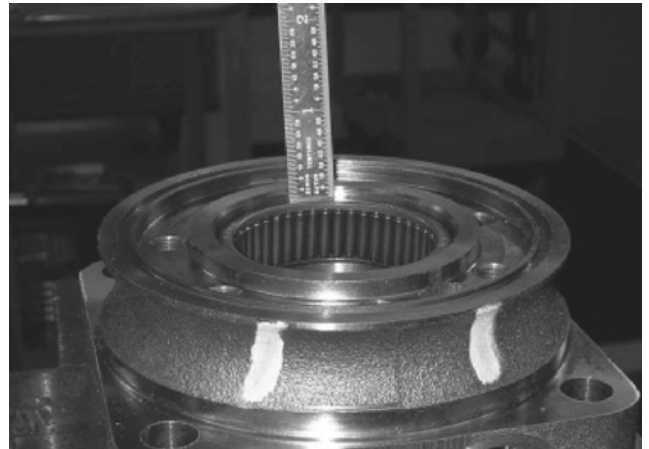

⚠ CAUTION

BECAUSE THE BEARING/BUSHINGS (13) AND (19) HAVE A PRESS FIT INTO THE HOUSING THEY MUST BE DISCARDED WHEN REMOVED. THEY MUST NOT BE REUSED.

2. The inner housing bearing/bushing (13) can now be pressed into its counter-bore in housing (18) flush to 0.03 inch (0.76 mm) below the housing wear plate contact face. Use the opposite end of the bearing mandrel that was used to press in the outer bearing/ bushing (19).

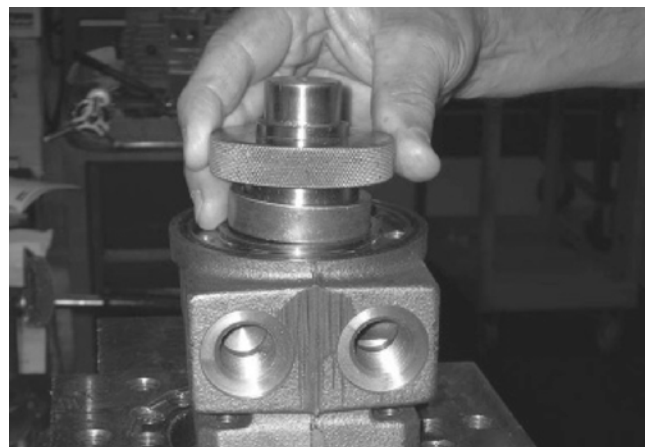

SECTION 3 - CHASSIS & TURNTABLE

3. Press a new dirt and water seal (20) into the housing (18) outer bearing counterbore. The dirt and water seal (20) must be pressed in until its' flange is flush against the housing.

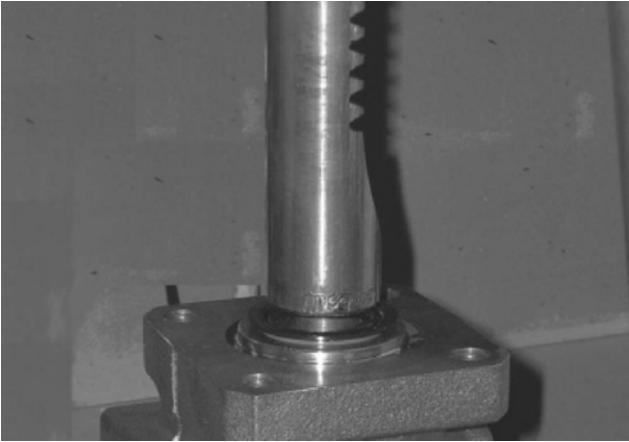

4. Place housing (18) assembly into a soft jawed vise with the coupling shaft bore down, clamping against the mounting flange.

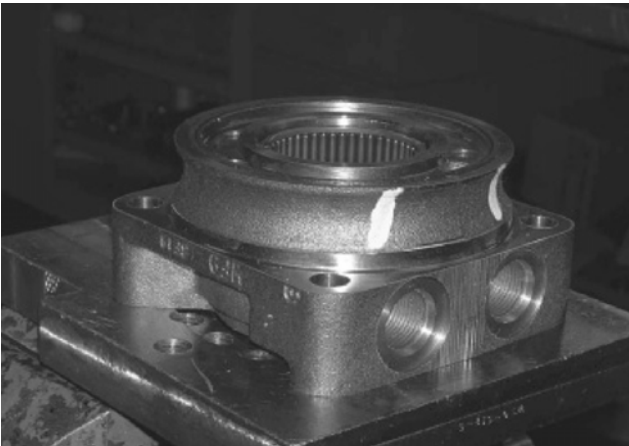

5. Assemble a new backup ring (17), new backup washer (25) and new seal (16) with the seal lip facing toward the inside of the motor, into their respective counterbores in housing (18).

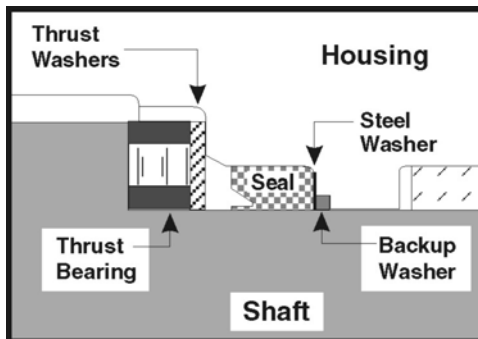

6. Assemble thrust washer (14) then thrust bearing (15) that was removed from the motor.



NOTE: The motor requires one thrust washer (14) with thrust bearing (15). The coupling shaft will be seated directly against the thrust bearing.

7. Apply masking tape around splines or keyway on shaft (12) to prevent damage to seal.

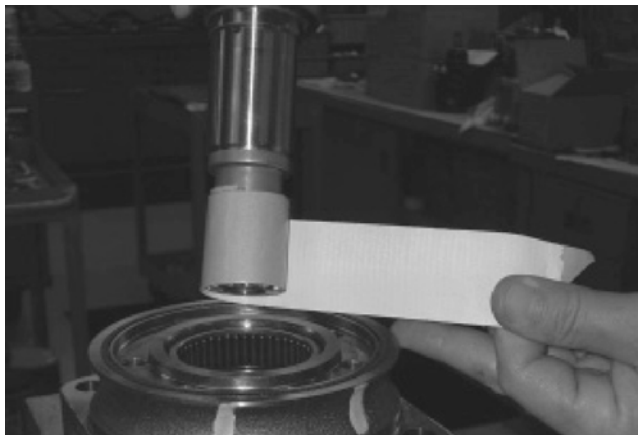

8. Be sure that a generous amount of clean corrosion resistant grease has been applied to the lower (outer) housing bearing/bushing (19). Install the coupling shaft (12) into housing (18), seating it against the thrust bearing (15).

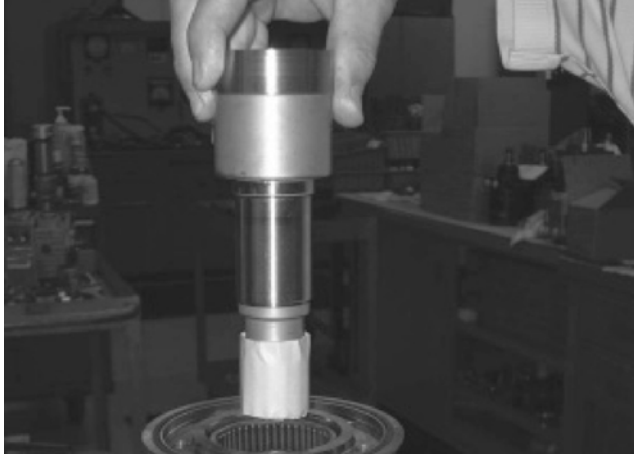

⚠ CAUTION

THE OUTER BEARING (19) IS NOT LUBRICATED BY THE SYSTEM'S HYDRAULIC FLUID. BE SURE IT IS THOROUGHLY PACKED WITH THE RECOMMENDED GREASE.

NOTE: The coupling shaft (12) will be flush or just below the housing wear surface when properly seated while the coupling shaft (12). The coupling shaft must rotate smoothly on the thrust bearing package.

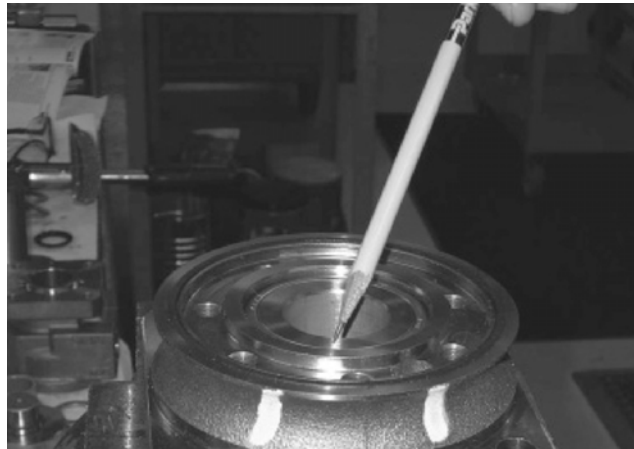

9. Apply a small amount of clean grease to a new seal ring (4) and insert it into the housing (18) seal ring groove.



NOTE: One or two alignment studs screwed finger tight into housing (18) bolt holes, approximately 180 degrees apart, will facilitate the assembly and alignment of components as required in the following procedures. The studs can be made by cutting off the heads of either 3/8-24 UNF 2A or 5/16-24 UNF 2A bolts as required that are over 0.5 inch (12.7 mm) longer than the bolts (1) used in the motor.

10. Install drive link (10) the long splined end down into the coupling shaft (12) and engage the drive link splines into mesh with the coupling shaft splines.



NOTE: Use any alignment marks put on the coupling shaft and drive link before disassembly to assemble the drive link splines in their original position in the mating coupling shaft splines.

SECTION 3 - CHASSIS & TURNTABLE

11. Assemble wear plate (9) over the drive link (10) and alignment studs onto the housing (18).



12. Apply a small amount of clean grease to a new seal ring (4) and assemble it into the seal ring groove on the wear plate side of the rotor set stator.

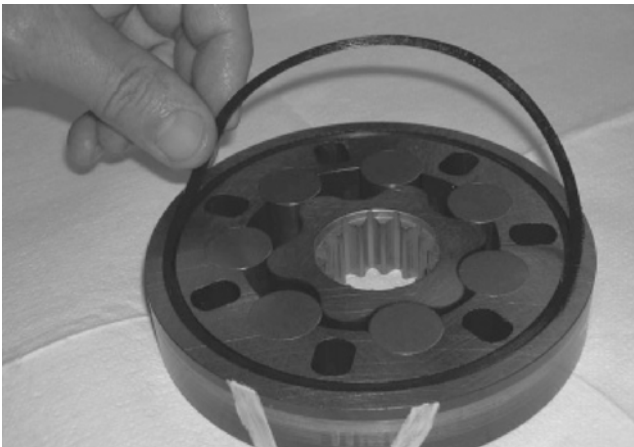

13. Install the assembled rotor set (8) onto wear plate (9) with rotor counterbore and seal ring side down and the splines into mesh with the drive link splines.



NOTE: It may be necessary to turn one alignment stud out of the housing (18) temporarily to assemble rotor set (8) or manifold (7) over the drive link.

NOTE: If necessary, go to the appropriate, "Rotor Set Component Assembly Procedure."

NOTE: The rotor set rotor counterbore side must be down against wear plate for drive link clearance and to maintain the original rotor-drive link spline contact. A rotor set without a counterbore and that was not etched before disassembly can be reinstalled using the drive link spline pattern on the rotor splines if apparent, to determine which side was down. The rotor set seal ring groove faces toward the wear plate (9).

14. Apply clean grease to a new seal ring (4) and assemble it in the seal ring groove in the rotor set contact side of manifold (7).

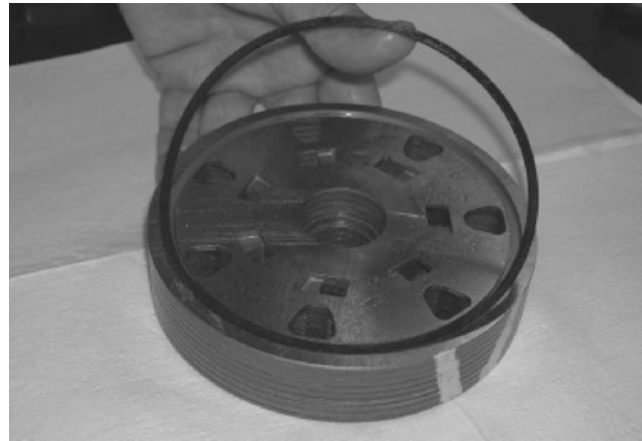

NOTE: The manifold (7) is made up of several plates bonded together permanently to form an integral component. The manifold surface that must contact the rotor set has its series of irregular shaped cavities on the largest circumference or circle around the inside diameter. The polished impression left on the manifold by the rotor set is another indication of which surface must contact the rotor set.

- 15.** Assemble the manifold (7) over the alignment studs and drive link (10) and onto the rotor set. Be sure the correct manifold surface is against the rotor set.

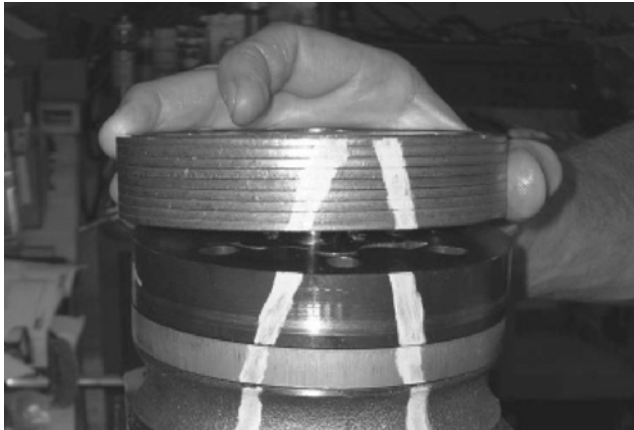

- 16.** Apply grease to a new seal ring (4) and insert it in the seal ring groove exposed on the manifold.



- 17.** Assemble the commutator ring (6) over alignment studs onto the manifold.

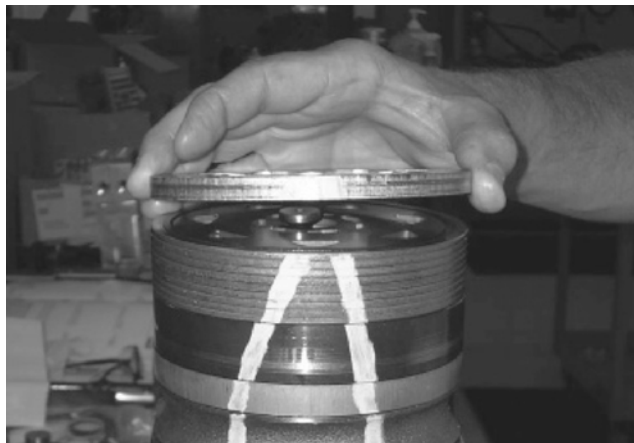

- 18.** Assemble a new seal ring (3) flat side up, into commutator (5) and assemble commutator over the end of drive link (10) onto manifold (7) with seal ring side up.



- 19.** Assemble a new seal ring (4) into end cover (2) and assemble end cover over the alignment studs and onto the commutator set. If the end cover has only 5 bolt holes be sure the cover holes are aligned with the 5 threaded holes in housing (18). The correct 5 bolt end cover bolt hole relationship to housing port bosses is shown below.

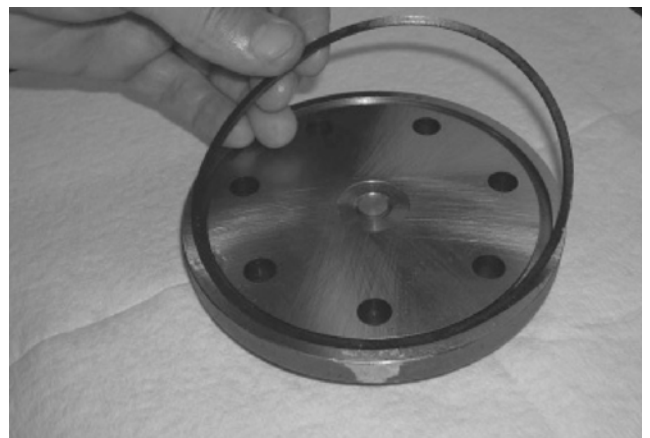

SECTION 3 - CHASSIS & TURNTABLE

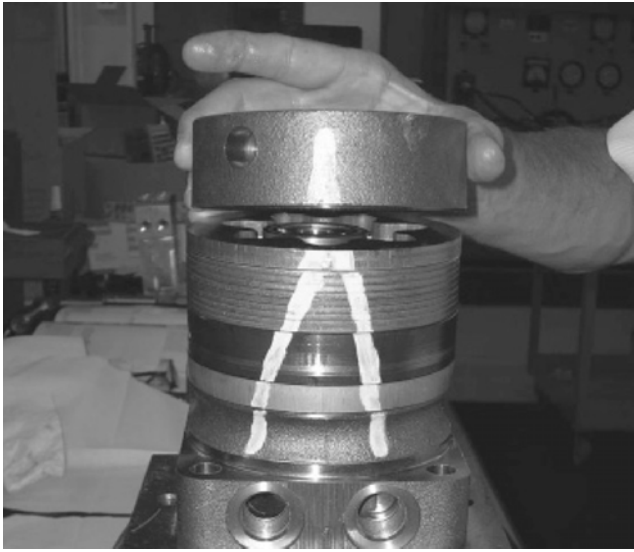

20. Assemble the bolts (1) and screw in finger tight. Remove and replace the two alignment studs with bolts after the other bolts are in place. Alternately and progressively tighten the bolts to pull the end cover and other components into place with a final torque of 25-30 ft. lbs. (34-41 N m).

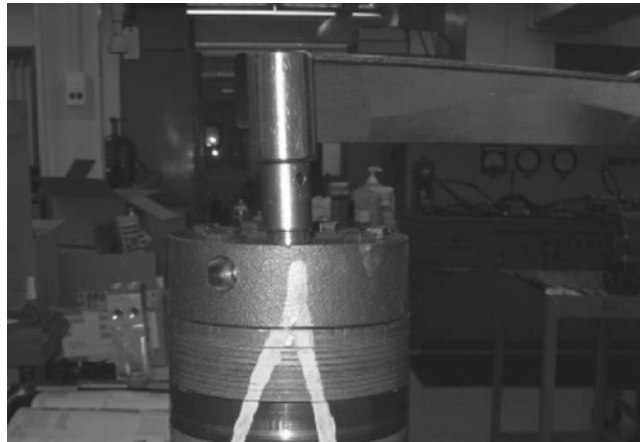
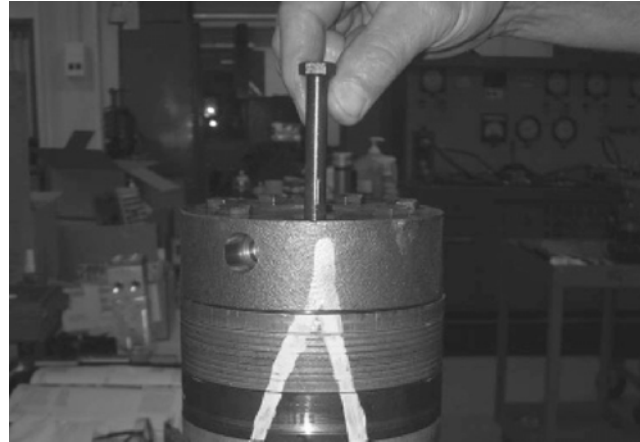

NOTE: If the end cover has a valve (24) or has five bolt holes, use the line you previously scribed on the cover to radially align the end cover into its original position.

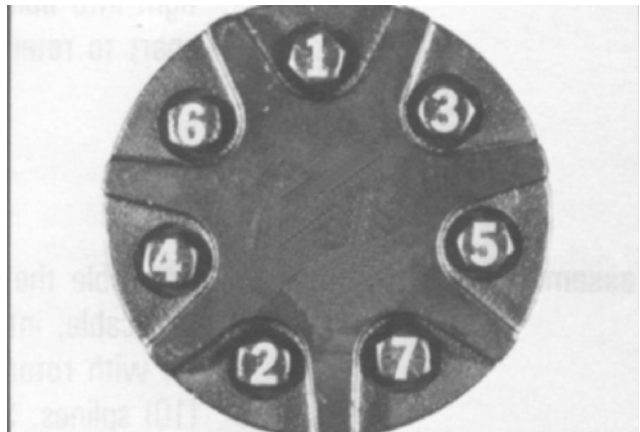

One Piece Stator Construction

A disassembled rotor stator and vanes that cannot be readily assembled by hand can be assembled by the following procedures.

1. Place stator onto wear plate (9) with seal ring (4) side down, after following assembly procedures 1 through 13. Be sure the seal ring is in place.



2. If assembly alignment studs are not being utilized, align stator bolt holes with wear plate and housing bolt holes and turn two bolts (1) finger tight into bolt holes approximately 180 degrees apart to retain stator and wear plate stationary.
3. Assemble the rotor, counterbore down if applicable, into stator, and onto wear plate (9) with rotor splines into mesh with drive link (10) splines.

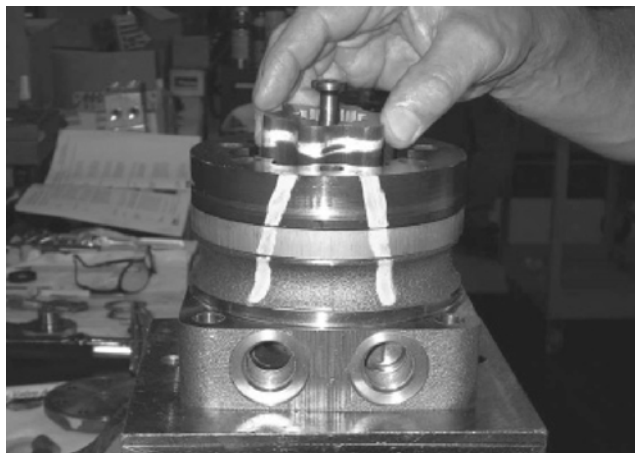

4. Assemble six vanes, or as many vanes that will readily assemble into the stator vane pockets.



⚠ CAUTION

EXCESSIVE FORCE USED TO PUSH THE ROTOR VANES INTO PLACE COULD SHEAR OFF THE COATING APPLIED TO THE STATOR VANE POCKETS.

5. Grasp the output end of coupling shaft (12) with locking pliers or other appropriate turning device and rotate coupling shaft, drive link and rotor to seat the rotor and the assembled vanes into stator, creating the necessary clearance to assemble the seventh or full complement of seven vanes. Assemble the seven vanes using minimum force.



6. Remove the two assembled bolts (1) if used to retain stator and wear plate.

Go to assembly procedure #15, to continue assembly.

Two Piece Stator Construction

A disassembled rotor set (8) that cannot be readily assembled by hand and has a two piece stator can be assembled by the following procedures.

1. Place stator half onto wear plate (9) with seal ring (4) side down, after following motor assembly procedures 1 through 13. Be sure the seal ring is in place.
2. Align stator bolt holes with wear plate and housing bolts and turn two alignment studs finger tight into bolt holes approximately 180 degrees apart to retain stator half and wear plate stationary.
3. Assemble rotor, counterbore down if applicable, into stator half, and onto wear plate (9) with rotor splines into mesh with drive link (10) splines.

NOTE: Use any marking you applied to rotor set components to reassemble the components in their original relationship to ensure ultimate wear life and performance.

4. Assemble six vanes, or as many vanes that will readily assemble into the stator vane pockets.

CAUTION

EXCESSIVE FORCE USED TO PUSH THE ROTOR VANES INTO PLACE COULD SHEAR OFF THE COATING APPLIED TO THE STATOR VANE POCKETS.

5. Grasp the output end of coupling shaft (12) with locking pliers or other appropriate turning device and rotate coupling shaft, drive link and rotor to seat the rotor and the assembled vanes (8C) into stator half, creating the necessary clearance to assemble the seventh or full complement of seven vanes. Assemble the seven vanes using minimum force.
6. Place second stator half on a fl at surface with seal ring groove up. Apply a small amount of grease to a new seal ring (4) and assemble it into stator half ring groove.
7. Assemble the second stator half over the two alignment studs and rotor with seal ring side down onto the first stator half aligning any timing marks applied for this purpose.

CAUTION

IF THE STATOR HALF (8B) IS A DIFFERENT HEIGHT (THICKNESS) THAN STATOR HALF (8D) THE STATOR VANES (8C) OR (8E) OF THE SAME LENGTH (HEIGHT) AS THE STATOR HALF MUST BE REASSEMBLED IN THEIR RESPECTIVE STATOR HALF FOR THE ROTOR SET TO FUNCTION PROPERLY.

8. Assemble six vanes, or as many vanes that will readily assemble into the stator vane pockets.
9. Grasp the output end of coupling shaft (12) with locking pliers or other appropriate turning device and rotate coupling shaft, drive link and rotor to seat the rotor and the assembled vanes into stator, creating the necessary clearance to assemble the seventh or full complement of seven vanes. Assemble the seven vanes using minimum force.

Go to assembly procedure #15, to continue assembly.

Final Checks

1. Pressurize the motor with 100 p.s.i. dry air or nitrogen and submerge in solvent to check for external leaks.
2. Check motor for rotation. Torque required to rotate coupling shaft should not be more than 50 ft. lbs. (68 N m)
3. Pressure port with "A" cast under it on housing (18) is for clockwise coupling shaft rotation as viewed from the output end of coupling shaft. Pressure port with "B" cast under it is for counter clockwise coupling shaft rotation.
4. Use test stand if available, to check operation of the motor.

3.8 SWING BEARING

Turntable Bearing Mounting Bolt Condition Check

NOTE: This check is designed to replace the existing bearing bolt torque checks on JLG Lifts in service. This check must be performed after the first 50 hours of machine operation and every 600 hours of machine operation thereafter. If during this check any bolts are found to be missing or loose, replace missing or loose bolts with new bolts and torque to the value specified in the torque chart, after lubricating the bolt threads with loctite #271. After replacing and retorquing bolt or bolts recheck all existing bolts for looseness.

1. Check the frame to bearing attach bolts as follows:
 - a. Elevate the fully retracted boom to 70 degrees (full elevation).
 - b. At the positions indicated on Figure 3-12. try and insert the 0.0015" feeler gauge between the bolt head and hardened washer at the arrow indicated position.
 - c. Assure that the 0.0015" feeler gauge will not penetrate under the bolt head to the bolt shank.
 - d. Swing the turntable 90 degrees, and check some selected bolts at the new position.
 - e. Continue rotating the turntable at 90 degrees intervals until a sampling of bolts have been checked in all quadrants.
2. Check the turntable to bearing attach bolts as follows:
 - a. Elevate the fully retracted boom to 70 degrees (full elevation).
 - b. At the positions indicated on Figure 3-13. try and insert the 0.0015" feeler gauge between the bolt head and hardened washer at the arrow indicated position.
 - c. Lower the boom to horizontal and fully extend the boom.
 - d. At the position indicated on Figure 3-12. try and insert the 0.0015" feeler gauge between the bolt head and hardened washer at the arrow indicated position.

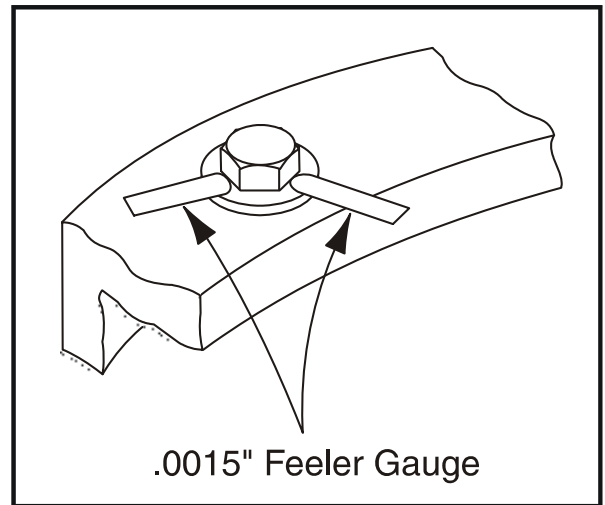

Figure 3-12. Swing Bearing Feeler Gauge Check

Wear Tolerance

1. With the boom positioned over the side of the machine, the Upper Boom horizontal with telescope

fully extended and Mid/Lower Boom stowed, (See Figure 3-13.), using a magnetic base dial indicator, measure and record the distance between the swing bearing and turntable. (See Figure 3-14.)

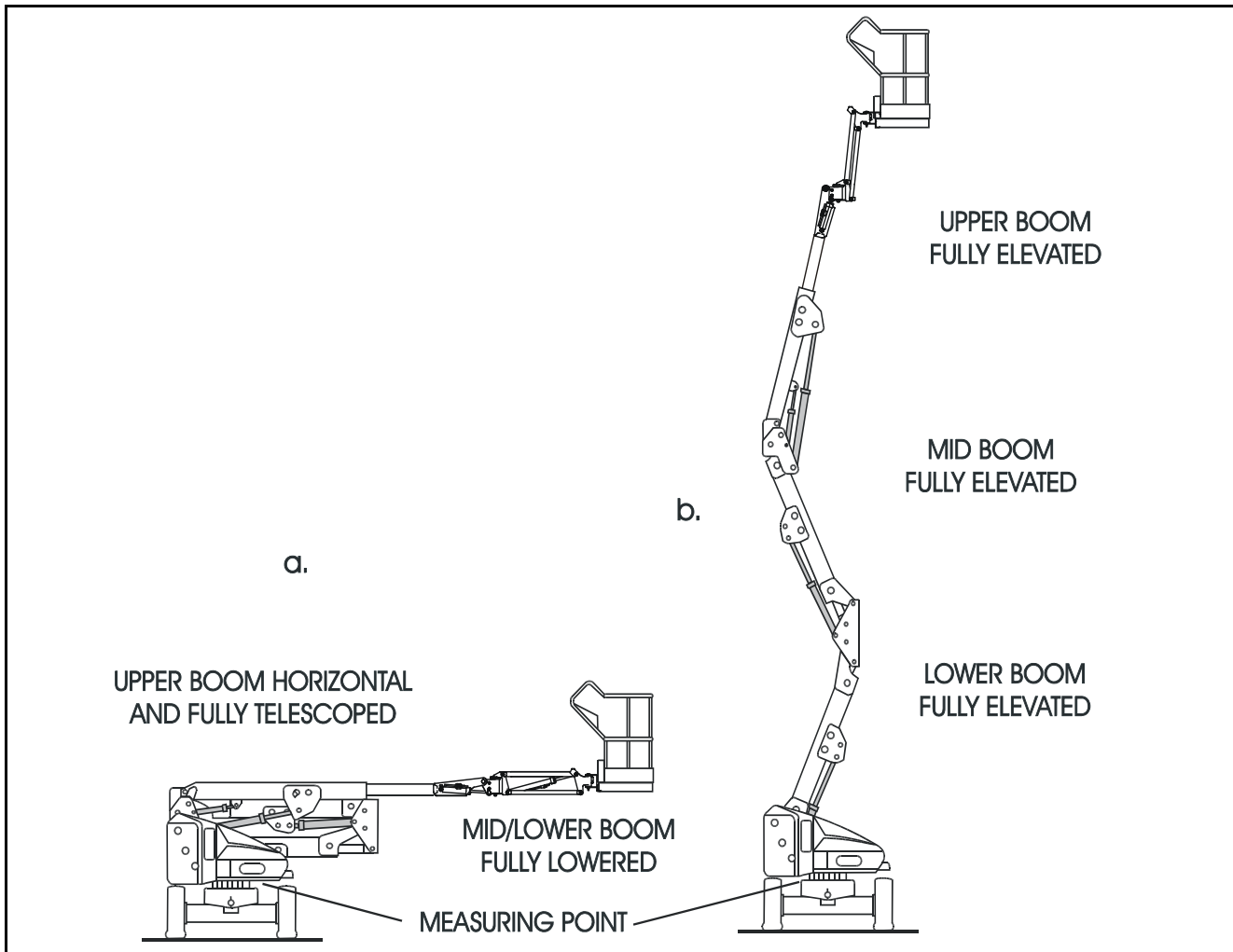

Figure 3-13. Swing Bearing Tolerance Boom Placement

2. At the same point, with the boom positioned over the side of the machine, the Upper Boom fully elevated and the Mid/Lower Boom fully elevated, (See Figure 3-13.) using a magnetic base dial indicator, measure and record the distance between the swing bearing and turntable (See Figure 3-14.).

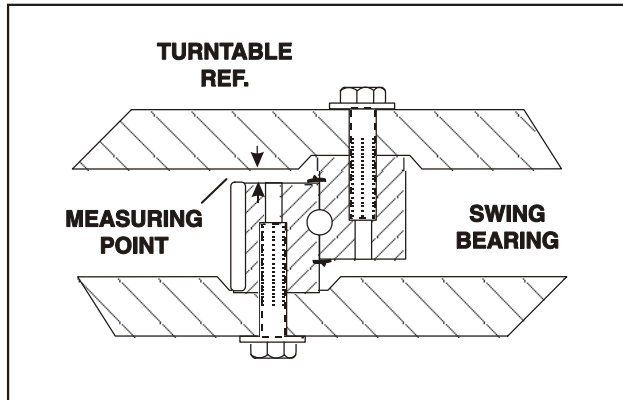

Figure 3-14. Swing Bearing Tolerance Measuring Point

3. If a difference greater than 0.057 in. (1.40 mm) is determined, the swing bearing should be replaced.
4. If a difference less than 0.057 in. (1.40 mm) is determined, and any of the following conditions exist, the bearing should be removed.
 - a. Metal particles in the grease.
 - b. Increased drive power.
 - c. Noise.
 - d. Rough rotation.
5. If bearing inspection shows no defects, reassemble bearing and return to service.

Replacement of Swing Bearing

1. Removal.
 - a. Attach an adequate support sling to the boom and draw all slack from sling. Prop or block the boom if feasible.
 - b. Tag and disconnect hydraulic lines running through center of turntable and frame. Use a suitable container to retain any residual hydraulic fluid. Cap lines and ports.
 - c. Attach suitable overhead lifting equipment to the base of turntable weldment.
 - d. Use a suitable tool to scribe a line on the inner race of the swing bearing and on the underside of the turntable. This will aid in aligning the bearing upon installation. Remove bolts, nuts and washers which attach the turntable to the bearing inner race. Discard nuts and bolts.
 - e. Use the lifting equipment to carefully lift the complete turntable assembly from the bearing. Ensure that no damage occurs to the turntable, bearing or frame mounted components.

- f. Carefully place the turntable on a suitably supported trestle.
- g. Use a suitable tool to scribe a line on the outer race of the swing bearing and the frame. This line will aid in aligning the bearing upon installation. Remove the bolts and washers which attach the outer race of the bearing to the frame. Discard the bolts. Use suitable lifting equipment to remove the bearing and rotation box assembly from the frame; move to a clean, suitably supported work area.
- h. Remove the two capscrews securing the bearing to the rotation box to separate the two for inspection.

2. Installation.

- a. Install bearing to rotation box with two capscrews, so that fill plug of bearing is as close to gear as bolt pattern will allow. Do not tighten capscrews.
- b. Line up high spot (blue) of bearing with center tooth of worm gear. Set backlash to 0.008 - 0.010 inch (0.20 - 0.25 mm). Tighten capscrews as shown in Figure 3-15., Swing Bearing Torquing Sequence.
- c. Apply Tribol Molub-Alloy 936 Open Gear Compound to bearing and worm gear teeth.
- d. Grease bearing with Mobilith SHC Bearing Grease. Grease fitting is on inside wall of inner race of bearing.

NOTE: If Tribol Molub-Alloy 936 Open Gear Compound or Mobilith SHC Bearing Grease are not available, Multi-Purpose Grease (MPG) can be substituted, however the service interval will be shorter.

- e. Using suitable lifting equipment, install bearing/rotation box assembly to frame with soft spot (red) 90 degree relative to load axis. If reusing old bearing, ensure that scribed line of outer race of the bearing aligns with the scribed mark on the frame.

CAUTION

JLG INDUSTRIES RECOMMENDS THAT ALL REMOVED GRADE 8 BEARING NUTS AND BOLTS BE DISCARDED AND REPLACED WITH NEW NUTS AND BOLTS. SINCE THE SWING BEARING IS THE ONLY STRUCTURAL LINK BETWEEN THE FRAME AND TURNTABLE, IT IS IMPERATIVE THAT SUCH REPLACEMENT HARDWARE MEETS JLG SPECIFICATIONS. USE OF GENUINE JLG HARDWARE IS HIGHLY RECOMMENDED.

- f. Apply a light coating of Loctite 271 to the new bearing bolts and loosely install the bolts and washers through the frame and outer race of bearing.

⚠ CAUTION

IF COMPRESSED AIR OR ELECTRICALLY OPERATED IMPACT WRENCH IS USED FOR TIGHTENING THE BEARING ATTACHMENT BOLTS, THE TORQUE SETTING ACCURACY OF THE TOOL SHOULD BE CHECKED PRIOR TO USE.

- g. Following the torque sequence diagram shown in Figure 3-15., tighten the bolts to an initial torque of 130 ft. lbs. (175 Nm). Then following the same sequence, tighten to a final torque of 190 ft. lbs. (260 Nm).
- h. Remove lifting equipment from bearing.

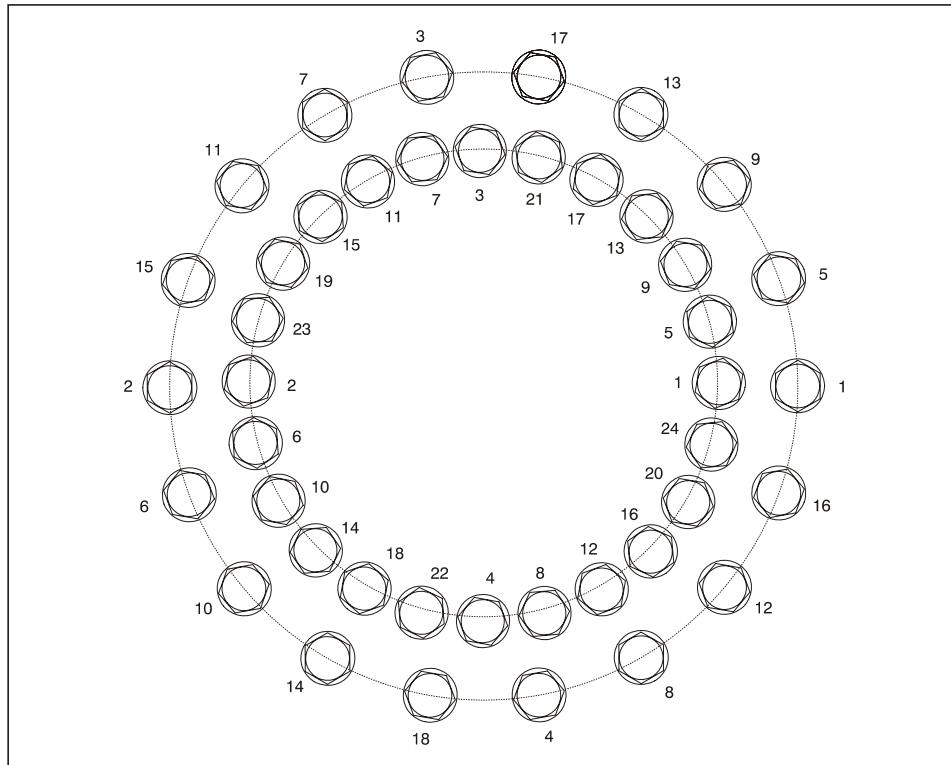

Figure 3-15. Swing Bearing Torquing Sequence

- i. Use suitable lifting equipment to carefully position the turntable assembly above the machine frame.
 - j. Carefully lower the turntable onto the swing bearing. Ensure that the scribed line of the inner race of the bearing aligns with the scribed mark on the turntable. If a new swing bearing is used, ensure that the filler plug fitting is at 90 degrees from the fore and aft centerline of the turntable.
 - k. Apply a light coating of Loctite 271 to the new bearing bolts and install through the turntable and inner race of bearing.
- 3.** Following the torque sequence shown in Figure 3-15., tighten the bolts to an initial torque of 130 ft. lbs. (175 Nm). Then following the same sequence, tighten the bolts to 190 ft. lbs (260 Nm).
- a. Remove the lifting equipment.
 - b. Route hydraulic lines through center of turntable and frame and connect as tagged prior to removal.
 - c. Using all applicable safety precautions, activate the hydraulic system and functionally check swing system for proper and safe operation.

Swing Bearing Torque Value

Install bolts with Loctite - 190 ft. lbs. (260 Nm).

Checking Worm Gear End Play

NOTE: JLG Industries requires that a annual inspection be performed on the worm gear end play.

1. Using a dial indicator, measure end play of worm gear, by applying side to side movement by hand to platform.
2. If tolerance exceeds 0.010", reduce end play to less than 0.005". Refer to Adjusting End Play

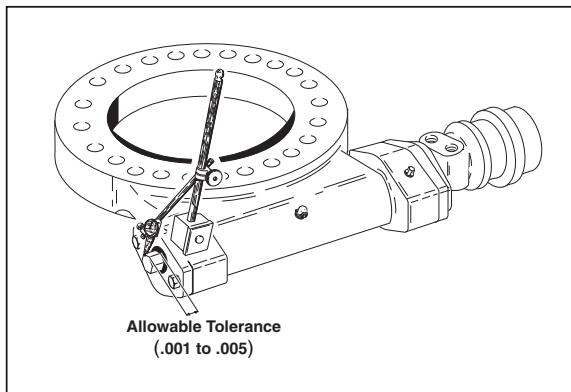

Adjusting End Play

1. Remove end plate.
2. Measure and record total thickness of existing shim pack.
3. Determine thickness of shim pack required to obtain 0.001" - 0.005" end play.
4. Adjust shim pack thickness as required to obtain proper end play. Reduce end play by removing thicker shims and replacing with thinner shims, included in kit.
5. Replace end plate and torque bolts to 90 ft. lbs. (122 Nm).
6. Recheck end play.

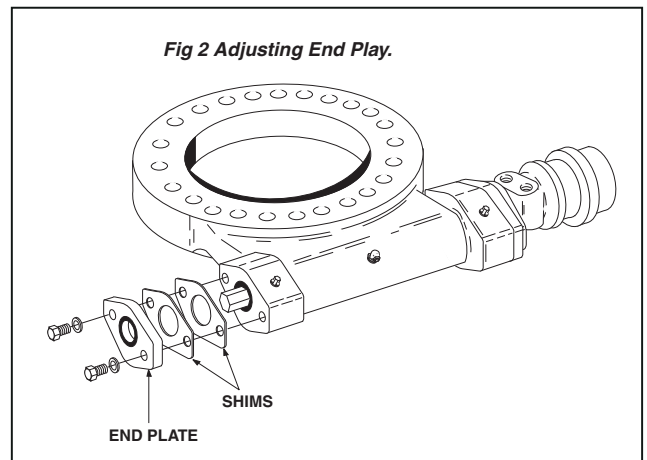

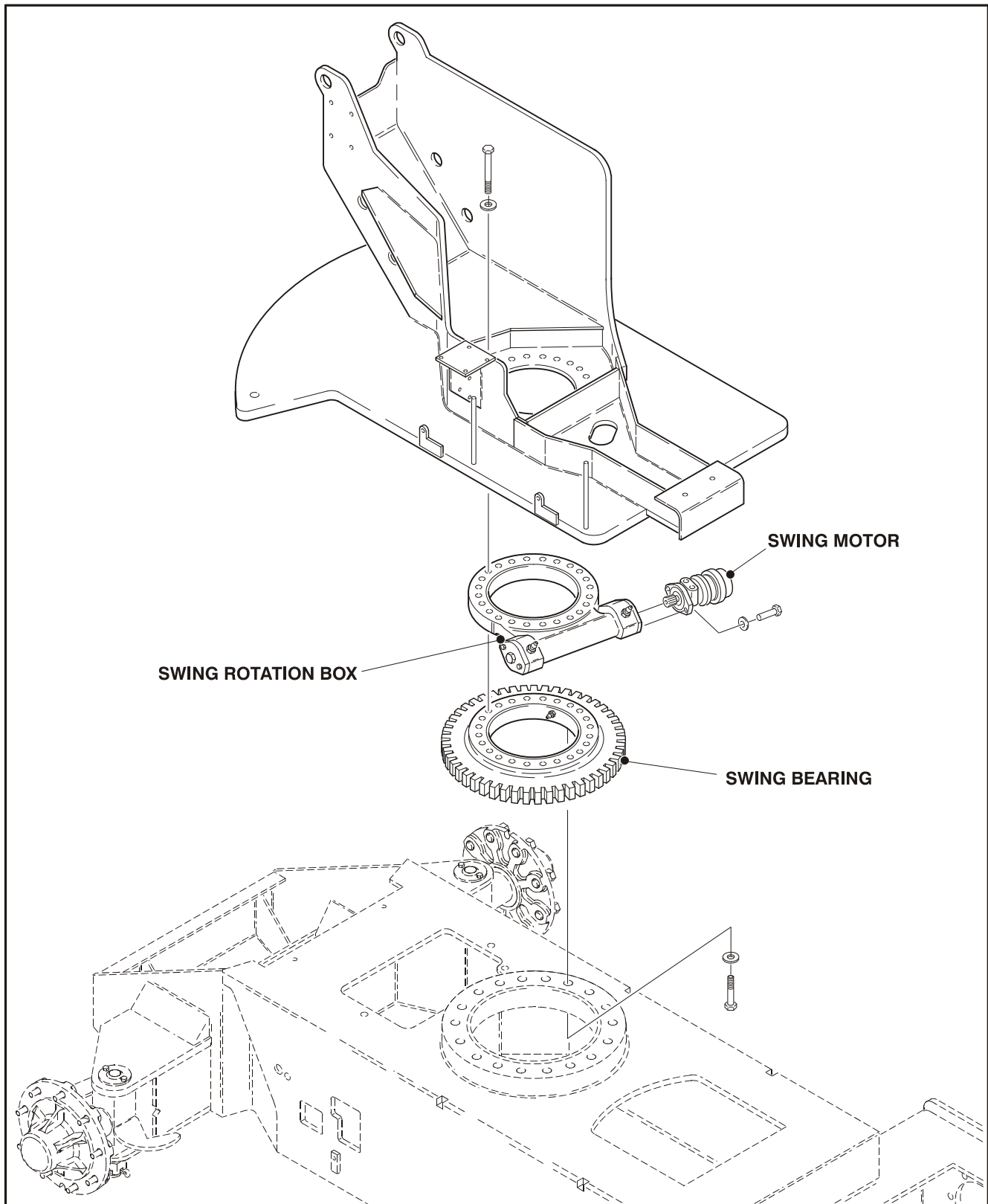

Figure 3-16. Swing Components

3.9 BATTERY MAINTENANCE AND CHARGING

Battery Maintenance, Quarterly

1. Open battery compartment cover to allow access to battery terminals and vent caps.

⚠ CAUTION

WHEN ADDING WATER TO BATTERIES, ADD WATER UNTIL ELECTROLYTE COVERS PLATES. DO NOT CHARGE BATTERIES UNLESS ELECTROLYTE COVERS THE PLATES.

NOTE: *When adding distilled water to batteries, non-metallic containers and/or funnels must be used.*

To avoid electrolyte overflow, add distilled water to batteries after charging.

When adding water to the battery, fill only to level indicated or 3/8" (1 cm) above separators.

2. Remove all vent caps and inspect electrolyte level of each cell. Electrolyte level should be to the ring approximately one inch from top of battery. Fill batteries with distilled water only. Replace and secure all vent caps.
3. Remove battery cables from each battery post one at a time, negative first. Clean cables with acid neutralizing solution (e.g. baking soda and water or ammonia) and wire brush. Replace cables and/or cable clamp bolts as required.
4. Clean battery post with wire brush then re-connect cable to post. Coat non-contact surfaces with mineral grease or petroleum jelly.
5. When all cables and terminal posts have been cleaned, ensure all cables are properly positioned and do not get pinched. Close battery compartment cover.
6. Start hydraulic system and ensure that it functions properly.

Charging Sequence of Remote LED Card

1. Plug in charger.
2. All three LED's (light emitting diode) flash three times.
3. In sequence.
 - a. Green LED flashes once.
 - b. Yellow LED flashes once.
 - c. Red LED flashes once.
4. All Three LED flash three times.
5. Yellow LED comes on indicates charger is charging.
6. Yellow LED will stay on until fully charged and green LED will illuminate.
7. If Red LED remains on, this indicates a fault.

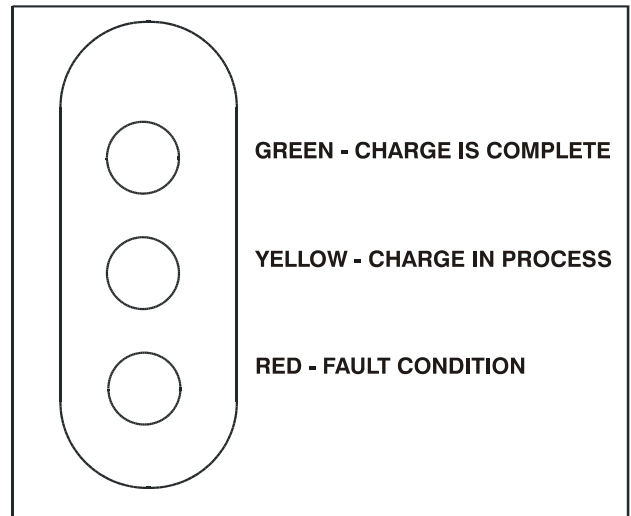

Figure 3-17. Remote LED Card

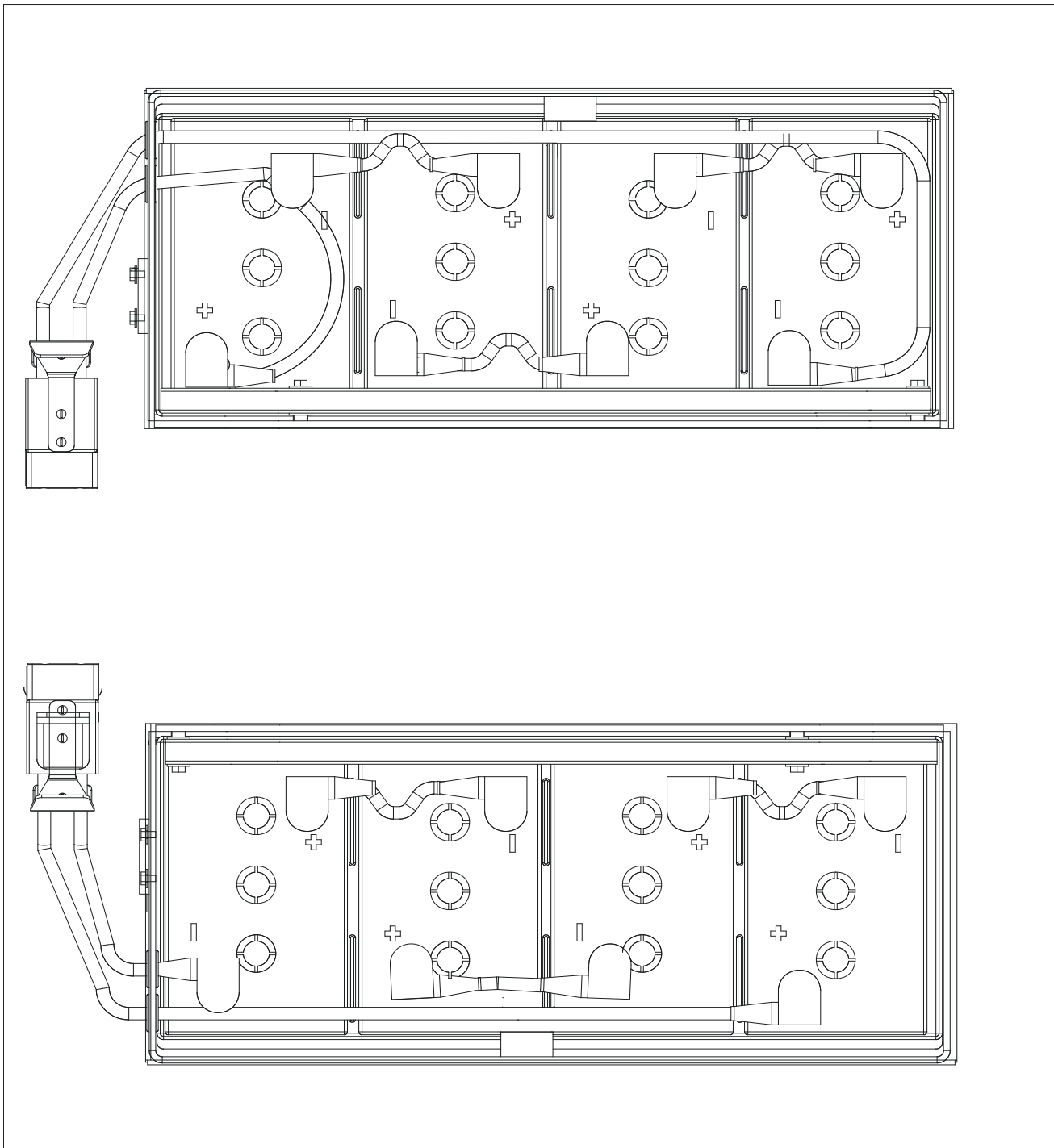

Figure 3-18. Battery Cable Connections

Battery Charging (On Board Charger)

1. For maximum battery life:
 - a. Avoid completely discharging the batteries.
 - b. Fully charge the batteries each day the machine is used.
 - c. Charge the batteries at available times between charging.
 - d. Be sure the battery fluid covers the battery plates before charging, but to avoid overflow, do not top off the fluid level until charging.
2. To charge the batteries, connect the charger to a 115 volt source with a 15 amp minimum capacity.
3. The Charger will shut off automatically when the batteries are fully charged.
4. The charge cycle is complete when the ammeter reads 0 amps. Any reading indicates the charge cycle is not complete.
5. Depleted batteries will take approximately 17 hours to charge.

Optional On Board Generator

⚠ WARNING

EXHAUST GAS HAZARD. RUN THE GENERATOR IN A WELL VENTILATED AREA ONLY.

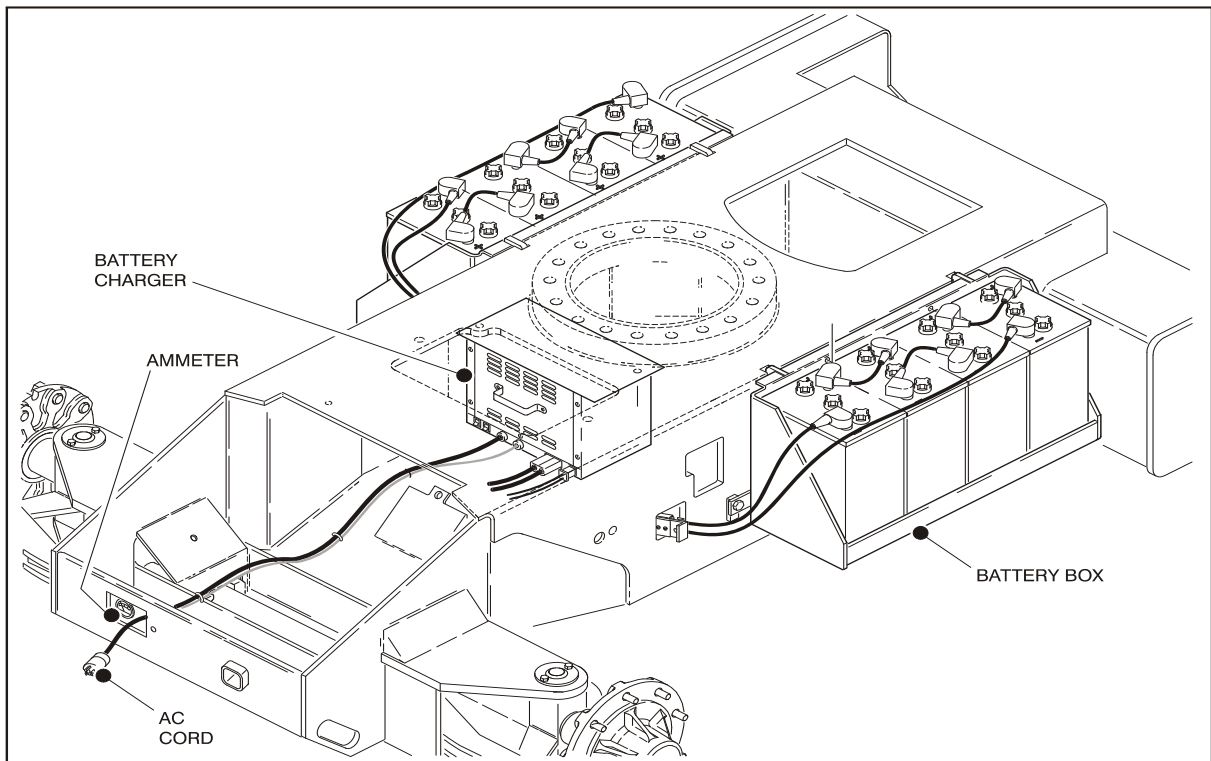

Figure 3-19. Batteries and Battery Charger (Prior to S/N 0300059350)

NOTICE

WHEN THE GENERATOR ENABLE CONTROL LOCATED IN THE PLATFORM CONTROL BOX IS IN THE ON POSITION AND THE GROUND EMERGENCY STOP SWITCH IS ON (PULLED OUT), THE GENERATOR WILL START AUTOMATICALLY WHEN THE BATTERIES REACH A LOW-CHARGE STATE, AUTOMATICALLY CHARGING THE BATTERIES. THE GENERATOR WILL ALSO AUTOMATICALLY START IF THE GENERATOR START BATTERY IS LOW.

NOTE: The engine will automatically shut down under the following conditions:

High Engine Oil Temperature
 Low Engine Oil Pressure
 Engine Overspeed
 Generator Over voltage
 Batteries fully charged
 Engine underspeed

⚠ WARNING

TO AVOID INJURY FROM AN EXPLOSION, DO NOT SMOKE OR ALLOW SPARKS OR A FLAME NEAR BATTERY DURING SERVICING. ALWAYS WEAR EYE AND HAND PROTECTION WHEN SERVICING BATTERIES.

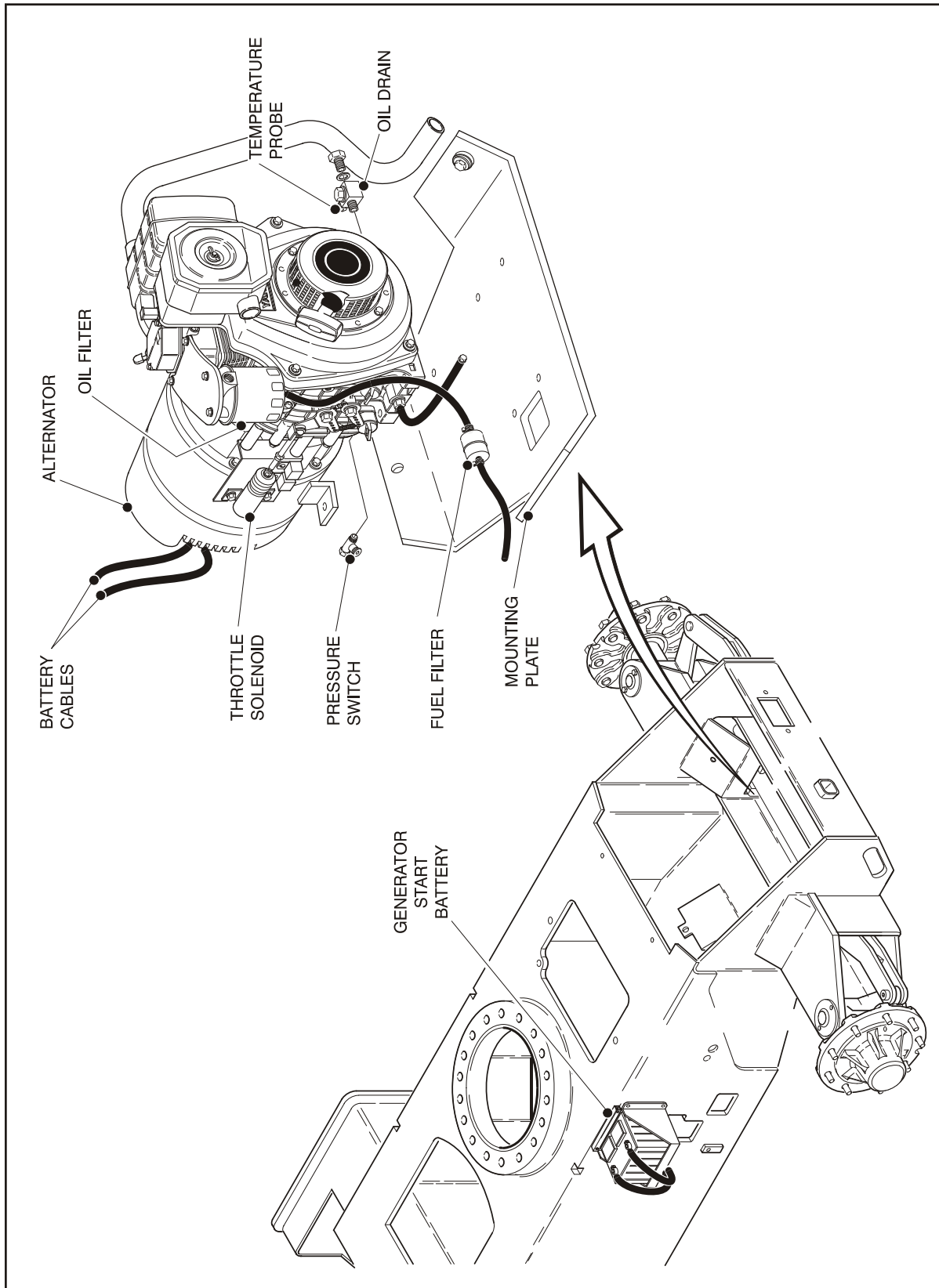

Figure 3-20. On Board Generator

3.10 BATTERY CHARGER (S/N 0300059350 TO PRESENT)

⚠ WARNING

LEAD ACID BATTERIES MAY GENERATE EXPLOSIVE HYDROGEN GAS DURING NORMAL OPERATION. KEEP SPARKS, FLAMES, AND SMOKING MATERIALS AWAY FROM BATTERIES. PROVIDE ADEQUATE VENTILATION DURING CHARGING. NEVER CHARGE A FROZEN BATTERY. STUDY ALL BATTERY MANUFACTURERS' SPECIFIC PRECAUTIONS SUCH AS RECOMMENDED RATES OF CHARGE AND REMOVING OR NOT REMOVING CELL CAPS WHILE CHARGING.

⚠ WARNING

RISK OF ELECTRIC SHOCK. CONNECT CHARGER POWER CORD TO AN OUTLET THAT HAS BEEN PROPERLY INSTALLED AND GROUNDED IN ACCORDANCE WITH ALL LOCAL CODES AND ORDINANCES. A GROUNDED OUTLET IS REQUIRED TO REDUCE RISK OF ELECTRIC SHOCK - DO NOT USE GROUND ADAPTERS OR MODIFY PLUG. DO NOT TOUCH UNINSULATED PORTION OF OUTPUT CONNECTOR OR UNINSULATED BATTERY TERMINAL. DISCONNECT THE AC SUPPLY BEFORE MAKING OR BREAKING THE CONNECTIONS TO THE BATTERY WHILE CHARGING. DO NOT OPEN OR DISASSEMBLE CHARGER. DO NOT OPERATE CHARGER IF THE AC SUPPLY CORD IS DAMAGED OR IF THE CHARGER HAS RECEIVED A SHARP BLOW, BEEN DROPPED, OR OTHERWISE DAMAGED IN ANY WAY - REFER ALL REPAIR WORK TO QUALIFIED PERSONNEL. NOT FOR USE BY CHILDREN.

Operating Instructions

NOTICE

ALWAYS USE A GROUNDED OUTLET. WHEN USING AN EXTENSION CORD, AVOID EXCESSIVE VOLTAGE DROPS BY USING A GROUNDED 3-WIRE 12 AWG CORD.

1. The charger will automatically turn on and go through a short self-test. All LED's will flash in an up-down sequence for two seconds. The yellow "Charging" LED will turn on and a trickle current will be applied until a minimum voltage is reached.
2. Once a minimum battery voltage of 2 volts per cell is detected, the charger will enter the constant-current charging stage and the yellow LED will remain on. The length of charge time will vary by input voltage and ambient temperature.
3. When the green "Charged" LED turns on, the batteries are completely charged. The charger may now be unplugged from AC power. If left plugged in, the charger will automatically restart a complete charge cycle if battery voltage drops below a minimum voltage or 30 days have elapsed.

4. If a fault occurred during charging, the red "Fault" LED will flash with a code corresponding to the error.

Maintenance Instructions

1. For flooded lead-acid batteries, regularly check water levels of each battery cell after charging and add distilled water as required to level specified by battery manufacturer. Follow the safety instructions recommended by the battery manufacturer.
2. Make sure charger connections to battery terminals are tight and clean.
3. Do not expose charger to oil or to direct heavy water spraying when cleaning vehicle.

Battery Charger Fault Codes

If a fault occurred during charging, the red "Fault" LED will flash with a code corresponding to the error. Refer to the table following for the flash codes and their removal.

Table 3-11. Battery Charger Fault Codes (Delta-Q)

Flash(s)	Fault	Fault Removal
1	Battery voltage high	Auto-recover - Indicates a high battery pack voltage
2	Battery voltage low	Auto-recover - Indicates either a battery pack failure, battery pack not connected to charger or battery volts per cell is less than 0.5 VDC. Check the battery pack and connections
3	Charge time-out	Indicates the batteries did not charge in the allowed time. This could occur if the batteries are a larger capacity than the algorithm is intended for or if the batteries are damaged old or in poor condition.
4	Check battery	Indicates the batteries could not be trickle charged up to the minimum voltage per cell level required for the charge to be started.
5	Over-temperature	Auto-recover - Indicates charger has shut down due to high internal temperature
6	QuiQ fault	Indicates that the battery will not accept charge current, or an internal fault has been detected in the charger. This fault will nearly always be set within the first 30 seconds of operation. Once it has been determined that the batteries and connections are not faulty and fault 6 is again displayed after interrupting AC power for at least 10 seconds, the charger must be brought to a qualified service depot.

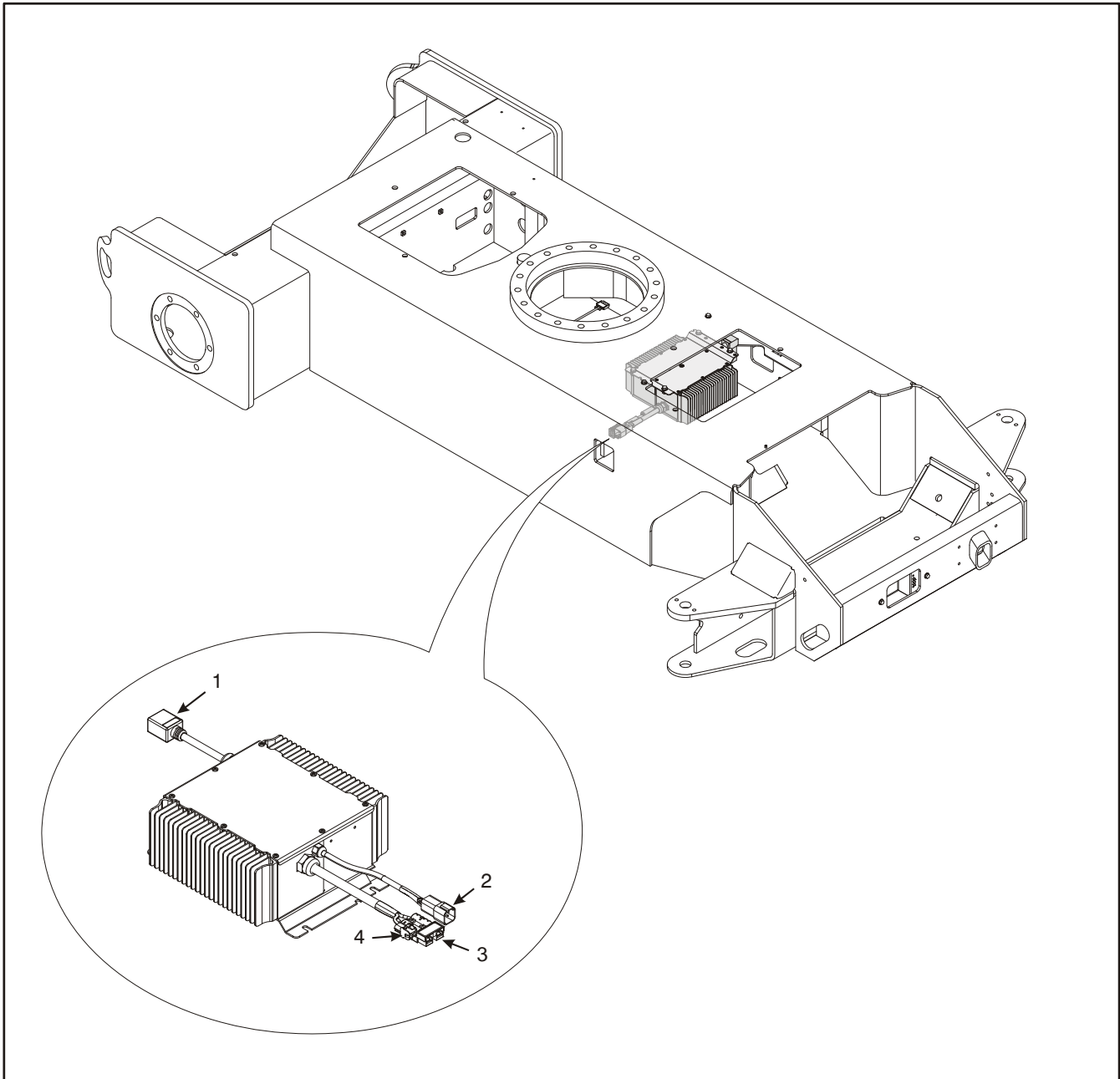

- 1. AC Voltage - Input Cable
- 2. Charger Interlock Cable
- 3. DC Power Cable to Batteries
- 4. LED Indicator Cable

Figure 3-21. Battery Charger ((S/N 0300059350 to Present)

NO LIGHTS AT ALL

No Lights at all indicate that AC power to the charger is not connected or that the AC voltage is too low. It could also indicate an internal failure in the charger.

1. Check the connections to AC power. Check for AC voltage between 90 and 260 VAC at the charger.
2. If the AC voltage is verified to be correct at the connection to the charger, and the charger still displays no lights at all, return the charger for service.

FAULT LED FLASHING

The Fault LED flashes to indicate the microcontroller inside the battery charger has detected a fault. The fault detected is indicated by the number of flashes. Count the number of flashes to determine the fault.

With any battery system, the most common problem will be a faulty battery connection. Because of the high likelihood of a battery connection problem, it is always worthwhile to confirm that all connections are good before checking for any other problems.

[1 Flash] - High Battery Voltage

1. Indicates a high battery voltage. Check that the battery charger voltage is consistent with the battery pack voltage. The first two digits of the four digit model name indicate the battery voltage the charger supports.
2. Check for wiring errors.
3. This fault will automatically clear and the charger will restart charging when this problem is removed.
4. High battery voltage could also occur if there is another source charging the battery. Disconnect any other sources during charging.
5. If this problem does not clear after the battery voltage is confirmed to be less than 2.4V per cell, return the charger for service.

[2 Flashes] - Low Battery Voltage

1. Indicates either a battery failure, no battery connected, or a lower than expected battery voltage. Check the battery and battery connections.
2. Check the nominal battery voltage. The first two digits of the four digit model name indicate the battery voltage the charger supports. Confirm that a nominal battery voltage is the same as the charger voltage.
3. This fault will clear automatically when the low battery voltage problem is rectified.
4. If this problem does not clear after the battery voltage is confirmed to be higher than 1.0V per cell and all connections are good, return the charger for service.

[3 Flashes] - Charge Timeout

Indicates the battery failed to charge within the allowed time. This could occur if the battery is of larger capacity than the algorithm is intended for. In unusual cases it could mean charger output is reduced due to high ambient temperature. It can also occur if the battery is damaged, old, or in poor condition.

1. Check the battery for damage such as shorted cells and insufficient water. Try the charger on a good battery.
2. If the same fault occurs on a good battery, check the connections on the battery and connection to AC, and the AC voltage itself.
3. Confirm that the nominal battery pack voltage is the same as the battery charger voltage.
4. This fault must be cleared manually by unplugging the AC, waiting 30 seconds and reconnecting the AC power.
5. If a charger displays this fault on a battery pack, and the pack is of questionable status, reset the charger by disconnecting AC for 30 seconds, and then reconnect the AC to start a new charge cycle. After a few charge cycles, this problem could stop occurring as the pack "recovers."

[4 Flashes] - Check Battery

This fault indicates the battery pack could not be trickle charged up to the minimum level required for the normal charge cycle to be started.

1. Check that none of the battery pack connections between modules are reversed or incorrectly connected.
2. Check that one or more cells in the battery are not shorted.
3. Confirm that the nominal battery pack voltage is the same as the battery charger voltage.
4. Try the charger on a good battery.
5. If this fault occurs, the battery is likely in poor condition. Try to recover the pack with a charger that can charge the individual cells - such as an automotive charger. Be sure to set this charger to the appropriate voltage - 6V per 6V battery, 12V per 12V string/battery.

[5 Flashes] - Over Temperature

This fault indicates the charger has become too hot during operation. Though not damaging to the charger, charge time will be extended significantly.

1. This fault indication will not clear automatically, but the charger will restart charging automatically when the temperature drops. The fault indication must be cleared manually by unplugging the AC, waiting 30 seconds and reconnecting the AC power.
2. If possible, move the machine to a cooler location.
3. Confirm that dirt or mud is not blocking the cooling fins of the charger. Clean the charger. Rinse the charger with a low pressure hose if required. Do not use high pressure. Do not use a pressure washer.

[6 Flashes] - Over Load/Over Temperature

This fault indicates that the batteries will not accept charge current, or an internal fault has been detected in the charger. This fault will nearly always be set within the first 30 seconds of operation. If it occurs after the charger has started charging normally, be sure to make a note of it.

1. Remove excessive AC loads from inverter if installed.
2. Try to clear the fault by unplugging the AC, waiting 30 seconds and reconnecting the ac power.
3. Check all battery connections. Look for a high resistance connection. The most likely reason for this fault is a fault in the battery such as a bad battery connection, an open cell, or insufficient water.
4. This fault will occur if an internal fuse inside the charger blows. If the green wire is shorted to ground even momentarily, this fuse will blow. To check the fuse, measure with an ohmmeter between the green and red wires with the AC disconnected. If a short circuit is not measured, the fuse has blown. Return unit to a service depot to have this fuse replaced.
5. If this fault occurs after battery charging has started, confirm that AC power was not interrupted and that all battery connections are good.
6. If all battery connections are good, an internal fault has been detected and the charger must be brought to a qualified service depot.

Excessive Battery Watering Requirements or Strong Sulphur (Rotten Egg) Smell

These symptoms indicate over-charging or high battery temperature. These symptoms are unlikely to be caused by too high a charge current since the maximum charge current of the charger will be small compared to even a moderately sized battery pack. The most likely cause for this problem is incorrect charge algorithm setting and/or high ambient temperatures.

1. Confirm that the battery pack is not too small - usually > 50Ah.
2. Confirm that the nominal battery voltage matches the charger output voltage.
3. Confirm the correct battery charge algorithm. If the battery pack is new, the algorithm will need to be changed if the pack is not the same as the old one. For instructions on how to determine and change the battery charge algorithm see the following sub-section.
4. If the output voltage of the charger seems excessive, return the charger for service. Contact JLG to get the expected battery voltage settings for the charger in question. Be sure to have the charger's serial number and charge algorithm setting available when calling.

Checking/Changing the Battery Charger Algorithm

The charger is pre-loaded with programming algorithms for the specific batteries detailed in Table 3-4, Battery Algorithms.

NOTE: Contact JLG if your specific battery model is not listed.

Each time AC power is applied with the battery pack not connected, the charger enters an algorithm select/display mode for approximately 11 seconds. During this time, the current Algorithm # is indicated on the Yellow Charging LED. A single digit Algorithm # is indicated by the number of blinks separated by a pause. A two digit Algorithm # is indicated by the number of blinks for the first digit followed by a short pause, then the number of blinks for the second digit followed by a longer pause.

To check / change the charging algorithm:

1. Disconnect the charger positive connector from the battery pack. Apply AC power and after the LED test, the Algorithm # will display for 11 seconds.
2. To change the algorithm, touch the connector to the battery's positive terminal for 3 seconds during the 11 second display period and then remove. The Algorithm # will advance after 3 seconds. Repeat this procedure until the desired Algorithm # is displayed. A 30 second timeout is extended for every increment. Incrementing beyond the last Algorithm will recycle back to the first Algorithm. When the desired Algorithm is displayed, touch the charger connector to the battery positive terminal until the output relay makes a clicking noise (approx. 10 seconds). The algorithm is now in the permanent memory.

3. Remove the AC power from the charger and reconnect the charger's positive connector to the battery. It is recommended to check a newly changed algorithm by repeating the above steps 1 and 3.

Table 3-4. Battery Algorithms

Algorithm #	JLG P/N	Battery Type	Proper Algorithm Setting
173	1001114782	DISCOVER EV 305A-A	43
173	0400055	US BATT L16	173

3.12 GENERATOR (PRIOR TO S/N 88539)

NOTE: Throughout the Generator section, the abbreviations RBS and CTS are used. RBS stands for Rotary Battery System, which is the generator system. CTS stands for Call To Start, which is the electronic inputs which signal the generator to start and charge the batteries.

The generator consists of a drive engine, controller, and related components.

Alternator

The alternator is a brushless, DC output alternator. The 3 phase output of the alternator is full wave rectified and directed to the output terminator.

The output rating is 58 volts DC at 45 amps. Voltage regulation and current limiting is provided by the Engine/Generator Controller.

The rectifier diodes and output current sensor are located in the alternator end.

Dynamo and Dynamo Voltage Regulator

The engine is equipped with a 12 Volt, 15 Amp DC output dynamo.

Dynamo Output Fuse

The dynamo output fuse is used to protect the output of the dynamo. This fuse is rated at 20 Amps DC, slow blow and is located on the left side of the engine.

Control Fuse

This fuse provides power to the engine/generator and the relays for start control, fuel control, and pre-heater. This fuse is rated at 15 Amps DC and is located on the right side of the engine.

Start Battery

A 12 volt lead-acid battery is utilized to provide starting power for the generator and power for the generator controls. This battery is charged by the engine dynamo and dynamo regulator when the engine is running.

Engine Starter

The engine is equipped with a 12 Volt DC starter. This starter provides mechanical power to crank the engine. Electrical power for the starter is provided by the start battery. The starter is energized by the start control relay.

Start Control Relay

The start control relay energizes the solenoid of the engine starter and the pull coil of the engine fuel solenoid.

The start control relay is located on the fuel solenoid bracket on the right side of the engine. The start control relay is energized by the engine/generator controller.

Fuel Control Relay

The fuel control relay energizes the hold coil of the fuel solenoid. The fuel control relay is energized by the engine/generator controller.

Fuel Solenoid

The fuel solenoid actuates the run/stop lever of the engine. This solenoid has a pull and hold coil. The pull coil is energized by the start control relay and the hold coil is energized by the fuel control relay.

Engine Oil Temperature Sensor

The engine oil temperature sensor is used to sense the temperature of the oil in the sump of the engine. This sensor provides a signal to the engine/generator controller for high engine temperature shutdown.

Alternator Output Current Sensor

The alternator output current sensor provides a signal proportional to the output current of the alternator to the engine/generator controller. This signal is used by the controller to regulate the current output of the alternator. The output current is regulated at 55 Amps DC. The alternator output current sensor is located inside the rear cover of the alternator.

Engine Speed Sensor

The engine speed sensor provides a signal proportional to the rotational speed of the engine to the engine/generator controller. This signal is used by the controller to determine starter cut-out, overspeed fault, and underspeed fault. This signal has fail-safe protection, if it is not present at the controller, the unit will fault with a loss of speed signal indication. The engine speed sensor is located inside the recoil starter cover at the front of the engine.

Engine Low Oil Pressure Switch

The engine is equipped with a low oil pressure switch. The switch is closed when the oil pressure is below 14.2 psi (1 Bar)

Timing Sequences

- RBS Pre-start Sequence

1. Time Delay Engine Start (TDES)

TDES is the period which the RBS waits to verify that the CTS is valid rather than a transient condition.

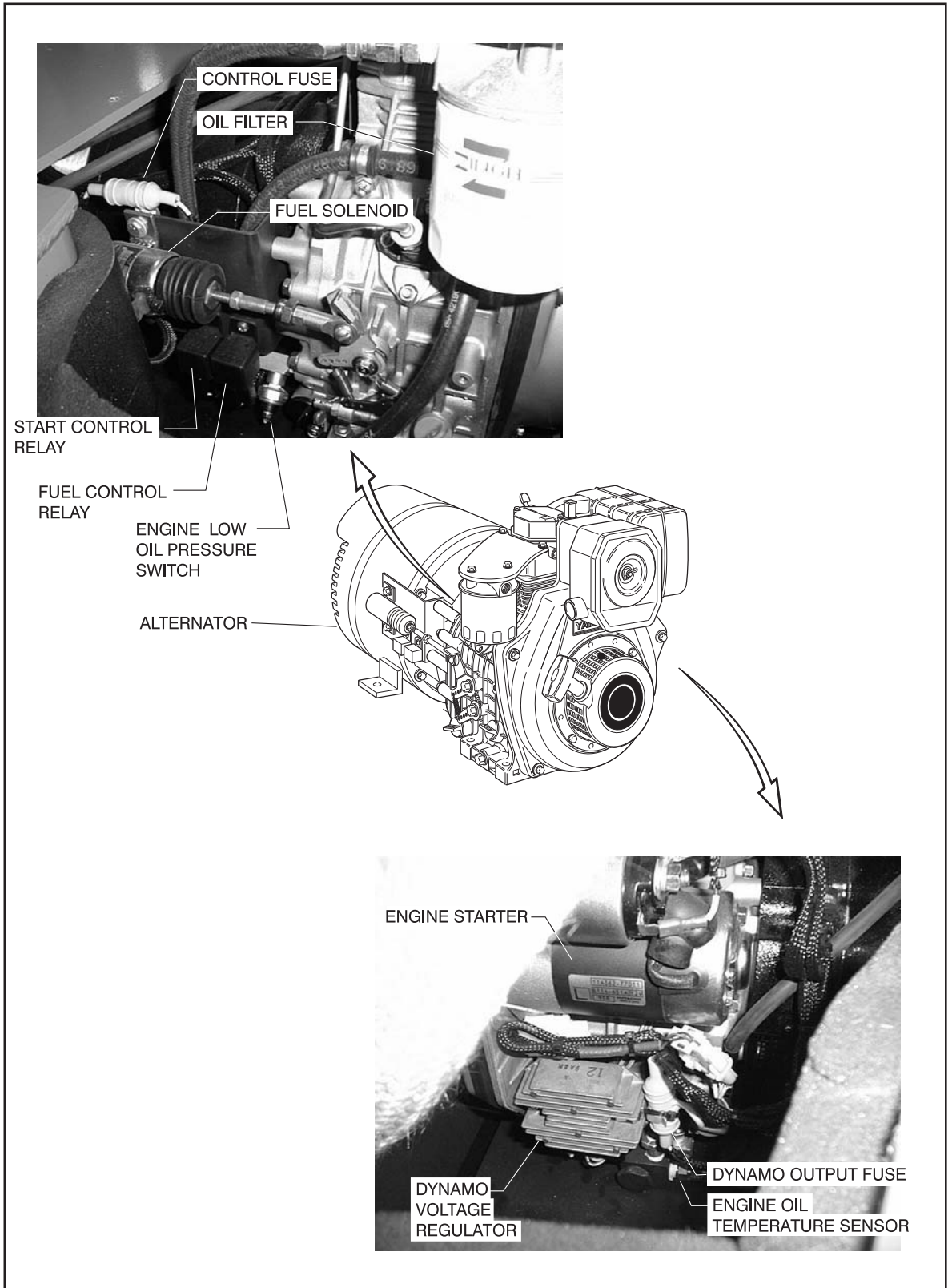

Figure 3-22. Generator Components

2. Time Delay Pre-Heat (TDPH)

TDPH, if enabled, occurs after TDES has elapsed and the engine temperature is below the factory set engine preheat temperature setting. The engine preheater will be energized for the factory set preheat delay period.

Table 3-5. RBS Prestart Sequence

CTS (Call to Start)
TDES (Engine Start)
Preheat Delay
RBS Startup Sequence

• RBS Startup Sequence

3. Crank Time

The RBS will crank for a period up to the crank time or until the engine starts.

4. Rest Time

If the engine does not successfully start, the RBS will wait for the rest time before attempting to crank the engine again.

5. Crank Cycles

The RBS will attempt to start the engine up until the number of crank cycles is reached. If the RBS does not start, an Over crank fault is indicated.

6. Time Delay Bypass (TDBP)

Once the engine starts, TDBP must elapse before low oil pressure and underspeed shutdowns are activated. This allows the engine to come up to normal operating conditions before enabling these shutdowns are monitored.

Table 3-6. RBS Startup Sequence

Crank Time -> Rest Time (Until Engine Start or # of Crank Cycles)
TDBP Bypass
Normal Running Operation

• RBS Shutdown Sequence

Once all CTS conditions have been removed, the RBS will begin the shutdown sequence. If a CTS condition is initiated during the shutdown sequence, the RBS will return to normal running operation until the CTS is removed.

1. Time Delay Engine Run (TDER)

Once the CTS condition is removed, the TDER period begins. This period ensures that no further CTS conditions occur prior to the cool down period.

Time Delay Cool down (TDC)

Once the TDER period ends, the alternator output is reduced to a minimal level in order to allow the engine to cool down for the TDC period. If a CTS is received during the TDC period, the CTS must last for at least the TDES period for the RBS to return to normal running operation.

Table 3-7. RBS Shutdown Sequence

Remove CTS
TDER Engine Run
TDC Cooldown
Engine Stop

To Connect the JLG Control System Analyzer to the Generator

The JLG Control System Analyzer can be used to monitor generator settings and conditions. Connect the analyzer as follows:

1. Connect the four pin end of the cable supplied with the analyzer, to the connector behind the ground control module located on the left side of the machine next to the ground control station and connect the remaining end of the cable to the analyzer. The ground control module contains the settings for the generator.



NOTE: The cable has a four pin connector at each end of the cable; the cable cannot be connected backwards.

2. Power up the Analyzer by pulling out the ground station EMS and positioning the Generator Enable switch on the platform control box to the “on” position. Refer to Figure 3-23., Generator System Analyzer Flow Chart

Alarms and Fault Flash Codes

In the event of an RBS alarm, a flash code will be issued and an alarm indicated on the analyzer.

NOTE: Alarms must be reset once the fault has been corrected.

Table 3-8. Generator System Flash Codes

Code	Alarm	Description
1-1	Low Oil Pressure	Shutdown due to low engine oil pressure
1-2	High Engine Temperature	Shutdown due to high engine oil temperature
1-3	Engine Overspeed	Shutdown due to high engine speed
1-4	Engine Under-speed/Overcrank	Shutdown due to engine overcrank or underspeed
1-5	No Speed Signal	Shutdown due to loss of speed signal
2-1	Overvoltage	Shutdown due to high output voltage
2-2	Engine Starting System fault	Alarm not a shutdown; Indicates problem with the engine starting system
2-3	Not Used	Not Used
2-4	Loss of Voltage Sense	Shutdown due to loss of voltage sensing
Continuous	Unit Disabled	No Faults. RBS enabled and can respond to any CTS
Off	Unit Disabled	RBS off or disabled; Will not respond to any CTS

• Low Oil Pressure

Enabled once TDBP (time delay bypass) period has elapsed after engine startup. If the low engine oil pressure switch closes, the engine will stop immediately and a low oil pressure alarm will be indicated.

• High Engine Temperature

If the engine oil temperature exceeds the high engine temperature setting, the engine will stop immediately and a low oil pressure alarm will be indicated.

SECTION 3 - CHASSIS & TURNTABLE

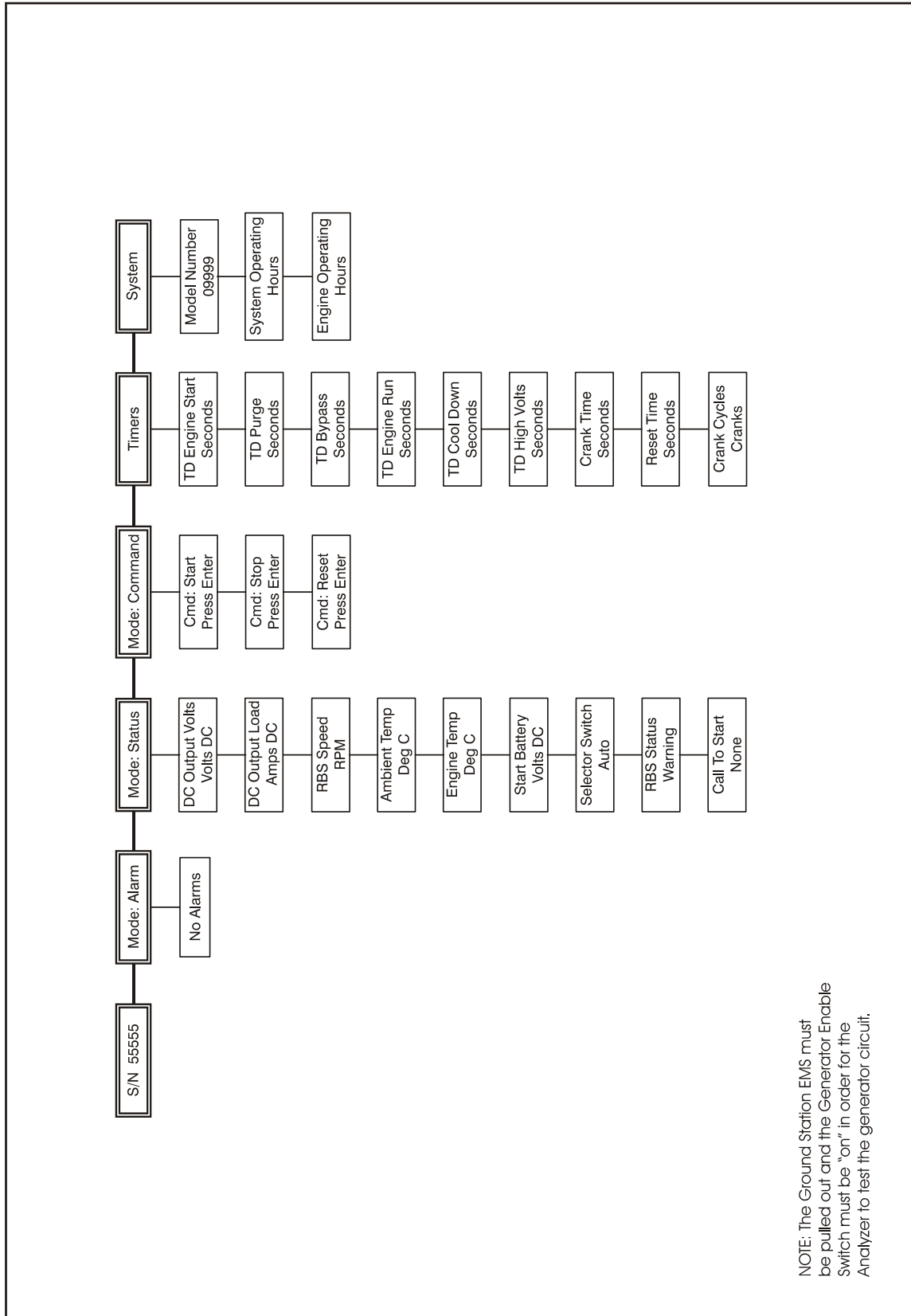

NOTE: The Ground Station EMS must be pulled out and the Generator Enable Switch must be "on" in order for the Analyzer to test the generator circuit.

Figure 3-23. Generator System Analyzer Flow Chart

- **Over Speed**

If the engine speed exceeds the overspeed limit, the engine will stop immediately and an overspeed alarm will be indicated.

- **Underspeed**

Enabled once TDBP (time delay bypass) period has elapsed after engine startup. If the engine speed drops below the underspeed limit, the engine will stop immediately and an engine underspeed alarm will be indicated.

- **Over crank**

If the engine fails to start after a set number of start attempts, the RBS will cease attempts to restart and an engine over crank alarm will be indicated.

- **No Speed Signal**

In the event of a loss of speed signal, the RBS will shut-down and an engine no speed signal alarm will be indicated. This shutdown is delayed by a factory set period to ensure the fault was not momentary.

- **Over voltage**

If the voltage measured at the alternator output exceeds the high voltage setting, the RBS will stop immediately and an RBS high output alarm will be indicated. This shutdown is delayed by a factory set period to ensure the fault was not caused by a transient condition. This feature protects the batteries and load from high DC voltages.

- **Engine Starting System Fault**

Indicates a problem with either the engine start battery, engine magneto, or magneto voltage regulator.

- **Loss Of Voltage Sense**

If the voltage measured at the alternator output is less than half of the system nominal voltage, the RBS will stop immediately and an RBS loss of voltage sense alarm will be indicated. This feature protects the batteries and load from high DC voltages due to a loss of output control.

- **Run Inhibited**

The RBS unit is disabled by the run inhibited input.

Output Current and Voltage Settings

- **Normal/Extended Output Voltage**

The normal/extended output voltage setting is the voltage at which the alternator changes under normal operating conditions.

- **Current Limit**

The current limit setting determines the maximum alternator output current.

- **High Voltage Shutdown Level**

This setting determines the alternator output voltage at which the high voltage shutdown occurs. This protects the load from abnormally high voltages.

- **Finish Charging Current**

The finish charging current determines the level of the current alternator output must drop below for a low battery voltage CTS to be removed. This ensures that the batteries have accepted sufficient charge prior to shutting down the RBS. This level is used along with the low battery voltage remove CTS level to determine when the RBS removes the CTS after a low battery voltage CTS. If the charging current falls below the finish charging current while another CTS is active, the RBS will continue to operate at the normal/extended output voltage until all CTS's are removed.

Priming the Fuel Line

The following procedure is for re-priming the fuel line on the generator engine in the event fuel system components have been replaced or the unit has been run dry of fuel.

1. Make sure the fuel line isn't blocked or kinked.
2. Make sure fuel tank has fuel.
3. Disconnect the rubber fuel line at the fuel injector pump.

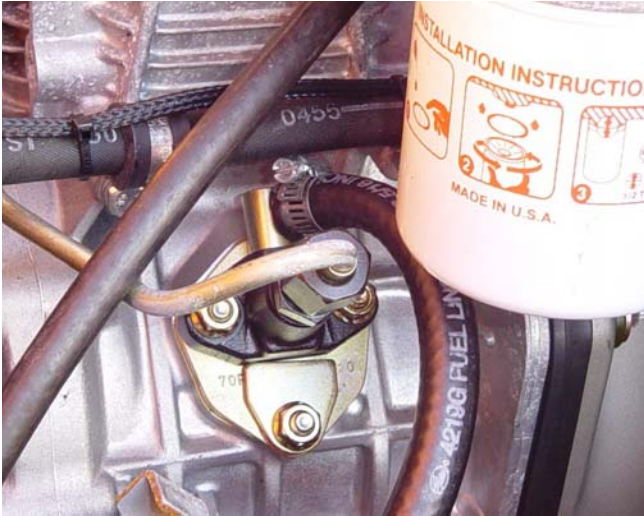

4. When fuel starts to flow out of the rubber line, re-connect the fuel line to the fuel injector pump.
New title here

5. Clean up any spilled fuel and try to start the generator engine.
6. If the engine still doesn't start, remove the steel line from the fuel injector pump.
7. Once fuel starts to flow, re-connect the fuel line to the fuel injector pump.
8. Clean up any spilled fuel and try to start the generator engine.
9. If no fuel flows there are some possibilities:
 - a. There is no fuel getting to the injector pump. No fuel in tank, or obstruction in fuel line, or clogged inline fuel filter.
 - b. The engine/camshaft rotation is not opening the injection fuel pump. Using the recoil starter, rotate the engine 1/3 of a turn and fuel should spill from the fuel injector pump.
10. Engine might run rough for 20 seconds or so, but it will clean out.

3.13 GENERATOR (S/N 88539 TO PRESENT)

NOTE: Throughout the Generator section, the abbreviation RBS is used. RBS stands for Rotary Battery System, which is the generator system.

The engine-driven generator is designed to produce a DC output directly without the need of a separate rectifier. Included in the RBS unit is the engine, generator, engine/generator controller, harness and related components.

Engine

Peak rating:

Continuous rating:

6.2 HP

0.6 HP at 3600 RPM

Refer to the Engine Manual for a complete description of the engine.

Alternator

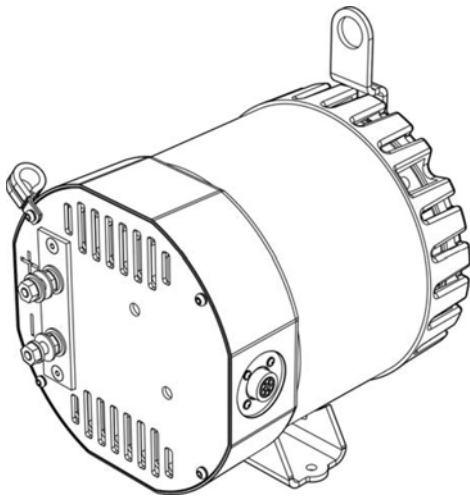

The RBS is equipped with a brushless DC output alternator.

The 3-phase AC output of the alternator is full wave rectified and presented to the output terminals.

Output rating: 58.0V at 45A

Voltage regulation and current limiting is provided by the RBS Engine/Generator Controller.

The rectifier diodes and output current sensor are located in the alternator endbell.

Dynamo and Dynamo Voltage Regulator



The engine is equipped with a dynamo and dynamo voltage regulator.

Dynamo output: 12V
7A DC

Refer to the Engine Manual for a complete description of the dynamo and dynamo voltage regulator.

Dynamo Output Fuse

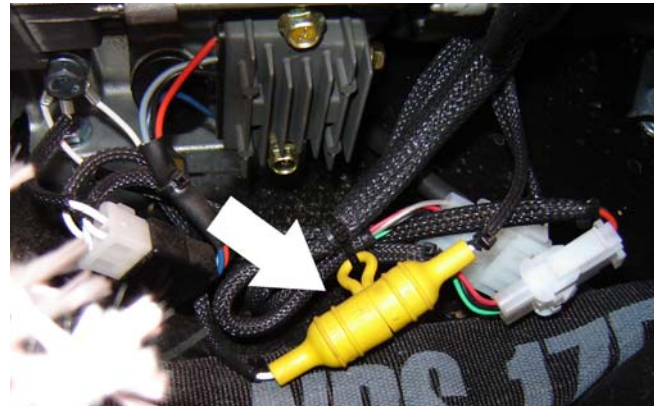

This fuse protects the dynamo output; it is located on the left side of the engine.

Rating: 20ADC

Control Fuse

The control fuse provides power to the engine/generator controller and the relays for start control, fuel control and glow plug.

Rating: 15ADC

This fuse is located on the right side of the engine.

SECTION 3 - CHASSIS & TURNTABLE

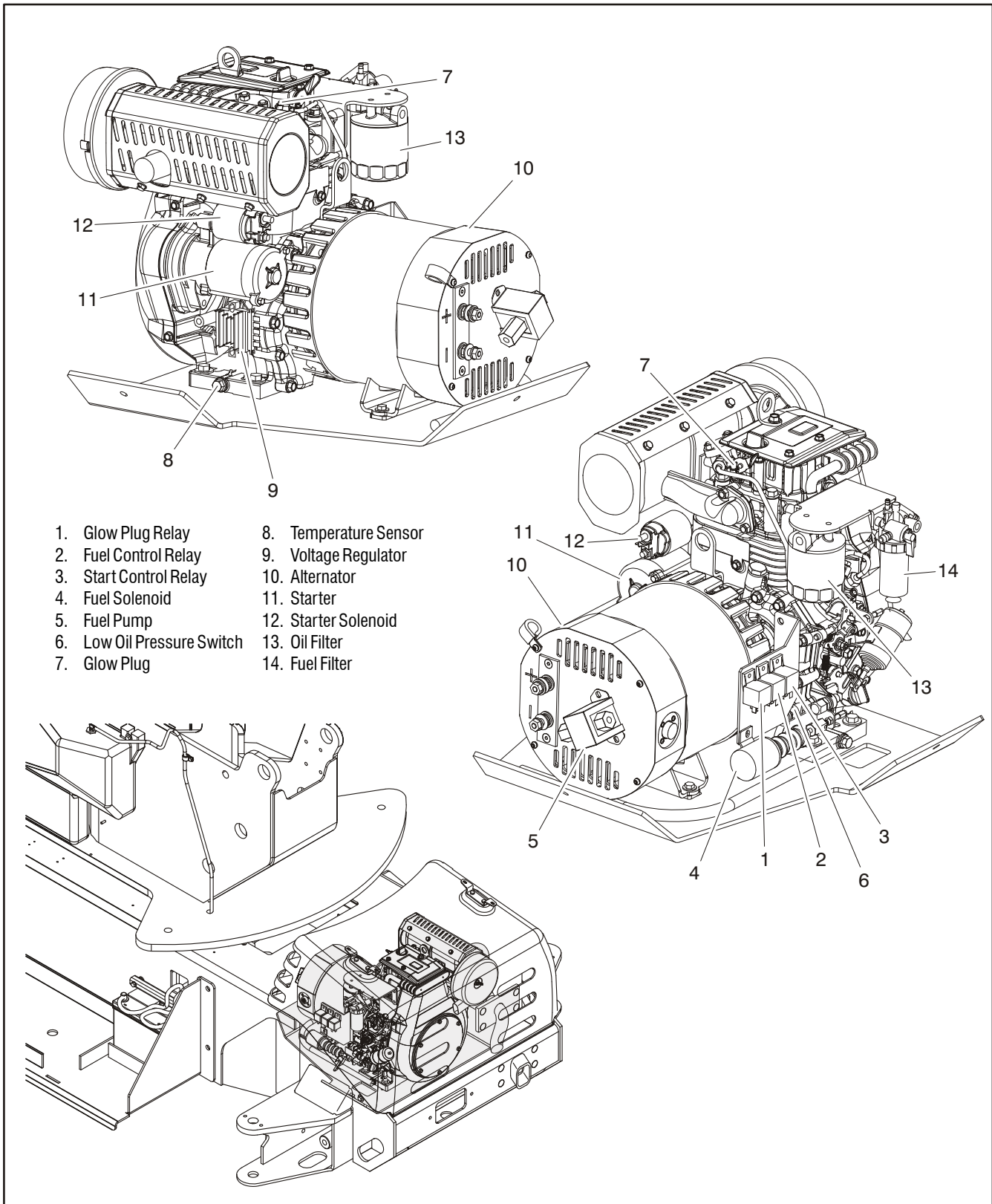

Figure 3-24. Generator

Start Battery



The RBS requires a 12V lead-acid start battery (not supplied with the system), which provides starting power and power for the RBS controls.

This battery is charged by the engine dynamo and dynamo regulator when the engine is running.

Engine Starter

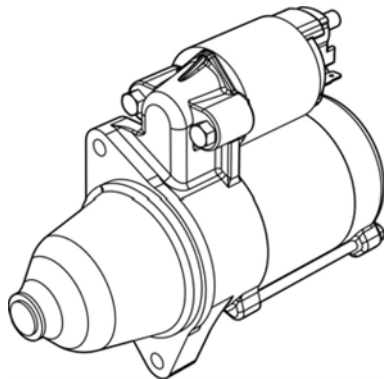

The engine is equipped with a 12VDC starter, which provides the mechanical power to crank the engine. Electrical power for the starter is provided by the start battery.

The starter is energized by the start control relay.

Start Control Relay

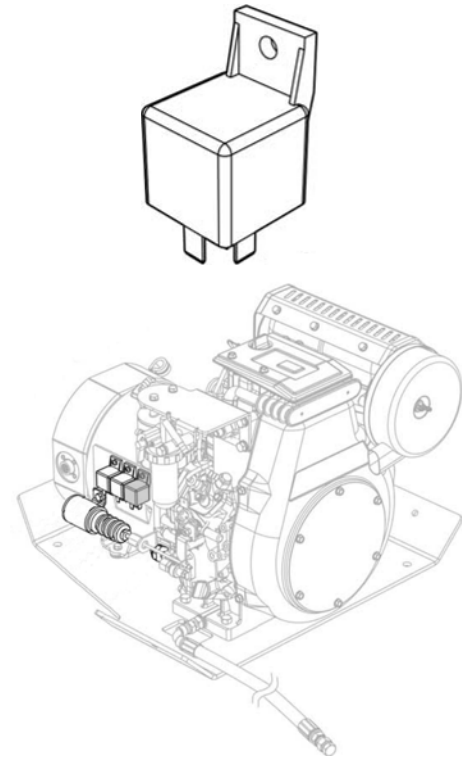

The start control relay energizes the solenoid of the engine starter and the pull coil of the engine fuel solenoid.

The start control relay is energized by the engine/generator controller from pin J2-4.

The start control relay is located on the fuel solenoid bracket on the right side of the engine.

Fuel Control Relay

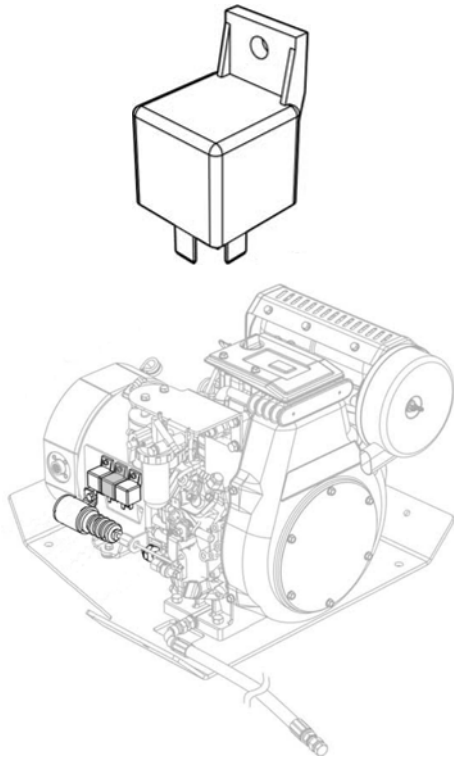

The fuel control relay energizes the hold coil of the fuel solenoid.

The fuel control relay is energized by the engine/generator controller from pin J2-3.

The fuel control relay is located on the fuel solenoid bracket on the right side of the engine.

Glow Plug Control Relay

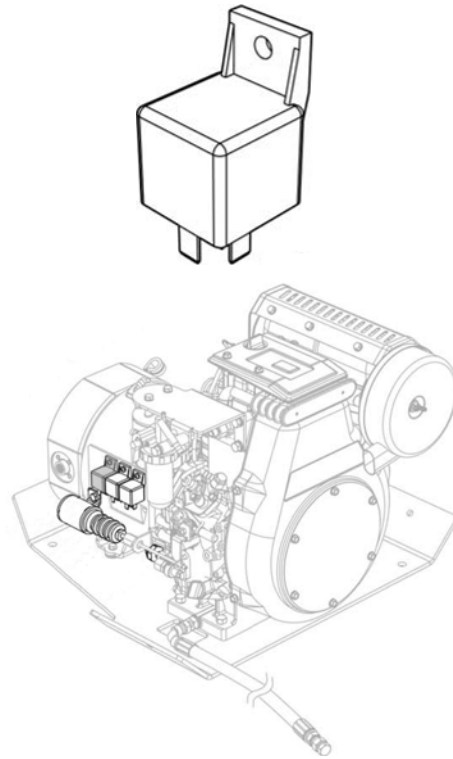

The glow plug control relay energizes the glow plug. It is energized by the engine/generator controller, pin J2-27.

The glow plug control relay is located on the fuel solenoid bracket on the right side of the engine.

Glow Plug

The glow plug is a resistive heating element located in the combustion chamber. It is used during starting at temperatures below 32°F (0°C).

The heater is energized by the glow plug control relay.

Fuel Pump

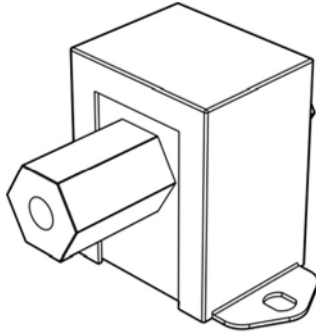

The fuel pump runs in parallel with the fuel solenoid hold coil which is run by the fuel control relay.

The pump runs whenever the engine runs, and keeps the fuel filter filled. Excess fuel flows through the return line back to the fuel tank.

The fuel pump is located on the right side of the engine.

Fuel Solenoid

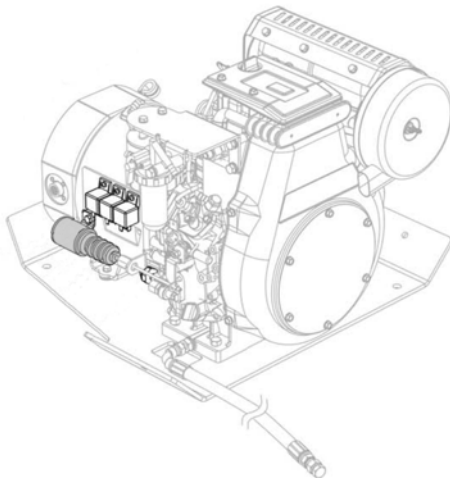
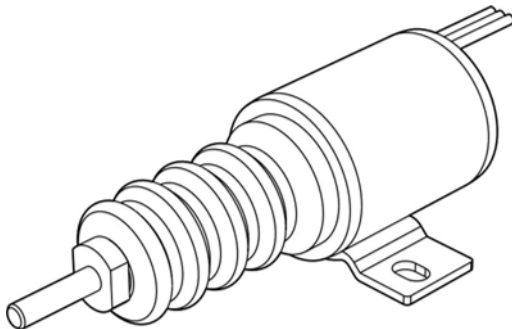

The fuel solenoid actuates the run/stop lever of the engine. This solenoid has a pull coil energized by the start control relay and a hold coil energized by the fuel control relay.

The fuel solenoid is located on the right side of the engine.

Engine Low Oil Pressure Switch

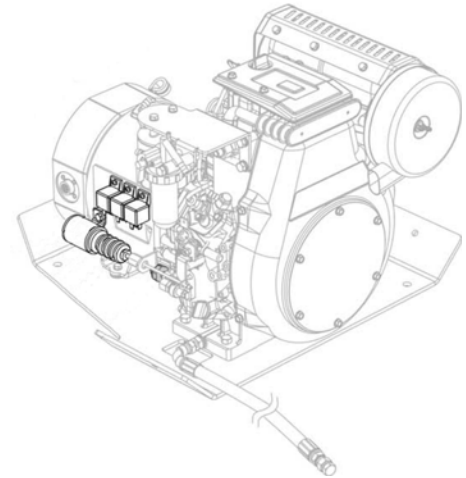

The engine is equipped with a low oil pressure switch. This switch is closed when the oil pressure is below 7psi. It is mounted on the side cover.

Engine Oil Temperature Sensor

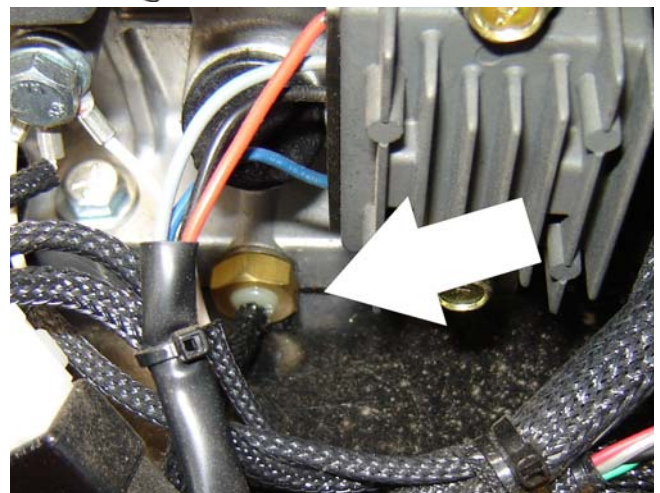
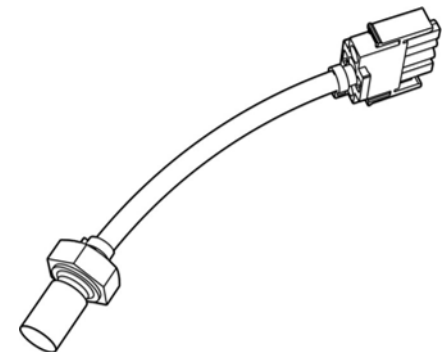

The engine oil temperature sensor is used to sense the temperature of the oil in the sump of the engine.

This sensor provides an analog signal to the engine/generator controller. The primary use of this signal is for high engine temperature shutdown 248°F (120°C) for the

engine. The signal is also used in determining if the air glow plug should be energized.

The engine oil temperature sensor is connected to the engine/generator controller at pins J2-8 and J2-19.

The engine oil temperature sensor is located on the left side of the engine.

Alternator Output Current Sensor

The alternator output current sensor provides a signal proportional to the output current of the alternator to the engine/generator controller. The output current is regulated at 45ADC.

The alternator output current sensor is connected to the engine/generator controller at pins J2-21, J2-31 and J2-32.

The alternator output current sensor is located inside the rear cover of the alternator.

Engine Speed Sensor

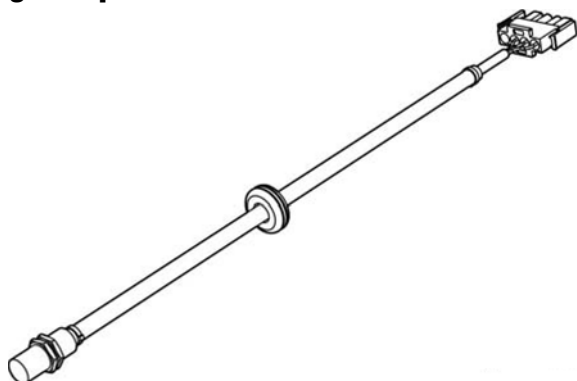

The engine speed sensor provides a signal proportional to the rotational speed of the engine to the engine/generator controller. This signal is used by the engine/generator controller to determine starter cut-out, overspeed fault and underspeed fault. If the signal is not present at the engine/generator controller, the unit will fault with a loss of speed signal indication.

The engine speed sensor is connected to the engine/generator controller at pins J2-9, J2-15 and J2-20.

The engine speed sensor is located inside the recoil starter cover at the front of the engine.

RBS Engine/Generator Controller

The control system enclosure houses the RBS engine/generator controller, which performs all control tasks associated with the RBS.

The engine/generator controller interface is via a J2 35-pin connector.

Table 3-9. Controller Interface Pin Assignments

PIN	FUNCTION
1	System 48VDC
2	System 0V DC
3	Fuel solenoid
4	Starter Solenoid
5	Manual call to start
6	Low oil pressure
7	Not used
8	Engine oil temperature
9	Speed sensing input
10	RS-232 +12V
11	RXD
12	TXD
13	LED Driver GND
14	LED Driver +48V
15	Speed sensor GND
16	Not used
17	Not used
18	- Output voltage
19	Engine oil temperature/ambient temp. + 8V
20	Speed Sensing + 8V
21	Output current sensor (GND)
22	Not used
23	RS-232 GND
24	- Field drive
25	+ Start battery
26	- Start battery
27	Pre-heat
28	Inhibit run
29	Engine temp. switch
30	+ Output voltage
31	Speed sensing + 5V
32	Output current sense
33	Not used
34	Not used
35	Field Drive

Warnings and Safety Precautions

⚠ WARNING

THE RBS MAY START WITHOUT WARNING.

⚠ WARNING

MORE THAN ONE LIVE CIRCUIT IS USED INSIDE THE RBS CONTROL PANEL. EXERCISE CAUTION WHEN THE CONTROL PANEL IS OPEN, EVEN WHEN THE RBS IS NOT RUNNING.

System Controls

INHIBIT RUN INPUT

The inhibit run input prevents the RBS from starting, clears any existing calls to start and stops the engine immediately. To return to normal operating mode, the inhibit run input must be removed.

MANUAL CALL TO START

The manual call to start input initiates an automatic run of the RBS unit.

RS232 PORT

The RS232 allows the RBS to be monitored and controlled using an analyzer.

System Status and Performance Monitoring

System status and performance can be monitored by the analyzer.

System Settings

CALL TO START SETTINGS

Low battery voltage call to start level	48.0 VDC
Low battery voltage remove call to start level	54.0 VDC
Low temperature call to start level	5°C
Low temperature remove call to start level	8°C
Low start battery voltage call to start level	12.2 V
Low start battery voltage remove call to start level	12.9 V

CURRENT AND VOLTAGE SETTINGS

Normal output voltage level	58.0 VDC
Extend output voltage level	58.0 VDC
Current limit level	45 ADC
High voltage shutdown level	63 ADC
Finish charging current level	30 ADC

TIME DELAY SETTINGS

TD engine start	30s
TD purge	0s
TD bypass	10s
TD engine run	1800s
TD cool-down	30s
TD high volts	2s

CRANK SETTINGS

Crank time	15s
Reset time	15s
Crank cycles	3

SPEED TIME AND GLOW PLUG SETTINGS

TD no speed signal	5s
TD DC sensing fault	10s
Starter disconnect	1000 Hz
Overspeed shutdown	3800 RPM
Underspeed shutdown	2000 RPM
Glow plug on temperature	5°C
Glow plug on time	15s

RBS Start

Call to start	Manual	48VDC applied to the input
	Automatic	1 Low battery voltage (below 48VDC)
		2 Low engine temperature (below 5°C)
		3 Low start battery voltage (below 12.2V)
Engine start time delay		RBS waits to verify that call to start is valid (not a transient condition).
Preheat delay		- if engine temperature is below 32°F (0°C)
Crank time (Rest time)		RBS will crank and rest until engine starts, or Overcrank fault is indicated after 3 failed crank cycles.
Time delay bypass		RBS waits until normal engine operating conditions are reached before Low oil pressure and Underspeed faults are monitored.

RBS shutdown

Call to start removed	Manually	Inhibit run input applied
	Automatically:	1 Battery voltage above 54VDC and finish charging current below 30ADC
		2 Engine temperature above 8°C
		3 Start battery voltage above 12.9V and finish charging current below 30ADC
Engine run time delay		This period ensures that no further call to start conditions occur prior to cool-down period.
Cool-down period		Alternator output is reduced to a minimal level to allow the engine to cool down.

RBS Alarms and Flash Codes

In the event of an RBS alarm, a flash code will be issued and an alarm indicated on the analyzer.

Table 3-10. RBS Alarms and Flash Codes

Flash Code	Problem		RBS Condition
1-1	Low Oil Pressure ¹	Below 7psi	Shutdown
1-2	High Engine Temp.	Over248°F(120°C)	Shutdown
1-3	Overspeed	Over 3800 RPM	Shutdown
1-4	Underspeed 1	Below 2000 RPM	Shutdown
	Overcrank	3 failed crank cycles Call to start removed	Call to start removed
1-5	No Speed Signal ²		Shutdown
2-1	Overvoltage ³	Over 63VDC	Shutdown
2-2	Engine Starting System fault 4		Alarm
2-4	Loss Of Voltage Sense	Alternator output less than 1/2 of the system nominal voltage (58VDC)	Shutdown
steady	Unit Enabled, no faults		Unit can respond to any call to start
-	Unit Off / Disabled		Unit will not respond to any call to start
Notes:			
1 Enabled once time delay bypass period has elapsed after engine startup.			
2 Delayed to ensure the fault was not momentary.			
3 Measured at the alternator output, shutdown is delayed by a factory set period to ensure the fault was not caused by a transient condition.			
4 Indicates a problem with the engine start battery, engine magneto or magneto-voltage regulator.			

Alarms must be reset once the fault has been corrected (see below).

Resetting the RBS Controller

The RBS can be reset using the analyzer or by disabling and re-enabling the RBS controller. This will clear any current fault condition with the controller.

Maintenance Schedule

- Check oil level every 24 hours
- Change engine oil and filter every 150 hours

Troubleshooting

Table 3-11. Troubleshooting

Flash Code	Problem	Solution
-	Unit Off / Disabled (engine will not crank)	<p>Check position of selector switch.</p> <p>Verify that the inhibit run is released.</p> <p>Check the warning LED. Remedy fault if present and restart the RBS.</p> <p>Check the start battery voltage.</p> <p>Check control fuse.</p> <p>Check for loose wiring or connection.</p>
1-1	Low Oil Pressure	<p>Check oil level.</p> <p>Check oil supply lines.</p> <p>Refer to Kubota Workshop manual WSM OC60/80/95.</p> <p>Verify correct operation of oil pressure switch with a test gauge.</p>
1-2	High Engine Temp.	<p>Check for obstructions in the cooling airflow to the engine.</p> <p>Check that the ambient temperature is within the design limits of the engine.</p> <p>Verify correct operation of engine temperature sensor.</p>
1-3	Overspeed	<p>Verify setting of governor lever. Readjust, if required.</p> <p>Refer to Kubota Workshop manual WSM OC60/80/95.</p>
1-4	Underspeed	<p>Ensure there is an adequate supply of fuel to the engine.</p> <p>Ensure there is an adequate supply of combustion air to the engine. Check air cleaner.</p> <p>Verify setting of governor lever. Readjust if required.</p> <p>Refer to Kubota OC60 Engine Manual.</p>
	Overcrank	<p>Check fuel level.</p> <p>Check fuel connections.</p> <p>Verify operation of fuel solenoid and fuel pump.</p> <p>Check the start battery voltage.</p> <p>If the engine exhaust contains white smoke then fuel is entering the engine but the engine is not firing. Refer to the Kubota OC60 Engine Manual for further checks.</p> <p>If the ambient temperature is low, verify that the heater and/or glow plug are operating.</p>
1-5	No Speed Signal	<p>Check wiring connections.</p>
2-1	Overvoltage	<p>Check alternator output voltage.</p>

Table 3-11. Troubleshooting

Flash Code	Problem	Solution
2-2	Engine Starting System fault	Check engine start battery charging system for current output. Check for failed engine start battery.
2-4	Loss Of Voltage Sense	

APU Engine Start Battery Boosting

Always connect the POSITIVE (+) of the booster battery to the POSITIVE (+) of the APU start battery, and the NEGATIVE (-) of the booster battery to the ground of the engine block.

WARNINGS:

⚠ WARNING

ALWAYS SHIELD YOUR EYES AND AVOID LEANING OVER THE BATTERY WHENEVER POSSIBLE.

⚠ WARNING

DO NOT ALLOW BATTERY ACID TO CONTACT EYES OR SKIN. FLUSH ANY CONTACTED AREA WITH WATER IMMEDIATELY. SEEK MEDICAL ATTENTION IF IRRITATION PERSISTS.

⚠ WARNING

STARTING BATTERIES GENERATE EXPLOSIVE GASES. KEEP SPARKS, FLAME AND LIGHTED CIGARETTES AWAY FROM BATTERIES.

⚠ WARNING

IMPROPER USE OF A BOOSTER BATTERY TO START AN APU MAY CAUSE AN EXPLOSION.

⚠ WARNING

DO NOT ATTEMPT TO JUMP START AN APU WITH A LOW ACID LEVEL IN THE BATTERY.

⚠ WARNING

THE VOLTAGE OF THE BOOSTER BATTERY MUST BE RATED AT 12V. THE AMP-HOUR CAPACITY OF THE BOOSTER BATTERY MUST NOT BE LOWER OR SUBSTANTIALLY HIGHER THAN THAT OF THE DISCHARGED BATTERY. USE OF BATTERIES OF DIFFERENT VOLTAGE OR SUBSTANTIALLY DIFFERENT AMP-HOUR RATING MAY CAUSE AN EXPLOSION OR PERSONAL INJURY. APPLYING A HIGHER VOLTAGE WHILE BOOSTING WILL ALSO CAUSE DAMAGE TO SENSITIVE ELECTRONIC COMPONENTS.

⚠ WARNING

A CHARGING SYSTEM (BATTERY CHARGER OR BATTERY CHARGING ALTERNATOR) MUST NEVER BE ENERGIZED WHILE BOOSTING. DAMAGE TO SENSITIVE ELECTRONIC COMPONENTS WILL RESULT.

⚠ CAUTION

THE MAIN BATTERY OF THE LIFT MUST NEVER BE USED TO BOOST THE APU. DAMAGE TO SENSITIVE ELECTRONIC COMPONENTS WILL RESULT.

3.14 SUPPLEMENTARY FUSE FOR APU

The purpose of this section is to describe the procedure to add a supplementary fuse for the Engine Generator Controller for the APU.

Tools And Material

- - Weather proof fuse holder - JLG P/N 2400081
- - AGC1, 1 Amp fuse - JLG P/N 2400080
- - 45 cm of #16 AWG wire - JLG P/N 4920019
- - 2 X insulated butt splice connectors - JLG P/N 4460035
- - 6 X medium length wire ties - JLG P/N 4240033
- - Wire/Side cutters
- - 5/32" Allen Key
- - Crimping tool

Procedure

⚠ WARNING

BEFORE BEGINNING THIS PROCEDURE, ENSURE THAT ALL SOURCES OF POWER ARE DISCONNECTED FROM THE APU!

This procedure is common for all applications of the APU. The photos contained in this document illustrate the modification performed to an APU supplied in a JLG M450 lift.

1. Locate the harness at the rear of the APU.



that the cable sleeve can be moved, exposing the

2. Find where the harness attaches to the rear cover of the generator and the connection point for the new inline fuse.



3. Remove the socket head drive screw with a 5/32" Allen key. Next remove the cable clamp from the harness.



4. Cut and remove the Wire Ties holding the Harness label to the harness. Next, remove the Wire Ties so

conductors of the harness.



5. Cut wire 106 going to the Engine/Generator Controller after the existing connection point and install the conductors that lead to the new inline fuse holder. Use insulated butt splice connectors for these conductors.



6. Re-install the harness with the new fuse in place.

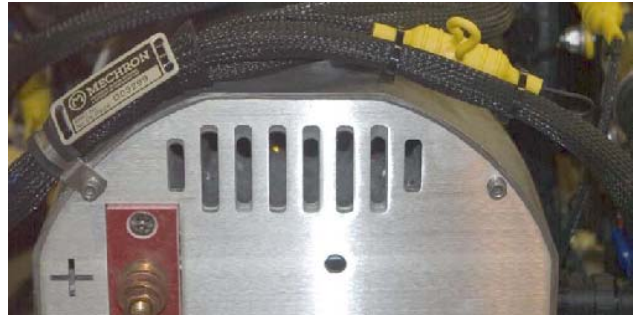

7. Reconnect the lift and APU start battery. The APU is now ready for use.

SECTION 4. BOOM & PLATFORM

4.1 BOOM MAINTENANCE

Removal

1. Remove the platform/support as follows:
 - a. Disconnect electrical cable from control console.
 - b. Using an overhead crane or suitable lifting device, strap support the platform/support.
 - c. Remove hardware from pin #1. Using a suitable brass drift and hammer, remove pin #1 from the platform support.
 - d. Supporting the platform/support, remove the hardware from pin #2. Using a suitable brass drift and hammer, remove pin #2 from the fly boom and remove the rotator.
 - e. Supporting the slave cylinder, remove the hardware from pin #3. Using a suitable brass drift and hammer, remove pin #3 from the fly boom.
 - f. Tag and disconnect hydraulic lines to the slave leveling cylinder. Use a suitable container to retain any residual hydraulic fluid. Cap hydraulic lines and ports. Remove the slave cylinder.
2. Remove the boom from upright as follows:
 - a. Remove hardware securing the cover plate on the side of the base boom section and remove hose clamps. Disconnect wiring harness from ground control harness connector.

CAUTION

HYDRAULIC LINES AND PORTS SHOULD BE CAPPED IMMEDIATELY AFTER DISCONNECTING LINES TO AVOID ENTRY OF CONTAMINANTS INTO SYSTEM.

- b. Tag and disconnect hydraulic lines from boom to control valve. Use a suitable container to retain any residual hydraulic fluid. Cap hydraulic lines and ports.
- c. Using a suitable lifting equipment, adequately support boom weight along entire length.
- d. Remove hardware securing the lift cylinder pin #1. Using a suitable brass drift and hammer, remove pin #1 from the base boom.

- e. Remove hardware securing the master cylinder pin #2. Using a suitable brass drift and hammer, remove pin #2 from the base boom.
- f. Remove hardware securing the base boom pin #3. Using a suitable brass drift and hammer, remove pin #3 from the upright.
- g. Using all applicable safety precautions, carefully lift boom assembly clear of upright and lower to ground or suitable supported work surface.

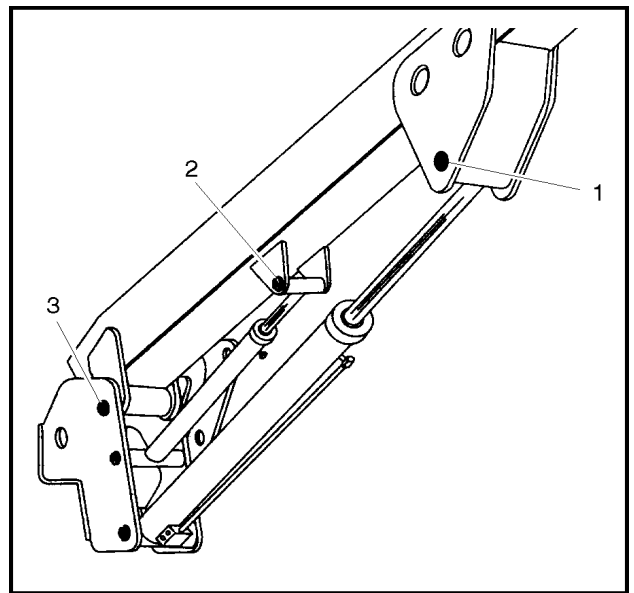

Figure 4-1. Location of Components - Boom Removal

Disassembly

1. Loosen jam nuts on aft end of fly boom wear pad adjustment and loosen adjustments.
2. Using a portable power source, attach hose to telescope cylinder port block. Using all applicable safety precautions, activate hydraulic system and extend cylinder to gain access to cylinder rod pin #1. Shut down hydraulic system.
3. Carefully disconnect hydraulic hose from retract port of cylinder. There will be initial weeping of hydraulic fluid which can be caught in a suitable container. After initial discharge, there should be no further leakage from the retract port.

4. Remove hardware securing telescope cylinder #1 to the fly boom section, then remove pin from fly.
5. Remove hardware securing telescope cylinder to the base boom section.

⚠ CAUTION

WHEN REMOVING TELESCOPE CYLINDER FROM BOOM SECTIONS. CARE SHOULD BE TAKEN NOT TO LET CYLINDER REST ON POWERTRACK WHICH COULD CAUSE DAMAGE TO POWERTRACK.

6. Using a suitable lifting device, remove telescope cylinder from boom sections.
7. Using a piece of tape, mark the length of hoses and wires from front of fly boom and bottom of base boom for reassembly.
8. Remove hardware securing the front cover on base boom section.
9. Loosen jam nuts on front wear pad adjustments and loosen adjustments.
10. Remove hardware securing the front wear pads on base boom section, remove wear pads.
11. Remove wire clamp on the inside of the fly nose.
12. Manually push the fly boom section into base boom section to gain access to the power track attachment bolts on the right side of the base boom section.
13. Remove hardware securing the power track to the aft end of the fly boom section.
14. Using a suitable lifting device, remove fly boom from boom section.
15. Remove hydraulic lines and electrical cables from power track.
16. Remove hardware securing power track to the base boom section. Remove power track.

Inspection

1. Inspect boom pivot pin for wear, scoring or other damage, and for tapering or ovality. Replace pin as necessary.
2. Inspect lift and master cylinder pins for wear, scoring or other damage, and for tapering or ovality. Ensure pin surfaces are protected prior to installation. Replace pins as necessary.
3. Inspect telescope cylinder rod attach pin for wear, scoring or other damage. Replace pin as necessary.
4. Inspect inner diameter of boom pivot bushings for scoring, distortion, wear or other damage. Replace bushings as necessary.
5. Inspect wear pads for wear as shown in Section 4.7, Wear Pads.
6. Inspect all threaded components for damage such as stretching, thread deformation, or twisting. Replace as necessary.
7. Inspect structural units of boom assembly for bending, cracking, separation of welds, or other damage. Replace boom sections as necessary.

Assembly

1. Install power track to the attach point on the inside of the base boom section. Secure power track with hardware.
2. Install hydraulic lines and electrical cables into the power track.
3. Install wear pads to the aft end of the fly section.
4. Using suitable lifting equipment, slide fly section into the base section until power track attach point aligns with holes in side of base section.
5. Attach the power track to the aft end of fly boom section. Secure power track with hardware.

6. Using suitable lifting equipment, slide fly boom section out to gain access to telescope cylinder attach pin hole.
7. Measure the distance between the telescope cylinder port block attach point on base boom section and the attach point on fly boom section.
8. Connect a suitable auxiliary hydraulic power source to the telescope cylinder port block.
9. Extend the telescope cylinder the distance of the two attach points.
10. Secure the sling and lifting device at the telescope cylinder's approximate center of gravity, and lift the cylinder to the aft end of the boom assembly.

⚠ CAUTION

WHEN INSERTING THE TELESCOPE CYLINDER INTO THE BOOM, CARE MUST BE TAKEN NOT TO DAMAGE THE POWER TRACK ASSEMBLY.

11. Slowly slide the telescope cylinder into boom assembly, align rod end with attach point in fly section. Insert pin and secure with retaining ring.
12. Align bolt holes at aft end of base boom section with telescope cylinder port block. Secure telescope cylinder with hardware.
13. Install wear pads at end of base boom section. Adjust the adjustable wear pads to zero clearance. Adjust pads alternately side to side, so that fly boom section is centered in base boom section.
14. Retract boom section fully. Adjust wear pads at aft end of boom section to zero clearance. Adjust pads alternately side to side, so that fly boom section is centered in base boom section.
15. Disconnect auxiliary power source from telescope cylinder.

Installation

1. Using suitable lifting equipment, position boom assembly on upright so that boom pivot holes in both boom and upright are aligned.
2. Install boom pivot pin, ensuring that location of the hole in pivot pin aligns with attach point on upright.
3. Using all applicable safety precautions, operate lifting equipment in order to position boom lift and master cylinders so that holes in cylinder rod ends and boom structure are aligned. Insert cylinder pins.
4. If necessary, gently tap pins into position with a soft headed mallet, ensuring that attach holes in pins are aligned with attach holes in boom structure. Secure with hardware.
5. Connect all hosing and wiring.
6. Install the slave leveling cylinder to the boom assembly.
7. Install the platform to the boom assembly.
8. Connect all hosing and wiring at platform control station.
9. Using all safety precautions, operate machine systems and extend and retract boom for four or five cycles.
10. Shut down machine systems and check for leakage.

4.2 UPPER (MAIN) BOOM LIFT CYLINDER

Removal

1. Place the machine on a flat and level surface. Place the Upper Boom in a horizontal position. Place Lower and Mid Booms 5 degree above horizontal. Shut down machine and prop boom.
2. Tag, disconnect and cap the upper boom lift cylinder hydraulic lines and ports.
3. Remove the hardware securing the cylinder rod attach pin #1 to the boom. Using a suitable brass drift, drive out the cylinder rod attach pin #1

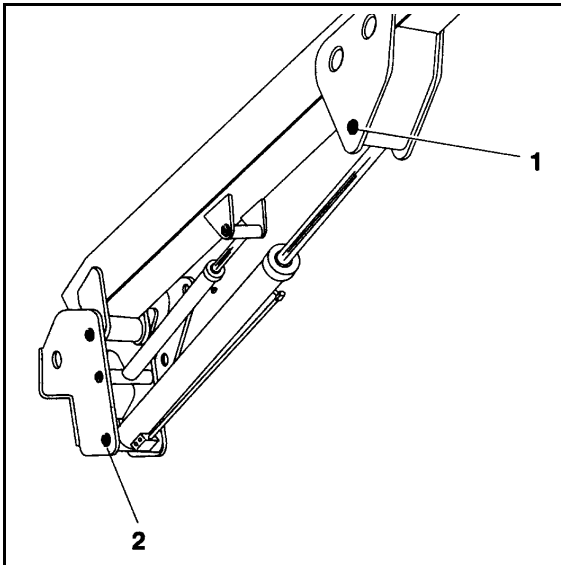

Figure 4-2. Upper Boom Lift Cylinder Removal

4. Secure the cylinder with suitable slings or supports as required. Remove the hardware securing the barrel end attach pin #2. Using a suitable brass drift, drive out the barrel end attach pin #2.
5. Remove the cylinder from the boom and place in a suitable work area.

Installation

NOTE: Coat I.D. of bushings with specified lubricant prior to installing pins.

1. Install Lift Cylinder in place using suitable slings or supports, aligning attach pin mounting holes on upright.
2. Using a suitable drift, drive the barrel end attach pin #2 through the mounting holes in the lift cylinder and upright. Secure in place with pin retaining hardware.

3. Remove cylinder port plugs and hydraulic line caps and correctly attach lines to cylinder ports.
4. With function speed switch at its slowest setting, extend the cylinder rod until attach pin hole aligns with those in boom. Using a suitable drift, drive the cylinder rod attach pin #1 through the aligned holes. Secure the pin in place with pin retaining hardware.
5. Cycle cylinder completely to check for proper functioning. Place boom in stowed position. Check hydraulic fluid level and adjust accordingly.

4.3 MID BOOM LIFT CYLINDER

Removal

1. Place machine on flat and level surface. Place the Upper Boom in a horizontal position. Place the Mid Boom in a 10 degree elevated position. Support Upper Boom with a prop. Support upright with an overhead crane.
2. Using slings, restrain the lower lift cylinder.
3. Remove the hardware securing the cylinder rod attach pin #3 to the boom. Using an appropriate brass drift, drive out the cylinder rod attach pin #3.

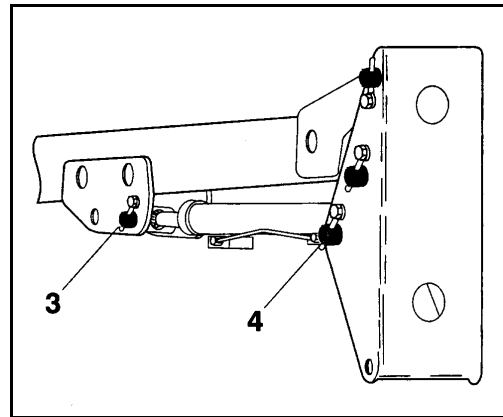

Figure 4-3. Mid Boom Lift Cylinder Removal

4. Tag, disconnect and cap the lift cylinder hydraulic lines and ports.
5. Remove the hardware securing the barrel end attach pin #4 to the boom. Using an appropriate brass drift, drive out the cylinder barrel pin #4.
6. Carefully remove cylinder from boom. Place in a suitable work area.

Installation

NOTE: Coat I.D. of bushings with specified lubricant prior to installing pins.

1. With the booms positioned and supported, place cylinder in position and secure in place using slings.
2. Install the cylinder barrel pin #4, being sure to align the hole in the cylinder barrel pin with the retaining pin screw hole. When holes align, install hardware.
3. Correctly install hydraulic lines to cylinder as previously tagged. Extend cylinder rod slowly until attach pin hole aligns with those in boom.
4. Using a suitable brass drift, drive the cylinder rod attach pin #3 through the aligned holes. Secure the pin in place using retaining hardware.
5. Remove boom prop and overhead crane. Take the lift cylinder through one complete cycle to assure correct functioning. Place boom in stowed position. Check hydraulic fluid and adjust accordingly.

3. Remove the hardware securing the cylinder rod attach pin #5 to the boom. Using an appropriate brass drift, drive out the cylinder rod attach pin #5.

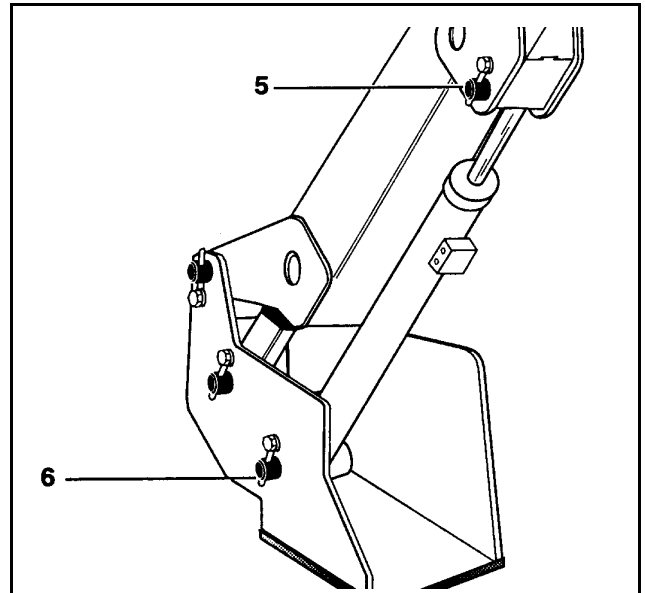

Figure 4-4. Lower Boom Lift Cylinder Removal

4.4 LOWER BOOM LIFT CYLINDER

Removal

1. Place machine on flat and level surface. Place the Upper Boom in a horizontal position. Place the Mid and Lower Booms in a 10 degree elevated position. Support Upper Boom with a prop. Support upright with an overhead crane.
2. Using slings, restrain the lower lift cylinder.

4. Tag, disconnect and cap the lift cylinder hydraulic lines and ports.
5. Remove the hardware securing the barrel end attach pin #6 to the boom. Using an appropriate brass drift, drive out the cylinder barrel pin #6.
6. Carefully remove cylinder from boom. Place in a suitable work area.

Installation

NOTE: Coat I.D. of bushings with specified lubricant prior to installing pins.

1. With the booms positioned and supported, place cylinder in position and secure in place using slings.
2. Install the cylinder barrel pin #6, being sure to align the hole in the cylinder barrel pin with the retaining pin screw hole. When holes align, install hardware.
3. Correctly install hydraulic lines to cylinder as previously tagged. Extend cylinder rod slowly until attach pin hole aligns with those in boom.
4. Using a suitable brass drift, drive the cylinder rod attach pin #5 through the aligned holes. Secure the pin in place using retaining hardware.
5. Remove boom prop and overhead crane. Take the lift cylinder through one complete cycle to assure correct functioning. Place boom in stowed position. Check hydraulic fluid and adjust accordingly.

4.5 UPPER BOOM TELESCOPE CYLINDER

Removal

1. Place machine on flat and level surface, with Upper Boom in the horizontal position. Extend Upper Boom until fly attach pin #1 is accessible on fly.

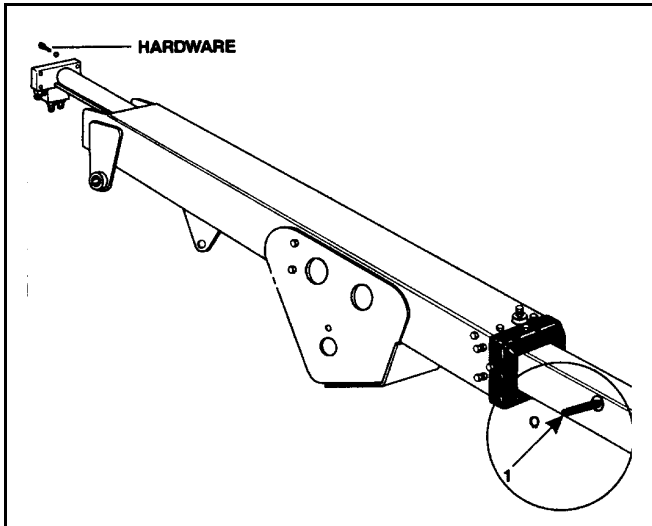

Figure 4-5. Upper Telescope Cylinder Removal

2. Support Upper Boom basket end with a prop. Support Upper Upright end with an overhead crane.
3. Tag, disconnect hydraulic lines to telescope cylinder. Use suitable container to retain any residual hydraulic fluid. Cap hydraulic lines and ports.
4. Remove the retaining rings that retain the telescope cylinder rod to the fly boom.
5. Using a suitable brass drift, carefully drive the telescope cylinder rod pin #1 from the fly boom.

6. Remove the four (4) bolts securing the telescope cylinder barrel end to the base boom.

NOTE: Care should be taken when removing the telescope cylinder, do not leave cylinder rest on power track which could cause damage to power track.

7. Using a suitable brass drift, carefully drive the telescope cylinder pin from the base boom.
8. Attach a suitable sling to the telescope cylinder. Using a suitable lifting device attached to the sling carefully pull the telescope cylinder from the boom assembly.
9. Using another lifting device, support the rod end of the cylinder and remove the cylinder from the boom assembly.
10. Carefully lift the cylinder clear of the boom assembly and lower to the ground or suitably supported work area.

Installation

1. Attach a hydraulic power supply to the telescope cylinder ports. Using suitable supports or lifting devices at each end of the cylinder, extend the rod so that the cylinder pin attach holes are the same distance apart as the boom pin attach holes.
2. Using suitable lifting equipment, carefully lower the cylinder to the boom assembly.
3. Using another lifting device, support the rod end of the cylinder and install the cylinder into the boom assembly.
4. Remove lifting devices from the telescope cylinder.
5. Carefully install the telescope cylinder rod pin #1 through the fly boom and secure it with the retaining rings.

6. Carefully install the telescope cylinder barrel end to base, securing cylinder to the base boom with four (4) bolts and hardware.
7. Remove applicable hydraulic line and port caps and correctly connect the hydraulic lines to the telescope cylinder. Ensure all hoses are correctly routed.
8. Remove boom prop and overhead crane. Activate hydraulic system.
9. Using all applicable safety precautions, operate the boom functions. Check for correct operation and hydraulic leaks. Secure as necessary.
10. Check fluid level of hydraulic tank and add as necessary.

4.6 MID AND LOWER LIFT CYLINDER BLEEDING PROCEDURE

NOTE: Bleeding procedure should only be necessary if rebuilding or replacing lift cylinder.

1. Check oil level in the hydraulic oil tank (all booms must be retracted).
2. Lay an oil drip pan under the rod end port block (Mid Cylinder) and crack bleeder open from the fitting in the port block.
3. From the platform, turn the speed control knob to the slow position.
4. Lift up very slowly. This will force any air out of the circuit. If the lower boom is not extending, turn the speed control up very slowly until the lower boom starts to move.
5. Raise the lower boom approximately 30.5 cm (1 foot), then close bleeder while the boom is still moving.
6. Lift down all the way.
7. Repeat this procedure until all air has been purged from the circuit. Re-check the hydraulic oil level.
8. To test, cycle the lower lift function 3-4 times to see if both cylinders stop at the same time when fully extended.

4.7 WEAR PADS

1. Shim up wear pads until snug to adjacent surface.
2. Replace wear pads when worn to thickness shown below

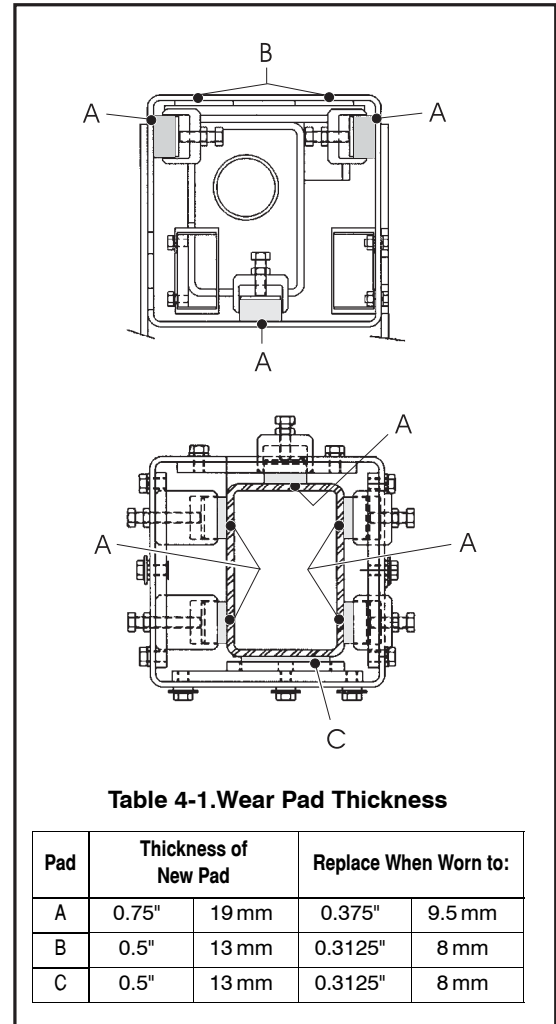

Figure 4-6. Wear Pad Thickness

3. Adjust wear pads as follows:
 - a. Loosen jam nut on adjustment bolt, turn bolt CW until wear pad is snug to adjacent surface.
 - b. After adjustments have been made, tighten the jam nuts on wear pad bolts.

4.8 BOOM SYNCHRONIZING PROCEDURE

NOTE: If the Lower Boom assembly does not fully lower:

1. Remove all personnel from the platform.
2. Pull the red knob located under the main control valve.
3. From Ground Control, activate the lift control switch, raise Lower Boom 6 feet (1.8m).
4. After raising Lower Boom, release the red knob.
5. Activate Lower Boom Down, fully lower boom.
6. Repeat step 1 thru 5 if necessary.

4.9 ARTICULATING JIB BOOM

Removal

1. For platform/support removal see platform/support removal diagram. See Section 4.1, Boom Maintenance.
2. Position the articulating jib boom level with ground.
3. Remove mounting hardware from slave leveling cylinder pin #1. Using a suitable brass drift and hammer, remove the cylinder pin from articulating jib boom.

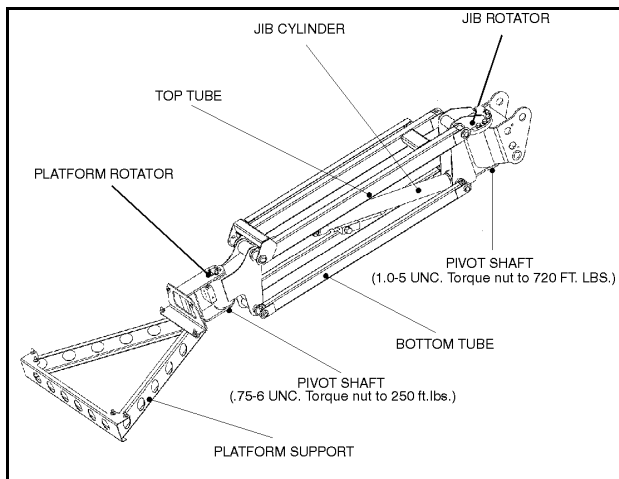

Figure 4-7. Location of Components - Articulating Jib Boom

4. Remove mounting hardware from articulating jib boom pivot pin #2. Using a suitable brass drift and hammer, remove the pivot pin from boom assembly.

Disassembly

1. Remove mounting hardware from articulating jib boom pivot pins #3 and #4. Using a suitable brass drift and hammer, remove the pins from articulating jib boom pivot weldment.
2. Remove mounting hardware from rotator support and jib lift cylinder pins #5 and #6. Using a suitable brass drift and hammer, remove the pins from rotator support.

Inspection

1. Inspect articulating fly boom pivot pin for wear, scoring, tapering and ovality, or other damage. Replace pins as necessary.
2. Inspect articulating fly boom pivot attach points for scoring, tapering and ovality, or other damage. Replace pins as necessary.
3. Inspect inner diameter of articulating fly boom pivot bearings for scoring, distortion, wear, or other damage. Replace bearings as necessary. (See Cylinder repair For Bearing Replacement).
4. Inspect lift cylinder attach pin for wear, scoring, tapering and ovality, or other damage. Ensure pin surfaces are protected prior to installation. Replace pins as necessary.
5. Inspect inner diameter of rotator attach point bearings for scoring, distortion, wear, or other damage. Replace bearing as necessary. (See Cylinder repair For Bearing Replacement).
6. Inspect all threaded components for damage such as stretching, thread deformation, or twisting. Replace as necessary.
7. Inspect structural units of articulating jib boom assembly for bending, cracking, separation of welds, or other damage. Replace boom sections as necessary.

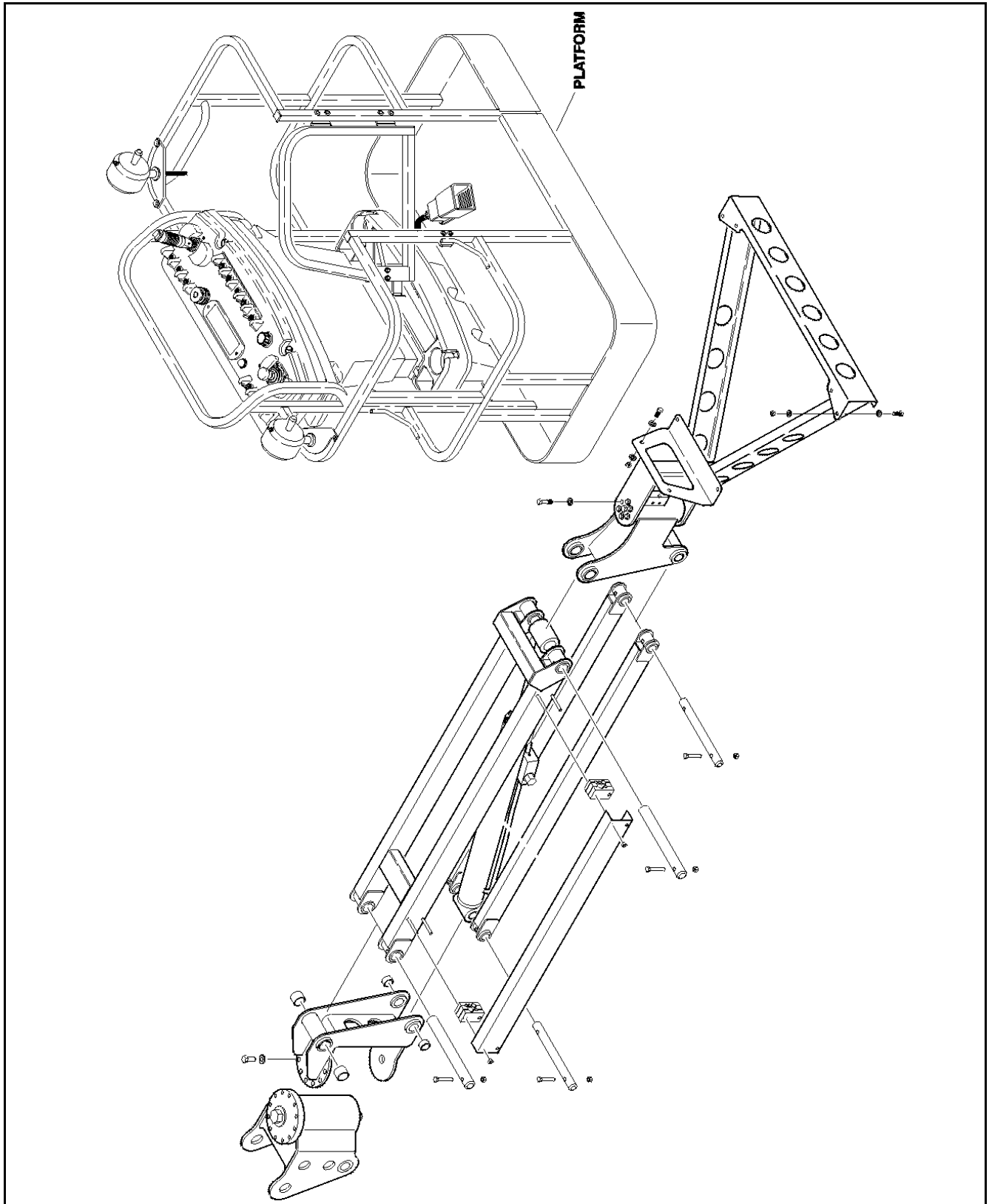

Figure 4-8. Jib/Platform Components and Attaching Hardware

Assembly

NOTE: For location of components See Section 4-7., Location of Components - Articulating Jib Boom.

1. Align lift cylinder, rotator support top tube holes, and top tubes. Using a soft head mallet, install cylinder pin #6 into articulating jib boom and secure with mounting hardware.
2. Align bottom tubes with attach holes in rotator support. Using a soft head mallet, install rotator support pin #5 into articulating jib boom and secure with mounting hardware.
3. Align articulating jib boom with attach hole in articulating jib boom pivot weldment. Using a soft head mallet, install rotator support pin #4 into articulating jib boom and secure with mounting hardware.
4. Align bottom tubes with attach holes in articulating jib boom pivot weldment. Using a soft head mallet, install rotator support pin #3 into articulating jib boom pivot weldment and secure with mounting hardware.

5. Align articulating jib boom pivot weldment with attach holes in fly boom assembly. Using a soft head mallet, install pivot pin #2 into fly boom assembly and secure with mounting hardware.
6. Align the slave leveling cylinder with attach holes in articulating jib boom pivot weldment. Using a soft head mallet, install slave leveling cylinder pin #1 into articulating jib boom pivot weldment and secure with mounting hardware.

4.10 FOOTSWITCH ADJUSTMENT

Adjust switch so that functions will operate when pedal is at center of travel. If switch operates within last 1/4 inch (6.35 mm) of travel, top or bottom, it should be adjusted.

4.11 BOOM LIMIT SWITCHES

Refer to Figure 4-10., Boom Limit Switches for adjustments to be made to the two Boom Limit Switches which bolt in place on the upright.

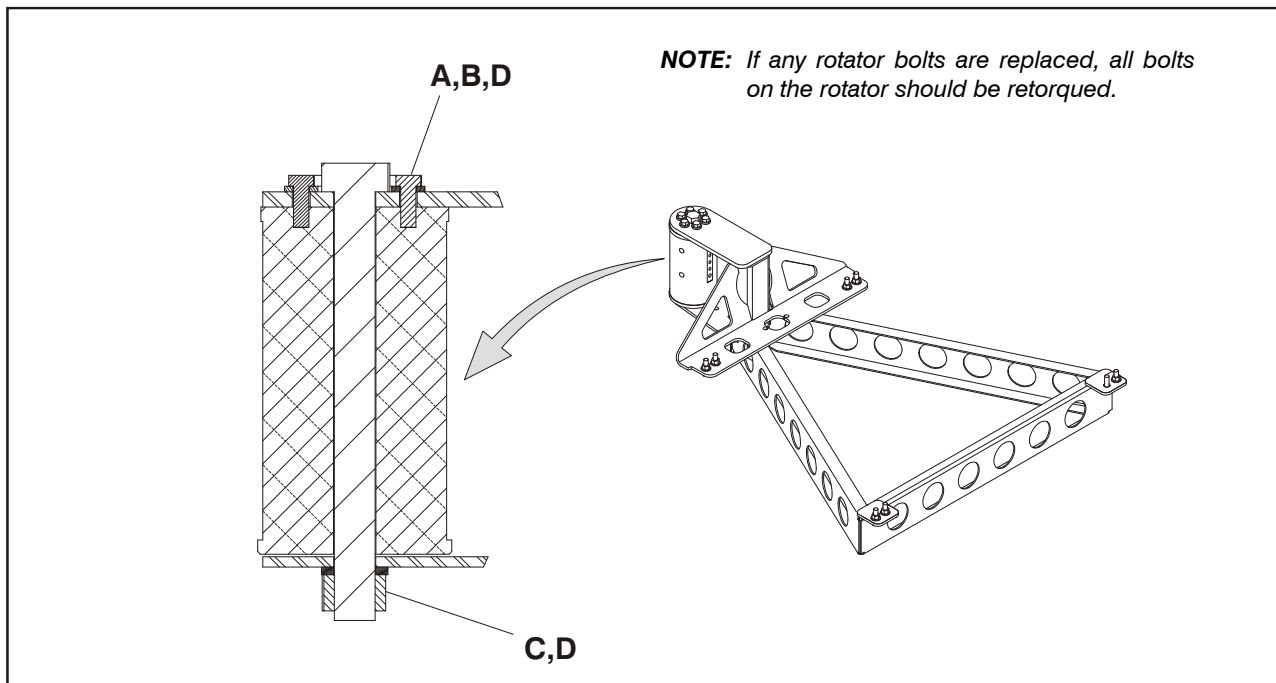

- A Torque to 50 ft.lbs. (68 Nm)
- B Loctite #242
- C Torque 250-270 ft. lbs. (339-366 Nm)
- D Check torque every 150 hours of operation

Figure 4-9. Platform Support Torque Values

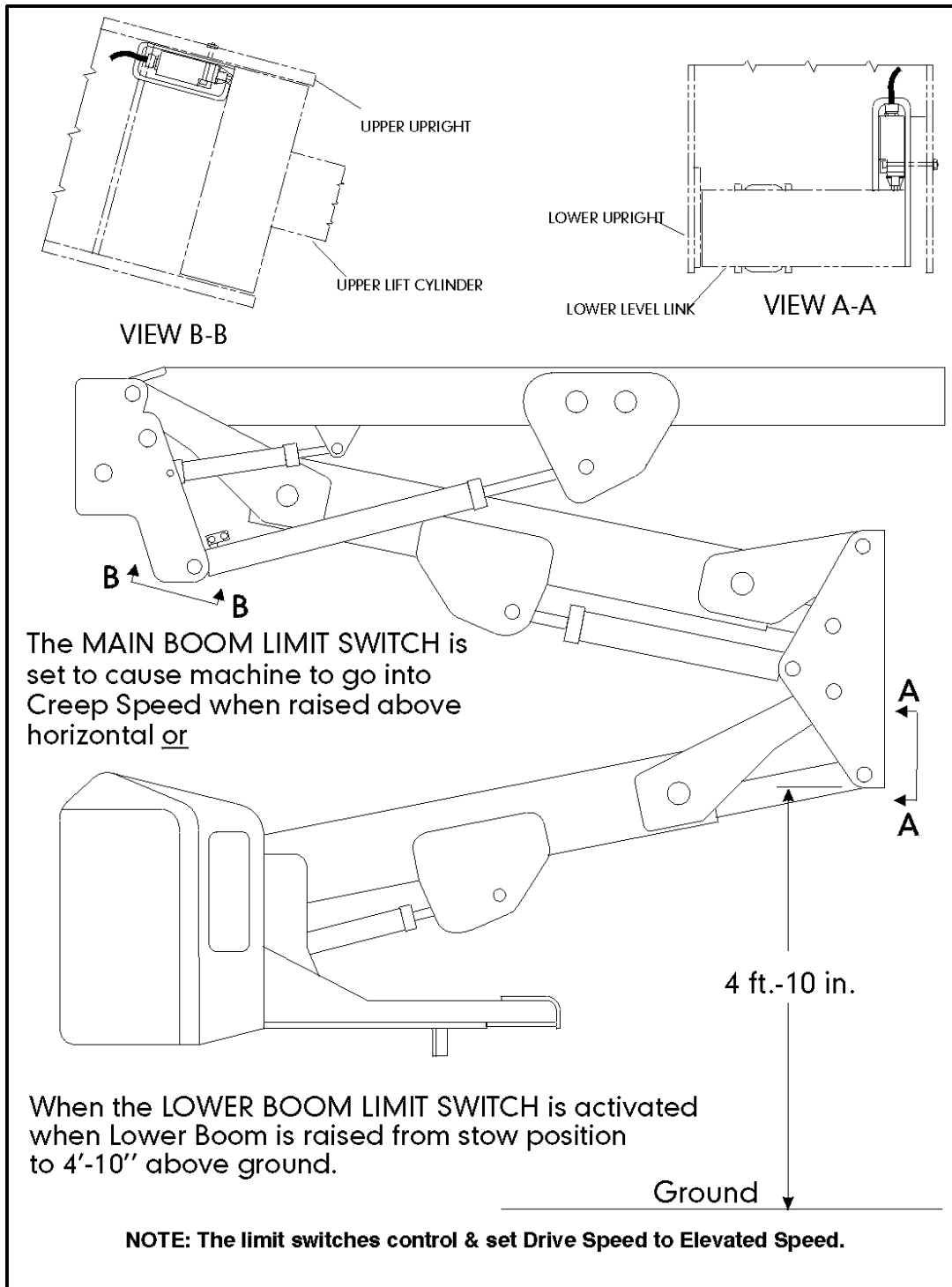

Figure 4-10. Boom Limit Switches

4.12 HELAC ROTARY ACTUATOR

Theory Of Operation

The rotary actuator is a simple mechanism that uses the sliding spline operating concept to convert linear piston motion into powerful shaft rotation. Each actuator is composed of a housing with integrated gear teeth (01) and only two moving parts: the central shaft with integrated bearing tube and mounting flange (02), and the annular piston sleeve (03). Helical spline teeth machined on the shaft engage matching splines on the in-side diameter of the piston. The outside diameter of the piston carries a second set of splines, of opposite hand, which engage with matching splines in the housing. As hydraulic pressure is applied, the piston is displaced axially within the housing -similar to the operation of a hydraulic cylinder while the splines cause the shaft to rotate. When the control valve is closed, oil is trapped inside the actuator, preventing piston movement and locking the shaft in position.

The shaft is supported radially by the large upper radial bearing and the lower radial bearing. Axially, the shaft is separated from the housing by the upper and lower thrust washers. The end cap is adjusted for axial clearance and locked in position by set screws or pins.

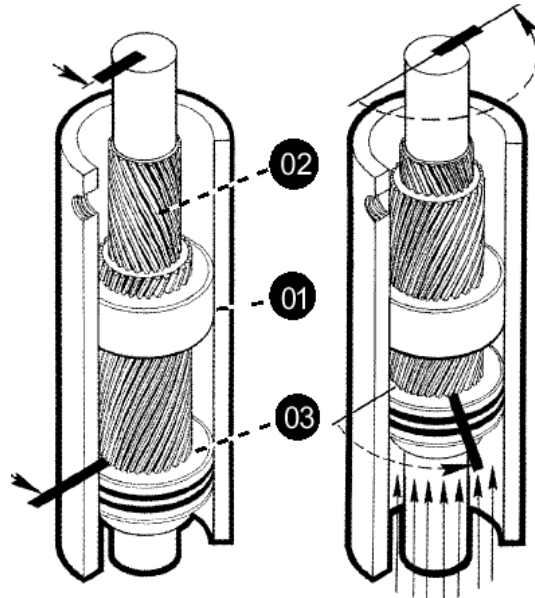

NOTE: Bars indicate starting positions of piston and shaft. Arrows indicate direction they will rotate. The housing with integral ring gear remains stationary. As fluid pressure is applied, the piston is displaced axially while the helical gearing causes the piston and shaft to rotate simultaneously. The double helix design compounds rotation: shaft rotation is about twice that of the piston.

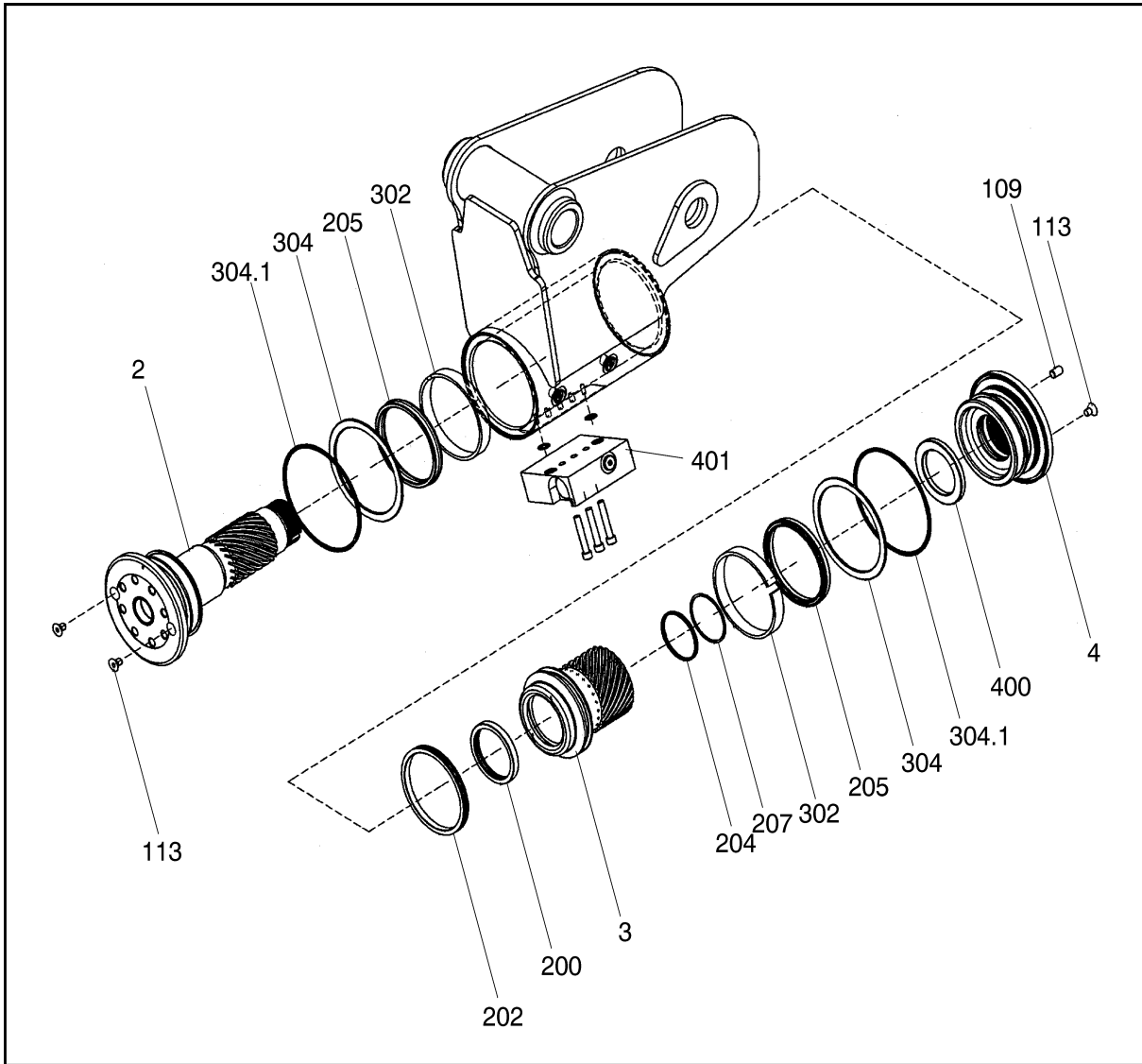

- | | | |
|------------------|-----------------|---------------------------|
| 1. Housing | 200. T-Seal | 304. Thrust Washer |
| 2. Shaft | 202. T-Seal | 304.1. Wiper Seal |
| 3. Piston Sleeve | 204. O-Ring | 400. Stop Tube (Optional) |
| 4. End Cap | 205. Cup Seal | 401. Counterbalance Valve |
| 109. Lock Pin | 207. Back-Up | |
| 113. Cap Screw | 302. Wear Guide | |

Figure 4-11. Rotary Actuator (Exploded View)

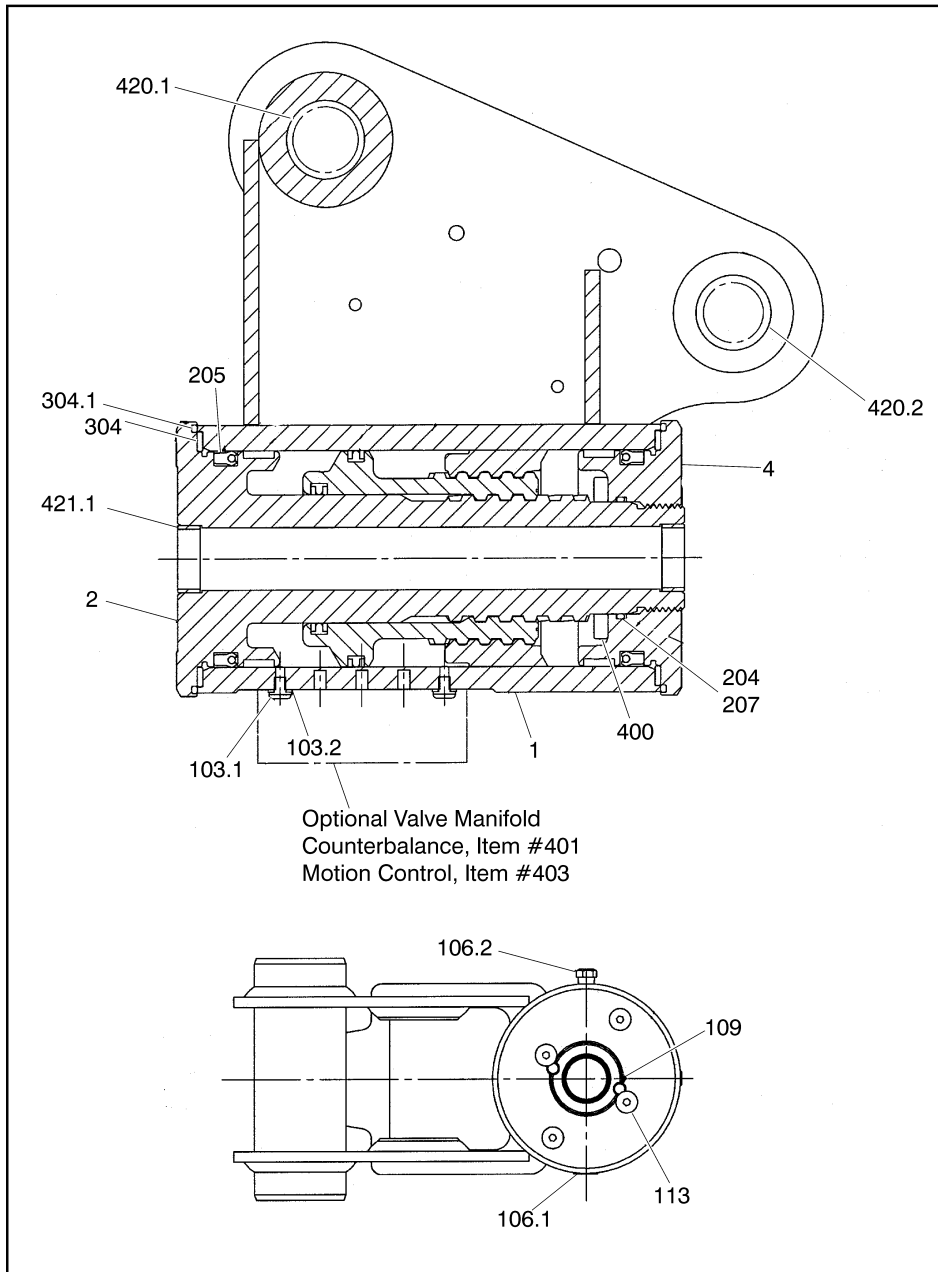

- | | | |
|------------------|-----------------|---------------------------|
| 1. Housing | 200. T-Seal | 304. Thrust Washer |
| 2. Shaft | 202. T-Seal | 304.1. Wiper Seal |
| 3. Piston Sleeve | 204. O-Ring | 400. Stop Tube (Optional) |
| 4. End Cap | 205. Cup Seal | 401. Counterbalance Valve |
| 109. Lock Pin | 207. Back-Up | |
| 113. Cap Screw | 302. Wear Guide | |

Figure 4-12. Rotary Actuator (Cutaway View)

Tools Required for Assembly/Disassembly

Upon assembly and disassembly of the actuator there are basic tools required. The tools and their intended functions are as follows:

1. Flashlight- helps examine timing marks, component failure and overall condition.
2. Felt Marker- mark the timing marks and outline troubled areas.
3. Allen wrench- removal of port plugs and setscrews.
4. Box knife- removal of seals.
5. Seal tool- assembly and disassembly of seals and wear guides.
6. Pry bar- removal of end cap and manual rotation of shaft.
7. Rubber mallet- removal and installation of shaft and piston sleeve assembly.
8. Nylon drift- installation of piston sleeve.
9. End cap dowel pins- removal and installation of end cap (sold with Helac seal kit).



The seal tool is merely a customized standard flat head-screwdriver. To make this tool you will need to heat the flat end with a torch. Secure the heated end of the screwdriver in a vice and physically bend the heated end to a slight radius. Once the radius is achieved round off all sharp edges of the heated end by using a grinder. There may be some slight modifications for your own personal preference.

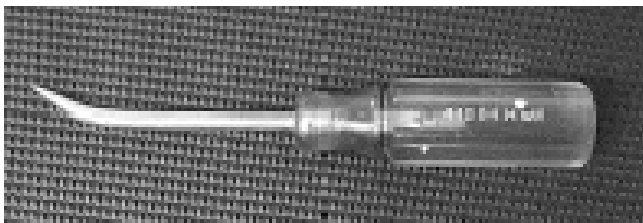

Disassembly

1. Remove the cap screws (113) over end cap lock pins (109).



2. Using a 1/8" (3.18mm) drill bit, drill a hole in the center of each lock pin to a depth of approximately 3/16" (4.76mm).



3. Remove the lock pins using an "Easy Out" (a size #2 is shown). If the pin will not come out with the "Easy Out", use 5/16" drill bit to a depth of 1/2" (12.7mm) to drill out the entire pin.



SECTION 4 - BOOM & PLATFORM

4. Install the end cap (4) removal tools provided with the Helac seal kit.



5. Using a metal bar, or something similar, un-screw the end cap (4) by turning it counter clock-wise.



6. Remove the end cap (4) and set aside for later inspection.



7. Remove the stop tube if included. The stop tube is an available option to limit the rotation of the actuator.



8. Every actuator has timing marks for proper engagement.

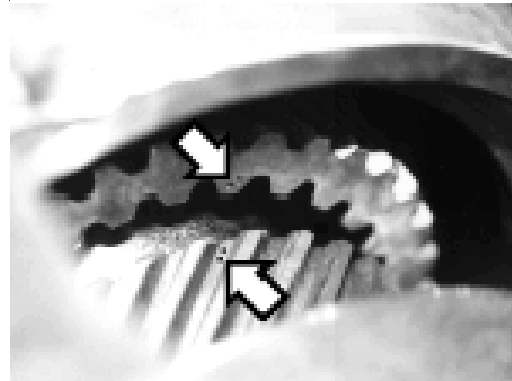
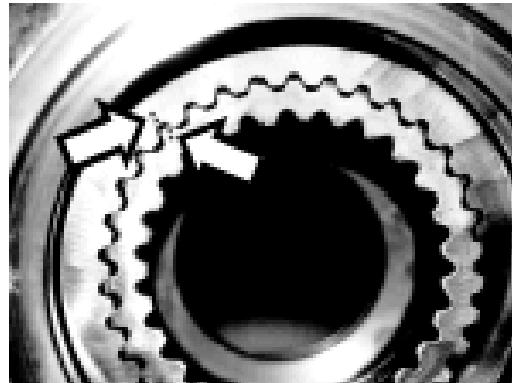

9. Prior to removing the shaft, (2), use a felt marker to clearly indicate the timing marks between shaft and piston. This will greatly simplify timing during assembly.



10. Remove the shaft (2). It may be necessary to strike the threaded end of the shaft with a rubber mallet.



11. Before removing the piston (3), mark the housing (1) ring gear in relation to the piston O.D. gear. There should now be timing marks on the housing (1) ring gear, the piston (3) and the shaft (2).



12. To remove the piston (3) use a rubber mallet and a plastic mandrel so the piston is not damaged.



13. At the point when the piston gear teeth come out of engagement with the housing gear teeth, mark the piston and housing with a marker as shown.



14. Remove the o-ring (204) and backup ring (207) from end cap (4) and set aside for inspection.



SECTION 4 - BOOM & PLATFORM

15. Remove the wear guides (302) from the end cap (4) and shaft (2).



18. Remove the wiper seal (304.1) from its groove in the end cap (4) and shaft (2).



16. To remove the main pressure seals (205), it is easiest to cut them using a sharp razor blade being careful not to damage the seal groove.



19. Remove the piston O.D. seal (202).



17. Remove the thrust washers (304), from the end cap (4) and shaft (2).



20. Remove the piston I.D. seal (200). You may now proceed to the inspection process.



Inspection

1. Clean all parts in a solvent tank and dry with compressed air prior to inspecting. Carefully inspect all critical areas for any surface finish abnormalities: Seal grooves, bearing grooves, thrust surfaces, rod surface, housing bore and gear teeth.



2. Inspect the thrust washers (304) for rough or worn edges and surfaces. Measure it's thickness to make sure it is within specifications (Not less than 0.092" or 2.34 mm).

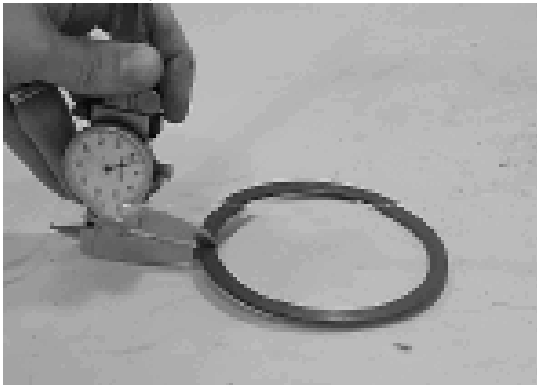

3. Inspect the wear guide condition and measure thickness (not less than 0.123" or 3.12 mm).



Assembly

1. Gather all the components and tools into one location prior to re-assembly. Use the cut away drawing to reference the seal orientations.



2. Install the thrust washer (304) onto shaft (2) and end cap (4).



3. Install the wiper seal (304.1/green O-ring) into it's groove on the shaft (2) and end cap (4) around the outside edge of the thrust washer (304).



SECTION 4 - BOOM & PLATFORM

- Using a seal tool install the main pressure seal (205) onto shaft (2) and end cap (4). Use the seal tool in a circular motion.



- Install the wear guide (302) on the end cap (4) and shaft (2).



- Install the inner T-seal (200) into the piston (3) using a circular motion. Install the outer T-seal (202) by stretching it around the groove in a circular motion. Each T-seal has 2 back-up rings (see drawing for orientation).



- Beginning with the inner seal (200) insert one end of b/u ring in the lower groove and feed the rest in using a circular motion. Make sure the wedged ends overlap correctly. Repeat this step for the outer seal (202).



- Insert the piston (3) into the housing (1) as shown, until the outer piston seal (202) is touching inside the housing bore.



- Looking from the angle shown, rotate the piston (3) until the marks you put on the piston and the housing (1) during disassembly line up as shown. Using a rubber mallet, tap the piston into the housing up to the point where the gear teeth meet.



- 10.** Looking from the opposite end of the housing (1) you can see if your timing marks are lining up. When they do, tap the piston (3) in until the gear teeth mesh together. Tap the piston into the housing the rest of the way until it bottoms out.



- 11.** Install the shaft (2) into the piston (3). Be careful not to damage the seals. Do not engage the piston gear teeth yet.

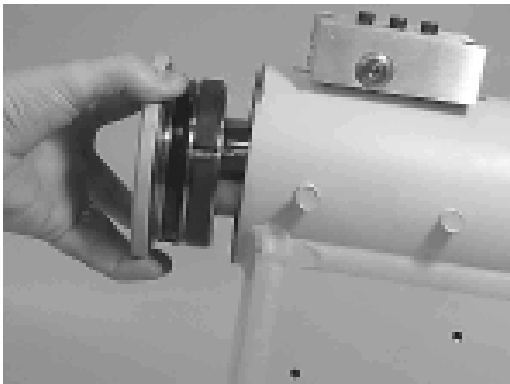

- 12.** Looking from the view shown, use the existing timing marks to line up the gear teeth on the shaft (2) with the gear teeth on the inside of the piston (3). Now tap the flange end of the shaft with a rubber mallet until the gear teeth engage.



- 13.** Install 2 bolts in the threaded holes in the flange. Using a bar, rotate the shaft in a clockwise direction until the wear guides are seated inside the housing bore.

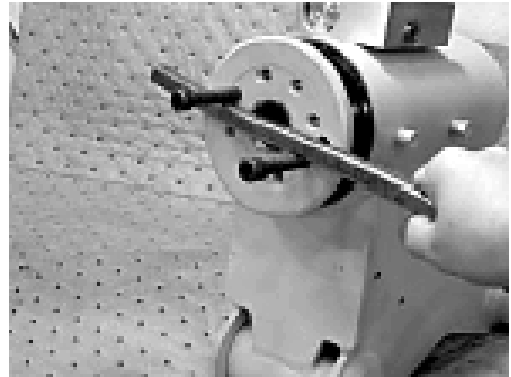

- 14.** Install the stop tube onto the shaft end. Stop tube is an available option to limit the rotation of an actuator.

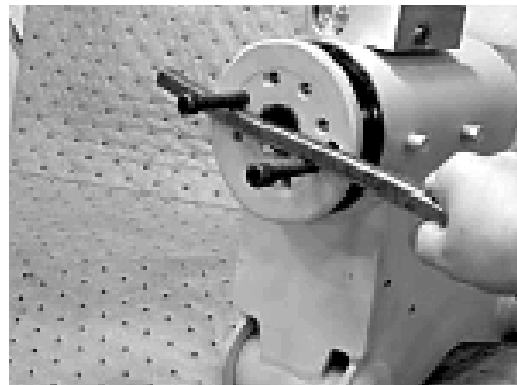

- 15.** Coat the threads on the end of the shaft with anti-seize grease to prevent galling.



SECTION 4 - BOOM & PLATFORM

16. Install the O-ring (204) and back-up ring (207) into the inner seal groove on the end cap (4).



17. Thread the end cap (4) onto the shaft (2) end. Make sure the wear guide stays in place on the end cap as it is threaded into the housing (1).



18. Tighten the end cap (4). In most cases the original holes for the lock pins will line up.



19. Place the lock pins (109) provided in the Helac seal kit in the holes with the dimple side up. Then, using a punch, tap the lock pins to the bottom of the hole.



20. Insert the set screws (113) over the lock pins. Tighten them to 25 in. lbs. (2.825 Nm).



Installing Counterbalance Valve

Refer to Figure 4-13., Rotator Counterbalance Valve.

1. Make sure the surface of the actuator is clean, free of any contamination and foreign debris including old Loctite.
2. Make sure the new valve has the O-rings in the counterbores of the valve to seal it to the actuator housing.
3. The bolts that come with the valve are grade 8 bolts. New bolts should be installed with a new valve. Loctite #242 should be applied to the shank of the three bolts at the time of installation.
4. Torque the 1/4-inch bolts 110 to 120 inch pounds (12.4 to 13.5 Nm). Do not torque over 125 inch pounds (14.1 Nm). Torque the 5/16-inch bolts 140 inch pounds (15.8 Nm). Do not torque over 145 inch pounds (16.3 Nm).

Testing the Actuator

If the equipment is available, the actuator should be tested on a hydraulic test bench. The breakaway pressure — the pressure at which the shaft begins to rotate — should be approximately 400 psi (28 bar). Cycle the actuator at least 25 times at 3000 psi (210 bar) pressure. After the 25 rotations, increase the pressure to 4500 psi (315 bar) to check for leaks and cracks. Perform the test again at the end of the rotation in the opposite direction.

TESTING THE ACTUATOR FOR INTERNAL LEAKAGE

If the actuator is equipped with a counterbalance valve, plug the valve ports. Connect the hydraulic lines to the housing ports. Bleed all air from the actuator (see Installation and Bleeding) Rotate the shaft to the end of rotation at 3000 psi (210 bar) and maintain pressure. Remove the hydraulic line from the non-pressurized side.

Continuous oil flow from the open housing port indicates internal leakage across the piston. Replace the line and rotate the shaft to the end of rotation in the opposite direction. Repeat the test procedure outlined above for the other port. If there is an internal leak, disassemble, inspect and repair.

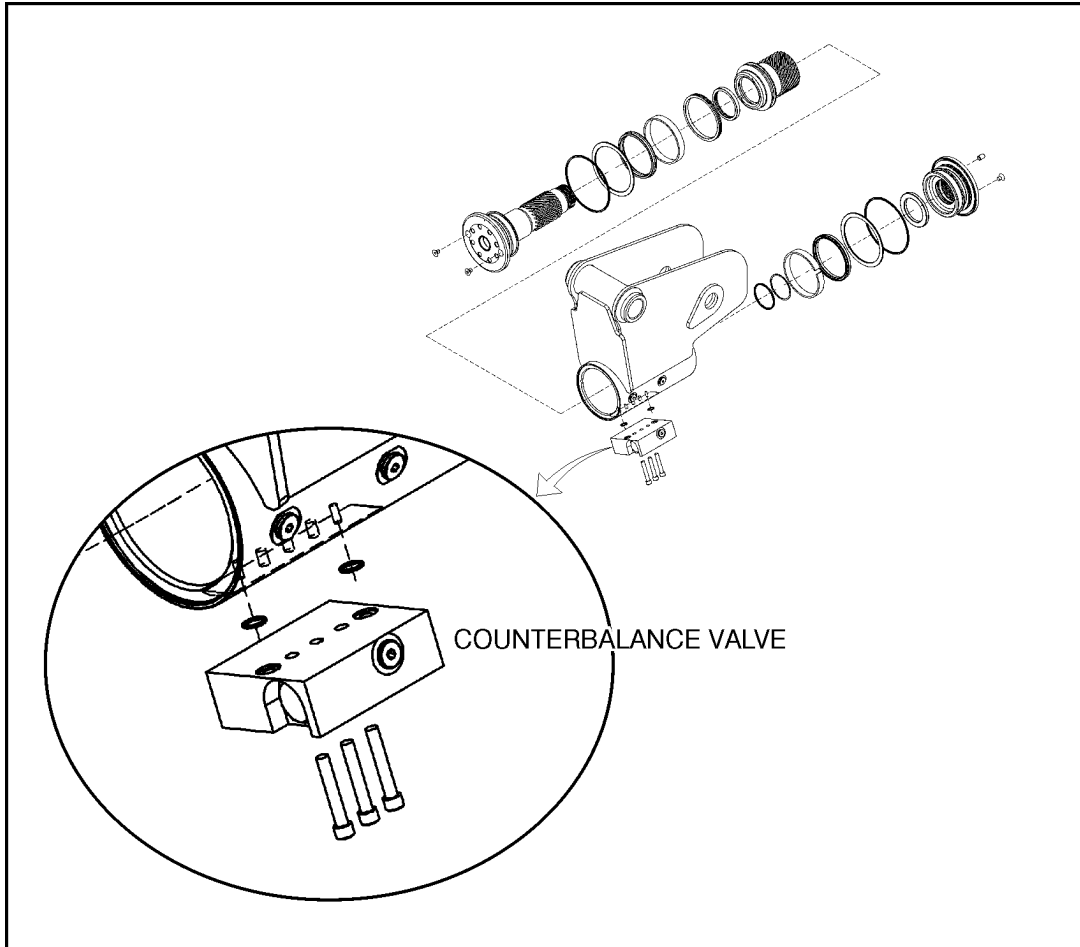

Figure 4-13. Rotator Counterbalance Valve

Installation and Bleeding

After installation of the actuator on the equipment, it is important that all safety devices such as tie rods or safety cables are properly reattached.

To purge air from the hydraulic lines, connect them together to create a closed loop and pump hydraulic fluid through them. Review the hydraulic schematic to determine which hydraulic lines to connect. The linear feet and inside diameter of the hydraulic supply lines together with pump capacity will determine the amount of pumping time required to fully purge the hydraulic system.

Bleeding may be necessary if excessive backlash is exhibited after the actuator is connected to the hydraulic system. The following steps are recommended when a minimum of two gallons (8 liters) is purged.

1. Connect a 3/16" inside diameter x 5/16" outside diameter x 5 foot clear, vinyl drain tube to each of the two bleed nipples. Secure them with hose clamps. Place the vinyl tubes in a clean 5-gallon container to collect the purged oil. The oil can be returned to the reservoir after this procedure is completed.

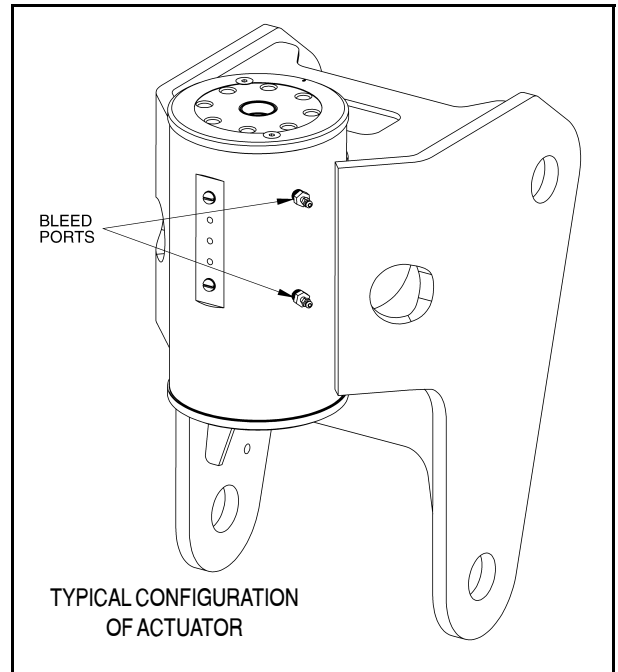

2. With an operator in the platform, open both bleed nipples 1/4 turn. Hydraulically rotate the platform to the end of rotation (either clockwise or counterclockwise), and maintain hydraulic pressure. Oil with small air bubbles will be seen flowing through the tubes. Allow a 1/2 gallon of fluid to be purged from the actuator.
3. Keep the fittings open and rotate the platform in the opposite direction to the end position. Maintain hydraulic pressure until an additional 1/4 gallon of fluid is pumped into the container.
4. Repeat steps 2 & 3. After the last 1/2 gallon is purged, close both bleed nipples before rotating away from the end position.

Troubleshooting

Table 4-1. Troubleshooting

Problem	Cause	Solution
1. Shaft rotates slowly or not at all	a. Insufficient torque output	a. Verify correct operating pressure. Do not exceed OEM's pressure specifications. Load may be above maximum capacity of the actuator.
	b. Low rate of fluid flow	b. Inspect ports for obstructions and hydraulic lines for restrictions and leaks.
	c. Control or counterbalance valve has internal leak	c. Disconnect hydraulic lines and bypass valve. Leave valve ports open and operate the actuator through housing ports (do not exceed OEM's operating pressure). The valve must be replaced if a steady flow of fluid is seen coming from the valve ports.
	d. Piston and/or shaft seal leak	d. Remove the plug and the housing's valve ports. Operate the actuator through the housing ports. Conduct the internal leakage test as described in the Testing section on page 24 of this manual.
	e. Corrosion build-up on the thrust surfaces	e. Re-build the actuator. Remove all rust then polish. Replacement parts may be needed.
	f. Swollen seals and composite bearings caused by incompatible hydraulic fluid	f. Re-build the actuator. Use fluid that is compatible with seals and bearings.
2. Operation is erratic or not responsive	a. Air in actuator	a. Purge air from actuator. See bleeding procedures.
3. Shaft will not fully rotate	a. Twisted or chipped gear teeth	a. Check for gear binding. Actuator may not be able to be re-built and may need to be replaced. Damage could be a result of overload or shock.
	b. Port fittings are obstructing the piston	b. Check thread length of port fittings. Fittings should during stroke not reach inside the housing bore.
4. Selected position cannot be maintained	a. Control or counterbalance valve has internal leak	a. Disconnect hydraulic lines and bypass valve. Leave valve ports open and operate the actuator through housing ports (do not exceed OEM's operating pressure). The valve must be replaced if a steady flow of fluid is seen coming from the valve ports.
	b. Piston and/or shaft seal leak	b. Remove the plug and the housing's valve ports. Operate the actuator through the housing ports. Conduct the internal leakage test as described in the Testing section on page 24 of this manual.
	c. Air in actuator	c. Purge air from actuator. See bleeding procedures

4.13 POWERTRACK MAINTENANCE

Removing a Link

NOTE: Hoses shown in the powertrack are for example only. Actual hose and cable arrangements will be different.



- 1. Clamp the bar and poly roller tightly so they do not spin when removing the screw. With a small 1/4" ratchet and a t-20 torx bit, remove the 8-32 x 0.500 screw from one side.



- 2. Repeat step 1 and remove the screw from the other side of track. Remove the bar/poly roller from the powertrack.



SECTION 4 - BOOM & PLATFORM

3. To remove a link, the rivets holding the links together must be removed. Use a right-angle pneumatic die grinder with a ¼" ball double cut bur attachment.

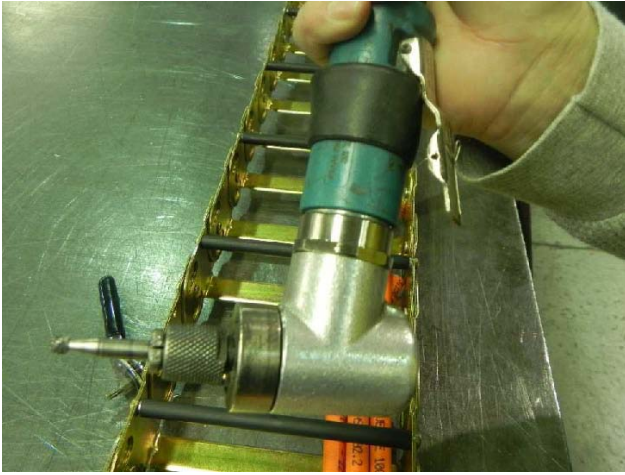

4. Insert the tool into the rolled over end of the rivet as shown. Grind out the middle of the rivet until the rolled over part of the rivet falls off. Repeat this step for all the rivets that must be removed.

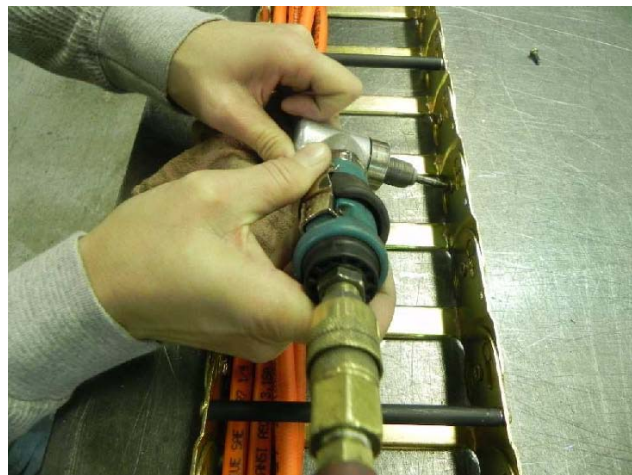
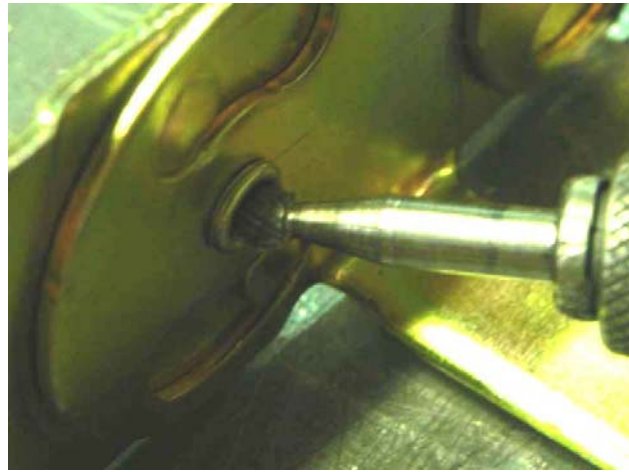

NOTICE

MOVE THE CABLES/HOSES OUT OF THE WAY DURING THE GRINDING PROCESS TO PROTECT THEM. KEEP THE HOSES AND CABLES COVERED TO PREVENT ANY DEBRIS FROM GETTING ON THEM.

- 5. After grinding it may be necessary to help the rivet out by using a center punch with a hammer.

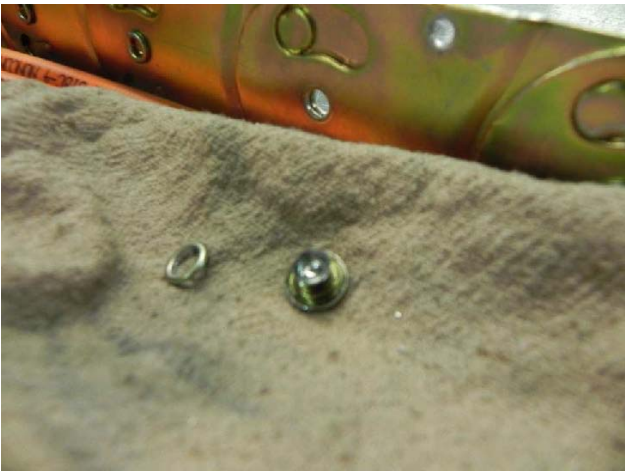

- 6. Using a flat head screwdriver between the links, twist the screwdriver and pull the links apart.



NOTE: It may be necessary to loosen the fixed end brackets from the machine in order to twist and pull the track section enough to disconnect the links.

SECTION 4 - BOOM & PLATFORM

7. Remove the link from the other section of the powertrack using a screwdriver.

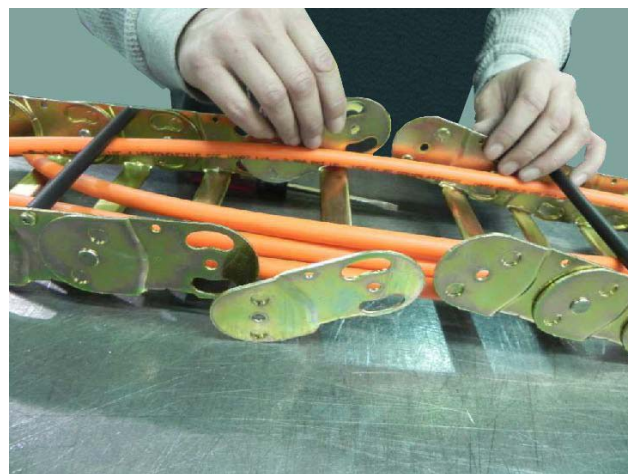
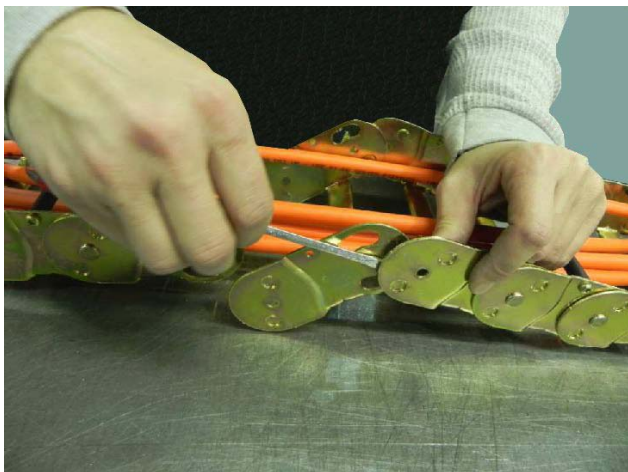

Installing a New Link

1. Squeeze the peanut cut out end of the new link into the half-shear (female) end of the track section.

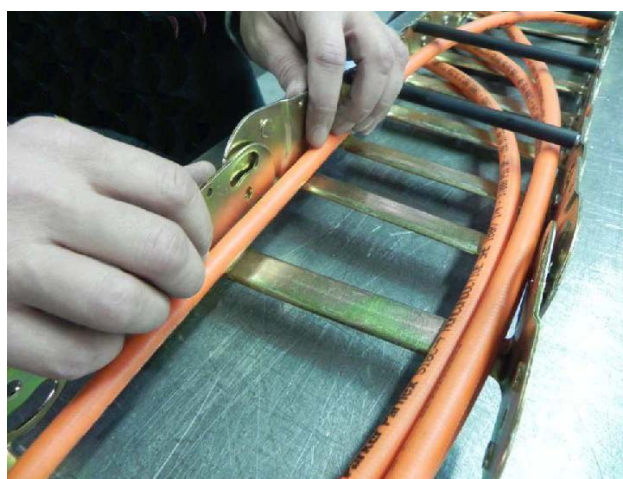

- 2. Spread apart the half-shear (female) end of the new link and slide the peanut end of the track section into it. a screwdriver may be necessary to do this.

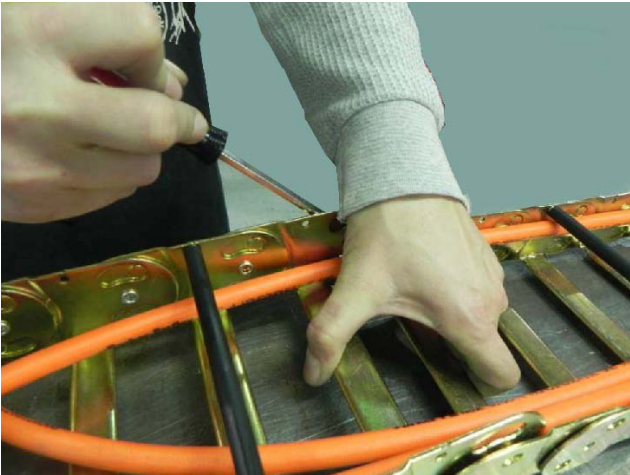
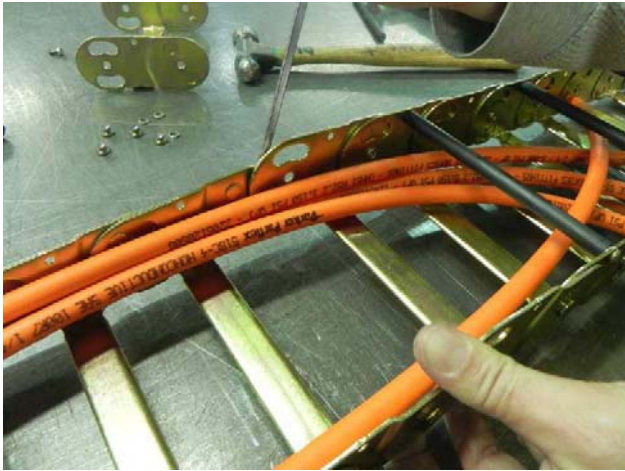

- 3. After the new link is installed in the powertrack the round half-shears will not fit properly in the peanut cut-outs yet.

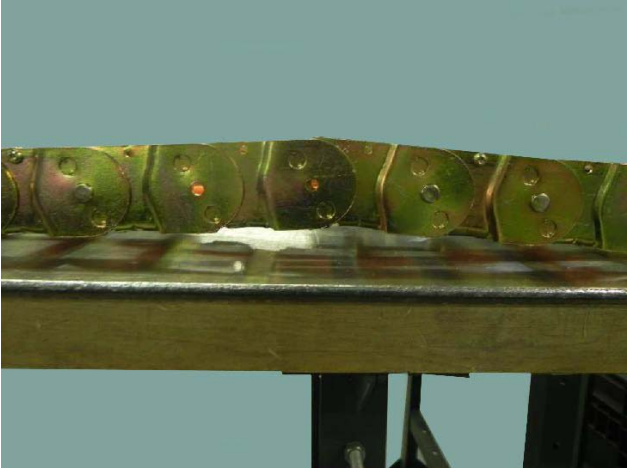

SECTION 4 - BOOM & PLATFORM

4. Pull the moving end out over the track so that the new connection is positioned in the curve of the powertrack. In this position the round half-shears will rotate into the peanut cut outs.



5. The parts shown below will be used to connect the new link to the powertrack.

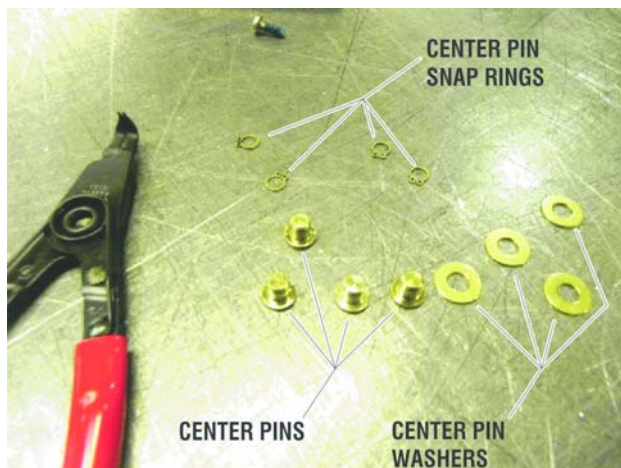

6. Push pin thru center hole then slide washer on pin.



- 7. Install the snap ring in the groove on the pin. Repeat the pin installation steps for all center holes that have the rivets removed.



NOTE: When installing snap rings make sure they are seated in pin groove and closed properly.



- 8. Hold new aluminum round bar tightly, then install new 8-32 x 0.500 self-threading torx head screw into one end.

SECTION 4 - BOOM & PLATFORM

NOTE: Maximum tightening torque is 18-20 in-lbs.

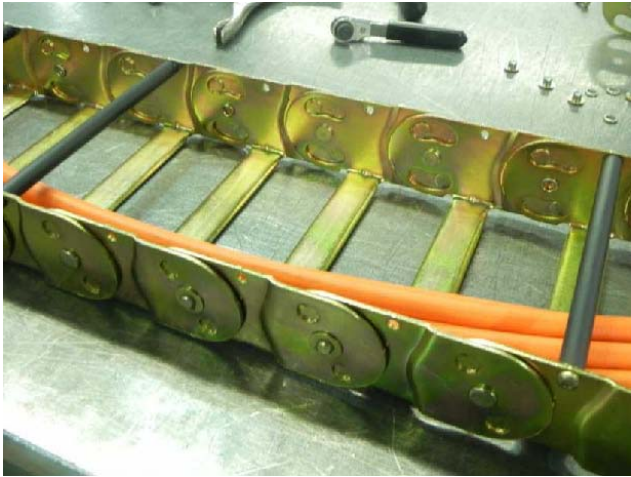

9. Pull up on the other end of the round bar and slide the new poly roller onto the bar.

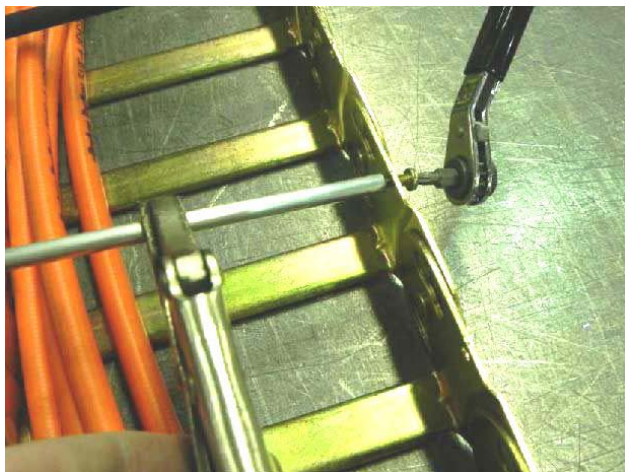
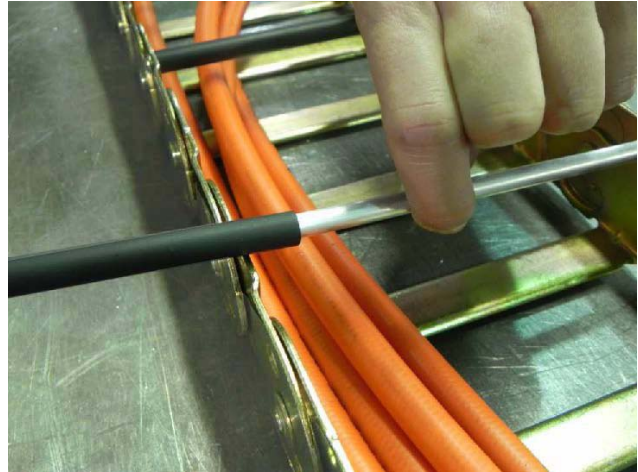

10. Install a new 8-32 x 0.500 self threading screw on the other side.

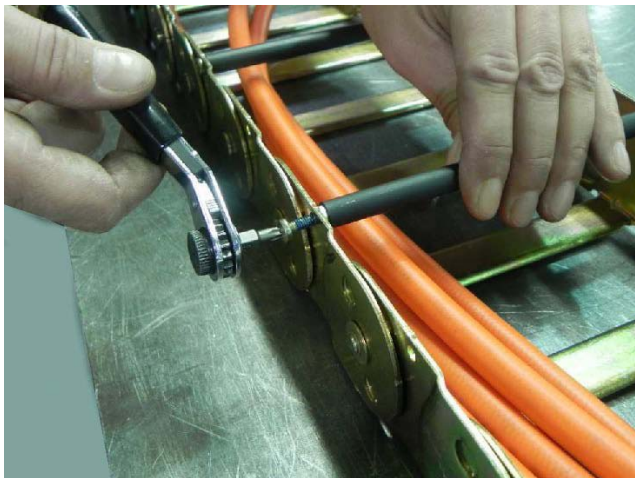

NOTE: When tightening screws make sure screw head is seated against link with no space in between the link and underside of screw head. Maximum tightening torque is 18-20 in-lbs.

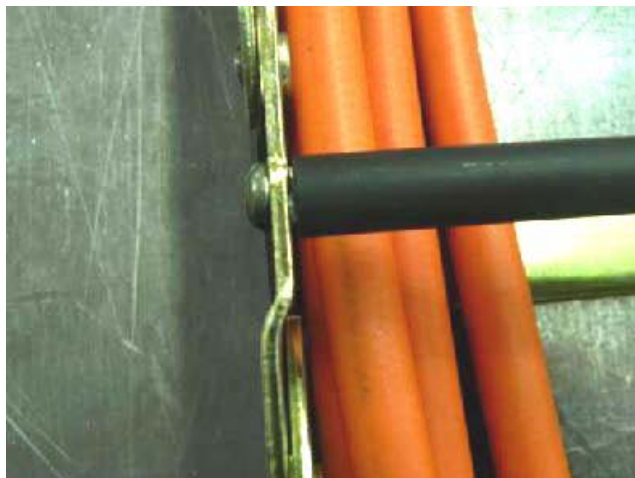

Replacing Fixed End Brackets

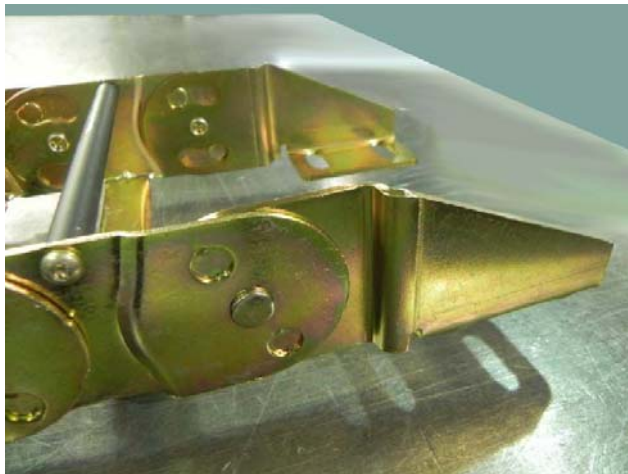

1. Remove the rivets the same way as shown under the link removal instructions.

NOTICE

MOVE THE CABLES/HOSES OUT OF THE WAY DURING THE GRINDING PROCESS TO PROTECT THEM. KEEP THE HOSES AND CABLES COVERED TO PREVENT ANY DEBRIS FROM GETTING ON THEM.

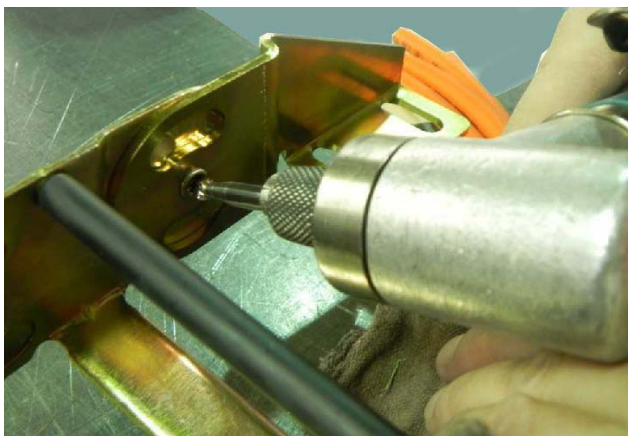

SECTION 4 - BOOM & PLATFORM

2. Parts used: Bracket Center Pin and Center Pin Snap Ring.



NOTE: When installing snap rings make sure they are seated in pin groove and closed properly.

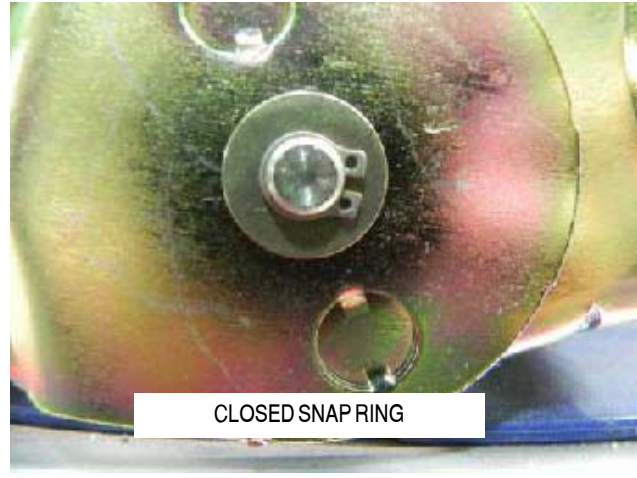

3. Take the new bracket and install bracket center pin and snap ring. Repeat on the other bracket if replacing it as well.



Replacing Moving End Brackets



- 1. Remove existing pins and center rivet. Remove the rivet the same way as shown in the link removal instructions. Repeat on other bracket if replacing it as well.

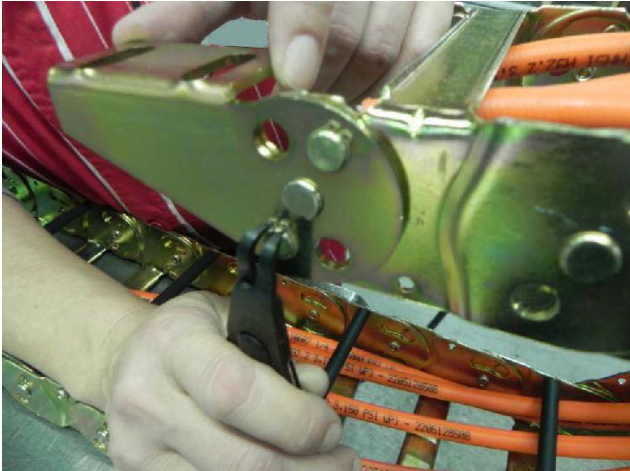

NOTICE

MOVE THE CABLES/HOSES OUT OF THE WAY DURING THE GRINDING PROCESS TO PROTECT THEM. KEEP THE HOSES AND

CABLES COVERED TO PREVENT ANY DEBRIS FROM GETTING ON THEM.

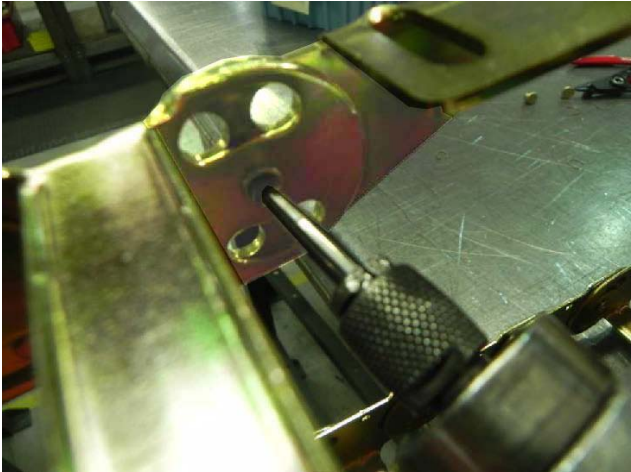

- 2. Take new bracket and install center pin with snap ring.

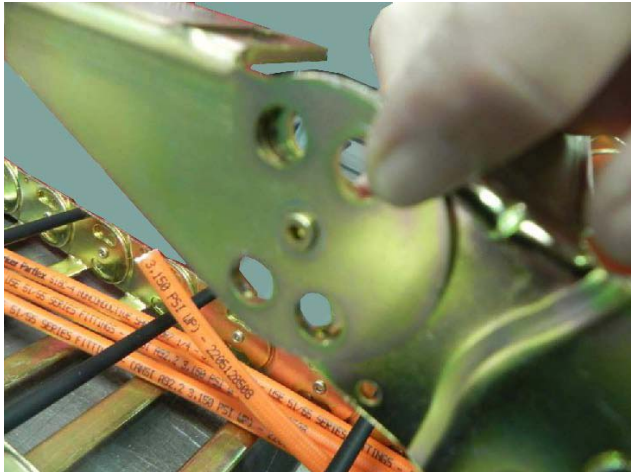
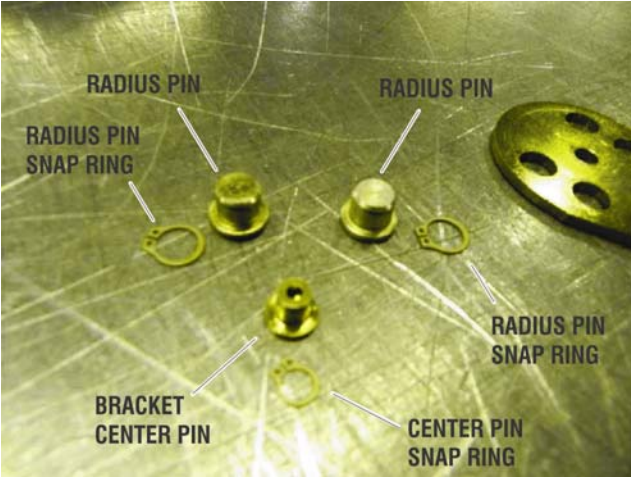

SECTION 4 - BOOM & PLATFORM

3. Install radius pins into their original locations and install snap rings. Repeat with other moving end if replacing as well.

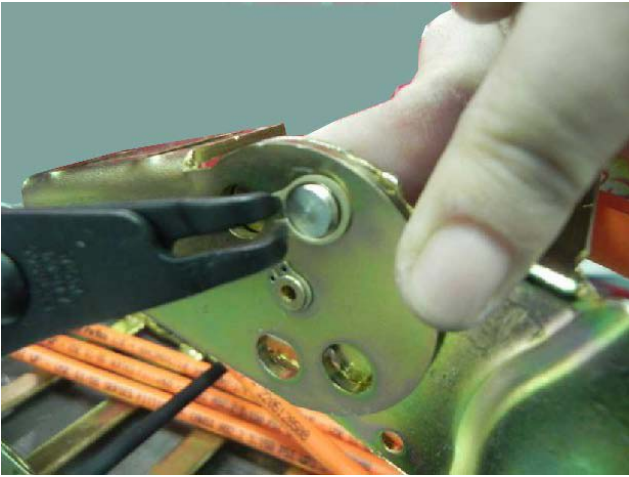

NOTE: When installing snap rings make sure they are seated in pin groove and closed properly.



4. When complete make sure that both brackets rotate correctly.



SECTION 5. HYDRAULICS

5.1 LUBRICATING O-RINGS IN THE HYDRAULIC SYSTEM

When assembling connectors in the hydraulic that use o-ring fittings, it is necessary to lubricate all fittings with hydraulic oil prior to assembly. To lubricate the fittings, use one of the following procedures.

NOTE: All O-ring fittings must be pre-lubricated with hydraulic oil prior to assembly.

Cup and Brush

The following is needed to correctly oil the o-ring in this manner:

- A small container for hydraulic oil
- Small paint brush



1. Hold the fitting in one hand while using the brush with the other hand to dip into the container. Remove excess hydraulic oil from the brush so an even film of oil is applied on the o-ring.



2. Holding the fitting over the hydraulic oil container, brush an even film of oil around the entire o-ring in the fitting, making sure the entire o-ring is completely saturated.



3. Turn the o-ring on the other side of the fitting and repeat the previous step, ensuring the entire o-ring is coated with hydraulic oil.



Dip Method

NOTE: This method works best with Face Seal o-rings, but will work for all o-ring fitting types.

The following is needed to correctly oil the o-ring in this manner:

- A small leak proof container
 - Sponge cut to fit inside the container
 - A small amount of hydraulic oil to saturate the sponge.
1. Place the sponge inside the container and add hydraulic oil to the sponge until it is fully saturated.
 2. Dip the fitting into the sponge using firm pressure. Upon lifting the fitting, a small droplet will form and drip from the bottom of the fitting. This should signify an even coating of oil on the fitting.



3. O-ring Boss type fittings will require more pressure in able to immerse more of the fitting into the saturated sponge. This will also cause more oil to be dispersed from the sponge.



Spray Method

This method requires a pump or trigger spray bottle.

1. Fill the spray bottle with hydraulic oil.
2. Hold the fitting over a suitable catch can.
3. Spray the entire o-ring surface with a medium coat of oil.



Brush-on Method

This method requires a sealed bottle brush.

1. Fill the bottle with hydraulic oil.
2. Using slight pressure to the body of the spray bottle, invert the bottle so the brush end is in the downward position.
3. Brush hydraulic oil on the entire o-ring, applying an even coat of oil.



5.2 CYLINDERS - THEORY OF OPERATION

Double Acting Cylinder

(Upper Boom Lift, Mid Boom Lift, Lower Boom Lift, Telescope, Slave, Master, Rotator, and Steer)

A double acting cylinder is one that requires oil flow to operate the cylinder rod in both directions. Directing oil (by actuating the corresponding control valve to the piston side of the cylinder) forces the piston to travel toward the rod end of the barrel, extending the cylinder rod (piston attached to rod). When the oil flow is stopped, movement of the rod will stop. By directing oil to the rod side of the cylinder, the piston will be forced in the opposite direction and the cylinder rod will retract.

Holding valves are used in the Lift circuits to prevent retraction of the cylinder rod should a hydraulic line rupture or leak develop between the cylinder and its related control valve.

5.3 CYLINDER CHECKING PROCEDURES

NOTE: *Cylinder checks must be performed any time a cylinder component is replaced or when improper system operation is suspected.*

Cylinder Without Counterbalance Valves

(Steer, and Master Cylinders)

1. Using all applicable safety precautions, activate hydraulic system and fully extend cylinder to be checked. Shut down hydraulic system.
2. Carefully disconnect hydraulic hose from retract port of cylinder. There will be initial weeping of hydraulic fluid which can be caught in a suitable container. After initial discharge, there should be no further leakage from the retract port.
3. Activate hydraulic system, and activate cylinder extend function.
4. If cylinder retract port leakage is less than 6-8 drops per minute, carefully reconnect hose to retract port and retract cylinder. If leakage continues at a rate of 6-8 drops per minute or more, cylinder repairs must be made.
5. With cylinder fully retracted, shut down motor and carefully disconnect hydraulic hose from cylinder extend port.
6. Activate hydraulic system and activate cylinder retract function. Check extend port for leakage.
7. If extend port leakage is less than 6-8 drops per minute, carefully reconnect hose to extend port, then activate cylinder through one complete cycle and

check for leaks. If leakage continues at a rate of 6-8 drops per minute or more, cylinder repairs must be made.

Cylinders With Single Counterbalance Valve

(Upper Lift Cylinder)

NOTICE

OPERATE ALL FUNCTIONS FROM GROUND CONTROL STATION ONLY.

1. Using all applicable safety precautions, activate hydraulic system.

⚠ WARNING

WHEN WORKING ON THE UPPER BOOM LIFT CYLINDER RAISE THE UPPER BOOM TO HORIZONTAL AND PLACE A BOOM PROP APPROXIMATELY 1 INCH (2.54 CM) BELOW THE MAIN BOOM. IF WORKING ON LOWER BOOM LIFT CYLINDER, RAISE LOWER BOOM HALFWAY, FULLY ELEVATE UPPER BOOM AND ATTACH OVERHEAD CRANE TO THE UPRIGHT FOR SUPPORT, LEAVING APPROXIMATELY 1 INCH (2.54 CM) OF SLACK IN CHAIN OR SLING FOR TEST PURPOSES.

2. After completing the above, shut down hydraulic system and allow machine to sit for 10-15 minutes. This is done to relieve pressure in the hydraulic lines. Carefully remove hydraulic hoses from appropriate cylinder port block.
3. There will be initial weeping of hydraulic fluid, which can be caught in a suitable container. After the initial discharge, there should not be any further leakage from the ports. If leakage continues at a rate of 6-8 drops per minute or more, the following cylinder repairs must be made. If the retract port is leaking, the piston is leaking, the piston seals are defective and must be replaced. If the extend port is leaking, the counterbalance is defective and must be replaced.
4. If no repairs are necessary or when repairs have been made, carefully reconnect hydraulic hoses to the appropriate ports.
5. Remove boom prop/overhead crane, activate hydraulic system and run cylinder through complete cycle to check for leaks and operation.

SECTION 5 - HYDRAULICS

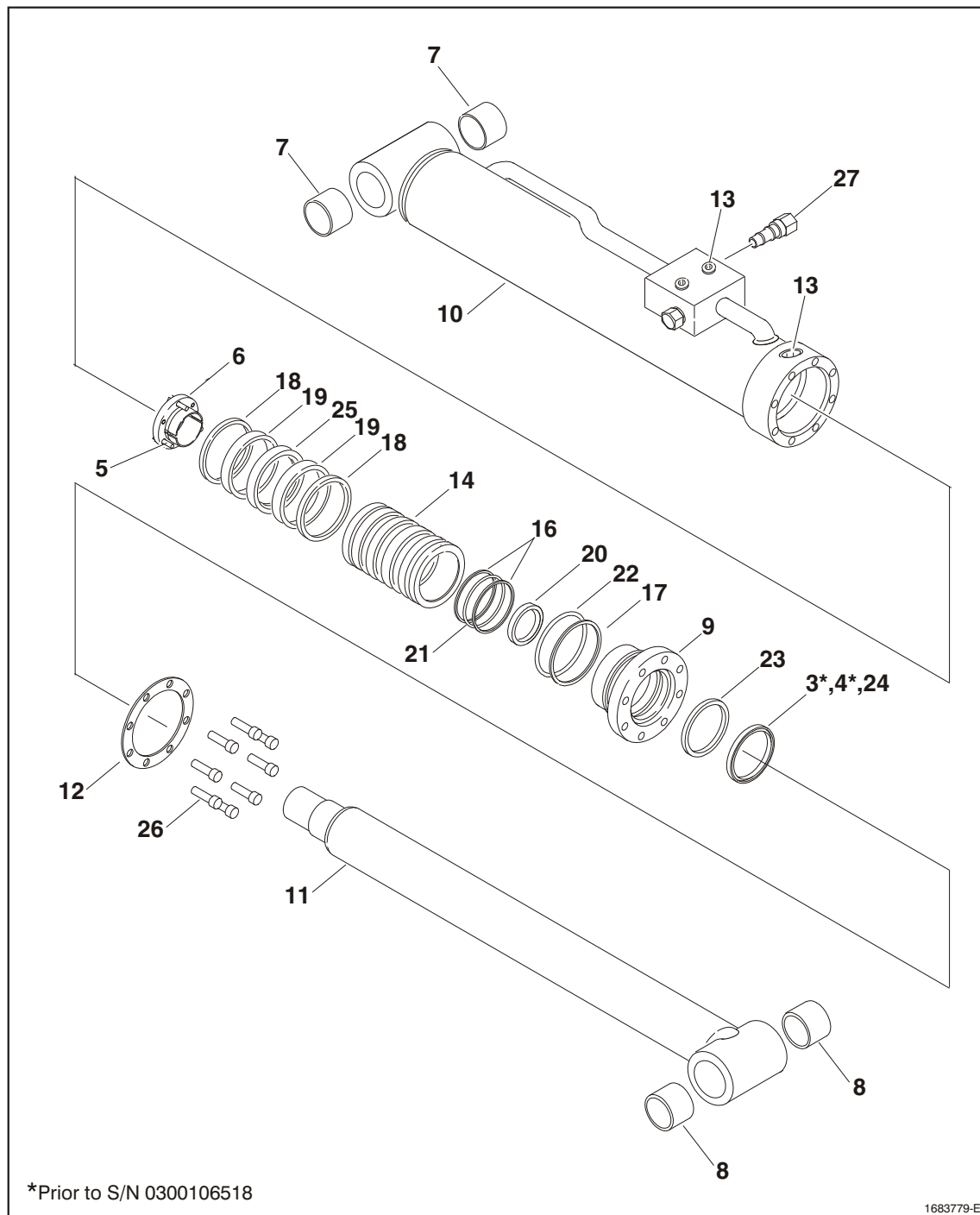

- | | | | | |
|--------------------|------------------|-----------------|---------------|---------------------|
| 1. Loctite #242 | 7. Bearing | 13. O-ring Plug | 19. Wear Ring | 25. Seal |
| 2. Loctite #222 | 8. Bushing | 14. Piston | 20. Wear Ring | 26. Bolt |
| 3. Primer #7471 | 9. Cylinder Head | 15. Not Used | 21. O-ring | 27. Valve Cartridge |
| 4. Loctite RC 609 | 10. Barrel | 16. Backup Ring | 22. O-ring | |
| 5. Bolt | 11. Cylinder Rod | 17. Backup Ring | 23. Seal | |
| 6. Tapered Bushing | 12. Washer Ring | 18. Seal Ring | 24. Wiper | |

Figure 5-1. Jib Cylinder

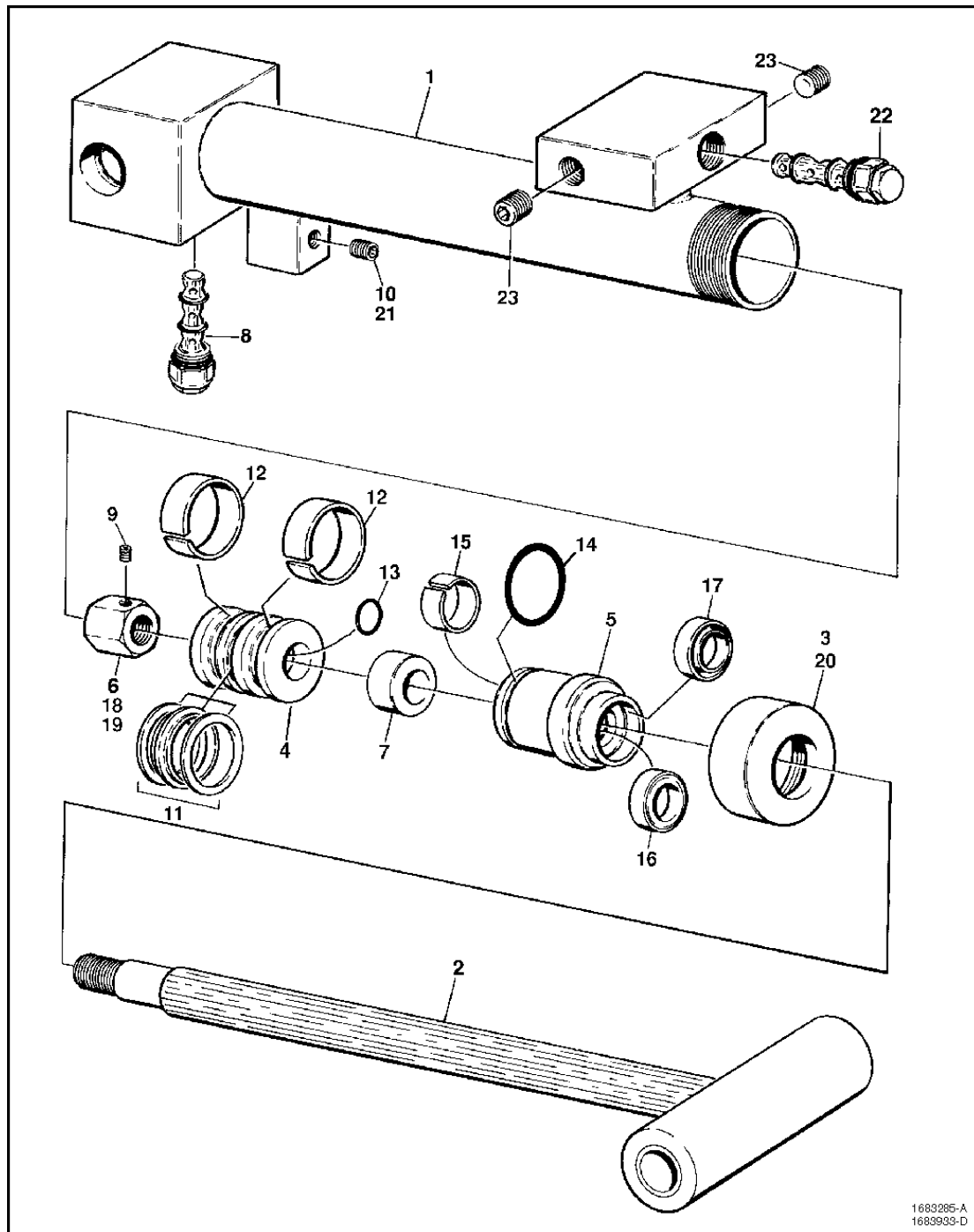

1689285-A
1689933-D

- | | | | |
|------------------|------------------|--------------------|-------------------|
| 1. Barrel | 7. Tube Spacer | 13. O-ring | 19. Loctite #242 |
| 2. Cylinder Rod | 8. Holding Valve | 14. O-ring | 20. Loctite #222 |
| 3. Retainer | 9. Setscrew | 15. Wear Ring | 21. Pipe Sealant |
| 4. Piston | 10. Pipe Plug | 16. Rod Seal | 22. Holding Valve |
| 5. Cylinder Head | 11. T-Seal | 17. Wiper | 23. Plug |
| 6. Hex Nut | 12. Wear Ring | 18. Locking Primer | |

Figure 5-2. Level Cylinder - A Models

SECTION 5 - HYDRAULICS

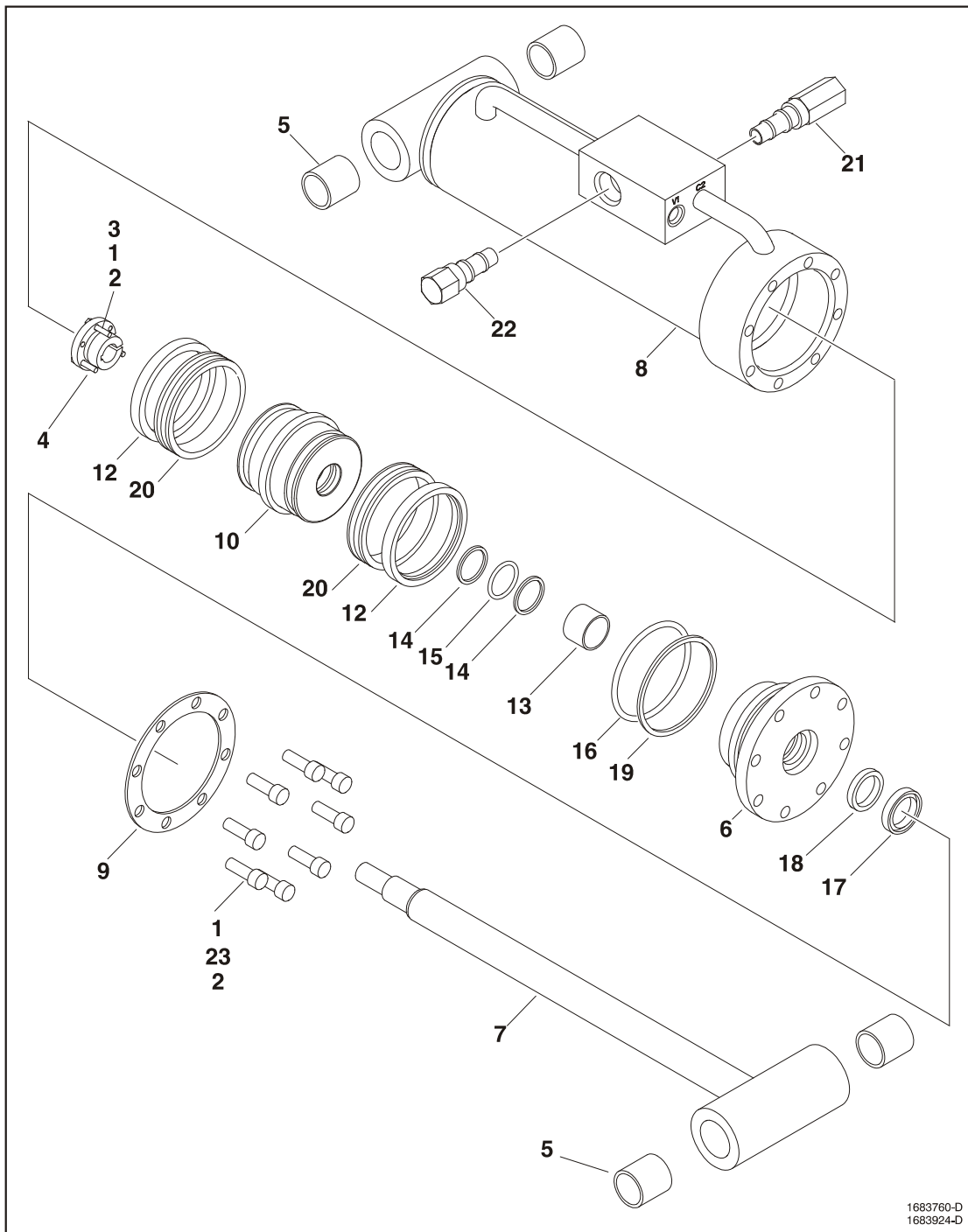

1683760-D
1683924-D

- | | | | |
|---------------------|-----------------|-----------------|---------------------|
| 1. Loctite #242 | 7. Cylinder Rod | 13. Wear Ring | 19. Backup Ring |
| 2. Primer #7471 | 8. Barrel | 14. Backup Ring | 20. Seal |
| 3. Socket Head Bolt | 9. Washer Ring | 15. O-ring | 21. Valve Cartridge |
| 4. Tapered Bushing | 10. Piston | 16. O-ring | 22. Valve Cartridge |
| 5. Bushing | 11. Not Used | 17. Wiper | 23. Bolt |
| 6. Cylinder Head | 12. Lock Ring | 18. Seal | |

Figure 5-3. Level Cylinder - AJ & AJP Models

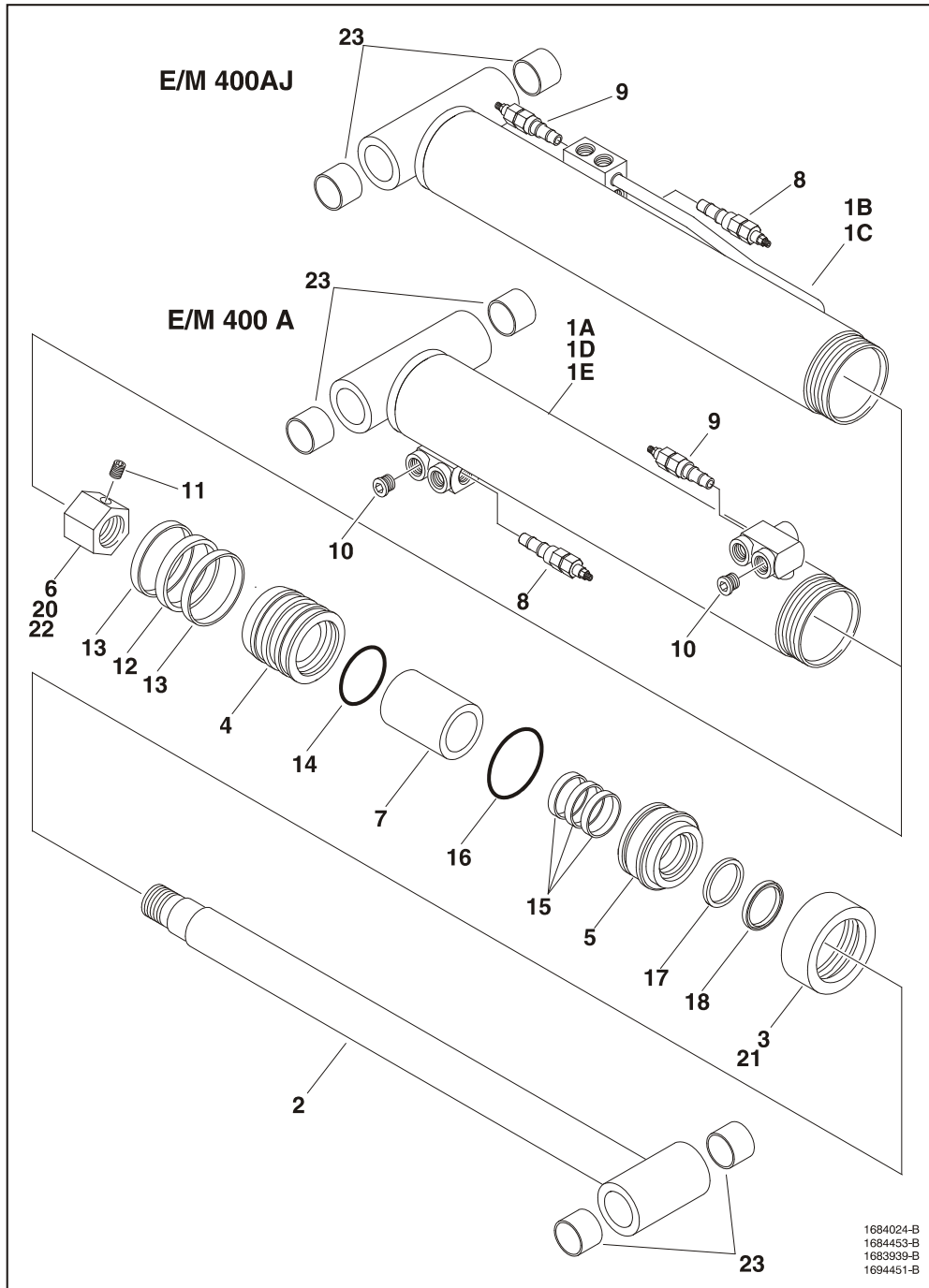

1684024-B
1684453-B
1683939-B
1694451-B

- | | | | |
|------------------|------------------|---------------|--------------------|
| 1. Barrel | 7. Tube Spacer | 13. Wear Ring | 19. Not Used |
| 2. Cylinder Rod | 8. Holding Valve | 14. O-ring | 20. Loctite #242 |
| 3. Retainer | 9. Holding Valve | 15. Wear Ring | 21. Loctite #222 |
| 4. Piston | 10. Pipe Plug | 16. O-ring | 22. Locking Primer |
| 5. Cylinder Head | 11. Setscrew | 17. Rod Seal | 23. Bushing |
| 6. Hex Nut | 12. Piston Seal | 18. Wiper | |

Figure 5-4. Lower Lift Cylinder

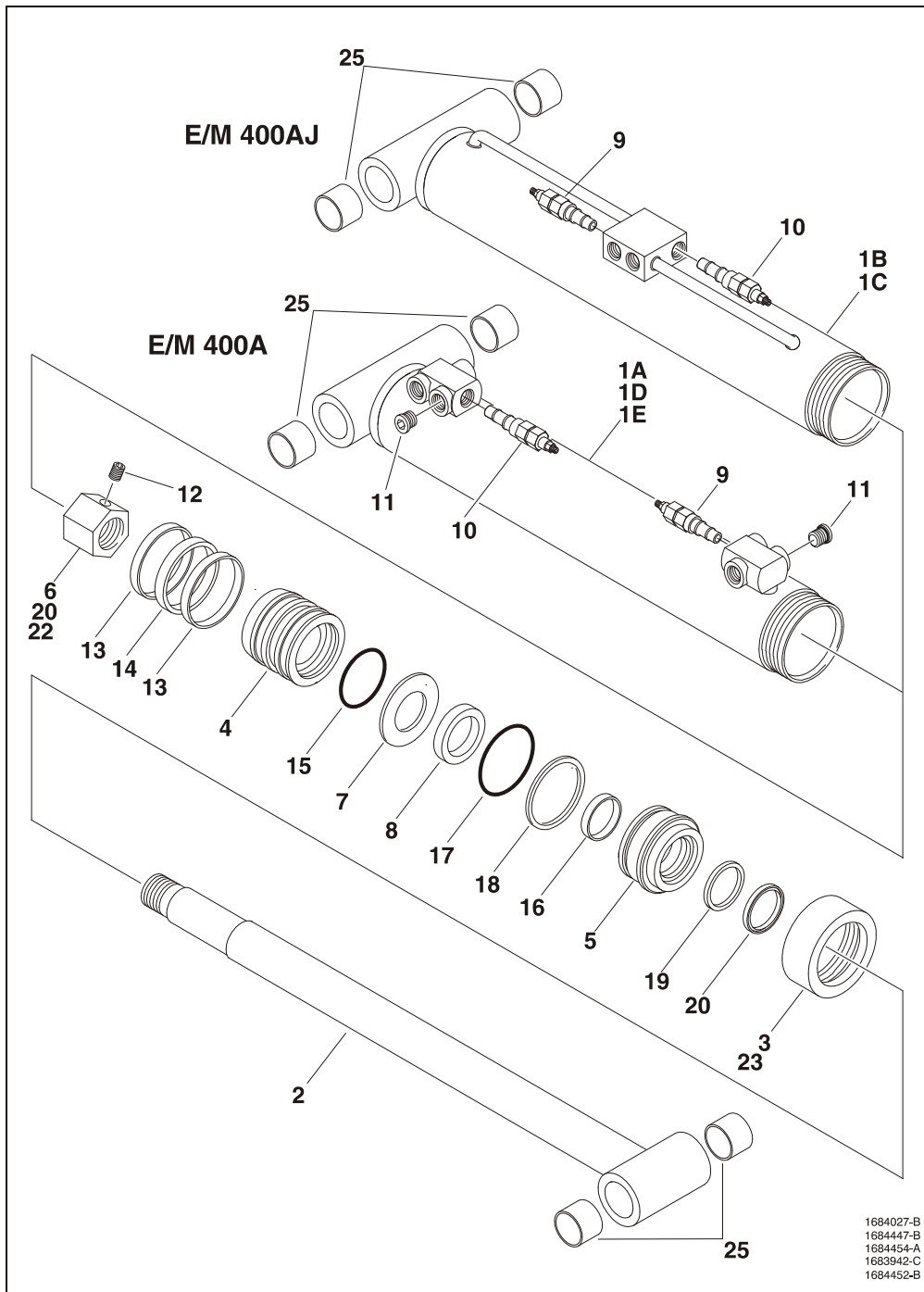

1684027-B
 1684447-B
 1684454-A
 1683942-C
 1684452-B

- | | | | | |
|------------------|-------------------|-----------------|-----------------|--------------------|
| 1. Barrel | 6. Hex Nut | 11. Plug | 16. Not Used | 21. Loctite #242 |
| 2. Cylinder Rod | 7. Washer | 12. Setscrew | 17. O-ring | 22. Loctite #222 |
| 3. Retainer | 8. Spacer | 13. Lock Ring | 18. Backup Ring | 23. Locking Primer |
| 4. Piston | 9. Holding Valve | 14. Piston Seal | 19. Rod Seal | 24. Not Used |
| 5. Cylinder Head | 10. Holding Valve | 15. Not Used | 20. Rod Wiper | 25. Bushing |

Figure 5-5. Mid Lift Cylinder

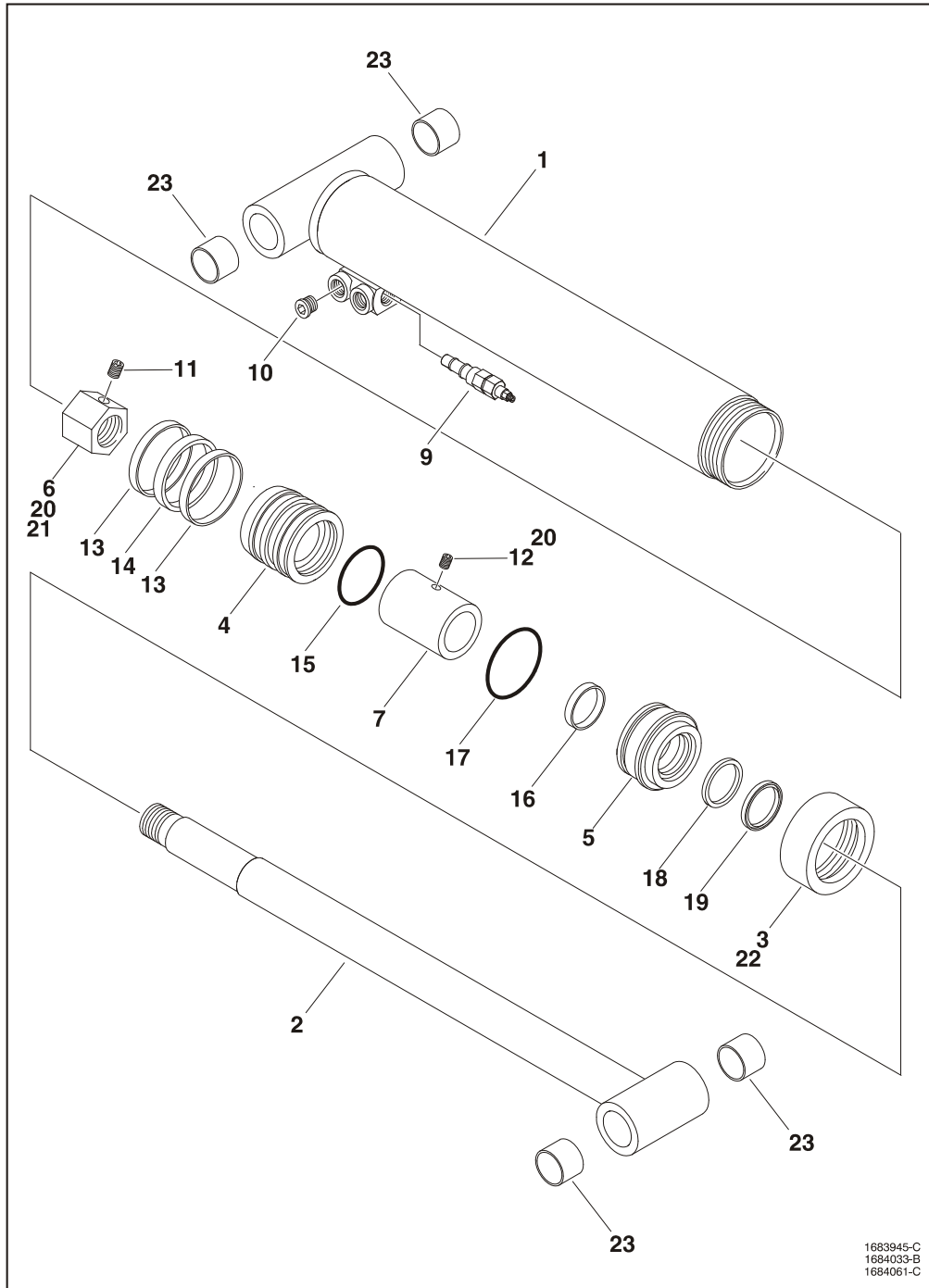

- | | | | | |
|------------------|------------------|---------------|------------------|--------------------|
| 1. Barrel | 6. Hex Nut | 11. Setscrew | 16. Wear Ring | 21. Locking Primer |
| 2. Cylinder Rod | 7. Tube Spacer | 12. Setscrew | 17. O-ring | 22. Loctite #222 |
| 3. End Cap | 8. Not Used | 13. Wear Ring | 18. Seal | 23. Bushing |
| 4. Piston | 9. Holding Valve | 14. Seal | 19. Wiper | |
| 5. Cylinder Head | 10. O-ring Plug | 15. O-ring | 20. Loctite #242 | |

Figure 5-6. Upper Lift Cylinder

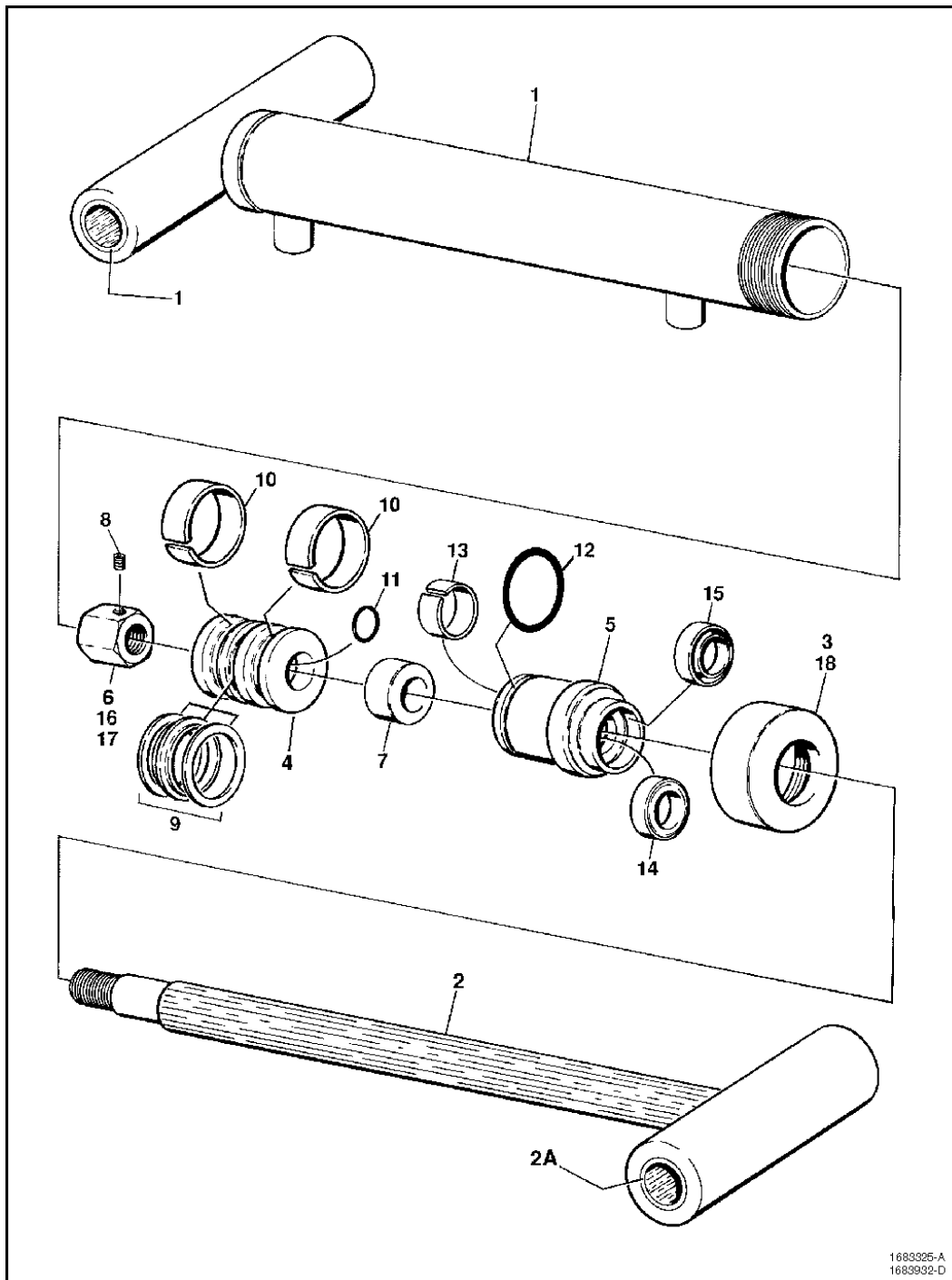

- | | | | |
|------------------|----------------|---------------|--------------------|
| 1. Barrel | 6. Hex Nut | 11. O-ring | 16. Locking Primer |
| 2. Cylinder Rod | 7. Tube Spacer | 12. O-ring | 17. Loctite #242 |
| 3. Retainer | 8. Setscrew | 13. Wear Ring | 18. Loctite #222 |
| 4. Piston | 9. T-Seal | 14. Rod Seal | |
| 5. Cylinder Head | 10. Wear Ring | 15. Rod Wiper | |

Figure 5-7. Master Cylinder - A Models

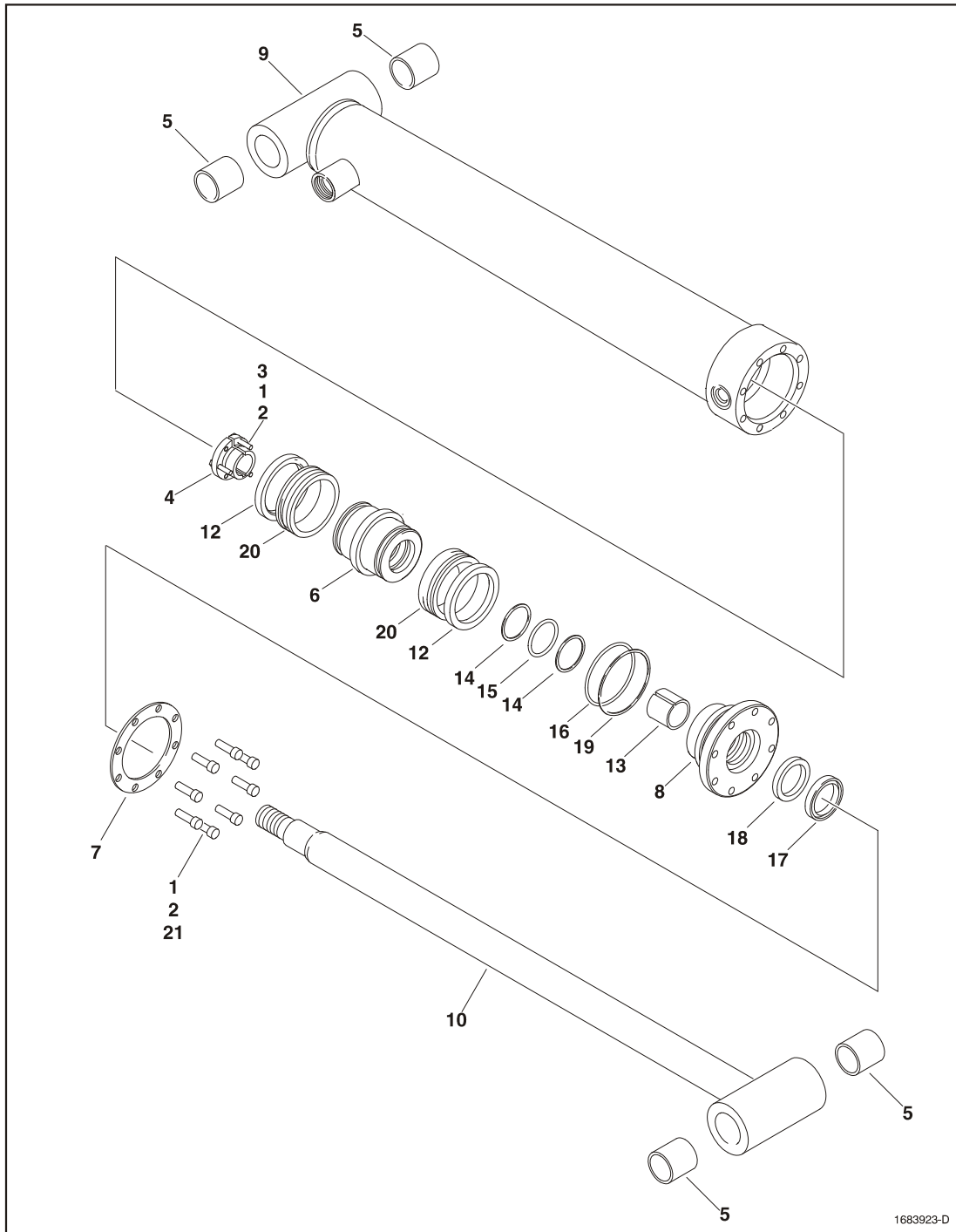

- | | | | | |
|--------------------|------------------|-----------------|-----------------|----------|
| 1. Loctite #242 | 6. Piston | 11. Not Used | 16. O-ring | 21. Bolt |
| 2. Locking Primer | 7. Washer | 12. Lock Ring | 17. Wiper | |
| 3. Bolt | 8. Head | 13. Wear Ring | 18. Seal | |
| 4. Tapered Bushing | 9. Barrel | 14. Backup Ring | 19. Backup Ring | |
| 5. Bushing | 10. Cylinder Rod | 15. O-ring | 20. Seal | |

Figure 5-8. Master Cylinder - AJ Models

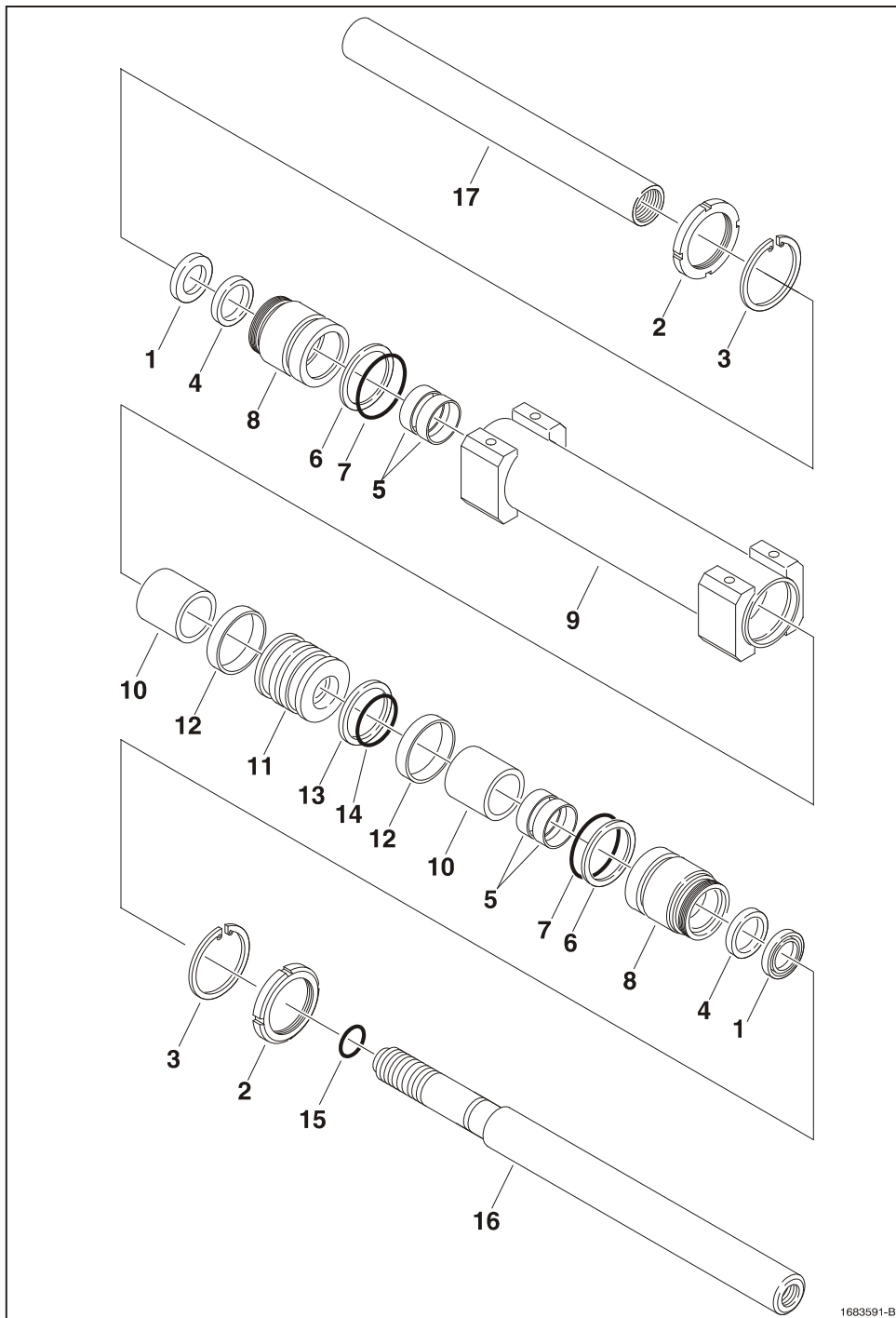

1683591-B

- | | | | |
|-------------------|----------------|---------------|---------|
| 1. Wiper | 6. Backup Ring | 11. Piston | 16. Rod |
| 2. Spanner Nut | 7. O-ring | 12. Wear Ring | 17. Rod |
| 3. Retaining Ring | 8. Guide | 13. Seal | |
| 4. Lip Seal | 9. Barrel | 14. O-ring | |
| 5. Wear Ring | 10. Tube | 15. O-ring | |

Figure 5-9. Steer Cylinder

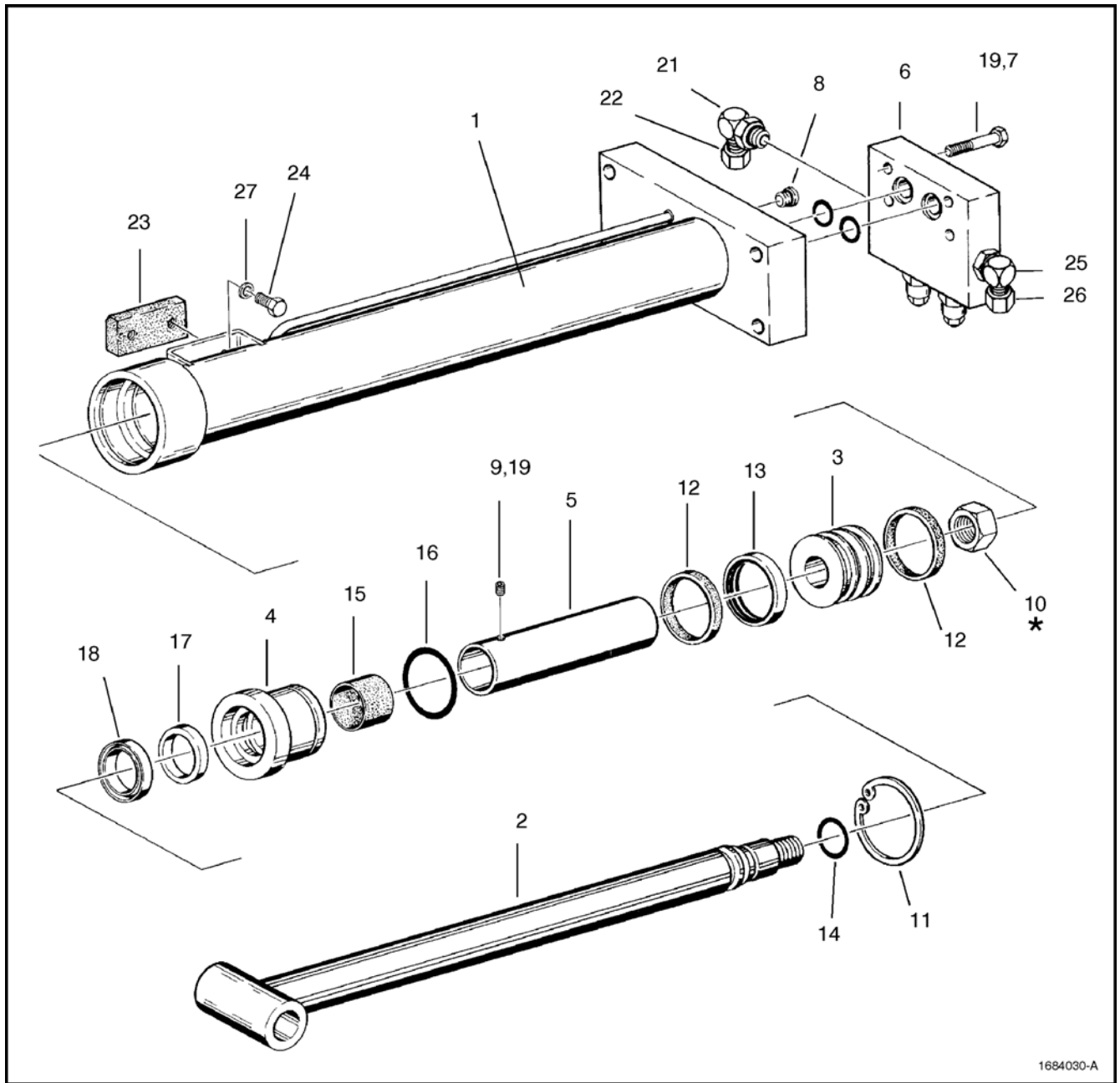

1684030-A

- | | | | | |
|-------------------------|--------------------|---------------|------------------|----------------|
| 1. Barrel | 7. Bolt | 13. Cap Seal | 19. Loctite #242 | 25. Fitting |
| 2. Rod | 8. Plug | 14. O-Ring | 20. Not Used | 26. Cap |
| 3. Piston | 9. Setscrew | 15. Wear Ring | 21. Fitting | 27. Lockwasher |
| 4. Head | 10. Locknut | 16. O-ring | 22. Cap | |
| 5. Spacer | 11. Retaining Ring | 17. Rod Seal | 23. O-Ring Plug | |
| 6. Counterbalance Valve | 12. Wear Ring | 18. Wiper | 24. Bolt | |

* Torque to 150 foot-pounds (203 Nm)

Figure 5-10. Telescope Cylinder

Cylinders With Dual Counterbalance Valve

(Lower Lift, Mid Lift, Telescope, and Slave Cylinders)

NOTICE

OPERATE ALL FUNCTIONS FROM GROUND CONTROL STATION ONLY.

1. Using all applicable safety precautions, activate hydraulic system.

WARNING

WHEN WORKING ON THE UPPER BOOM LIFT CYLINDER RAISE THE UPPER BOOM TO HORIZONTAL AND PLACE A BOOM PROP APPROXIMATELY 1 INCH (2.54 CM) BELOW THE MAIN BOOM. IF WORKING ON LOWER BOOM LIFT CYLINDER, RAISE LOWER BOOM HALFWAY, FULLY ELEVATE UPPER BOOM AND ATTACH OVERHEAD CRANE TO THE UPRIGHT FOR SUPPORT, LEAVING APPROXIMATELY 1 INCH (2.54 CM) OF SLACK IN CHAIN OR SLING FOR TEST PURPOSES.

2. When working on the platform slave cylinder, stroke platform slave level cylinder forward until platform sits at a 45 degree angle.
3. After completing the above, shut down hydraulic system and allow machine to sit for 10-15 minutes. This is done to relieve pressure in the hydraulic lines. Carefully remove hydraulic hoses from appropriate cylinder port block.
4. There will be initial weeping of hydraulic fluid, which can be caught in a suitable container. After the initial discharge, there should not be any further leakage from the ports. If leakage continues at a rate of 6-8 drops per minute or more, the following cylinder repairs must be made. If the retract port is leaking, the piston is leaking, the piston seals are defective and must be replaced. If the extend port is leaking, the counterbalance is defective and must be replaced.
5. To check piston seals, carefully remove the counterbalance valve from the retract port. After initial discharge there should not be any further leakage from the ports. If leakage occurs at a rate of 6-8 drops per minute or more, the piston seals are defective and must be replaced.
6. If no repairs are necessary or when repairs have been made, carefully reconnect hydraulic hoses to the appropriate ports.
7. Remove boom prop/overhead crane, activate hydraulic system and run cylinder through complete cycle to check for leaks and operation.

5.4 CYLINDER REPAIR

NOTE: The following are general procedures that apply to all of the cylinders on this machine. Procedures that apply to a specific cylinder will be so noted.

Disassembly

NOTICE

DISASSEMBLY OF THE CYLINDER SHOULD BE PERFORMED ON A CLEAN WORK SURFACE IN A DIRT FREE WORK AREA.

1. Connect a suitable auxiliary hydraulic power source to the cylinder port block fitting.

WARNING

DO NOT FULLY EXTEND CYLINDER TO THE END OF STROKE. RETRACT CYLINDER SLIGHTLY TO AVOID TRAPPING PRESSURE.

2. Operate the hydraulic power source and extend the cylinder. Shut down and disconnect the power source. Adequately support the cylinder rod, if applicable.
3. If applicable, remove the cartridge-type holding valve and fittings from the cylinder port block. Discard o-rings.
4. Place the cylinder barrel into a suitable holding fixture.

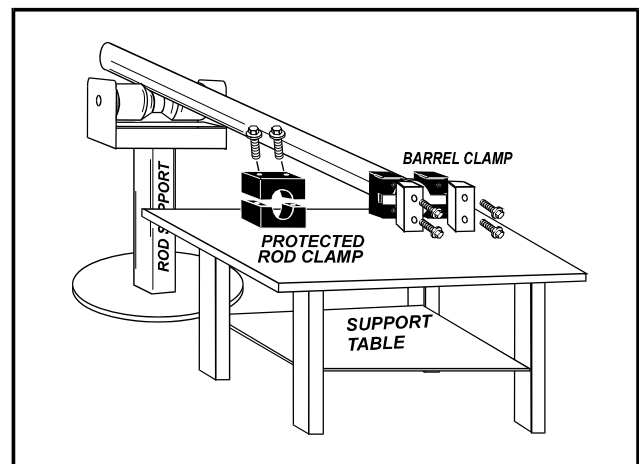

Figure 5-11. Cylinder Barrel Support

5. Mark cylinder head and barrel with a center punch for easy realignment. Using an allen wrench, loosen the cylinder head retainer cap screws, and remove cap screws from cylinder barrel.

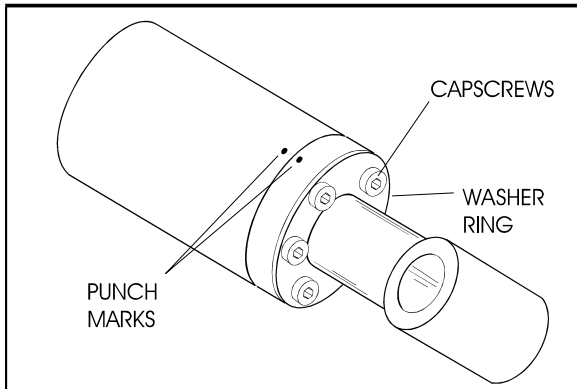

Figure 5-12. Capscrew Removal

NOTE: Steps 6 applies only to the lower lift and telescope cylinders.

6. Using a spanner wrench, loosen the end cap or head retainer, and remove from cylinder barrel.
7. Attach a suitable pulling device to the cylinder rod port block end or cylinder rod end, as applicable.

NOTICE

EXTREME CARE SHOULD BE TAKEN WHEN REMOVING THE CYLINDER ROD, HEAD, AND PISTON. AVOID PULLING THE ROD OFF-CENTER, WHICH COULD CAUSE DAMAGE TO THE PISTON AND CYLINDER BARREL SURFACES.

8. With the barrel clamped securely, apply pressure to the rod pulling device and carefully withdraw the complete rod assembly from the cylinder barrel.

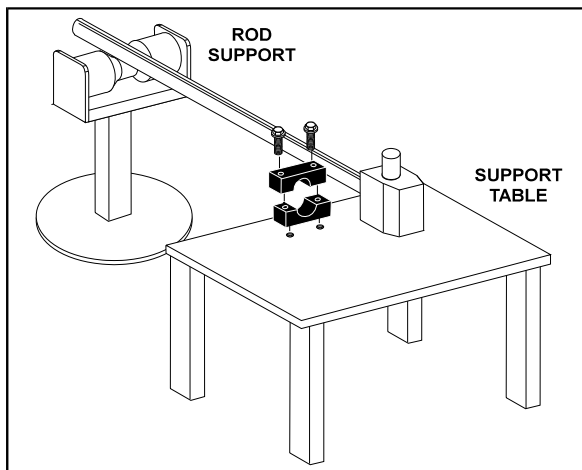

Figure 5-13. Cylinder Rod Support

9. Using suitable protection, clamp the cylinder rod in a vise or similar holding fixture as close to the piston as possible.
10. Loosen and remove the cap screw(s), if applicable, which attach the tapered bushing to the piston.
11. Insert the cap screw(s) in the threaded holes in the outer piece of the tapered bushing. Progressively tighten the cap screw(s) until the bushing is loose on the piston.
12. Remove the bushing from the piston.

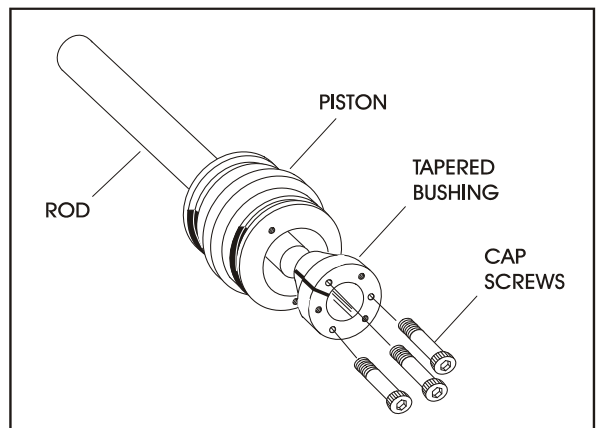

Figure 5-14. Tapered Bushing

13. Screw the piston CCW, by hand, and remove the piston from cylinder rod.
14. Remove and discard the piston o-rings, seal rings, and backup rings.
15. Remove piston spacer, if applicable, from the rod.
16. Remove the rod from the holding fixture. Remove the cylinder head gland and retainer plate, if applicable. Discard the o-rings, back-up rings, rod seals, and wiper seals.

Cleaning and Inspection

1. Clean all parts thoroughly in an approved cleaning solvent.
2. Inspect the cylinder rod for scoring, tapering, ovality, or other damage. If necessary, dress rod with Scotch Brite or equivalent. Replace rod if necessary.
3. Inspect threaded portion of rod for excessive damage. Dress threads as necessary.
4. Inspect inner surface of cylinder barrel tube for scoring or other damage. Check inside diameter for tapering or ovality. Replace if necessary.
5. Inspect threaded portion of barrel for damage. Dress threads as necessary.

SECTION 5 - HYDRAULICS

6. Inspect piston surface for damage and scoring and for distortion. Dress piston surface or replace piston as necessary.
7. Inspect threaded portion of piston for damage. Dress threads as necessary.
8. Inspect seal and o-ring grooves in piston for burrs and sharp edges. Dress applicable surfaces as necessary.
9. Inspect cylinder head inside diameter for scoring or other damage and for ovality and tapering. Replace as necessary.
10. Inspect threaded portion of head for damage. Dress threads as necessary.
11. Inspect seal and o-ring grooves in head for burrs and sharp edges. Dress applicable surfaces as necessary.
12. Inspect cylinder head outside diameter for scoring or other damage and ovality and tapering. Replace as necessary.
13. If applicable, inspect rod and barrel bearings for signs of correct excessive wear or damage. Replace as necessary.
 - a. Thoroughly clean hole, (steel bushing) of burrs, dirt etc. to facilitate bearing installation.
 - b. Inspect steel bushing for wear or other damage. If steel bushing is worn or damaged, rod/barrel must be replaced.
 - c. Lubricate inside of the steel bushing with WD40 prior to bearing installation.
 - d. Using an arbor of the correct size, carefully press the bearing into steel bushing.

NOTE: Install pin into the Gar-Max bearing dry. Lubrication is not required with nickel plated pins and bearings.

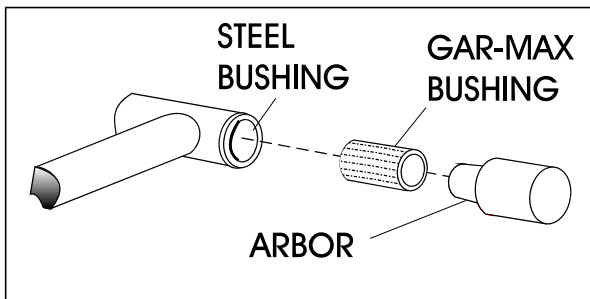

Figure 5-15. Gar-Max Bearing

14. Inspect travel limiting collar or spacer for burrs and sharp edges. If necessary, dress inside diameter surface with Scotch Brite or equivalent.
15. If applicable, inspect port block fittings and holding valve. Replace as necessary.

16. Inspect the oil ports for blockage or the presence of dirt or other foreign material. Repair as necessary.
17. If applicable, inspect piston rings for cracks or other damage. Replace as necessary.

Assembly

NOTE: Prior to cylinder assembly, ensure that the proper cylinder seal kit is used. See your JLG Parts Manual.

Apply a light film of hydraulic oil to all components prior to assembly.

1. A special tool is used to install a new rod seal into the applicable cylinder head gland groove.

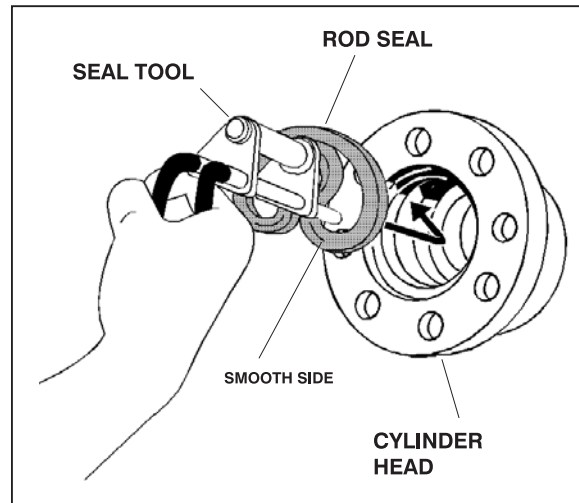

Figure 5-16. Rod Seal Installation

NOTICE

WHEN INSTALLING "POLY-PAK" PISTON SEALS, ENSURE SEALS ARE INSTALLED PROPERLY. REFER TO WIPER SEAL INSTALLATION FOR CORRECT SEAL ORIENTATION. IMPROPER SEAL INSTALLATION COULD RESULT IN CYLINDER LEAKAGE AND IMPROPER CYLINDER OPERATION.

2. Use a soft mallet to tap a new wiper seal into the applicable cylinder head gland groove. Install a new wear ring into the applicable cylinder head gland groove.

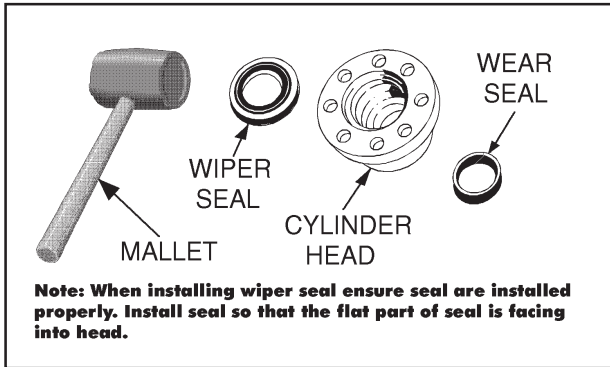

Figure 5-17. Wiper Seal Installation

3. Place a new o-ring and back-up seal in the applicable outside diameter groove of the cylinder head.

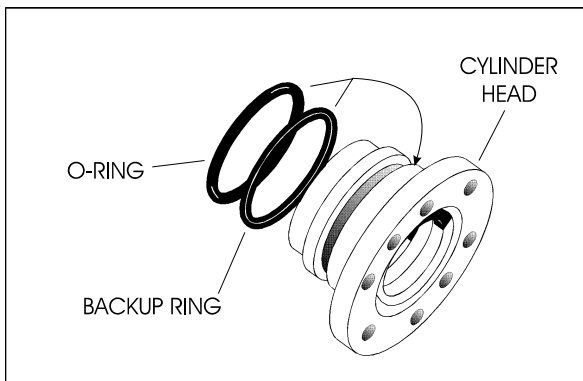

Figure 5-18. Installation of Head Seal Kit

4. Install washer ring onto rod, carefully install the head gland on the rod, ensuring that the wiper and rod seals are not damaged or dislodged. Push the head along the rod to the rod end, as applicable.
5. Carefully slide the piston spacer on the rod.
6. If applicable, correctly place new o-ring in the inner piston diameter groove. (The backup ring side facing the O-ring is grooved.)
7. If applicable, correctly place new seals and guide lock rings in the outer piston diameter groove. (A tube, with I.D. slightly larger than the O.D. of the piston is recommended to install the solid seal.)

NOTE: The backup rings for the solid seal have a radius on one side. This side faces the solid seal. (See magnified insert in Figure 5-19.) The split of seals and backup rings are to be positioned so as not to be in alignment with each other.

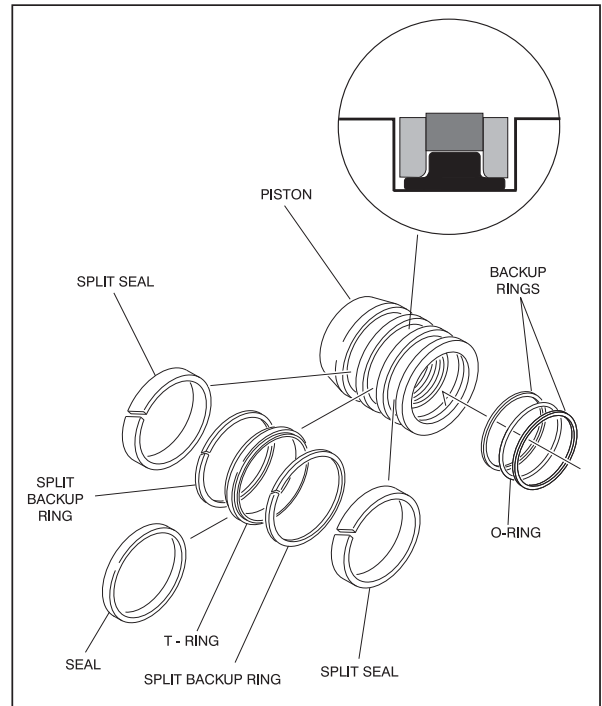

Figure 5-19. Piston Seal Kit Installation

8. Using suitable protection, clamp the cylinder rod in a vise or similar holding fixture as close to piston as possible.
9. Carefully thread the piston on the cylinder rod hand tight, ensuring that the o-ring and back-up rings are not damaged or dislodged.
10. Thread piston onto rod until it abuts the spacer end and install the tapered bushing.

SECTION 5 - HYDRAULICS

NOTE: When installing the tapered bushing, piston and mating end of rod must be free of oil.

⚠ WARNING

WHEN REBUILDING THE STEER, LOWER LIFT, LEVEL CYLINDER, OR UPPER LIFT CYLINDER, APPLY LOCTITE #242 TO TAPERED BUSHING BOLTS, THEN TIGHTEN SECURELY.

11. Assemble the tapered bushing loosely into the piston and insert JLG cap screws (not vendor cap screws) through the drilled holes in the bushing and into the tapped holes in the piston.

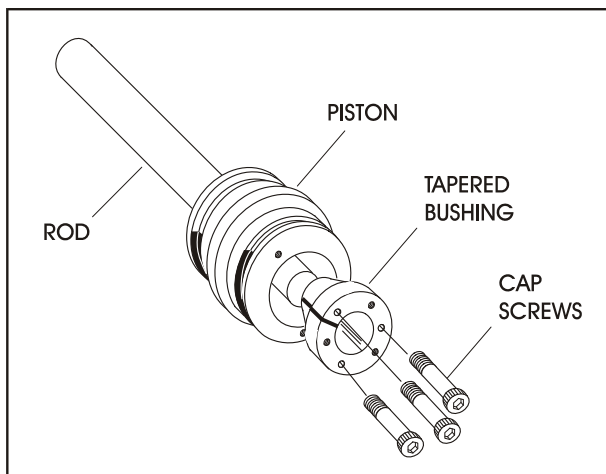

Figure 5-20. Tapered Bushing Installation

12. Tighten the cap screws evenly and progressively in rotation to the specified torque value. (See Table 5-1, Cylinder Head and Tapered Bushing Torque Specifications.)
13. After the screws have been torqued, tap the tapered bushing with a hammer (16 to 24 oz.) and brass shaft (approximately 3/4" in diameter) as follows;
 - a. Place the shaft against the cylinder rod and in contact with the bushing in the spaces between the cap screws.
 - b. Tap each space once; this means the tapered bushing is tapped 3 times as there are 3 spaces between the cap screws.

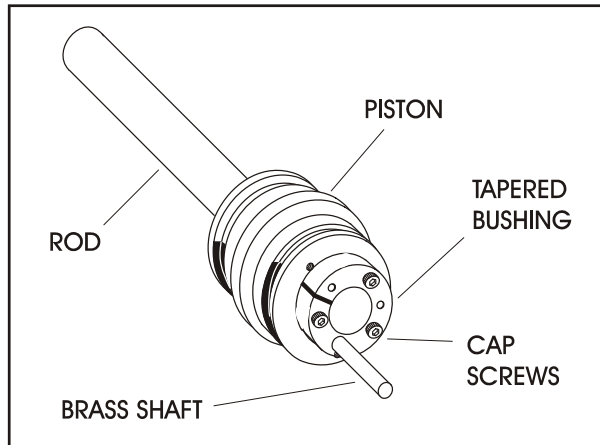

Figure 5-21. Seating the Tapered Bearing

14. Retorque the cap screws evenly and progressively in rotation to the specified torque value. (See Table 5-1, Cylinder Head and Tapered Bushing Torque Specifications.)
15. Remove the cylinder rod from the holding fixture.
16. Place new guide locks and seals in the applicable outside diameter grooves of the cylinder piston. (See Figure 5-19., Piston Seal Kit Installation)

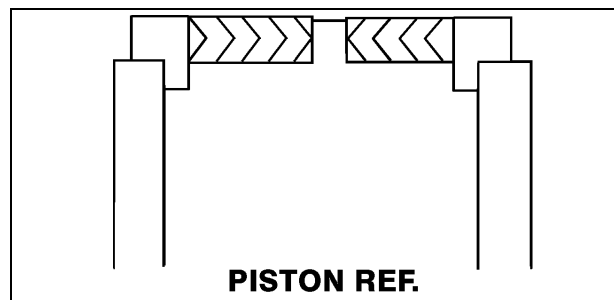

Figure 5-22. Poly-Pak Piston Seal Installation

17. Position the cylinder barrel in a suitable holding fixture.

NOTICE

EXTREME CARE SHOULD BE TAKEN WHEN INSTALLING THE CYLINDER ROD, HEAD, AND PISTON. AVOID PULLING THE ROD OFF-CENTER, WHICH COULD CAUSE DAMAGE TO THE PISTON AND CYLINDER BARREL SURFACES.

18. With barrel clamped securely, and while adequately supporting the rod, insert the piston end into the barrel cylinder. Ensure that the piston loading o-ring and seal ring are not damaged or dislodged.

19. Continue pushing the rod into the barrel until the cylinder head gland can be inserted into the barrel cylinder.
20. Secure the cylinder head gland using the washer ring and socket head bolts.

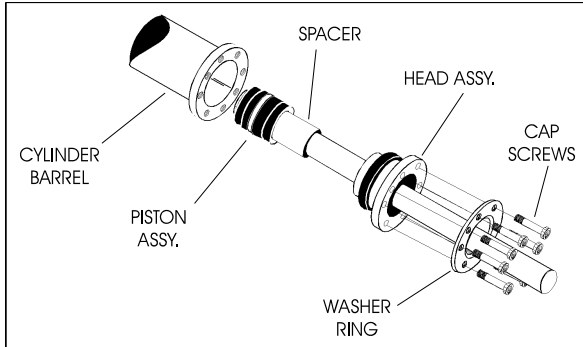

Figure 5-23. Rod Assembly Installation

21. After the cylinder has been reassembled, the rod should be pushed all the way in (fully retracted) prior to the reinstallation of any holding valve or valves.
22. If applicable, install the cartridge-type holding valve and fittings in the rod port block, using new o-rings as applicable. (See Table 5-3, Holding Valve Torque Specifications).

IF THE CYLINDER IS TO BE TESTED PRIOR TO INSTALLATION ON THE MACHINE, EXTREME CARE SHOULD BE USED TO INSURE THAT THE OUTER END OF THE ROD IS SUPPORTED. USE EITHER A TRAVELING OVERHEAD HOIST, FORK-LIFT, OR OTHER MEANS TO SUPPORT THE OVERHANGING WEIGHT OF THE EXTENDING ROD.

Table 5-1. Cylinder Head and Tapered Bushing Torque Specifications

Description	Head Torque Value (Wet)	Tapered Bushing Torque Value (Wet)
Jib. Cylinder	41 Nm (30 ft. lbs.)	7 Nm (5 ft. lbs.)
Level Cylinder	41 Nm (30 ft. lbs.)	7 Nm (5 ft. lbs.)
Master Cylinder	41 Nm (30 ft. lbs.)	7 Nm (5 ft. lbs.)
Master Cylinder E/M400A, E/M450A,	108 Nm (80 ft. lbs.)	N/A

Table 5-2. Cylinder Piston Nut Torque Specifications

Description	Nut Torque Valve (Wet)	Setscrew Torque Value (Dry)
Upper Lift Cylinder	200 ft. lbs. (270Nm)	100 in. lbs. (11 Nm)
Mid Lift Cylinder	400 ft. lbs. (542 Nm)	100 in. lbs. (11 Nm)
Mid Lift Cylinder E400An	200 ft. lbs. (270 Nm)	100 in. lbs. 11 (Nm)
Lower Lift Cylinder	400 ft. lbs. (542 Nm)	100 in. lbs. (11 Nm)

Table 5-3. Holding Valve Torque Specifications

Description	Torque Value
SUN - 7/8 HEX M20 X 1.5 THDS.	30-35 ft. lbs. (41-48 Nm)
SUN - 1 1/8 HEX 1 -14 UNS THDS.	45-50 ft. lbs. (61-68 Nm)
SUN - 1 1/4 HEX M36 X 2 THDS.	150-160 ft. lbs. (204-217 Nm)
RACINE - 1 1/8 HEX 1 1/16 - 12 THDS.	50-55 ft. lbs. (68-75 Nm)
RACINE - 1 3/8 HEX 1 3/16 - 12 THDS.	75-80 ft. lbs. (102-109 Nm)
RACINE - 1 7/8 HEX 1 5/8 - 12 THDS.	100-110 ft. lbs. (136-149 Nm)

5.5 PRESSURE SETTING PROCEDURES

Cold temperatures have a significant impact on pressure readings. JLG Industries Inc. recommends operating the machine until hydraulic system has warmed to normal operating temperatures prior to checking pressures. We also recommend using a calibrated gauge. Pressure readings are acceptable if within +/- 5% of specified pressures.

Main Relief

1. Install pressure gauge at port "G" on Steer/Brake valve.
2. Activate and bottom out either Upper or Lower Lift Up. Adjust Main Relief to value given in Table 5-4, Pressure Settings - Prior to S/N 0300062642 or Table 5-5, Pressure Settings - S/N 0300062642 to Present.

Upper Lift Down Relief

1. With pressure gauge at "G" port on main valve, activate and bottom out Upper Lift Down.
2. Adjust Upper Lift Relief to value given in Table 5-4, Pressure Settings - Prior to S/N 0300062642 or Table 5-5, Pressure Settings - S/N 0300062642 to Present.

Lower Lift Down Relief

1. With pressure gauge at "G" port on main valve, activate and bottom out Mid/Lower Lift Down.
2. Adjust Mid/Lower Lift Relief to value given in Table 5-4, Pressure Settings - Prior to S/N 0300062642 or Table 5-5, Pressure Settings - S/N 0300062642 to Present.

Telescope Relief

1. With pressure gauge at "G" port on main valve, activate and bottom out Telescope In.
2. Adjust Telescope Relief to value given in Table 5-4, Pressure Settings - Prior to S/N 0300062642 or Table 5-5, Pressure Settings - S/N 0300062642 to Present.

Platform Level Up Relief

1. On machines prior to S/N 0300062642, install the pressure gauge at the "G" port on Main Control valve, activate and bottom out Platform Level Up.

On machines S/N 0300062642 to present, install the pressure gauge at the "B2" port on the back of the Main Control Valve, activate and bottom out Platform Level Up.

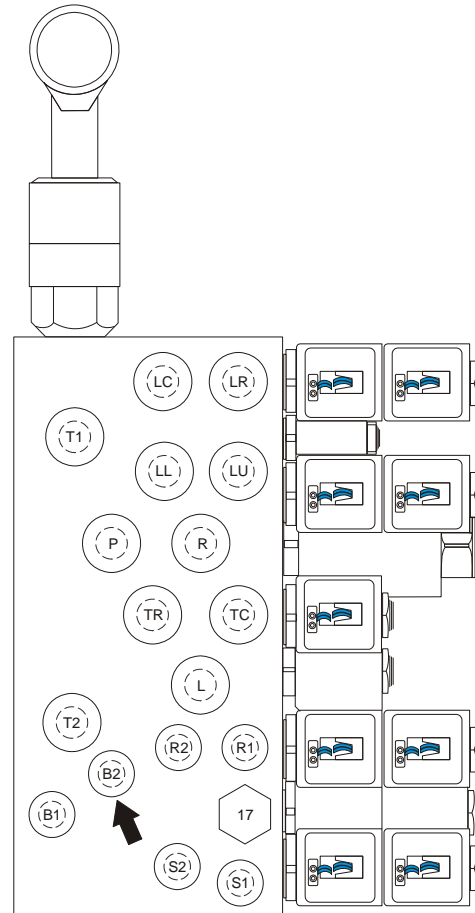

2. Adjust Platform Level Up Relief to value given in Table 5-4, Pressure Settings - Prior to S/N 0300062642 or Table 5-5, Pressure Settings - S/N 0300062642 to Present.

Platform Level Down Relief

1. On machines prior to S/N 0300062642, install the pressure gauge at the "G" port on Main Control valve, activate and bottom out Platform Level Down.

On machines S/N 0300062642 to present, install the pressure gauge at the "B1" port on the back of the Main Control Valve, activate and bottom out Platform Level Down.

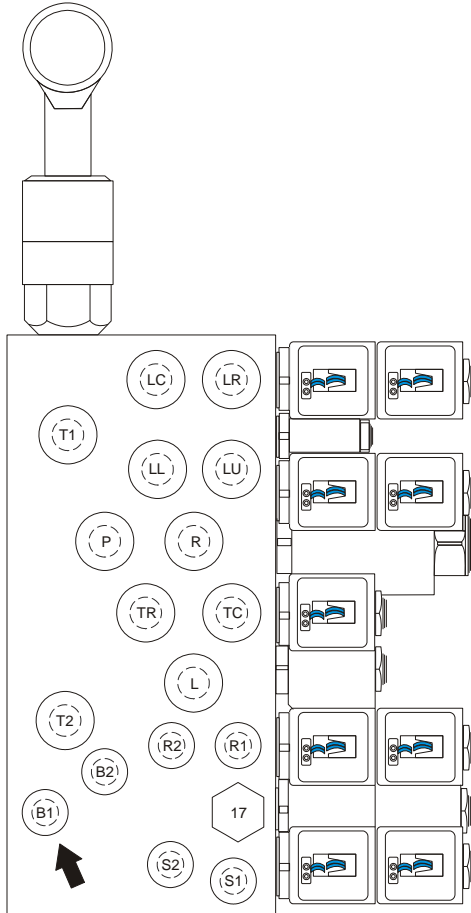

2. Adjust Platform Level Down Relief to value given in Table 5-4, Pressure Settings - Prior to S/N 0300062642 or Table 5-5, Pressure Settings - S/N 0300062642 to Present.

Steer Relief

1. With pressure gauge at "G" port on steer/brake valve, activate and bottom out Steer Left or Right.
2. Adjust Steer Relief to value given in Table 5-4, Pressure Settings - Prior to S/N 0300062642 or Table 5-5, Pressure Settings - S/N 0300062642 to Present.
3. Shut down hydraulic system and remove pressure gauge.

Jib Lift (Up and Down) Relief

1. Install the pressure gauge at the at the "G" port on the Main Control valve, activate and bottom out jib up or down.
2. Adjust the Jib Lift pressure to the value given in Table 5-4, Pressure Settings - Prior to S/N 0300062642 or Table 5-5, Pressure Settings - S/N 0300062642 to Present.

Jib Swing Relief

1. Install the pressure gauge at the at the "G" port on the Main Control valve, activate and bottom out jib swing left or right.
2. Adjust the Jib Swing pressure to the value given in Table 5-4, Pressure Settings - Prior to S/N 0300062642 or Table 5-5, Pressure Settings - S/N 0300062642 to Present.

Releveling Valve Relief

1. Install a pressure gauge at port "G" on the main valve.
2. Adjust the lower lift down pressure relief to the value given in Table 5-4, Pressure Settings - Prior to S/N 0300062642 or Table 5-5, Pressure Settings - S/N 0300062642 to Present.
3. With the lower boom lowered all the way, pull the red releveling knob and activate lower lift down.
4. Adjust the releveling pressure relief to the value given in Table 5-4, Pressure Settings - Prior to S/N 0300062642 or Table 5-5, Pressure Settings - S/N 0300062642 to Present. Turning clockwise increases the pressure and turning counterclockwise decreases pressure. The relief valve is located directly below the red releveling knob.

SECTION 5 - HYDRAULICS

Table 5-4. Pressure Settings - Prior to S/N 0300062642

Circuit	PSI	Bar
Main Control Valve		
Lift Down Relief	550	38
Tower Lift Down Relief	1700	117
Telescope In Relief (A/AJ)	2150	148
Telescope In Relief (AJP)	3000	207
Platform Level Up Relief	2500	172
Platform Level Down Relief	1500	103
Brake/Steer Valve		
Steer Relief	2300	159
Steer Relief - AJPn	1100	76
Main Relief - E400A/M400A	3200	221
Main Relief - E400AJ/M400AJ	3400	234
Jib Valve		
Jib Relief (Up and Down)	1500	103
Jib Swing Relief	3000	207
Releving Valve		
Releving Relief	1200	83

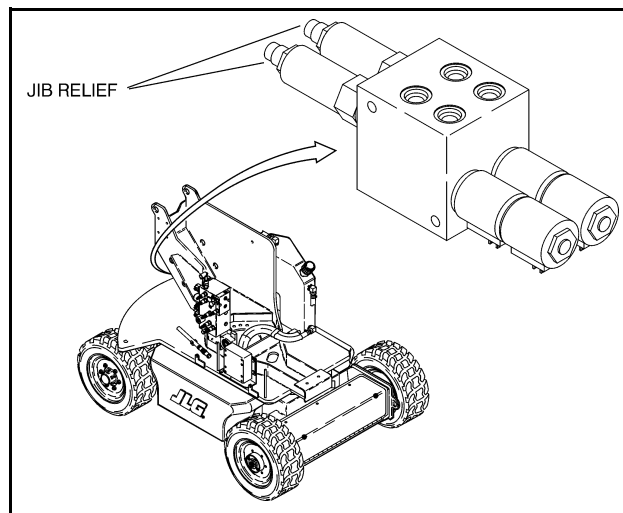

Figure 5-24. Jib Valve Location

Table 5-5. Pressure Settings - S/N 0300062642 to Present

Circuit	PSI	Bar
Main Control Valve		
Lift Down Relief	800	55
Tower Lift Down Relief (E/M400A) Prior to S/N 86022	1700	117
Tower Lift Down Relief (E/M400A) S/N 86022 to Present	2600	179
Tower Lift Down Relief (E/M400AJP) Prior to S/N 91053	1700	117
Tower Lift Down Relief (E/M400AJP) S/N 91053 to Present	2600	179
Telescope Relief (A)	3000	207
Telescope Relief (AJ & AJP)	3100	214
Platform Level Up Relief	3000	207
Platform Level Down Relief	1200	83
Brake/Steer Valve		
Steer Relief - AJP/A	2300	159
Steer Relief - An	1100	76
Steer Relief - AJPn	1400	96.5
Main Relief	3400	234
Jib Valve		
Jib Relief Up	2200	152
Jib Swing Relief	3000	207
Releving Valve		
Releving Relief (E/M400A) Prior to S/N 86022	1200	83
Releving Relief (E/M400A) S/N 86022 to Present	2200	152
Releving Relief (E/M400AJP) Prior to S/N 91053	1200	83
Releving Relief (E/M400AJP) S/N 91053 to Present	2200	152

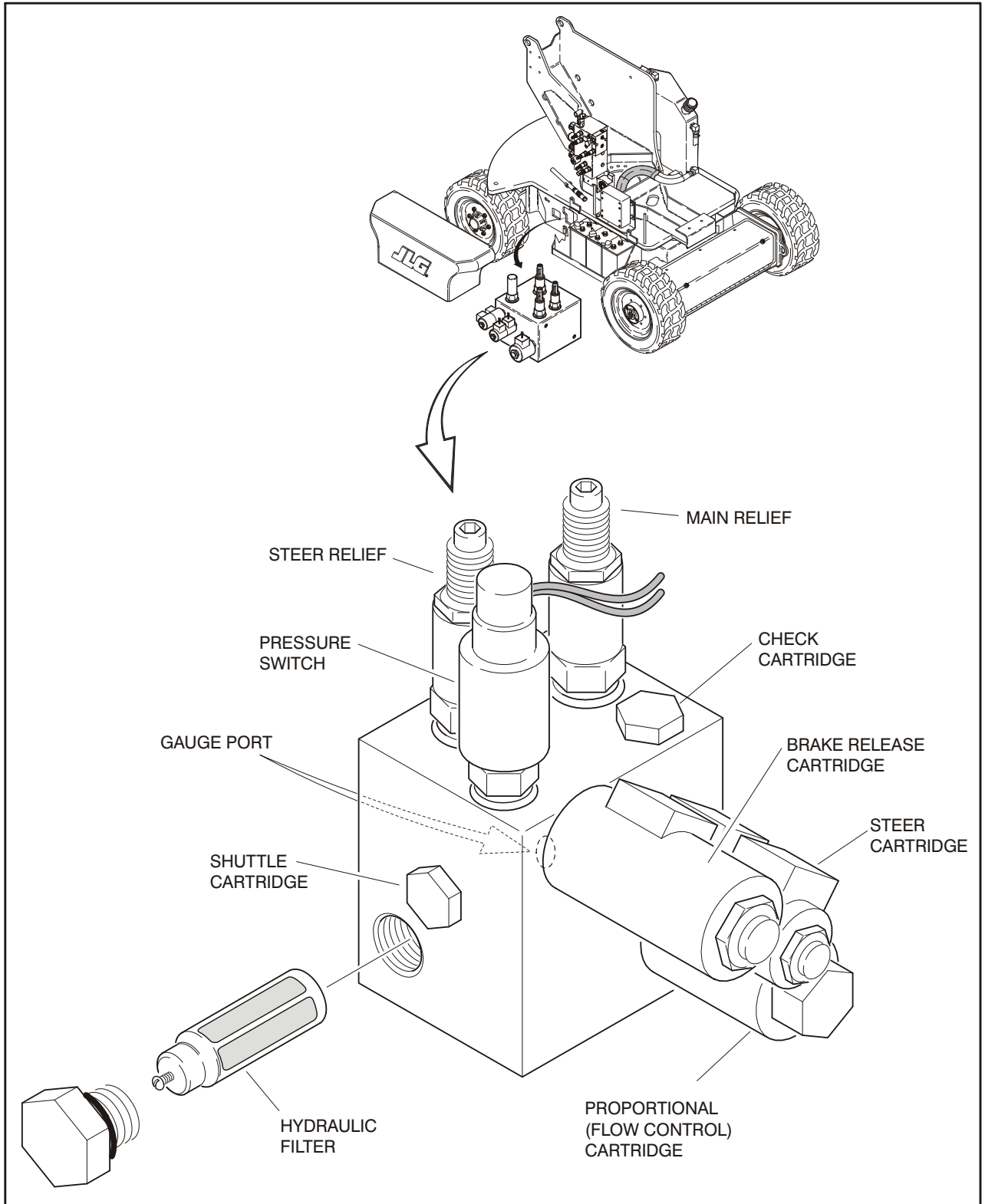

Figure 5-25. Brake/Steer Valve Components

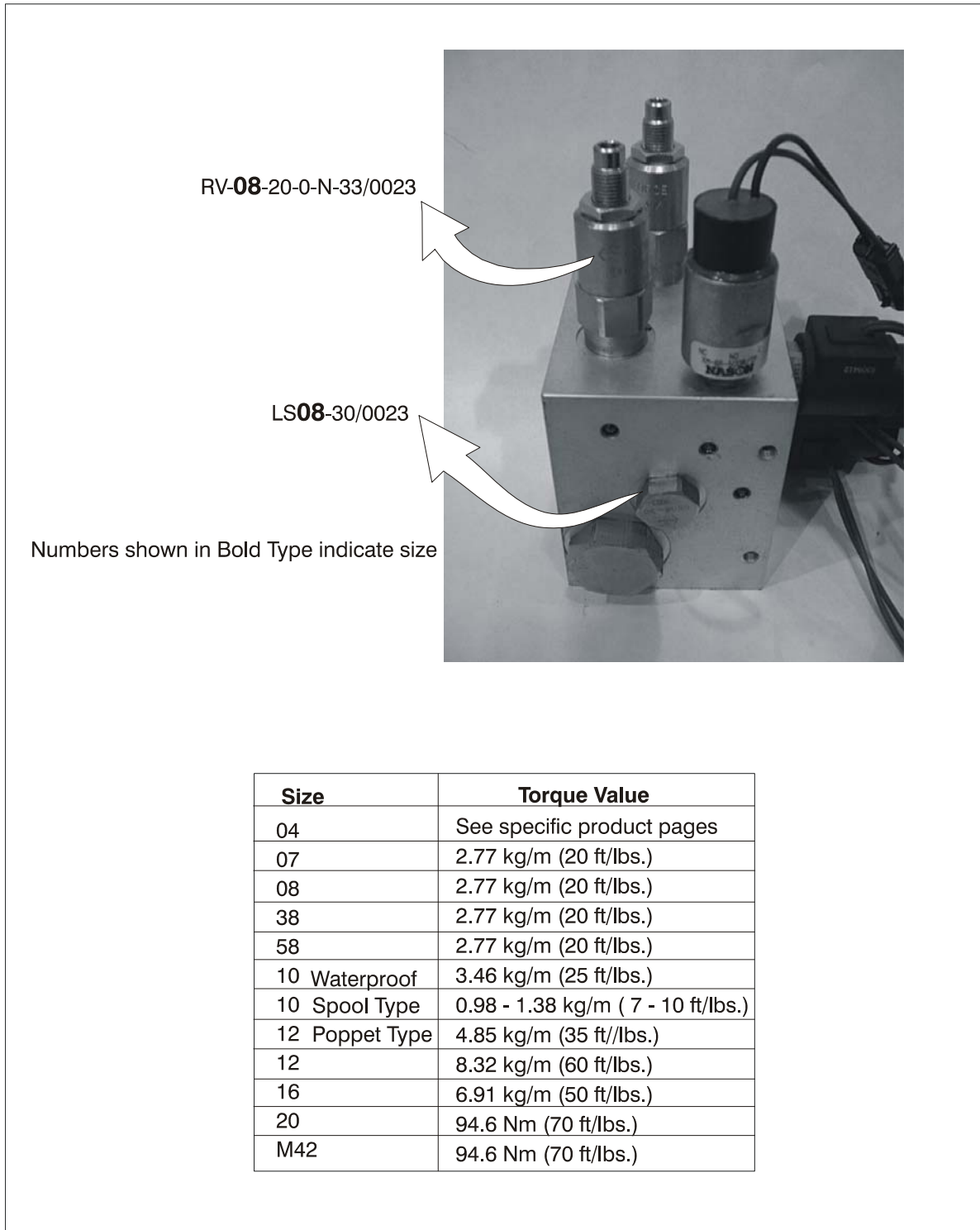

Figure 5-26. HydraForce Cartridge Torque Value Chart

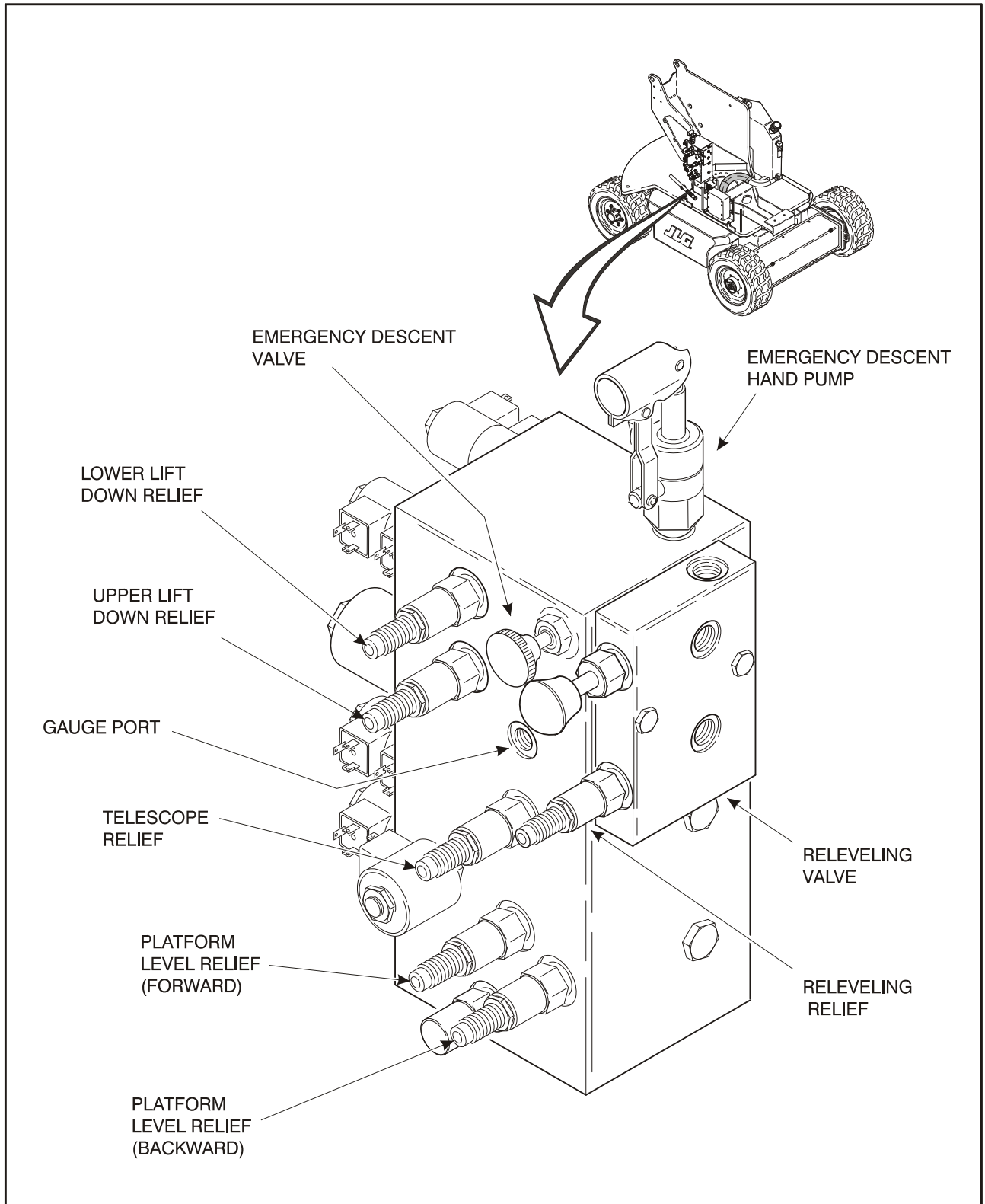

Figure 5-27. Main Valve Components Prior to S/N 62642

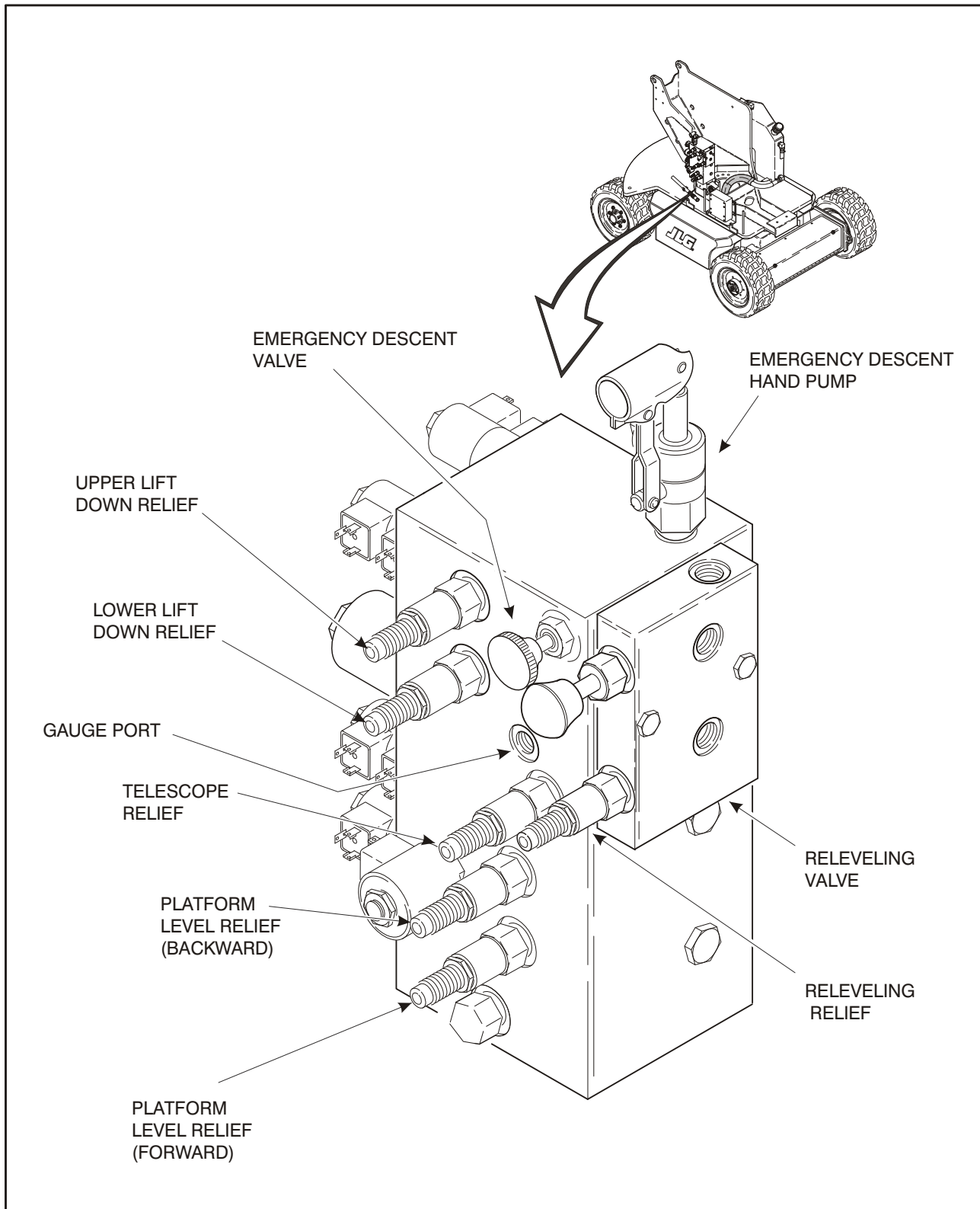

Figure 5-28. Main Valve Components S/N 62642 to Present

SECTION 6. JLG CONTROL SYSTEM

6.1 JLG CONTROL SYSTEM ANALYZER KIT INSTRUCTIONS

Introduction

NOTICE

WHEN INSTALLING A NEW POWER MODULE CONTROLLER ON THE MACHINE, IT WILL BE NECESSARY TO PROGRAM THE CONTROLLER FOR THE PROPER MACHINE CONFIGURATION, INCLUDING OPTIONS.

NOTICE

IT IS A GOOD PRACTICE TO AVOID PRESSURE-WASHING ELECTRICAL/ELECTRONIC COMPONENTS. SHOULD PRESSURE-WASHING BE UTILIZED TO WASH AREAS CONTAINING ELECTRICAL/ELECTRONIC COMPONENTS, JLG INDUSTRIES, INC. RECOMMENDS A MAXIMUM PRESSURE OF 750 PSI (52 BAR) AT A MINIMUM DISTANCE OF 12 INCHES (30.5 CM) AWAY FROM THESE COMPONENTS. IF ELECTRICAL/ELECTRONIC COMPONENTS ARE SPRAYED, SPRAYING MUST NOT BE DIRECT AND BE FOR BRIEF TIME PERIODS TO AVOID HEAVY SATURATION.

The JLG designed Control System is a 48 volt based motor control unit installed on the boom lift.

The JLG Control System has reduced the need for exposed terminal strips, diodes and trimpots and provides simplicity in viewing and adjusting the various personality settings for smooth control of: acceleration, deceleration, creep and max.-speed for all boom, drive, and steering functions.

The upper lift, swing, and drive are controlled by individual joysticks, with steering being controlled by a rocker switch built into the top the drive joystick. To activate Drive, Lift, and Swing simply pull up on the slide lock location on the joystick and move the handle into the direction desired.

The motor controller will control current output, as programmed for smooth operation and maximum cycle time. Ground control speeds for all boom functions can also be programmed into the motor controller. The motor controller also features an adjustable time limit for positive traction.

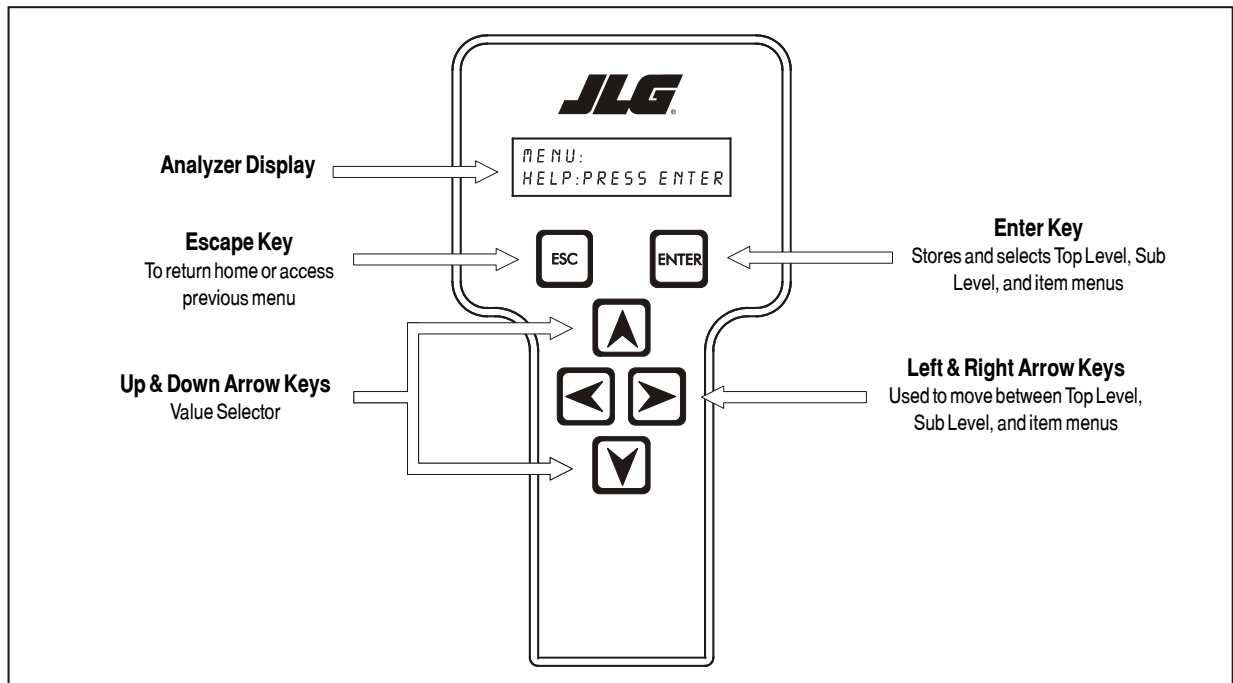

Figure 6-1. Hand Held Analyzer

SECTION 6 - JLG CONTROL SYSTEM

The JLG Control System controller has a built in LED to indicate any faults. The system stores recent faults which may be accessed for troubleshooting. Optional equipment includes an hour meter, beacon light, function cut-out, and ground alarm. These options may be added later but must be programmed into the motor controller when installed.

The Control System may be accessed in one of two ways: Utilizing a custom designed, hand held analyzer (Analyzer, JLG part no. 1600244 & Cable, JLG part no. 1600633) which will display two lines of information at a time, by scrolling through the program.

NOTE: Each module has a label with the JLG part number and a serial number which contains a date code.

The following instructions are for using the hand held analyzer.

To Connect the JLG Control System Analyzer

1. Connect the four pin end of the cable supplied with the analyzer, to the motor controller module located in the platform box or at the power module and connect the remaining end of the cable to the analyzer.

NOTE: The cable has a four pin connector at each end of the cable; the cable cannot be connected backwards.

2. Power up the Control System by turning the lower key to the platform or ground position and pulling both emergency stop buttons on.

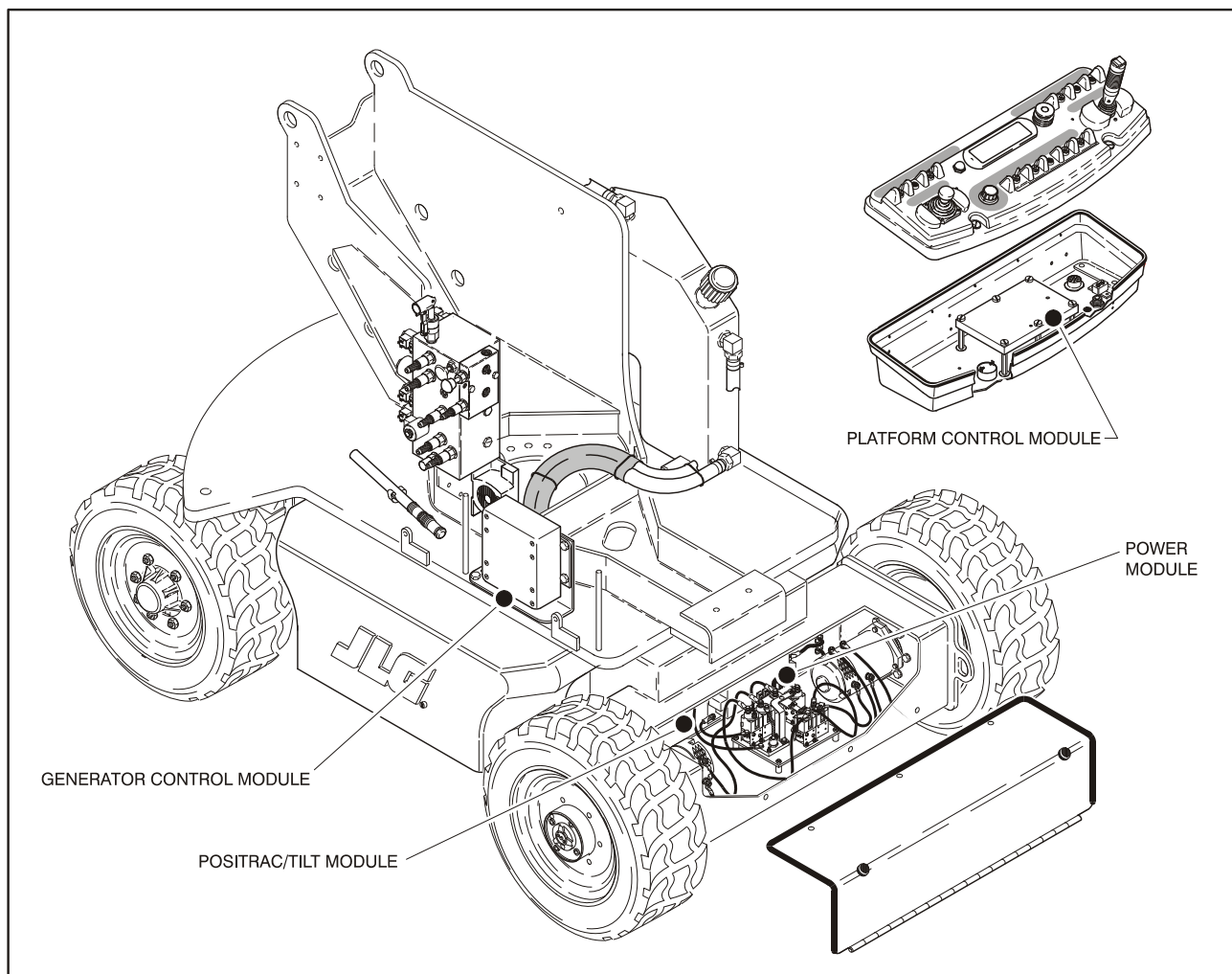
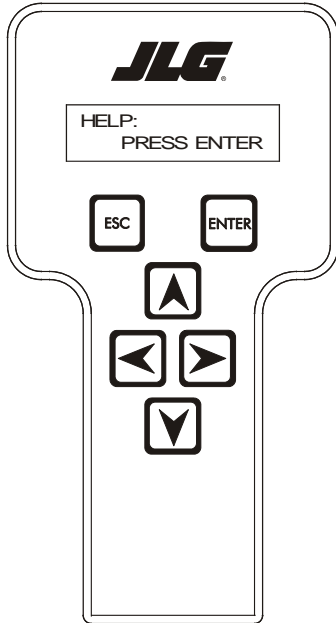

Figure 6-2. Control Module Location

Using the Analyzer

With the machine power on and the analyzer connected properly, the analyzer will display the following:



**HELP:
PRESS ENTER**

At this point, using the **RIGHT** and **LEFT** arrow keys, you can move between the top level menu items. To select a displayed menu item, press **ENTER**. To cancel a selected menu item, press **ESC**.; then you will be able to scroll using the right and left arrow keys to select a different menu item.

The top level menus are as follows:

**HELP
DIAGNOSTICS
ACTIVATE TEST
ACCESS LEVEL
PERSONALITIES
MACHINE SETUP
LEVEL VEHICLE (level 1 only)
CALIBRATIONS (view only)**

If you press **ENTER**, at the **HELP: PRESS ENTER** display, and a fault is present, the analyzer display will scroll the fault across the screen. If there was no fault detected, the display will read: **HELP: EVERYTHING OK**. If powered up at the ground station, the display will read: **GROUND OK**.

If **ENTER** is pressed again, the display moves to the following display:

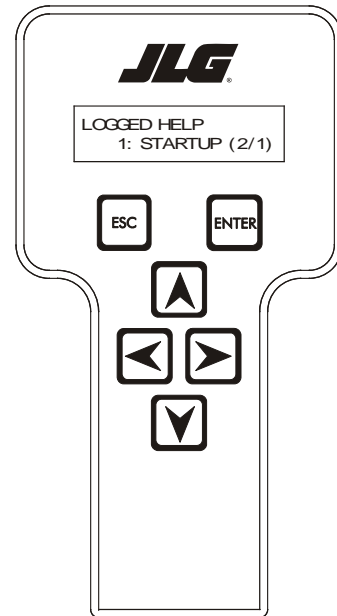

**LOGGED HELP
1: STARTUP (2/1)**

At this point, the analyzer will display the last fault the system has seen, if any are present. You may scroll through the fault logs to view what the last 25 faults were. Use the right and left arrow keys to scroll through the fault logs. To return to the beginning, press **ESC**. two times. **STARTUP (2/1)** indicates a power up.

When a top level menu is selected, a new set of menu items may be offered: for example:

**DRIVE
BOOM
SYSTEM
DATALOG
VERSIONS**

Pressing **ENTER** with any of the above displayed menus, will display additional sub-menus within the selected menu. In some cases, such as **DRIVE**, the next level is the parameter or information to be changed. Refer to the flow chart for what menus are available within the top level menus. You may only view the personality settings for selected menus while in access level 2. Remember, you may always cancel a selected menu item by pressing the **ESC**. key.

Changing the Access Level of the Hand Held Analyzer

When the analyzer is first connected, you will be in access level 2 which enables you to only view most settings which cannot be changed until you enter a password to advance to a lower level. This ensures that a setting cannot be accidentally altered. To change the access level, the correct password must be entered. To enter the password, scroll to the **ACCESS LEVEL** menu. For example:

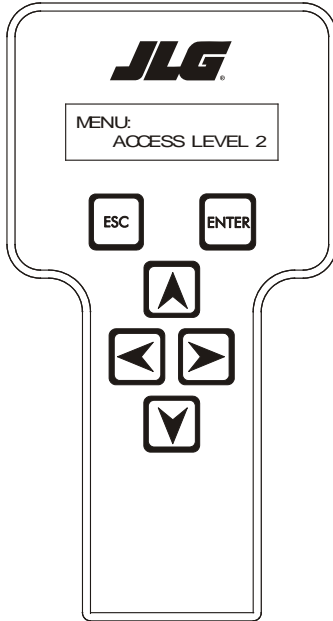

**MENU:
ACCESS LEVEL 2**

Press **ENTER** to select the **ACCESS LEVEL** menu.

Using the **UP** or **DOWN** arrow keys, enter the first digit of the password, 3.

Then using the **RIGHT** arrow key, position the cursor to the right one space to enter the second digit of the password.

Use the **UP** or **DOWN** arrow key to enter the second digit of the password which is 33271.

Once the correct password is displayed, press **ENTER**. The access level should display the following, if the password was entered correctly:

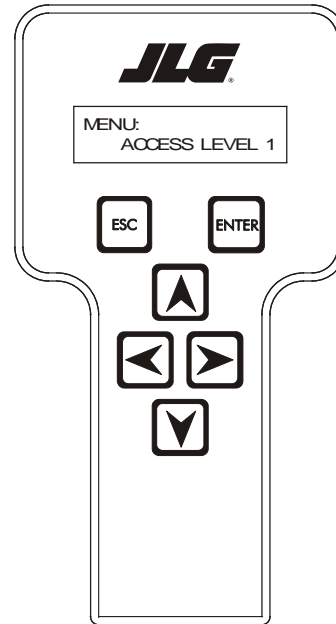

**MENU:
ACCESS LEVEL 1**

Repeat the above steps if the correct access level is not displayed or you can not adjust the personality settings.

Adjusting Parameters Using the Hand Held Analyzer

Once you have gained access to level 1, and a personality item is selected, press the UP or DOWN arrow keys to adjust its value, for example:

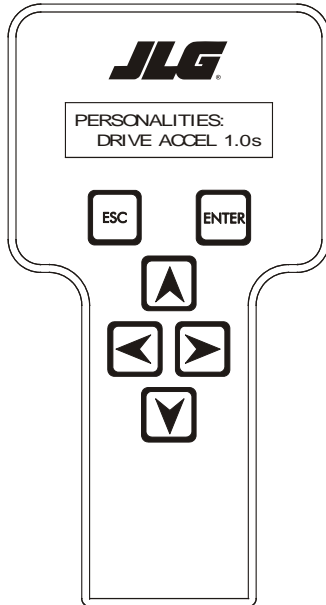

**PERSONALITIES:
DRIVE ACCEL 1.0s**

There will be a minimum and maximum for the value to ensure efficient operation. The Value will not increase if the **UP** arrow is pressed when at the maximum value nor will the value decrease if the **DOWN** arrow is pressed and the value is at the minimum value for any particular personality. If the value does not change when pressing the up and down arrows, check the access level to ensure you are at access level 1.

Machine Setup

When a machine digit item is selected, press the UP or DOWN arrow keys to adjust its value, for example:

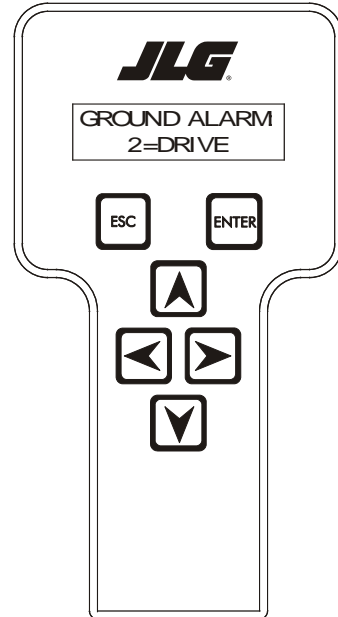

**GROUND ALARM:
2 = DRIVE**

SECTION 6 - JLG CONTROL SYSTEM

The effect of the machine digit value is displayed along with its value. The above display would be selected if the machine was equipped with a ground alarm and you wanted it to sound when driving. There are certain settings allowed to install optional features or select the machine model.

When selection the machine model to match the size of the machine, the personality settings will all default to the factory recommended setting.

NOTE: Refer to Table 6-1, Personality Ranges/Defaults, and Table 6-2, Machine Setup Descriptions in this Service Manual for the recommended factory settings.

NOTE: Password 33271 will give you access to level 1, which will permit you to change all machine personality settings.

There is a setting that JLG strongly recommends that you do not change. This setting is so noted below:

ELEVATION CUTBACK

WARNING

CHANGING THIS SETTING MAY ADVERSELY AFFECT THE PERFORMANCE OF YOUR MACHINE.

NOTICE

IT IS A GOOD PRACTICE TO AVOID PRESSURE-WASHING ELECTRICAL/ELECTRONIC COMPONENTS. SHOULD PRESSURE-WASHING BE UTILIZED TO WASH AREAS CONTAINING ELECTRICAL/ELECTRONIC COMPONENTS, JLG INDUSTRIES INC. RECOMMENDS A MAXIMUM PRESSURE OF 750 PSI (52 BAR) AT A MINIMUM DISTANCE OF 12 INCHES (30.5CM) AWAY FROM THESE COMPONENTS. IF ELECTRICAL/ELECTRONIC COMPONENTS ARE SPRAYED, SPRAYING MUST NOT BE DIRECT AND BE FOR BRIEF TIME PERIODS TO AVOID HEAVY SATURATION.

Machine Personality Settings

NOTE: Personality settings can be adjusted within the adjustment range in order to achieve optimum machine performance.

Table 6-1. Personality Ranges/Defaults

FUNCTION	PERSONALITY	RANGE	DEFAULTS
DRIVE	ACCEleration	0.5s to 5.0s	1.0
	DECEleration	0.1s to 2.0s	0.5
	MINimum speed	0 to 25%	3
	MAXimum speed	0 to 100%	100
	ELEVATED MAXimum speed	0 to 25%	20
	CREEP MAXimum speed	0 to 45%	30
	POSITRAC time	0 to 60s	10
	POSITRAC current	50-250 A	170A
LOWER LIFT	ACCEleration	0.5 to 5.0s	1.0
	DECEleration	0.0 to 3.0s	0.5
	MINimum UP speed	0 to 30%	19
	MAXimum UP speed	0 to 100%	95
	MINimum DOWN speed	0 to 20%	7
	MAXimum DOWN speed	0 to 100%	47
UPPER LIFT	ACCEleration	0.5 to 5.0	2.0
	DECEleration	0.1 to 3.0	1.0
	MINimum UP speed	0 to 20	9
	MAXimum UP speed	0 to 100	67
	CREEP Maximum UP speed	0 to 50	30
	MINimum DOWN speed	0 to 10	2
	MAXimum DOWN speed	0 to 100	40
	CREEP maximum DOWN speed	0 to 30	10
SWING	ACCEleration	0.5 to 5.0s	2.7
	DECEleration	0.1 to 3.0s	1.8
	MINimum LEFT speed	0 to 10%	1
	MAXimum LEFT speed	0 to 60%	25
	CREEP maximum LEFT speed	0 to 35%	15
	MINimum RIGHT speed	0 to 10%	1
	MAXimum RIGHT speed	0 to 60%	25
	CREEP maximum RIGHT speed	0 to 35%	15

SECTION 6 - JLG CONTROL SYSTEM

Table 6-1. Personality Ranges/Defaults

FUNCTION	PERSONALITY	RANGE	DEFAULTS
TELEscope	ACCEleration	0.5 to 5.0	1.0
	DECEleration	0.1 to 3.0	0.5
	MINimum IN speed	0 to 20	8
	MAXimum IN speed	0 to 100	60
	MINimum OUT speed	0 to 20	5
	MAXimum OUT speed	0 to 100	70
BASKET LEVEL	ACCEleration	0.5 to 5.0	1.0
	DECEleration	0.1 to 3.0	1.0
	MINimum UP speed	0 to 20	8
	MAXimum UP speed	0 to 50	20
	MINimum DOWN speed	0 to 20	5
	MAXimum DOWN speed	0 to 60	14
BASKET ROTATE	ACCEleration	0.5 to 5.0	1.5
	DECEleration	0.1 to 3.0	1.0
	MINimum LEFT speed	0 to 15	2
	MAXimum LEFT speed	0 to 100	23
	MINimum RIGHT speed	0 to 15	2
	MAXimum RIGHT speed	0 to 100	27
JIB	ACCEleration	0.5 to 5.0	1.5
	DECEleration	0.1 to 3.0	0.5
	MINimum UP speed	0 to 50	9
	MAXimum UP speed	0 to 100	50
	MINimum DOWN speed	0 to 25	6
	MAXimum DOWN speed	0 to 100	35
	MINimum RIGHT speed	0 to 50	5
	MAXimum RIGHT speed	0 to 100	20
	MINimum LEFT speed	0 to 50	5
	MAXimum LEFT speed	0 to 100	20
STEER	MINimum speed	0 to 100	75
	MAXimum speed	0 to 100	100

Table 6-1. Personality Ranges/Defaults

FUNCTION	PERSONALITY	RANGE	DEFAULTS
GROUND MODE	Lower LIFT UP speed	0 to 100	73
	Lower LIFT DOWN speed	0 to 100	36
	UPPER LIFT speed	0 to 100	51
	SWING speed	0 to 100	19
	TELEscope speed	0 to 100	53
	BASKET ROTATE speed	0 to 100	21
	BASKET LEVEL speed	0 to 100	30
	JIB SWING speed	0 to 100	42
	JIB LIFT speed	0 to 100	45

4150285-6

Table 6-2. Machine Setup Descriptions

MODEL NUMBER...	Displays/adjusts machine model NOTE: all personalities reset to default when model number is altered
TILT...	Displays/adjusts tilt sensor function
DRIVE CUTOUT...	Displays/adjusts drive cutout switch presence/function
FUNCTION CUTOUT...	Displays/adjusts function cutout switch presence/function
JIB...	Displays/adjusts jib presence
GROUND ALARM...	Displays/adjusts ground alarm presence/function
PLATFORM ALARM...	Displays/adjusts platform alarm presence/function
BATTERY MONITOR...	Displays/adjusts battery monitor, which indicates "WATER BATTERIES" after a number of charge/discharge cycles

Machine Configuration Programming Information

4150286-9

NOTE: The following information is to be used when working with the MACHINE SETUP menu. When configuring the machine, the machine configuration must be completed before any personality settings can be changed. Changing the personality settings first and then changing the model number of the machine configuration will cause the personality settings to return to default values.

Default settings will be shown in bold type.

1. MODELS (names may change)

- 1=Model E300**
- 2=Model 400*
- 3 = Model 45/450*

* The elevated drive speed setting must be changed to 10% for E45AJ, M45AJ, M40AJP, E40AJP, M450AJ, E450AJ, M400AJP, E400AJP, E400A, and M400A machines going to Europe (CE). Also the elevated drive speed setting must be changed to 15% for E40AJPn, M40APn, E400AJP narrow, M400AJPn, E400A narrow, and M400A narrow machines going to Europe (CE).

1. TILT SWITCH

When tilted the tilt light is lit (continuously) and drive speed is reduced to the creep speed setting

1=5 degree - reduces the maximum speed of all platform functions to creep when tilted and above elevation. Reduces drive speed to creep when tilted. (Domestic/Japan)

2=3 degree - reduces the maximum speed of all platform functions to creep when tilted and above elevation. Reduces drive speed to creep when tilted. (European/Australian)

3=3 degree - cuts out drive and reduces functions to creep speed when tilted and above elevation. Reduces drive speed to creep when tilted only. (Option)

NOTE: Any of the selections above will light the tilt lamp when a tilted condition occurs and will sound the platform alarm when the machine is tilted and above elevation.

2. DRIVE CUTOUT

0=Battery Charger Cutout - cuts out drive when the battery charger is plugged in

1= Battery Charger Cutout and Simultaneous Drive and Boom functions disabled above elevation (European/Australian)

2= Battery Charger Cutout and Drive Cutout above elevation (Option)

3. FUNCTION CUTOUT LIMIT SWITCH

0= No Function Cutout

1= Cuts out all boom functions when switch opens (Option)

2= Cuts out all functions when the switch opens (Option)

4. JIB

0=No jib installed

1=Jib installed which has up and down movements only (Option)

2=Jib installed which has up and down movements and side to side movements (Option)

5. GROUND ALARM

0= No ground alarm installed

1= Travel Alarm - Sounds when the drive function is active (Option)

2= Descent Alarm - Sounds when either lift down is active (Option)

3= Motion Alarm - Sounds when any function is active (Option)

6. PLATFORM ALARM

0= Sounds continuously when above elevation and tilted only.

1= Sounds continuously when above elevation and tilted, and in conjunction with fault code flashes (Option)

7. SOFT TOUCH

0=No Soft Touch System Installed

1= Soft-Touch System Installed

8. LOAD CELL

0=No Load Cell Installed

1= Warn Only

2 = Warn & Cutout

3 = Warn & Boom Cutout

Level Vehicle Description

NOTICE

A NEW TILT MODULE WILL ACT AS IF IT IS TILTED ALL OF THE TIME UNTIL THE FOLLOWING PROCEDURE IS PERFORMED.

WARNING

DO NOT LEVEL VEHICLE EXCEPT ON A LEVEL SURFACE.

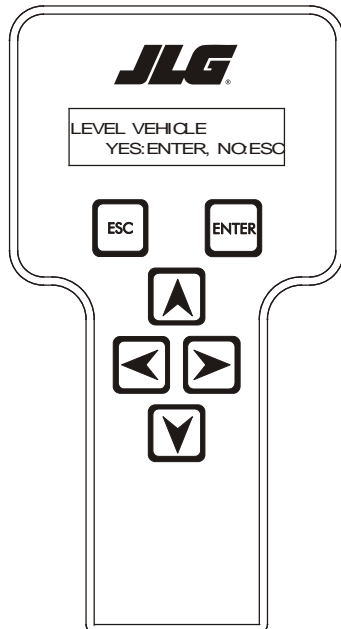

LEVEL VEHICLE
YES:ENTER, NO:ESC

Not available at password level 2 ENTER confirms that vehicle is currently level, and zeroes the tilt sensor measurements

Help Descriptions and Fault Flash Codes

Table 6-3. JLG Control System Flash Codes

Code	Description
2-1	Faulty Foot switch/EMS
2-2	Drive/Steer inputs/Foot switch Interlocks
2-3	Boom function inputs/Lift-Swing Joystick
2-5	Function Cutout/Drive Cutout
3-1	Contactors miswired/Motors miswired
3-2	Line contactor welded
3-3	Contactors short circuit or valve short circuit
3-5	Brake pressure input
4-2	Controller Over temperature
4-4	Battery voltage out of range
5-5	Speed Sensor input
6-6	CANbus inputs
7-7	Traction /Pump motor wiring or motor faulty
9-9	Power Module Failure

SECTION 6 - JLG CONTROL SYSTEM

Table 6-4. Help Descriptions and Fault Flash Codes

Flash Code	Description
No flash code is indicated for the following help messages; they are intended to hint at a possible problem if the vehicle is not behaving as expected.	
	EVERYTHING OK The “normal” help message in platform mode
	GROUND MODE OK The “normal” help message in ground mode
	BRAKES RELEASED Indicates manual brake release in ground mode
	DRIVING AT CREEP - TILTED Drive speed is limited to creep because the vehicle is tilted.
	FWS OPEN A drive or boom function has been selected but footswitch is open.
	PUMP MOTOR AT CURRENT LIMIT Pump current has reached controller current limit or safe operating area limit.
	RUNNING AT CREEP - CREEP SWITCH OPEN All function speeds are limited to creep because the creep switch is open.
	RUNNING AT CUTBACK - ABOVE ELEVATION All function speeds are limited to cutback speed because the vehicle is above elevation.
	RUNNING AT CREEP - TILTED AND ABOVE ELEVATION All function speeds are limited to creep because the vehicle is tilted and above elevation.
	TESTS ACTIVE - RECYCLE EMS TO END The system tests have been activated; normal vehicle operation is not allowed.
	TILT MODULE FAILURE: BAD TILT SENSOR There is a problem with the tilt sensor interface circuitry; the controller defaults to massively tilted and does not try to prevent vehicle roll on the grade.
	TRACTION MOTOR AT CURRENT LIMIT Traction current has reached controller current limit or safe operating area limit.
	WATER BATTERIES The batteries have been charged a number of times (set by machine digit) and need a top-up; when this is done the count will reset
2/1	Flash code 2/1 indicates problems with the footswitch.
	FWS FAULTY The two footswitch signals do not agree. EMS recycle required.
	START UP Neither EMS input is active - the system is just switching on or is discharging the capacitor bank. A welded line contactor might also cause this

Table 6-4. Help Descriptions and Fault Flash Codes

2/2	Flash code 2/2 indicates problems with drive & steer selection.
	DRIVE JOYSTICK FAULTY The drive joystick center tap is out of valid range, or the wiper is wire-off.
	DRIVE LOCKED - JOYSTICK MOVED BEFORE EMS/FWS Drive was selected before and during footswitch closure.
	FWS INTERLOCK TRIPPED Footswitch was closed for seven seconds with no function selected.
	STEER LOCKED - SELECTED BEFORE EMS/FWS Steer was selected before and during footswitch closure.
	STEER SWITCHES FAULTY Both steer switches are active together.
	WAITING FOR FWS TO BE OPEN Footswitch was closed when platform mode was selected.
	JOYSTICK FAULTS - CHECK PLATFORM BOX WIRING More than one of the drive, lift and swing joystick center tap or wiper voltages is out of range. This is probably due to a short-circuit across a joystick port.
2/3	Flash code 2/3 indicates problems with boom function selection.
	LIFT/SWING JOYSTICK FAULTY The lift or swing Joystick center tap is out of valid range, or the wiper is wire-off.
	LIFT/SWING LOCKED - JOYSTICK MOVED BEFORE EMS/FWS Upper Lift or swing was selected before and during footswitch closure.
	PUMP POT FAULTY The pump pot is open-circuit; all platform boom functions except upper lift & swing will run at creep.
	PUMP SWITCHES FAULTY - CHECK DIAGNOSTICS/BOOM A boom function (lower lift, telescope, basket level, basket rotate, jib) has both directions selected together.
	PUMP SWITCHES LOCKED - SELECTED BEFORE EMS/FWS A boom function (lower lift, telescope, basket level, basket rotate, jib) was selected before and during footswitch closure.
	PUMP SWITCHED LOCKED - SELECTED BEFORE EMS A ground boom function (lower lift, telescope, basket level, basket rotate, jib) was selected before key-switch.
	SWING/LIFT JOYSTICK FAULTY The swing joystick center tap is out of valid range, or the wiper is wire-off.

SECTION 6 - JLG CONTROL SYSTEM

Table 6-4. Help Descriptions and Fault Flash Codes

2/5	Flash code 2/5 indicates that a function is prevented due to a cutout.
	BOOM PREVENTED - DRIVE SELECTED A boom function is selected while a drive function is selected and drive cutout is configured to prevent simultaneous drive & boom operation.
	BOOM PREVENTED - FUNCTION CUTOFF ACTIVE A boom function is selected while function cutout is active and configured to cutout boom functions.
	DRIVE & BOOM PREVENTED - FUNCTION CUTOFF ACTIVE Drive or a boom function is selected while function cutout is active and configured to cutout all functions.
	DRIVE PREVENTED - ABOVE ELEVATION Drive is selected while above elevation and drive cutout is configured to prevent drive.
	DRIVE PREVENTED - BOOM MOVEMENT SELECTED Drive is selected while a boom function is selected and drive cutout is configured to prevent simultaneous drive & boom operation.
	DRIVE PREVENTED - CHARGER CONNECTED Drive is selected while the charger is on (indicated by drive cutout being active) and drive cutout is configured to prevent drive.
	DRIVE PREVENTED - TILTED AND ABOVE ELEVATION Drive is selected while drive cutout is active and drive cutout is configured to prevent drive.
	TILT MODULE FAILURE: NOT COMMUNICATING There is a problem with the positrac/tilt module; the controller defaults to massively tilted and does not try to prevent vehicle roll on the grade.
	3/1
LINE & DIRECTION CONTACTORS MISWIRED When the line contactor was closed traction point A went high (and the capacitor bank charge did not increase to battery supply) - this occurs if the line contactor coil wiring is swapped with that for a direction contactor coil.	
OPEN-CIRCUIT FORWARD DIRECTION CONTACTOR OR TRACTION MOTOR Traction point A did not go high when forward contactor was energized (this could be due to traction motor open-circuit or a power wiring error).	
OPEN-CIRCUIT LINE CONTACTOR OR TRACTION MOTOR The capacitor bank charge did not increase to battery supply when line contactor was energized (this could be due to a power wiring error).	
OPEN-CIRCUIT REVERSE DIRECTION CONTACTOR Traction point A did not go high when reverse contactor was energized (this could be due to traction motor open-circuit or a power wiring error).	
3/2	Flash code 3/2 indicates that a contactor did not open when energized.
	WELDED LINE CONTACTOR The capacitor bank charge did not decrease from battery supply when line contactor was deenergized (this could be due to a power wiring error). WARNING: If the line contactor is welded, the controller will not switch off when EMS or keyswitch is turned off.

Table 6-4. Help Descriptions and Fault Flash Codes

3/3	Flash code 3/3 indicates that a contactor coil is short-circuited.
	OVERLOADED VALVE SUPPLY-CHECK WIRING. There is a high current draw from the valve supply when no valve is energized; this is probably due to a wiring error at the ground module.
	SHORT-CIRCUIT FORWARD CONTACTOR COIL The forward contactor was not energized when required, due to coil overcurrent protection.
	SHORT-CIRCUIT LINE CONTACTOR COIL The line contactor was not energized when required, due to coil overcurrent protection.
	SHORT-CIRCUIT REVERSE CONTACTOR COIL The reverse contactor was not energized when required, due to coil overcurrent protection.
3/5	Flash code 3/5 indicates that there is a brake pressure problem.
	BRAKES DID NOT LOCK Brake pressure did not clear when the brake valve was deenergized.
	BRAKES DID NOT RELEASE No brake pressure was detected when running the pump motor and energizing the brake valve
4/2	Flash code 4/2 indicates that the controller is over temperature.
	CONTROLLER TOO HOT - PLEASE WAIT The controller heatsink temperature reached 75 degrees. The controller is shut down until it cools to below 70 degrees.
4/4	Flash code 4/4 indicates problems with the battery supply.
	BATTERY LOW Battery voltage is below 40V. This is a warning - the controller does not shut down.
	BATTERY TOO HIGH - SYSTEM SHUT DOWN Battery voltage is above 62V. EMS recycle required.
	BATTERY TOO LOW - SYSTEM SHUT DOWN Battery voltage is below 33V. EMS recycle required.
5/5	Flash code 5/5 indicates problems with vehicle speed or the encoder.
	NO VEHICLE MOVEMENT DETECTED AT MAXIMUM POWER No speed was measured with traction motor full on. This could be due to a traction motor fault, a power wiring error, a speed encoder fault, the brakes not releasing (although brake Pressure is OK) or the vehicle being overloaded so that the motor cannot turn the wheels.
	DRIVE PREVENTED - BOTH SPEED ENCODERS FAULTY Both speed encoder input voltages are out of range.
	LEFT SPEED ENCODER FAULTY The left speed encoder input voltages are out of range. The vehicle will continue to drive at cutback using the right speed encoder.
	RIGHT SPEED ENCODER FAULTY The right speed encoder input voltages are out of range. The vehicle will continue to drive at cutback using the left speed encoder.
	SPEED ENCODERS READING INVALID SPEED One or both speed encoders is indicating an impossible number of pulses. This is probably due to a faulty speed encoder.
	VEHICLE RUNAWAY - CHECK SPEED ENCODERS Speed in the wrong direction was measured with traction motor full on. This is probably due to the speed encoder being fitted incorrectly; it could also be due to a speed encoder fault or faults as for "NO VEHICLE MOVEMENT DETECTED" with the vehicle on a grade.

SECTION 6 - JLG CONTROL SYSTEM

Table 6-4. Help Descriptions and Fault Flash Codes

6/6	Flash code 6/6 indicates problems with the CANbus.
	48V PROTECTION TRIPPED - CHECK INTER-MODULE WIRING The power module is not receiving acknowledgments from the platform or ground modules to transmitted data, and the protection circuit which supplies the platform and ground modules has tripped. This is probably due to wiring problems at the platform or ground module.
	CANbus FAILURE: GROUND MODULE The power module is receiving from the platform module but not the ground module. This should not be possible!
	CANbus FAILURE: PLATFORM MODULE The power module is receiving from the ground module but not the platform module. This is probably due to wiring problems between the platform and ground modules.
7/7	CANbus FAILURE: POWER MODULE The power module is not receiving acknowledgments from the platform or ground modules to transmitted data. This is probably due to wiring problems between the ground and power modules.
	Flash code 7/7 indicates problems with a motor.
	CAPACITOR BANK FAULT - CHECK POWER CIRCUITS The capacitor bank is not charging. This is probably due to a power wiring error causing illegal current drain; it could also be due to a very low battery supply.
	OPEN-CIRCUIT PUMP MOTOR Pump point A is collapsing when the pump MOSFETs are pulsed. This is probably due to an open circuit pump motor or a power wiring error.
	OPEN-CIRCUIT DIRECTIONAL CONTACTOR OR TRACTION MOTOR Traction point A is collapsing when the traction MOSFETs are pulsed. This is probably due to an open circuit traction motor or a power wiring error. NOTE: This fault is unlikely to be seen due to interaction with speed control...
	PUMP POINT A LOW - CHECK POWER CIRCUITS Pump point A is near 0V when the pump MOSFETs are off. This is probably due to a power
	STALLED TRACTION MOTOR The power module traction MOSFET protection circuit is active. This is due to massive current drain and could be a stalled traction motor or a power wiring error.
	STALLED PUMP MOTOR The power module pump MOSFET protection circuit is active. This is due to massive current drain and could be a stalled pump motor or a power wiring error.
	TRACTION MOTOR OVERLOADED The traction motor has been operating in current limit at a low percentage on for a period of time greater than 10 seconds.
	PUMP MOTOR OVERLOADED The pump motor has been operating in current limit at a low percentage on for a period of time greater than 10 seconds.
	TRACTION CURRENT AT ZERO - CHECK SHUNT WIRING Traction current measurement is at zero. This is probably due to an open-circuit between the current measurement shunt and the power module.
	TRACTION POINT A HIGH - CHECK POWER CIRCUITS Traction point A is near battery supply when neither direction contactor is energized and the traction MOSFETs are off. This could be due to a welded direction contactor or a power wiring error.
	TRACTION POINT A LOW - CHECK POWER CIRCUITS Traction point A is near 0V when neither direction contactor is energized and the traction MOSFETs are off. This could be due to a power wiring error.

Table 6-4. Help Descriptions and Fault Flash Codes

9/9	Flash code 9/9 indicates problems with the controller.
	POWER MODULE FAILURE: CONTACTOR DRIVE CODE 1 A contactor remained energized when turned off.
	POWER MODULE FAILURE: HWFS CODE 2 The hardware fail-safe tests did not complete because traction point A is not safe, or the hardware fail-safe is permanently tripped.
	POWER MODULE FAILURE: HWFS CODE 3 The hardware fail-safe tests did not complete because a contactor was energized when all should be turned off
	POWER MODULE FAILURE: HWFS CODE 4 The hardware fail-safe tests did not complete because the hardware fail-safe tripped immediately when the traction MOSFETs were turned on.
	POWER MODULE FAILURE: HWFS CODE 10 The hardware fail-safe tests failed because the hardware fail-safe did not trip within the allowed test time.
	POWER MODULE FAILURE: HWFS CODE 11 The hardware fail-safe tests failed because the hardware fail-safe tripped too slowly.
	POWER MODULE FAILURE: HWFS CODE 12 The hardware fail-safe tests failed because the hardware fail-safe tripped too quickly.
	POWER MODULE FAILURE: HWFS CODE 13 The hardware fail-safe tests failed because the hardware fail-safe remained tripped when the traction MOSFETs were turned off.
	POWER MODULE FAILURE: HWFS CODE 14 The hardware fail-safe tests failed because the line contactor could still be energized when the hardware fail-safe was tripped
	POWER MODULE FAILURE: HWFS CODE 15 The hardware fail-safe tests failed because the contactor drive fail-safe did not trip within the allowed test time.
	POWER MODULE FAILURE: HWFS CODE 16 The hardware fail-safe tests failed because the contactor drive fail-safe tripped too slowly.
	POWER MODULE FAILURE: HWFS CODE 17 The hardware fail-safe tests failed because the contactor drive fail-safe tripped too quickly.
	POWER MODULE FAILURE: HWFS TEST STALLED The hardware fail-safe tests did not complete, but no reason can be determined.
	POWER MODULE FAILURE: BAD TEMPERATURE SENSOR The temperature sensor measurement is invalid, this is probably due to a disconnected wire within the power module. The possibility of other disconnected wires (which could cause dangerous system function) means that the controller is shut down.
POWER MODULE FAILURE: S/C LINE CONTACTOR DRIVER The line contactor energized when the foot-switch was closed, before it was turned on, this is probably due to a failed driver within the power module, although it could be due to bad power module wirings	

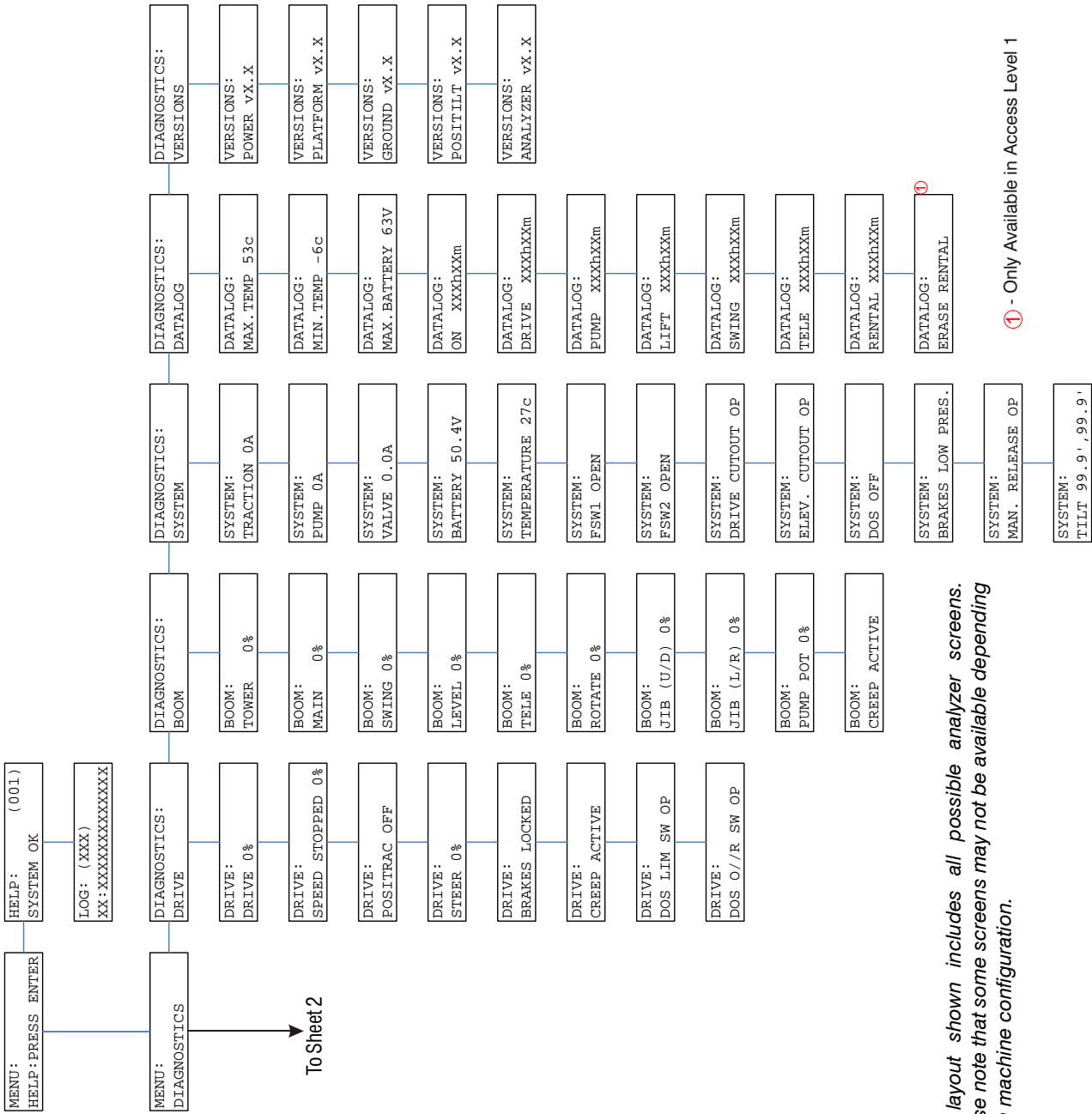

① - Only Available in Access Level 1

NOTE: The layout shown includes all possible analyzer screens. Please note that some screens may not be available depending upon machine configuration.

Figure 6-3. Analyzer Flow Chart (Software Version 3.x) - Sheet 1 of 3

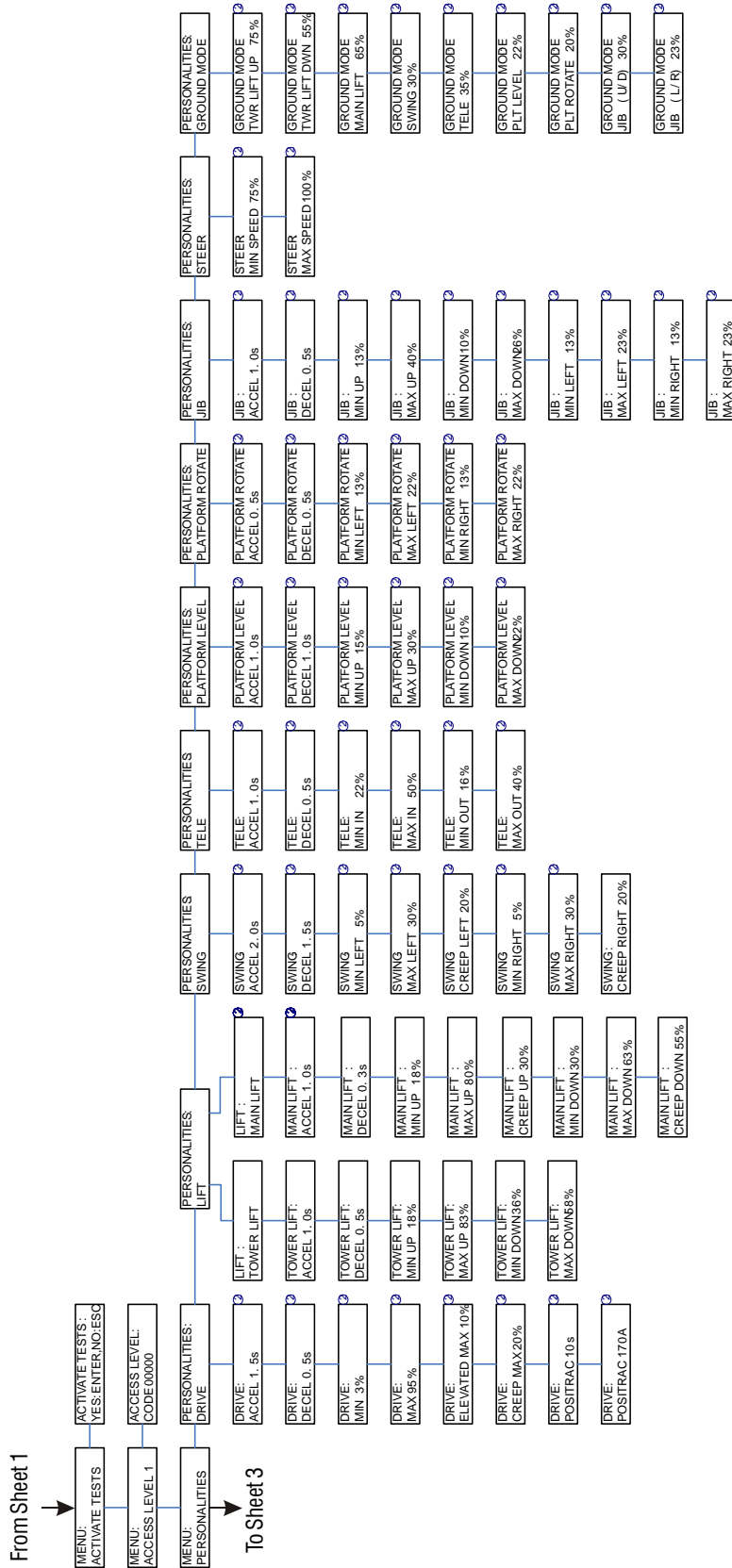

② - Only Available in Access Level 2

NOTE: The layout shown includes all possible analyzer screens. Please note that some screens may not be available depending upon machine configuration.

Figure 6-4. Analyzer Flow Chart (Software Version 3.x) - Sheet 2 of 3

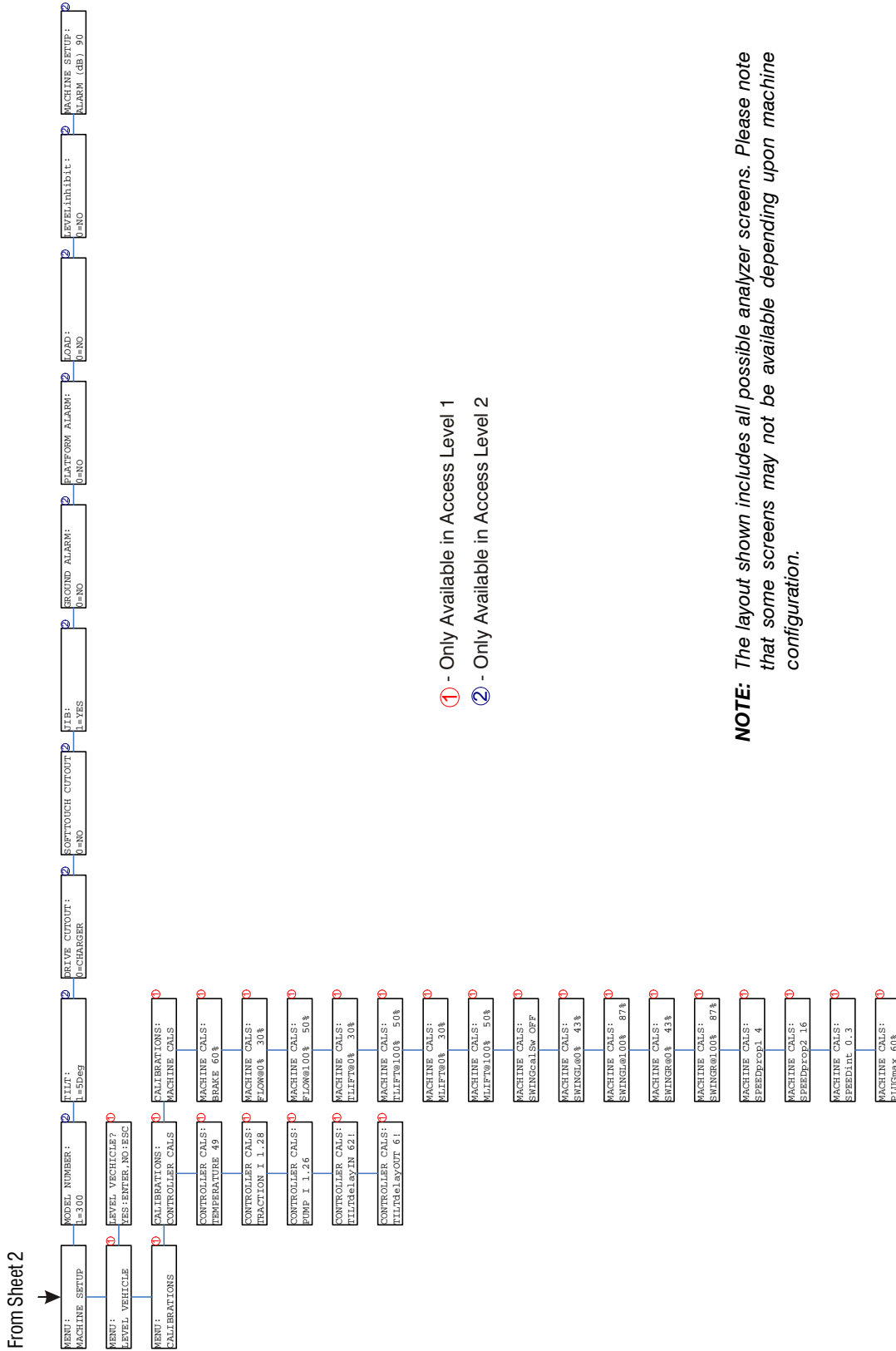

Figure 6-5. Analyzer Flow Chart (Software Version 3.x) - Sheet 3 of 3

Analyzer Diagnostics Menu Structure

In the following structure descriptions, an intended item is selected by pressing ENTER; pressing ESC steps back to

the next outer level. The LEFT/RIGHT arrow keys move between items in the same level. The UP/DOWN arrow keys alter a value if allowed

Table 6-5. DIAGNOSTICS - Menu Descriptions

DRIVE	
DRIVE...	Displays drive joystick direction & demand
SPEED...	Displays vehicle direction & speed
POSITRAC...	Displays positrac status
STEER...	Displays steer switch direction & demand NOTE: steer demand is inversely proportional to vehicle speed
BRAKES...	Displays brake control system status
CREEP..	Displays pump pot creep switch status
BOOM	
LL....	Displays lower lift switch direction & demand NOTE: demand is controlled by the pump pot
UL..	Displays upper lift joystick direction & demand
SWING...	Displays swing joystick direction & demand
LEVEL..	Displays basket level switch direction & demand NOTE: demand is controlled by the pump pot
TELE...	Displays telescope switch direction & demand NOTE: demand is controlled by the pump pot
ROTATE..	Displays basket rotate switch direction & demand NOTE: demand is controlled by the pump pot
JIB (U/D).	Displays jib lift switch direction & demand NOTE: demand is controlled by the pump pot Not displayed if JIB = NO
JIB (L/R)	Displays jib swing switch direction & demand NOTE: demand is controlled by the pump pot Not displayed if JIB = NO
PUMP POT...	Displays pump pot demand
CREEP..	Displays pump pot creep switch status
SYSTEM	
TRACTION...	Displays measured traction motor current
PUMP..	Displays measured pump motor current
VALVE...	Displays measured valve (12V supply) current NOTE: this includes current for the ground alarm & remoter, but not for any lamps
BATTERY...	Displays measured battery voltage
TEMPERATURE...	Displays measured heat sink temperature
FSW1...	Displays footswitch status
FSW2...	Displays footswitch status NOTE: FSW2 is wired to the platform module
DRIVE CUTOUT...	Displays drive cutout switch status
ELEV. CUTOUT...	Displays elevation cutout switch status
FUNC. CUTOUT...	Displays function cutout switch status
BRAKES...	Displays brake pressure switch status
MAN.RELEASE...	Displays manual brake release switch status

Table 6-5. DIAGNOSTICS - Menu Descriptions

TILT...	Displays measured vehicle tilt The first value indicates tilt in die forwards reverse direction (pitch) The second value indicates tilt in the left/ right direction (roll)
DATALOG	
MAX.TEMP..	Displays maximum measured heat sink temp.
MIN.TEMP..	Displays minimum measured heat sink temp.
MAX. BATTERY..	Displays maximum measured battery voltage
ON...	Displays total controller on (EMS) time
DRIVE...	Displays total controller drive operation time
PUMP..	Displays total controller pump running time NOTE: includes all boom functions, steer and brake release
LIFT..	Displays total controller lift operation time
SWING...	Displays total controller swing operation time
TELE...	Displays total controller tell operation time
RENTAL...	Displays total controller operation time NOTE: can be reset
ERASE RENTAL YES:ENTER, NO:ESC ENTER	Not available at password level 2 Enter resets rental datalog time to zero
VERSIONS	
POWER	Displays power software version
PLATFORM	Displays platform software version
GROUND	Displays ground software version
POSITILT	Displays postulate software version
ANALYZER	Displays analyzer software version

System Self Test

The system self test is utilized to locate typical problems. See Table 6-6, System Test Descriptions and Table 6-7, System Test Messages for information concerning the tests performed and available messages in this mode.

1. When the keys witch is in the platform position and the self test enabled, the self test function will test all valves, contactors, platform inputs, indicator lamps, and system alarms for various fault conditions.

When the keys witch is in the ground position, the self test function will test all valves, the line contactor, ground control inputs, and the ground alarm output for various fault conditions.

2. In order to test the inputs on the machine, the controller will ask the service technician to perform various tasks at the appropriate operator control station. An example of this is "Close LLU Switch". The controller expects the operator to close the lower lift up switch. When the controller sees that the lower lift up switch has been closed, it will move on to the next input, lower lift down LLD. If the switch is faulty or the wiring is faulty, the controller will not move on to the

next input. The controller will continue to wait for the closure of the input. If the operator knows the switch is faulty and wants to continue the tests he must simply press the enter key on the analyzer to continue.

3. After the controller has conducted the tests from the chosen operator station, it will display "TESTS COMPLETE". This indicates that the controller has checked all inputs and outputs for that station.

NOTICE

IN ORDER FOR THE MACHINE TO FUNCTION AFTER THE SELF TEST IS COMPLETE, POWER MUST BE RECYCLED USING THE EMS OR THE KEY SWITCH.

Table 6-6. System Test Descriptions

<p>ACTIVATE TESTS YES:ENTER, NO:ESC</p>	<p>Not available once tests are activated ENTER activates system tests NOTE: cannot be done while controller is in use (footswitch closed) and for a short time afterwards</p>
<p>RUN SYSTEM TEST</p>	<p>ENTER starts system test Not available until tests are activated Displays messages while system test runs Some messages are prompts, requiring user intervention. ENTER can be pressed if a fault is found, to confirm that the fault has been noted and to continue the system test. NOTE: a flashing message is critical, and prevents the system test running</p>

Table 6-7. System Test Messages

<p>RUNNING</p>	<p>Initial display when system test is run; certain "critical" checks are made. Problems which can be reported include:</p> <p>ONLY 1 ANALYZER! Do not connect two Analyzers while running the system test.</p> <p>BAD POWER WIRING The capacitor bank is not charged or pump point A is low or traction point A is high or low. Check all power wiring.</p> <p>LINE CONT WELDED The capacitor bank is at battery voltage. Check line contactor. Check all power wiring.</p> <p>BATTERY TOO LOW The system test cannot run with battery voltage below minimum.</p> <p>BATTERY TOO HIGH The system test cannot run with battery voltage above maximum.</p> <p>CHECK CAN WIRING The system test cannot run in platform mode unless data is being received from the platform, ground and positrac/tilt modules. The system test cannot run in ground mode unless data is being received from the ground and positrac/tilt modules.</p> <p>CHECK LEFT SPD. There is an open- or short- circuit in the left speed encoder wiring. Check left speed encoder.</p> <p>CHECK RIGHT SPD. There is an open- or short- circuit in the right speed encoder wiring. Check right speed encoder.</p> <p>CHECK SHUNT The traction current measurement is open-circuit. Check wiring between power module and contactor panel.</p> <p>BAD PUMP WIRING Pump point A is not high, probably caused by an open-circuit pump motor or wiring. Check all power wiring. Check pump motor.</p> <p>BAD POWER MODULE An internal problem was detected in the power module.</p> <p>BAD POWER WIRING Traction point A is high, probably caused by incorrect traction motor wiring. Check all power wiring. Check traction motor.</p> <p>HIGH TILT ANGLE The vehicle is very tilted, or the tilt sensor has been damaged. Check tilt sensor.</p> <p>HOT POWER MODULE The heat sink temperature exceeds 75°C; this is only a warning.</p> <p>BAD I/O PORTS The controller detected a problem with its internal circuits at switch on. If other problems are also detected, the controller may need replacing.</p> <p>SUSPECT EEPROM The controller detected a problem with its EEPROM stored personality settings at switch on. Check and, if necessary correct, all personality settings.</p> <p>WAIT:CAPBANK HI This message can be displayed if the system test is run shortly after the vehicle was used; after a short wait, it should clear.</p> <p>OPEN FWS In platform mode, the foot switch must be open at the start of the test.</p> <p>CLOSE FWS In platform mode, the foot switch must be closed when this message is displayed; the foot switch MUST BE KEPT CLOSED during the valve & contactor tests.</p> <p>BAD FWS The two foot switch signals are not changing together, probably because one is open-circuit. One foot switch signal ("FSW1") is routed to the power module, the other ("FSW2") is routed to the platform module. Check foot switch and wiring.</p>
----------------	---

Table 6-7. System Test Messages

TESTING VALVES	<p>Indicates that the valve test is beginning. Each valve is alternately energized and de-energized; checks are made for open-and short-circuit valve coils. The valves are tested in the order: PROP (main proportional), LL U, LL D, UL U, UL D, SWING L, SWING R, SWING REST, LEVEL U, LEVEL D, ROTATE L, ROTATE R, JIB U, JIB D, TELE I, TELE O, BYPASS, STEER L, STEER R, STEER PROP, BRAKE NOTE: in platform mode, the foot switch must be closed. NOTE: jib valves are not tested if JIB = NO Problems which can be reported include: CANT TEST VALVES There is a wiring problem which prevents the valve test from functioning correctly. Check valve wiring. Check ground alarm wiring. valve name S/C The named valve is drawing too much current so is presumed to be short-circuit. Check valve wiring. valve name O/C The named valve is drawing too little current so is presumed to be open-circuit. Check valve wiring.</p>
VALVE TEST DONE	<p>Indicates that the valve test is complete (with or without faults).</p>
TESTING CONTS	<p>Indicates that the contactor test is beginning. In platform mode, the forward & reverse direction contactors are energized and de-energized; checks are made that they close & open correctly and for short-circuit coils. In platform and ground mode, the line contactor is energized and de-energized; checks are made that it closed & opened correctly and for a short-circuit coil. In platform mode, the positrac contactors are energized and de-energized; checks are made for short-circuit and open-circuit coils. Problems which can be reported include: CANT TEST CONTS There is a wiring problem which prevents the contactor test from functioning correctly. Check power wiring. Check contactor wiring. BAD CONT WIRING There is a wiring problem which caused the capacitor bank to be charged when a direction contactor was energized; probably the wiring to the contactor coils is incorrect. Check contactor wiring. Check power wiring. cont name WELDED The named contactor appears to have not opened. Check named contactor. Check power wiring. cont name COIL S/C The named contactor coil overloaded its driver circuit so is presumed to be short-circuit. Check contactor wiring. cont name DIDN'T CLOSE The named contactor appears to have not closed. Check contactor wiring. Check power wiring.</p>
CONT TEST DONE	<p>Indicates that the contactor test is complete (with or without faults).</p>

SECTION 6 - JLG CONTROL SYSTEM

Table 6-7. System Test Messages

CHECKING INPUTS	<p>Indicates that the inputs test is beginning. Every input is checked to ensure that it is in its "normal" position; function switches should be open, cutout switches should be closed, joysticks should be in neutral.</p> <p>In platform mode, inputs are tested in the order: UL U, UL D, UL JOY., SWING L, SWING R, SWING JOY., LEVEL U, LEVEL D, PUMP POT., ROTATE L, ROTATE R, LL U, LL D, JIB U, JIB D, TELE I, TELE O, DRIVE FWD, DRIVE REV, DRIVE JOY., STEER L, STEER R, POSITRAC, DRIVE C/O, ELEV. C/O, FUNC. C/O, BRAKE PRES</p> <p>In ground mode, inputs are tested in the order: ROTATE L, ROTATE R, LEVEL U, LEVEL D, JIB U, JIB D, TELE I, TELE O, UL U, UL D, LL U, LL D, SWING L, SWING R, ELEV. C/O, FUNC. C/O, BRAKE PRES, MAN. BRAKE</p> <p>NOTE: switches which are not in use (due to the settings of machine digits) are not checked. NOTE: the pump pot is checked only for a wire-off condition; it can be at any demand from creep to maximum.</p> <p>Problems which can be reported include:</p> <ul style="list-style-type: none"> CHECK switch name <ul style="list-style-type: none"> The named switch is not in its "normal" position. Check switch & wiring. CHECK switchman JOY. <ul style="list-style-type: none"> The named joystick appears to be faulty. Check joystick.
INPUTS DONE	<p>Indicates that the inputs test is complete (with or without faults).</p>
TESTING LAMPS	<p>Indicates that the lamps test is beginning. Each lamp is energized in turn; a prompt asks for confirmation that the lamp is lit - ENTER must be pressed to continue the test.</p> <p>Lamps are tested in the order: ENABLE, FAULT, TILT, CREEP, POSITRAC, WATER.</p> <p>NOTE: lamps which are not in use (due to the settings of machine digits) are not checked.</p> <p>NOTE: lamps are only tested in platform mode.</p> <p>Problems which can be reported include:</p> <ul style="list-style-type: none"> lamp name S/C <ul style="list-style-type: none"> A short-circuit condition appeared while the named lamp was being tested, presumably because it is short-circuit.
LAMP TEST DONE	<p>Indicates that the lamps test is complete.</p>
TESTING ALARMS	<p>Indicates that the alarms test is beginning. Each alarm is energized in turn; a prompt asks for confirmation that the alarm is sounding - ENTER must be pressed to continue the test.</p> <p>Alarms are tested in the order: P.ALARM, G.ALARM.</p> <p>NOTE: the platform alarm is only tested in platform mode.</p> <p>NOTE: the ground alarm is not tested if GROUND ALARM = NO.</p> <p>Problems which can be reported include:</p> <ul style="list-style-type: none"> alarm name S/C <ul style="list-style-type: none"> A short-circuit condition appeared while the named alarm was being tested, presumably because it is short-circuit.
ALARM TEST DONE	<p>Indicates that the alarms test is complete.</p>

Table 6-7. System Test Messages

<p>TEST ALL INPUTS?</p>	<p>Prompts whether to check every operator input. If ESC is pressed, the system test ends. If ENTER is pressed, each operator input is prompted for in turn. In platform mode, operator inputs are tested in the order: UL U, UL D, SWING L, SWING R, LEVEL U, LEVEL D, PUMP POT, CREEP, ROTATE L, ROTATE R, LL U, LL D, JIB U, JIB D, TELE I, TELE O, DRIVE FWD, DRIVE REV, STEER L, STEER R, POSITRAC In ground mode, operator inputs are tested in the order: ROTATE L, ROTATE R, LEVEL U, LEVEL D, JIB U, JIB D, TELE I, TELE O, UL U, JIB D, LL U, LL D, SWING L, SWING R NOTE: the jib switches are not tested if JIB = NO. Prompts displayed during the operator input test include: CLOSE switch name The named switch should be closed. OPEN switch name The named switch should be opened. joystick name direction TO MAX The named joystick should be pushed to its full extent in the named direction. joystick name direction TO MIN The named joystick should be returned to neutral from the named direction. PUMP POT TO MAX The pump pot should be turned to maximum. PUMP POT TO MIN The pump pot should be turned to minimum. MULTIPLE CLOSURE More than one operator input is closed; if only one has been operated, there could be a short between two inputs.</p>
<p>TESTS COMPLETE</p>	<p>Indicates that the system test is complete. Any problems reported should have been noted and should now be rectified. Press ESC to return to the RUN SYSTEM TEST Analyzer menu.</p>

SECTION 6 - JLG CONTROL SYSTEM

Table 6-8. Diagnostic Fault Codes

DTC	Flash Code	Fault Message	Description
001	00	EVERYTHING OK	The "normal" help message in platform mode
002	00	GROUND MODE OK	The "normal" help message in ground mode
0010	00	RUNNING AT CUTBACK - OUT OF TRANSPORT POSITION	Drive speed is limited to "ELEVATED MAX" while the vehicle is out of transport position.
0011	00	FSW OPEN	A drive or boom function has been selected but footswitch is open.
0012	00	RUNNING AT CREEP - CREEP SWITCH OPEN	All function speeds are limited to creep because the creep switch is open.
0013	00	RUNNING AT CREEP - TILTED AND ABOVE ELEVATION	All function speeds are limited to creep because the vehicle is tilted and above elevation.
0032	00	PUMP MOTOR AT CURRENT LIMIT	Pump current has reached controller current limit or safe operating area limit.
0033	00	TRACTION MOTOR AT CURRENT LIMIT	Traction current has reached controller current limit or safe operating area limit.
0034	00	DRIVING AT CREEP - TILTED	Drive speed is limited to creep because the vehicle is tilted.
211	21	POWER CYCLE	The normal help message is issued at each power cycle.
212	21	KEYSWITCH FAULTY	Both Platform and Ground modes are selected simultaneously.
213	21	FSW FAULTY	Both Footswitch Inputs are closed for more then one second.
221	22	FUNCTION PROBLEM - HORN PERMANENTLY SELECTED	Input was CLOSED during startup
224	22	FUNCTION PROBLEM - STEER LEFT PERMANENTLY SELECTED	The Steer Left Switch was closed during power-up.
225	22	FUNCTION PROBLEM - STEER RIGHT PERMANENTLY SELECTED	The Steer Right Switch was closed during power-up.
227	22	STEER SWITCHES FAULTY	Both Steer Left and Steer Right inputs are closed simultaneously.
2211	22	FSW INTERLOCK TRIPPED	The Footswitch was closed for more then seven seconds.
2212	22	DRIVE LOCKED - JOYSTICK MOVED BEFORE FOOTSWITCH	A drive function was selected with Footswitch open.
2213	22	STEER LOCKED - SELECTED BEFORE FOOTSWITCH	A steer function was selected with Footswitch open.
2221	22	LIFT/SWING LOCKED - JOYSTICK MOVED BEFORE FOOTSWITCH	A lift / swing function was selected with Footswitch open.
2222	22	WAITING FOR FSW TO BE OPEN	The Footswitch was closed during Platform selection.
2245	22	FUNCTION PROBLEM - JIB SWING LEFT PERMANENTLY SELECTED	Input was CLOSED during startup
2246	22	FUNCTION PROBLEM - JIB SWING RIGHT PERMANENTLY SELECTED	Input was CLOSED during startup
2247	22	FUNCTION PROBLEM - PLATFORM ROTATE LEFT PERMANENTLY SELECTED	Input was CLOSED during startup
2248	22	FUNCTION PROBLEM - PLATFORM ROTATE RIGHT PERMANENTLY SELECTED	Input was CLOSED during startup
2249	22	FUNCTION PROBLEM - JIB LIFT UP PERMANENTLY SELECTED	Input was CLOSED during startup
2250	22	FUNCTION PROBLEM - JIB LIFT DOWN PERMANENTLY SELECTED	Input was CLOSED during startup
2251	22	FUNCTION PROBLEM - TELESCOPE IN PERMANENTLY SELECTED	Input was CLOSED during startup

Table 6-8. Diagnostic Fault Codes

DTC	Flash Code	Fault Message	Description
2252	22	FUNCTION PROBLEM - TELESCOPE OUT PERMANENTLY SELECTED	Input was CLOSED during startup
2253	22	FUNCTION PROBLEM - SWING LEFT PERMANENTLY SELECTED	Input was CLOSED during startup
2254	22	FUNCTION PROBLEM - SWING RIGHT PERMANENTLY SELECTED	Input was CLOSED during startup
2255	22	FUNCTION PROBLEM - MAIN LIFT UP PERMANENTLY SELECTED	Input was CLOSED during startup
2256	22	FUNCTION PROBLEM - MAIN LIFT DOWN PERMANENTLY SELECTED	Input was CLOSED during startup
2257	22	FUNCTION PROBLEM - TOWER LIFT UP PERMANENTLY SELECTED	Input was CLOSED during startup
2258	22	FUNCTION PROBLEM - TOWER LIFT DOWN PERMANENTLY SELECTED	Input was CLOSED during startup
2259	22	FUNCTION PROBLEM - DRIVE FORWARD PERMANENTLY SELECTED	Input was CLOSED during startup
2260	22	FUNCTION PROBLEM - DRIVE REVERSE PERMANENTLY SELECTED	Input was CLOSED during startup
2261	22	FUNCTION PROBLEM - MULTIPLE SWITCHES PERMANENTLY SELECTED	Input was CLOSED during startup
2262	22	FUNCTION PROBLEM - PLATFORM LEVEL UP PERMANENTLY SELECTED	Input was CLOSED during startup
2263	22	FUNCTION PROBLEM - PLATFORM LEVEL DOWN PERMANENTLY SELECTED	Input was CLOSED during startup
2264	22	FUNCTION PROBLEM - DOS DOWN PERMANENTLY SELECTED	Input was CLOSED during startup
2265	22	FUNCTION PROBLEM - POSI DOWN PERMANENTLY SELECTED	Input was CLOSED during startup
2266	22	LIFT/SWING JOYSTICK FAULTY	Joystick was out of the Neutral position during startup
2267	22	DRIVE/STEER JOYSTICK FAULTY	Joystick was out of the Neutral position during startup
2268	22	JOYSTICKS FAULTY	Both Joysticks are faulty, or one joystick is faulting the 5 volt supply to both joysticks.
2376	23	SWING SWITCH FAULTY	Both states actively HIGH in Ground Mode
2387	23	JIB LIFT SWITCH FAULTY	Both states actively HIGH
2388	23	JIB SWING SWITCH FAULTY	Both states actively HIGH
2389	23	PLATFORM ROTATE SWITCH FAULTY	Both states actively HIGH
2390	23	TELESCOPE SWITCH FAULTY	Both states actively HIGH
2391	23	MAIN LIFT SWITCH FAULTY	Both states actively HIGH
2392	23	TOWER LIFT SWITCH FAULTY	Both states actively HIGH
2393	23	PLATFORM LEVEL SWITCH FAULTY	Both states actively HIGH
2394	23	PUMP POT FAULTY	Creep pot is OPEN circuit
2395	23	FUNCTION SWITCHES FAULTY	Function switch has both direction selected at the same time
253	25	DRIVE PREVENTED - CHARGER CONNECTED	Driving is not possible while the vehicle is charging
254	25	DRIVE & LIFT UP PREVENTED - CHARGER CONNECTED	Drive or Lift is not possible while the vehicle is charging AND is configured to prevent all motion.
2510	25	DRIVE PREVENTED - BRAKES NOT RELEASING	No Brake pressure was detected when running the pump motor and energizing the brake valve

SECTION 6 - JLG CONTROL SYSTEM

Table 6-8. Diagnostic Fault Codes

DTC	Flash Code	Fault Message	Description
2514	25	BOOM PREVENTED - DRIVE SELECTED	Boom functions are not possible while the vehicle is being driven AND is configured to not allow simultaneous drive & boom operation.
2516	25	DRIVE PREVENTED - ABOVE ELEVATION	Driving is not possible while Boom functions are selected AND is configured to not allow simultaneous drive & boom operation.
2517	25	DRIVE PREVENTED - TILTED & ABOVE ELEVATION	Driving is not possible while the vehicle is tilted and above elevation AND is configured to prevent drive while tilted and above elevation.
2518	25	DRIVE PREVENTED - BOOM SELECTED	Driving is not possible while the vehicle boom functions are selected AND is configured to not allow simultaneous drive & boom operation.
2536	25	ALL FUNCTIONS PREVENTED - FUNCTION CUTOFF	Machine Setup's set for "1 = CHARGER & BOOM" and machine is above elevation
2542	25	FUNCTION PREVENTED - BRAKES ELECTRONICALLY RELEASED FOR TOWING	Indicates Manual Brake release active in Ground mode
2548	25	SYSTEM TEST MODE ACTIVE	System test mode active
2549	25	DRIVE & BOOM PREVENTED - SOFT TOUCH ACTIVE	Machine Setup's SOFT TOUCH is set for "2 = BOOM & DRIVE" and Soft touch switch is OPEN
2550	25	BOOM PREVENTED - FUNCTION CUTOFF ACTIVE	Machine Setup's DRIVE CUTOFF is set for "1 = CHARGER & BOOM" and machine is above elevation
2551	25	TELESCOPE OUT PREVENTED - TILTED & ABOVE ELEVATION	Telescope OUT is not possible while the vehicle is tilted and above elevation AND is configured to prevent drive while tilted and above elevation.
2552	25	LIFT UP PREVENTED - TILTED & ABOVE ELEVATION	Lift UP is not possible while the vehicle is tilted and above elevation AND is configured to prevent drive while tilted and above elevation.
2553	25	LEVELING PREVENTED - ABOVE ELEVATION	Machine Setup's LEVEL inhibit is set for "1 = ELEV" and machine is above elevation
2554	25	DRIVE PREVENTED - SPEED SENSORS FAULTY	Both Speed sensor input voltages are out of range
2555	25	FUNCTION PREVENTED - SELECTED BEFORE FSW	Function switch was selected before and during foot switch closure
2556	25	FUNCTION PREVENTED - SELECTED BEFORE EMS	Function was CLOSED at power up
321	32	LINE CONTACTOR WELDED OR MISWIRED	The capacitor bank charge did not decrease from battery supply when line contactor was de-energized (this could be caused due to a power wiring error)
325	32	LINE & DIRECTION CONTACTORS MISWIRED	When the line contactor was closed, traction point A went HIGH (and the capacitor bank charge did not increase to battery supply) - this occurs if the line contactor coil wiring is swapped with that for a direction contactor coil
33300	33	LINE CONTACTOR COIL - OPEN CIRCUIT	The capacitor bank did not increase to battery supply when the line contactor was CLOSED
33301	33	LINE CONTACTOR COIL - SHORT TO GROUND	Line contactor was not energized when required, due to over current protection
33361	33	DIRECTION CONTACTOR COIL - OPEN CIRCUIT	Traction point A is collapsing when the traction MOSFETs are pulsed. This maybe due to an open circuit traction motor or power wiring error

Table 6-8. Diagnostic Fault Codes

DTC	Flash Code	Fault Message	Description
33364	33	FORWARD CONTACTOR COIL - OPEN CIRCUIT	Traction point A did not go HIGH when forward contactor was energized. This maybe due to an open circuit traction motor or power wiring error
33369	33	REVERSE CONTACTOR COIL - OPEN CIRCUIT	Traction point A did not go HIGH when reverse contactor was energized. This maybe due to an open circuit traction motor or power wiring error
33370	33	FORWARD CONTACTOR COIL - SHORT CIRCUIT	The forward contactor was not energized when required, due to over current protection
33371	33	REVERSE CONTACTOR COIL - SHORT CIRCUIT	The reverse contactor was not energized when required, due to over current protection
33411	33	VALVE SUPPLY OVERLOADED	There is a high current draw from the valve supply when no valve is energized; this maybe due to a wiring error at the ground module
421	42	POWER MODULE TOO HOT - PLEASE WAIT	Controller heat sink temperature reached 75°C, the controller is shut down until it cools to below 70°C
441	44	BATTERY VOLTAGE TOO LOW - SYSTEM SHUTDOWN	Battery voltage is below 33 volts EMS recycle is required
442	44	BATTERY VOLTAGE TOO HIGH - SYSTEM SHUTDOWN	Battery voltage is above 62 volts, EMS recycle is required
445	44	BATTERY VOLTAGE LOW	Battery voltage is below 40 volts, this is only a warning, the controller does not shut down
469	46	VEHICLE OVERSPEED	Speed in the wrong direction was measured with the traction motor full ON. This maybe due to a faulty speed sensor being installed incorrectly; it could also be due to a speed sensor fault or faults for NO VEHICLE MOVEMENT DETECTED with the vehicle on a grade
4610	46	RIGHT SPEED SENSOR - NOT RESPONDING PROPERLY	The right speed sensor is indicating an impossible number of pulses, this maybe due to a faulty speed sensor
4611	46	LEFT SPEED SENSOR - NOT RESPONDING PROPERLY	The left speed sensor is indicating an impossible number of pulses, this maybe due to a faulty speed sensor
4615	46	SPEED SENSOR - INVALID READING	Both speed sensors are indicating impossible number of pulses, this maybe due to a faulty speed sensor
4616	46	BRAKES DID NOT LOCK	Brake pressure did not clear when the brake valve was de-energized
4617	46	NO VEHICLE MOVEMENT DETECTED AT MAXIMUM POWER	No speed was measured with the traction motor full ON. This could be due to a traction motor fault, a power wiring error, a speed sensor fault, the brakes not releasing (though brake pressure is OK) or the vehicle being overloaded so that the motor cannot turn the wheels
661	66	CANBUS FAILURE - POWER MODULE	Power Module CAN communication lost.
662	66	CAN BUS FAILURE - PLATFORM MODULE	Platform Module CAN communication lost.
6631	66	CAN BUS FAILURE - GROUND MODULE	Ground Module CAN communication lost.
6636	66	CANBUS FAILURE - TILT MODULE	Tilt Module CAN communication lost.
772	77	STALLED TRACTION MOTOR OR POWER WIRING ERROR	The power module traction MOSFET protection circuit is active, This is due to a massive current drain and could be a stalled traction motor or a power wiring error
773	77	CAPACITOR BANK FAULT - CHECK POWER CIRCUITS	The capacitor bank is not charging, this maybe due to a power wiring error causing illegal current drain or a very low battery voltage

SECTION 6 - JLG CONTROL SYSTEM

Table 6-8. Diagnostic Fault Codes

DTC	Flash Code	Fault Message	Description
776	77	STALLED PUMP MOTOR OR POWER WIRING ERROR	The power module pump MOSFET protection circuit is active, This is due to a massive current drain and could be a stalled pump motor or a power wiring error
777	77	OPEN CIRCUIT PUMP MOTOR WIRING	Pump point A is collapsing when the pump MOSFETs are pulsed, this maybe due to an OPEN circuit pump motor or a power wiring error
7734	77	TRACTION A HIGH - CHECK POWER CIRCUITS	Traction point A is near battery supply when neither direction contactor is energized and the traction MOSFETs are OFF, this maybe due to a welded direction contactor or a power wiring error
7735	77	TRACTION A LOW - CHECK POWER CIRCUITS	Traction point A is near ZERO volts when neither direction contactor is energized and the traction MOSFETs are OFF, this maybe due to a power wiring error
7736	77	TRACTION MOTOR OVERLOADED	The traction motor has been operating in current limit at a low percentage on for a long time greater than 10 seconds
7737	77	PUMP MOTOR OVERLOADED	The pump motor has been operating in current limit at a low percentage on for a long time greater than 10 seconds
7738	77	PUMP A LOW - CHECK POWER CIRCUITS	Pump point A is near ZERO volts when the pump MOSFETs are OFF, this maybe due to a power wiring error
7739	77	B+ AND A CROSSED - CHECK POWER CIRCUITS	startup test detected B+ is connected to point A and point A is connected to B+
7740	77	TRACTION CURRENT AT ZERO - CHECK SHUNT WIRING	Traction current is at ZERO, this maybe due to an open circuit between the current measurement shunt and the power module
826	82	RUNNING AT CREEP - PLATFORM OVERLOADED	All functions at creep, the Load Sensing System indicates the Platform is overloaded AND is configured to warn only while the Platform is overloaded.
827	82	DRIVE & BOOM PREVENTED - PLATFORM OVERLOADED	Driving and boom functions are not possible while the Load Sensing System indicates the Platform is overloaded AND is configured to prevent drive and boom functions while the Platform is overloaded.
99125	99	POWER MODULE FAILURE - HWFS CODE 2	Hardware failsafe tests did not complete because traction point A is not safe, or the hardware failsafe is permanently tripped
99126	99	POWER MODULE FAILURE - HWFS CODE 3	Hardware failsafe tests did not complete because a contactor was energized when all should be turned off
99127	99	POWER MODULE FAILURE - HWFS CODE 4	Hardware failsafe tests did not complete because the hardware failsafe tripped immediately when the traction MOSFETs were turned ON
99128	99	POWER MODULE FAILURE - HWFS CODE 10	Hardware failsafe tests failed because the hardware failsafe did not trip within the allowed test time
99129	99	POWER MODULE FAILURE - HWFS CODE 11	Hardware failsafe tests failed because the hardware failsafe tripped too slowly
99130	99	POWER MODULE FAILURE - HWFS CODE 12	Hardware failsafe tests failed because the hardware failsafe tripped too Quickly
99131	99	POWER MODULE FAILURE - HWFS CODE 13	Hardware failsafe tests failed because the hardware failsafe remained tripped when the traction MOSFETs were turned OFF
99132	99	POWER MODULE FAILURE - HWFS CODE 14	Hardware failsafe tests failed because the hardware failsafe the line contactor could not be energized when the hardware failsafe was tripped

Table 6-8. Diagnostic Fault Codes

DTC	Flash Code	Fault Message	Description
99133	99	POWER MODULE FAILURE - HWFS CODE 15	Hardware failsafe tests failed because the hardware failsafe the contactor drive failsafe did not trip within the allowed test time
99134	99	POWER MODULE FAILURE - HWFS CODE 16	Hardware failsafe tests failed because the hardware failsafe the contactor drive failsafe tripped too slowly
99135	99	POWER MODULE FAILURE - HWFS CODE 17	Hardware failsafe tests failed because the hardware failsafe the drive contactor failsafe tripped too quickly
99136	99	POWER MODULE FAILURE - HWFS TEST STALLED	Hardware failsafe tests did not complete, but no reason can be determined
99137	99	POWER MODULE FAILURE - LINE CONTACTOR DRIVER	The line contactor energized when the footswitch was CLOSED before it was ON, this maybe due to a failed driver within the power module, or a power wiring error
99138	99	POWER MODULE FAILURE - TEMPERATURE SENSOR	The temperature sensor measurement is invalid, this maybe due to a disconnected wire within the power module.
99139	99	POWER MODULE FAILURE - CONTACTOR CODE 1	A contactor remained energized when turned OFF
99140	99	TILT MODULE FAILURE - INTERNAL ERROR	Startup test detected faulty tilt sensors, or voltages on the tilt sensor are bad (could be caused if positilt is mounted upside down or vertical
99141	99	GROUND MODULE - OBSOLETE ON THIS VEHICLE	The power module determined the hardware version of the Ground module was incompatible with the current software
99142	99	48V PROTECTION TRIPPED	The power module is not receiving acknowledgements from the platform module or ground module to transmitted data, and the protection circuit which supplies the platform and ground modules has tripped. This maybe due to wiring problems at the platform or groundmodule.

SECTION 7. BASIC TROUBLESHOOTING, ELECTRICAL INFORMATION, & SCHEMATICS

7.1 GENERAL

This section contains basic troubleshooting information and basic electrical information to be used for locating and correcting most of the operating problems which may develop. If a problem should develop which is not presented in this section or which is not corrected by listed corrective actions, technically qualified guidance should be obtained before proceeding with any maintenance.

7.2 TROUBLESHOOTING

The troubleshooting procedures applicable to the aerial platform are listed and defined in Table 7-1 through Table 7-6. As an aid to table use, the aerial platform is divided into four major groups, each covered separately within this section. These groups are as follows: elevation system, chassis assembly, hydraulic system and electrical system.

Each malfunction within an individual group or system is followed by a listing of probable causes which will enable determination of the applicable remedial action. The probable causes and the remedial action should, where possible, be checked in the order listed in the tables.

It should be noted that there is no substitute for a thorough knowledge of the equipment and related systems.

It should be recognized that the majority of the problems arising in the machine will be centered in the hydraulic and electrical systems. For this reason, every effort has been made to ensure that all likely problems in these areas are given the fullest possible treatment. In the remaining machine groups, only those problems which are symptomatic of greater problems which have more than one probable cause and remedy are included. This means that problems for which the probable cause and remedy may be immediately obvious are not listed in this section.

The first rule for troubleshooting any circuit that is hydraulically operated and electrically controlled is to determine if the circuit is lacking hydraulic oil and electrical control power. This can be ascertained by overriding the bypass valve so that oil is available to the function valve, then overriding the function valve mechanically. If the function performs satisfactorily, the problem exists with the control circuit.

The reference for improper function of a hydraulic system, where the cause is not immediately apparent, should be the Troubleshooting Chart. The best place to begin the problem analysis is at the power source (pump). Once it is determined that the pump is serviceable, then a systematic check of the circuit components, beginning with the control, would follow. For aid in troubleshooting, refer to the Illustrated Parts Manual for hydraulic diagrams of the various circuits

SECTION 7 - BASIC TROUBLESHOOTING, ELECTRICAL INFORMATION, & SCHEMATICS

Table 7-1. Platform Assembly - Troubleshooting

TROUBLE	PROBABLE CAUSE	REMEDY
Automatic leveling inoperative.		
	Hydraulic system oil low.	Replenish oil as necessary.
	Dual check valves dirty/inoperative.	Clean or replace as necessary.
	Restricted or broken hydraulic line or fitting on slave cylinder or main lift cylinder.	Clean, repair, or replace line or fitting.
	Worn seal(s) in slave level or main lift cylinder.	Replace seal(s).
	Counterbalance valve in slave cylinder defective.	Replace counterbalance valve.
	Slave level or main lift cylinder not functioning properly.	Slave level or main lift cylinder not functioning properly.
Platform will not maintain level attitude.		
	Counterbalance valve on slave leveling cylinder improperly adjusted or not functioning properly.	Replace valve.
	Worn seal(s) in slave level or main lift cylinder.	Replace seal(s).
	Damaged slave level or main lift cylinder.	Repair or replace cylinder.
No response to platform leveling controls.		
	Level function not activated within 7 seconds after footswitch was depressed.	Recycle footswitch.
	Level control switch inoperative.	Repair or replace control switch lever.
	Hydraulic system oil low.	Replenish oil as necessary.
	Proportional Flow Regulator not powered.	Wiring: Run System Test
	Restricted or broken hydraulic line or fitting.	Clean, repair, or replace line or fitting.
	Directional valve not functioning properly.	Repair or replace valve.
	No electric power to directional control valve.	See proper wiring diagram/Run System Test.
	Slave cylinder not functioning properly.	Repair or replace pump.
Platform will not adjust "up" or "down" to level.		
	Hydraulic pump not functioning properly.	Run System Test.
	Restricted or broken hydraulic line or fitting.	Clean, repair, or replace line or fitting.
	Slave cylinder not functioning properly.	Repair or replace cylinder.
	Electrical failure.	See proper wiring diagram/Run System Test.
	Orifice plugged.	Clean orifice.

SECTION 7 - BASIC TROUBLESHOOTING, ELECTRICAL INFORMATION, & SCHEMATICS

Table 7-1. Platform Assembly - Troubleshooting

TROUBLE	PROBABLE CAUSE	REMEDY
	Proportional Flow Regulator not powered.	Check wiring/Run System Test.
	Personalities not set correctly	Check settings.

SECTION 7 - BASIC TROUBLESHOOTING, ELECTRICAL INFORMATION, & SCHEMATICS

Table 7-2. Boom Assembly - Troubleshooting

TROUBLE	PROBABLE CAUSE	REMEDY
CONTROL VALVES		
Valve spool sticking.		
	Dirt in oil causing excessive temperature build-up.	Flush system and change oil using recommended viscosity
	Moisture in oil.	Flush system and change oil using recommended viscosity
	Incorrect valve mounting causing warping of the unit.	Loosen valve and check mounting. Repair as necessary.
	Valve spool scored.	Remove valve and repair or replace as necessary.
	Tie-bolts in valve over torqued.	Correctly torque bolts.
	Return spring weak or broken.	Remove valve and repair or replace as necessary.
	Relief valve malfunctioning causing excessive pressure within valve.	Check pressure delivery to and from valve and repair or replace as necessary.
Valve leaking.		
	Dirt or other foreign material under seal.	Remove and repair valve as necessary.
	Valve spool scored.	Remove valve and repair or replace as necessary.
	Excessive back pressure caused by restricted return line to reservoir.	Remove line and clear obstruction or replace line as necessary.
	Damaged valve seals.	Remove valve and repair or replace as necessary.
BOOM ELEVATION SYSTEM.		
No response to lift control switch/Joystick.		
	Lift function not activated within 7 seconds after footswitch was depressed.	Recycle footswitch.
	Lift control switch inoperative.	Repair or replace control switch/Run System Test.
	Lift cylinder holding valve inoperative.	Repair or replace holding valve.
	Bypass valve not operating.	Determine cause and repair or replace valve.
	Electrical malfunction.	See wiring diagram/Run System Test.
	Hydraulic system oil low.	Replenish oil as necessary.

SECTION 7 - BASIC TROUBLESHOOTING, ELECTRICAL INFORMATION, & SCHEMATICS

Table 7-2. Boom Assembly - Troubleshooting

TROUBLE	PROBABLE CAUSE	REMEDY
	Restricted or broken supply line on valve bank or hydraulic pump.	Clean or replace line.
	Directional valve not functioning properly.	Repair or replace valve.
	Lift cylinder not functioning properly.	Repair or replace cylinder
Boom will not raise.		
	Lift function not activated within 7 seconds after footswitch was depressed.	Recycle footswitch.
	Load capacity exceeded (personnel or equipment on platform).	Reduce load.(Refer to capacity placard.)
	Lift switch/Joystick not functioning.	Check wiring/Run System Test.
	Hydraulic system oil low.	Replenish oil as necessary.
	Electrical failure to valves.	See proper wiring diagram/Runs System Test.
	Restricted or broken hydraulic line or fitting.	Clean, repair, or replace line or fitting.
	Directional valve not functioning properly.	Repair or replace valve.
	Pressure relief valve not functioning properly.	Re-adjust or replace valve.
	Lift cylinder not functioning properly.	Repair or replace cylinder.
	Binding lift cylinder or boom pivot pin.	Repair or replace cylinder or pin.
Boom will not lower.		
	See: Boom will not raise.	
	Pressure relief valve not functioning properly.	Re-adjust or replace valve.
	Holding valve not functioning properly.	Re-adjust or replace valve.
Boom raises and lowers erratically.		
	Hydraulic system oil low.	Replenish oil as required.
	Restricted or broken hydraulic line or fitting.	Clean, repair, or replace line or fitting.
	Counterbalance valve on lift cylinder improperly adjusted or not functioning properly.	Replace valve.
	Directional valve not functioning properly.	Repair or replace valve.
	Worn seals in lift cylinder.	Replace seals.
	Cylinder not functioning properly.	Repair or replace cylinder.
Boom drifts down.		
	Worn seals in lift cylinder.	Replace seals.

SECTION 7 - BASIC TROUBLESHOOTING, ELECTRICAL INFORMATION, & SCHEMATICS

Table 7-2. Boom Assembly - Troubleshooting

TROUBLE	PROBABLE CAUSE	REMEDY
Function Speed and Drive Speed does not operate below horizontal.		
	Damaged wiring on level limit switch.	Repair or replace wiring/Run System Test
	Creep Switch Open.	Replace switch/Run System Test
	Machine Tilted	Level machine.
	Speed Sensor Failure.	Replace Sensor.
LOWER LIFT FUNCTION.		
If the boom assembly does not fully lower.		
	The Mid and Lower Booms are out of synchronization.	Refer to synchronize procedure.
MAIN TELESCOPE SYSTEM.		
No response to telescope control.		
	Telescope function not activated within 7 seconds after footswitch was depressed.	Recycle footswitch.
	Telescope control switch inoperative.	Repair or replace control switch/Run System Test
	Hydraulic system oil low.	Replenish oil as necessary.
	Damaged wiring on control switch or solenoid valve.	Repair or replace wiring/Run System Test
	Directional valve not functioning properly.	Repair or replace valve.
	Restricted or broken supply line on valve bank or hydraulic pump.	Clean or replace line.
	Proportional Flow Regulator Not Powered.	Check wiring/Run System Test.
	Telescope cylinder not functioning properly.	Repair or replace cylinder.
	Hydraulic pump not functioning properly.	Repair or replace pump/Run System Test.
Boom will not extend.		
	Telescope function not activated within 7 seconds after footswitch was depressed.	Recycle footswitch.
	Directional valve not functioning properly.	Repair or replace control valve.
	Restricted or broken hydraulic line or fitting.	Clean, repair, or replace line or fitting.
	Pressure setting incorrect.	Check pressure/re-adjust as necessary.
	Telescope cylinder not functioning properly.	Repair or replace cylinder.
	Personality Setting incorrect.	Set to Factory Default.

SECTION 7 - BASIC TROUBLESHOOTING, ELECTRICAL INFORMATION, & SCHEMATICS

Table 7-2. Boom Assembly - Troubleshooting

TROUBLE	PROBABLE CAUSE	REMEDY
Boom extends and retracts erratically.		
	Hydraulic system oil low.	Replenish oil as necessary.
	Wear pads worn.	Replace pads as required.
	Restricted or broken hydraulic line or fitting.	Clean, repair, or replace line or fitting.
	Directional valve not functioning properly.	Repair or replace valve.
	Worn seals in telescope cylinder.	Replace seals.
	Cylinder not functioning properly.	Repair or replace cylinder.
	Counterbalance valve not functioning properly.	Replace counterbalance valve.
BOOM SWING SYSTEM		
No response to swing control.		
	Swing function not activated within 7 seconds after footswitch was depressed.	Recycle footswitch.
	Hydraulic system oil low.	Replenish oil as necessary.
	Swing Joystick not functioning.	Repair or replace swing joystick/Run System Test.
	Restricted or broken supply line on valve bank or hydraulic pump.	Clean or replace line.
	Directional valve not functioning properly.	Repair or replace valve.
	Swing motor not functioning properly.	Repair or replace motor.
	Foreign object(s) wedged between swing motor pinion and swing gear.	Remove objects, check for damage, and repair or replace component(s) as required.
	No electric power to valve.	See proper wiring diagram/Run System Test.
Boom will swing in one direction only.		
	Restricted or broken hydraulic line or fitting.	Clean, repair, or replace line or fitting.
	Directional valve not functioning properly.	Repair or replace valve.
	Foreign object(s) wedged between swing motor pinion and swing gear.	Remove object(s), check for damage and repair or replace component(s) as required.
	Swing Joystick not functioning properly.	Repair or replace swing joystick/Run System Test.

SECTION 7 - BASIC TROUBLESHOOTING, ELECTRICAL INFORMATION, & SCHEMATICS

Table 7-2. Boom Assembly - Troubleshooting

TROUBLE	PROBABLE CAUSE	REMEDY
Boom swings erratically in either direction.		
	Hydraulic system oil low. Lack of lubricant on swing gear or speed reducer pinion. Swing motor not functioning properly. Worn or broken teeth on swing gear or swing motor pinion. Restrictor valves(s) plugged.	Replenish oil as necessary. Lubricate as required. (See Lubrication Chart.) Repair or replace swing control switch. Replace gear(s) as required. Clean or replace restrictor valve.

SECTION 7 - BASIC TROUBLESHOOTING, ELECTRICAL INFORMATION, & SCHEMATICS

Table 7-3. Turntable Assembly - Troubleshooting

TROUBLE	PROBABLE CAUSE	REMEDY
CONTROL VALVE.		
Valve Spool Sticking.		
	Dirt in oil causing excessive temperature built-up. Incorrect valve mounting causing warping of the unit. Valve spool scored. Return spring weak or broken. Relief valve malfunctioning causing excessive pressure within valve.	Change oil using recommended viscosity and flush system. Loosen valve and check mounting. Repair as necessary. Remove valve and repair or replace as necessary. Remove valve and repair or replace as necessary. Check pressure delivery to and from valve and repair or replace as necessary.
Valve leaking.		
	Dirt or other foreign material under seal. Valve spool scored. Excessive back pressure caused by restricted return line to reservoir. Damaged valve seals.	Remove and replace valve as necessary. Repair or replace valve. Remove line and clear obstruction or replace line as necessary. Repair or replace valve as necessary.

SECTION 7 - BASIC TROUBLESHOOTING, ELECTRICAL INFORMATION, & SCHEMATICS

Table 7-4. Chassis Assembly - Troubleshooting

TROUBLE	PROBABLE CAUSE	REMEDY
GENERATOR.		
Engine will not start.		
	Enable switch is open.	Actuate switch.
	Fuses open.	Determine and correct cause; replace fuse.
	Ground EMS is open.	Pull out EMS to activate.
	Defective starter motor.	Replace starter motor.
	Damaged wiring in ignition circuit (broken wire on starter).	Repair, replace wiring.
	Manual start switch not functioning properly.	Replace switch/check wiring.
	Ignition relay not functioning properly.	Replace relay.
	Ignition circuit shorted to ground.	See proper wiring diagram.
	Battery cable(s) not making contact.	Clean and tighten cable(s).
Engine will not start (ignition OK).		
	No fuel.	Replenish fuel as necessary.
	Clogged fuel filter.	Replace fuel filter.
	Choke solenoid malfunction.	Replace choke solenoid.
	Restricted or broken fuel line.	Clean or replace fuel line.
	Fuel shut-off valve in carburetor stuck or frozen.	Repair or replace fuel shut-off. Check for electrical power.
	Battery discharged.	Charge battery, replace if defective.
	Cam timing belt jumped time or broken.	Repair or replace timing belt.
	Ignition timing slipped.	Repair timing.
Engine surges.		
	Governor not adjusted properly.	Correctly adjust governor.
Strong fuel odor.		
	Fuel tank overfilled.	Check fuel tank and immediately wipe up spilled fuel.
	Fuel tank damaged.	Drain all fuel from tank and remove tank for replacement or repair.
	Fuel line from tank damaged.	Replace fuel line.
	Carburetor flooding.	Repair, replace or adjust carburetor.

SECTION 7 - BASIC TROUBLESHOOTING, ELECTRICAL INFORMATION, & SCHEMATICS

Table 7-4. Chassis Assembly - Troubleshooting

TROUBLE	PROBABLE CAUSE	REMEDY
FRONT FRAME AXLE AREA.		
One or both wheels will not steer.		
	Steering link or tie rod broken or attaching hardware missing.	Replace steering link, tie rod or hardware as necessary.
One or both front wheels will not rotate or rotate erratically.		
	Wheel hub or bearings damaged or not lubricated.	Replace hub or bearings as necessary and repack bearings with approved grease.
REAR FRAME AXLE AREA.		
Difficulty encountered when moving machine.		
	Load capacity exceeded.	Reduce load. Apply loads only in accordance with load capacity indicator.
	Hubs Disconnected.	Engage hubs as outlined in Operators Manual.
	Machine being moved up too steep a grade.	Remove machine from grade and check that drive system operates correctly.
	Grade too steep.	See WARNING Placard on platform for specified grades and sideslopes.
	Towing valve not closed.	Close towing valve.
	Drive wheel tire treads worn smooth.	Replace tires as necessary and inflate to specified pressure.
	Drive brakes "dragging".	Re-adjust pressure.
	System pressure too low.	Re-adjust pressure.
	Drive hub(s) defective.	Repair or replace hub.
DRIVE SYSTEM.		
No response to control.		
	Drive function not activated within 7 seconds after footswitch was depressed.	Recycle footswitch.
	Hydraulic system oil low.	Replenish oil as necessary.
	Hydraulic pump not functioning properly.	Repair or replace pump.
	Restricted or broken pump supply line.	Clean, repair or replace line.
	Restricted or broken line on valve bank.	Clean, repair or replace line.
	Air in wheel brake circuit.	Bleed circuit, determine and correct cause.
	Damaged wiring on joystick.	Repair or replace wiring /Run System Test.

SECTION 7 - BASIC TROUBLESHOOTING, ELECTRICAL INFORMATION, & SCHEMATICS

Table 7-4. Chassis Assembly - Troubleshooting

TROUBLE	PROBABLE CAUSE	REMEDY
	Joystick not functioning properly.	Replace joystick/Run System Test.
	Charger plugged in.	Check help message.
	Drive prevented.	Check help message.
	Brake(s) not releasing.	Determine cause and repair or replace.
Machine will not travel in forward.		
	Hydraulic system oil low.	Replenish oil as necessary.
	Restricted or broken hydraulic line or fitting.	Clean, repair or replace line or fitting.
Motor turns slowly at maximum command.		
	Cutback - Tilted	Check help message.
	Speed Sensor	Check help message.
	Cutback - Elevation.	Check elevation switch.
Poor response, function shuts off slowly when command is removed.		
	Ramp set too high in controller.	Check personality.
	Sticking control handle.	Repair or replace controller.
STEERING SYSTEM.		
No response to steer control.		
	Hydraulic system pressure too low.	Adjust pressure.
	Damaged wiring on control switch or solenoid valve.	Check wiring/Run System test.
	Control switch not functioning properly.	Run system test.
	Restricted or broken hydraulic line on valve bank, hydraulic pump or rotary coupling. (If equipped.)	Clean, repair or replace line.
	Steer proportional flow valve not functioning properly.	Run System Test.
	Steer control valve not functioning properly.	Repair or replace valve.
	Steer cylinder not functioning properly.	Repair or replace cylinder.
Machine hard to steer or steering is erratic.		
	Hydraulic system oil low.	Replenish oil as necessary.
	Restricted hydraulic line or fitting.	Clean, repair or replace line or fitting.
	Steer system pressure low.	Adjust pressure.
	Bent linkage (tie rods).	Repair or replace linkage as required.

SECTION 7 - BASIC TROUBLESHOOTING, ELECTRICAL INFORMATION, & SCHEMATICS

Table 7-4. Chassis Assembly - Troubleshooting

TROUBLE	PROBABLE CAUSE	REMEDY
	Proportional Flow Valve not functioning properly.	Repair or replace valve.
	Hydraulic pump not functioning properly.	Repair or replace pump.
	Personality Settings Incorrect.	Adjust settings.
	Steer cylinder not functioning properly.	Repair or replace cylinder.
Steering inoperative.		
	Damaged wiring on control switch or solenoid valve.	See proper wiring diagram/Run System Test.
	Solenoid valve not functioning properly.	Repair or replace valve.
	Control switch not functioning properly.	Replace switch/Run System Test.
	Relief valve improperly set or not functioning properly.	Reset, repair or replace valves as required.
	Steer cylinder not functioning properly.	Repair or replace cylinder.
Machine will not steer left or to the right.		
	Wiring on control switch is damaged.	See proper wiring diagram/Run System Test.
	Wiring on solenoid valve damaged.	Repair or replace wiring/Run System Test.
	Coil in solenoid damaged.	Replace coil.
	No oil flow or pressure to steer circuit.	Take pressure reading at steer valve and adjust as necessary.
	Bent cylinder rod.	Repair or replace cylinder.
	Damaged tie rod.	Replace tie rod.
	Cylinder packing defective.	Repair or replace cylinder.
Machine wanders; steering not firm.		
	Crossover relief valve set too low or not functioning properly.	Reset, repair or replace valve as required.
	Steer linkages loose.	Tighten linkage.
	Steer wheel toe-in not set properly.	Adjust toe-in for 1/4 inch overall.
	Spindle bushings badly worn.	Replace bushings.
DRIVE BRAKE.		
Brake Slips		
	Excessive pressure in hydraulic system.	Check hydraulic filter, restrictions in other hydraulic components.
	Disc plates worn.	Check disc thickness.
	Springs broken or have taken a permanent set.	Check release pressure.

SECTION 7 - BASIC TROUBLESHOOTING, ELECTRICAL INFORMATION, & SCHEMATICS

Table 7-4. Chassis Assembly - Troubleshooting

TROUBLE	PROBABLE CAUSE	REMEDY
Brake Drags or runs hot.		
	Low actuation pressure.	Place pressure gauge in bleed port & check pressure with system on.
	Bearing failure.	Replace bearing.
Brake will not release.		
	Stuck or clogged valve.	Place pressure gauge in bleed port - check for adequate pressure. Replace defective line or component.
	Bad o-rings.	Replace o-rings.
	Discs frozen.	Replace disc stack.

SECTION 7 - BASIC TROUBLESHOOTING, ELECTRICAL INFORMATION, & SCHEMATICS

Table 7-5. Hydraulic System - Troubleshooting

TROUBLE	PROBABLE CAUSE	REMEDY
HYDRAULIC SYSTEMS - GENERAL.		
Hydraulic pump noisy.		
	Air entering system through broken line or fitting. (Suction Side.)	Repair or replace line or fitting.
	Air bubbles in oil. (Reservoir oil too low.	Replenish oil as required.
	Suction hose squeezed shut.	Determine cause and repair.
	Oil filter dirty.	Replace hydraulic filter.
	Wrong type of hydraulic oil.	Replace hydraulic oil.
Pump cavitating. (Vacuum in pump due to oil starvation.)		
	Restricted suction line.	Clean, repair, or replace line.
	Restricted reservoir air vent.	Clean or replace vent.
	Oil viscosity too high.	Drain system and replace with recommended oil. (Refer to Hydraulic Oils.)
	Air leak in suction side of tank.	Repair leak.
System overheating.		
	Oil viscosity too high.	Drain system and replace with recommended oil. (Refer to Hydraulic Oils.)
	Bypass valve not operating properly.	Repair or replace valve.
	Main relief valve set too low.	Reset valve as required.
	Hydraulic system oil low.	Replenish oil as necessary.
	Port relief set too high.	Reset valve as required.
	Restricted or blocked return line.	Repair or replace line.
Pump not delivering oil.		
	Restricted suction line.	Clean, repair, or replace line.
	Air entering system through broken line or fitting.	Repair or replace line or fitting.
	Broken pump drive shaft/pump coupling.	Repair or replace pump/pump coupling. Note: Any time pump or pump drive coupling is removed coat pump and drive coupling splines with Lithium Soap Base Grease (TEX-ACO CODE 1912 OR EQUIVALENT).

SECTION 7 - BASIC TROUBLESHOOTING, ELECTRICAL INFORMATION, & SCHEMATICS

Table 7-5. Hydraulic System - Troubleshooting

TROUBLE	PROBABLE CAUSE	REMEDY
Function sluggish during operation. (System pressure too low.)		
	Main relief valve set too low. Pump section not delivering sufficient oil. Main relief valve stuck in open position. Oil viscosity too low. Leak in component, line or fitting. Scored valve spool; scored cylinder. Hydraulic Filter clogged. Amperage too low on controller. Low voltage in electrical system.	Reset valve as required. Repair or replace pump section or pump. Clean, repair, or replace valve. (Check system oil for contamination.) Drain system and replace with recommended oil. (Refer to Hydraulic Oils.) Repair or replace component, line or fitting. Replace valve; replace cylinder. Replace filter. Correctly adjust controller. Correct low voltage problem.
System(s) operate erratically.		
	Sticking or binding valve spools, pistons.	Clean, repair, or replace components as required.

SECTION 7 - BASIC TROUBLESHOOTING, ELECTRICAL INFORMATION, & SCHEMATICS

Table 7-6. Electrical System - Troubleshooting

TROUBLE	PROBABLE CAUSE	REMEDY
PLATFORM CONTROLS.		
No power to platform controls.		
	15 Amp self-reset circuit breaker open.	Check footswitch to ensure that both switches are making contact when pedal is depressed. Repair or replace footswitch as necessary.
	Contact block in footswitch malfunctioning.	Repair, replace or adjust contact block as required.
	Faulty power circuit wiring.	Check wiring continuity. Refer to proper wiring diagram.
	Platform EMS or Ground EMS switch in wrong position.	Place switch to correct position.
ENGINE STARTER SYSTEM (GENERATOR).		
Starter will not crank.		
	Discharged battery or loose battery terminals.	Check and charge battery or replace battery as necessary. Clean and secure battery terminals.
	Starter relay faulty or faulty relay connections.	Using a test meter, check relay coil terminals for presence of electrical power and for energization of relay coil. Also check relay terminals for correct switching of contacts. Replace relay as necessary.
	Malfunctioning starter solenoid or motor.	Replace solenoid or motor in accordance with applicable manufacturer's manual.
	Malfunctioning manual start switch.	Using a test meter, check ignition switch for correct switching of contacts. Replace switch as necessary.
	Faulty ignition and/or starter circuit wiring.	Check wiring continuity. See proper wiring diagram.
	Faulty start switch.	Replace switch.
INSTRUMENTS AND INDICATORS.		
Travel warning horn inoperative.		
	Machine set-up incorrect.	Adjust control module settings properly.
	Damaged wiring in horn circuit.	Repair or replace wiring/Run System Test.
	Damaged horn.	Replace horn.

SECTION 7 - BASIC TROUBLESHOOTING, ELECTRICAL INFORMATION, & SCHEMATICS

Table 7-6. Electrical System - Troubleshooting

TROUBLE	PROBABLE CAUSE	REMEDY
Hourmeter inoperative.		
	Damaged wiring in hourmeter circuit.	Repair or replace wiring.
	Inoperative hourmeter.	Replace hourmeter.
Platform alarm circuit.		
	Platform alarm inoperative.	Check platform alarm/Run System Test.
	Defective bulb in tilt light.	Replace bulb.

7.3 MULTIMETER BASICS

A wide variety of multimeters or Volt Ohm Meters (VOM) can be used for troubleshooting your equipment. This section shows diagrams of a common, digital VOM configured for several different circuit measurements. Instructions for your VOM may vary. Please consult the meter operator's manual for more information.

Grounding

"Grounding the meter" means to take the black lead (which is connected to the COM (common) or negative port) and touch it to a good path to the negative side of the Voltage source.

Backprobing

To "backprobe" means to take the measurement by accessing a connector's contact on the same side as the wires, the back of the connector. Readings can be done while maintaining circuit continuity this way. If the connector is the sealed type, great care must be taken to avoid damaging the seal around the wire. It is best to use probes or probe tips specifically designed for this technique, especially on sealed connectors. Whenever possible insert probes into the side of the connector such that the test also checks both terminals of the connection. It is possible to inspect a connection within a closed connector by backprobing both sides of a connector terminal and measuring resistance. Do this after giving each wire a gentle pull to ensure the wires are still attached to the contact and contacts are seated in the connector.

Min/Max

Use of the "Min/Max" recording feature of some meters can help when taking measurements of intermittent conditions while alone. For example, you can read the Voltage applied to a solenoid when it is only operational while a switch, far from the solenoid and meter, is held down.

Polarity

Getting a negative Voltage or current reading when expecting a positive reading frequently means the leads are reversed. Check what reading is expected, the location of the signal and that the leads are connected to the device under test correctly. Also check that the lead on the "COM" port goes to the Ground or negative side of the sig-

nal and the lead on the other port goes to the positive side of the signal.

Scale

M = Mega = 1,000,000 * (Displayed Number)

k = kilo = 1,000 * (Displayed Number)

m = milli = (Displayed Number) / 1,000

μ = micro = (Displayed Number) / 1,000,000

Example: 1.2 k Ω = 1200 Ω

Example: 50 mA = 0.05 A

Voltage Measurement

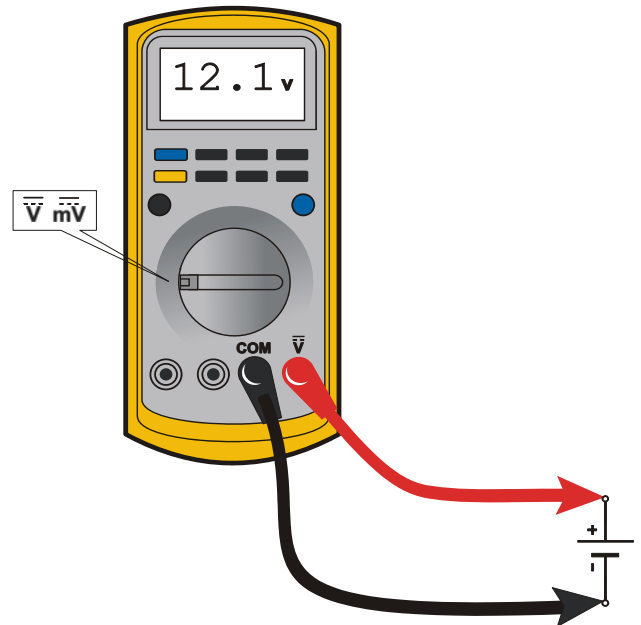

Figure 7-1. Voltage Measurement (DC)

- If meter is not auto ranging, set it to the correct range (See multimeter's operation manual)
- Use firm contact with meter leads

Resistance Measurement

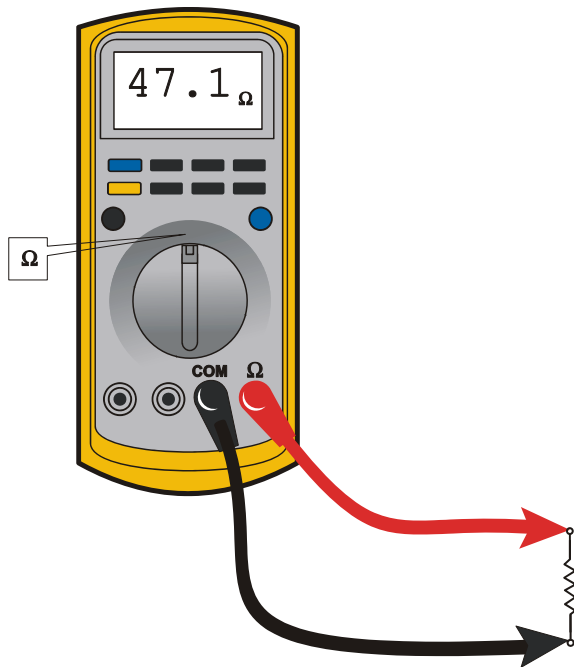

Figure 7-2. Resistance Measurement

- First test meter and leads by touching leads together. Resistance should read a short circuit (very low resistance)
- Circuit power must be turned OFF before testing resistance
- Disconnect component from circuit before testing
- If meter is not auto ranging, set it to the correct range (See multimeter's operation manual)

- Use firm contact with meter leads

Continuity Measurement

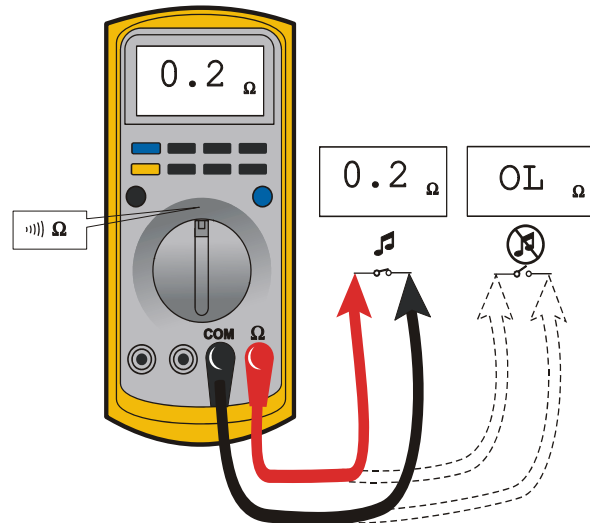

Figure 7-3. Continuity Measurement

- Some meters require a separate button press to enable audible continuity testing
- Circuit power must be turned OFF before testing continuity
- Disconnect component from circuit before testing
- Use firm contact with meter leads
- First test meter and leads by touching leads together. Meter should produce an audible alarm, indicating continuity

Current Measurement

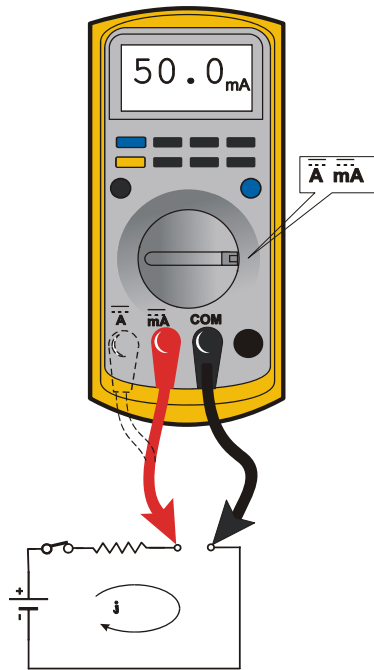

Figure 7-4. Current Measurement (DC)

- Set up the meter for the expected current range
- Be sure to connect the meter leads to the correct jacks for the current range you have selected
- If meter is not auto ranging, set it to the correct range (See multi meter's operation manual)
- Use firm contact with meter leads

7.4 CHECKING SWITCHES

Basic Check

The following check determines if the switch is functioning properly, not the circuit in which the switch is placed. A switch is functioning properly when there is continuity between the correct terminals or contacts only when selected.

1. De-energize the circuit.
2. Isolate the switch from the rest of the circuit if possible. If not possible, keep in mind it may affect readings.
3. Access the terminals to the switch.
4. If the switch has two terminals:
 - a. Measure resistance across the terminals.

- b. Change the switch position.
 - c. Measure resistance again with the leads in the same positions. If the meter was reading short, it should read an open. If the meter was reading open it should read short.
5. If the switch has more than two terminals, consult the schematic or switch diagram to determine what terminals will be connected. The test is similar to testing a switch with two terminals.
 - a. Place one meter lead on the common contact and the other on a different contact in the same circuit.
 - b. Cycle through all positions of the switch. The meter should read short only when the switch connects the two terminals and open otherwise.
 - c. If the switch has more than one common contact repeat the process for that circuit.

Limit Switches

Limit switches are used to control movement or indicate position. Mechanical limit switches are just like manually operated switches except that the moving object operates the switch. These switches can be tested the same way as a standard switch by manually operating the sensing arm.

Another type of limit switch used by JLG is the inductive proximity switch, also referred to as a "prox switch". Inductive proximity switches are actuated only by ferrous metal (metal that contains Iron, such as steel) near the switch. They do not require contact, and must be energized to actuate. These types of switches can be used to detect boom or platform position, for example. These switches have a sensing face where the switch can detect ferrous metal close to it. To find the sensing face, take note how the switch is mounted and how the mechanisms meet the switch. Test this type of switch as follows:

1. Remove prox switch from its mount.
2. Reconnect harness if it was disconnected for step a, and turn on machine.
3. Hold switch away from metal and observe switch state in the control system diagnostics using the Analyzer. See vehicle or control system documentation on how to do this.
4. Place sensing face of switch on the object to be sensed by the switch. If that is not available, use a piece of ferrous metal physically similar to it. The switch state in the control system diagnostics should change.
5. When reinstalling or replacing switch be sure to follow mounting instructions and properly set the gap between the switch and object sensed.

Automatic Switches

If the switch is actuated automatically, by temperature or pressure for example, find a way to manually actuate the switch to test it. Do this either by applying heat or pressure, for example, to the switch. These switches may need to be energized to actuate.

1. Connect instrumentation to monitor and/or control the parameter the switch is measuring.
2. Observe switch state in control system with the Analyzer. See vehicle or control system documentation on how to do this.
3. Operate system such that the switch actuates. This could be going over a certain pressure or temperature, for example. The state indicated in the control system should change.

Switch Wiring - Low Side, High Side

When controlling a load, a switch can be wired between the positive side of the power source and the load. This switch is called a "high side" switch. The switch supplies the power to the load. When a switch is wired between the negative side of the power source and the load, it is a "low side" switch. The switch provides the ground to the load.

A low side switch will allow voltage to be present on the load. No power is applied because the switch is stopping current flow. This voltage can be seen if the measurement is taken with one test lead on the load and the other on the battery negative side or grounded to the vehicle. What is actually being measured is the voltage drop across the switch. This could mislead a technician into thinking the load is receiving power but not operating. To produce an accurate picture of power or voltage applied to the load, measure voltage across the load's power terminals. Also, the technician can measure the voltage at both power terminals with respect to battery ground. The difference between those two measurements is the voltage applied to the load.

7.5 APPLYING SILICONE DIELECTRIC COMPOUND TO ELECTRICAL CONNECTIONS

NOTE: Do NOT apply dielectric grease to the following connections:

- Main Boom Rotary sensor connections (on Celesco Sensor),

- LSS Modules connections,
- Deutz EMR 2 ECM connection.

Silicone Dielectric Compound must be used on all electrical connections except for those mentioned above for the following reasons:

- To prevent oxidation at the mechanical joint between male and female pins.
- To prevent electrical malfunction caused by low level conductivity between pins when wet.

Use the following procedure to apply Silicone Dielectric Compound to the electrical connectors. This procedure applies to all plug connections not enclosed in a box. Silicone grease should not be applied to connectors with external seals.

1. To prevent oxidation, silicone grease must be packed completely around male and female pins on the inside of the connector prior to assembly. This is most easily achieved by using a syringe.

NOTE: Over a period of time, oxidation increases electrical resistance at the connection, eventually causing circuit failure.

2. To prevent shorting, silicone grease must be packed around each wire where they enter the outside of the connector housing. Also, silicone grease must be applied at the joint where the male and female connectors come together. Any other joints (around strain reliefs, etc.) where water could enter the connector should also be sealed.

NOTE: This condition is especially common when machines are pressure washed since the washing solution is much more conductive than water.

3. Silicone grease should be applied at the time and location of the final connection of the pins into the housings, and plugs into receptacles. This will minimize exposure to the elements as a lubricated (wet) connector.
4. Anderson connectors for the battery boxes and battery chargers should have silicone grease applied to the contacts only.

NOTE: Curing-type sealants might also be used to prevent shorting and would be less messy, but would make future pin removal more difficult.

7.6 AMP CONNECTOR

Applying Silicone Dielectric Compound to AMP Connectors

Silicone Dielectric Compound must be used on the AMP connections for the following reasons:

- To prevent oxidation at the mechanical joint between male and female pins.
- To prevent electrical malfunction caused by low level conductivity between pins when wet.

Use the following procedure to apply Silicone Dielectric Compound to the electrical connectors.

1. To prevent oxidation and low level conductivity, silicone dielectric grease must be packed completely around male and female pins on the inside of the connector after the mating of the housing to the header. This is easily achieved by using a syringe to fill the header with silicone dielectric compound, to a point just above the top of the male pins inside the header. When assembling the housing to the header, it is possible that the housing will become air locked, thus preventing the housing latch from engaging.
2. Pierce one of the unused wire seals to allow the trapped air inside the housing to escape.
3. Install a hole plug into this and/or any unused wire seal that has silicone dielectric compound escaping from it.

Assembly

Check to be sure the wedge lock is in the open, or as-shipped, position (See Figure 7-5.). Proceed as follows:

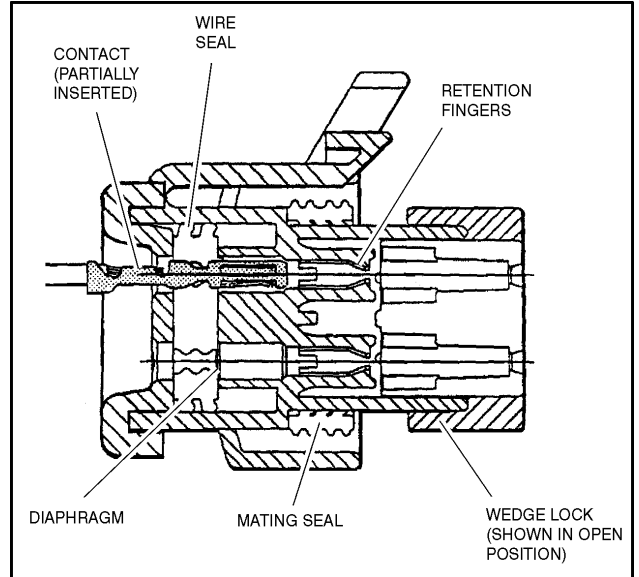

Figure 7-5. Connector Assembly Figure 1

1. To insert a contact, push it straight into the appropriate circuit cavity as far as it will go (See Figure 7-7.).
2. Pull back on the contact wire with a force of 1 or 2 lbs. to be sure the retention fingers are holding the contact (See Figure 7-7.).

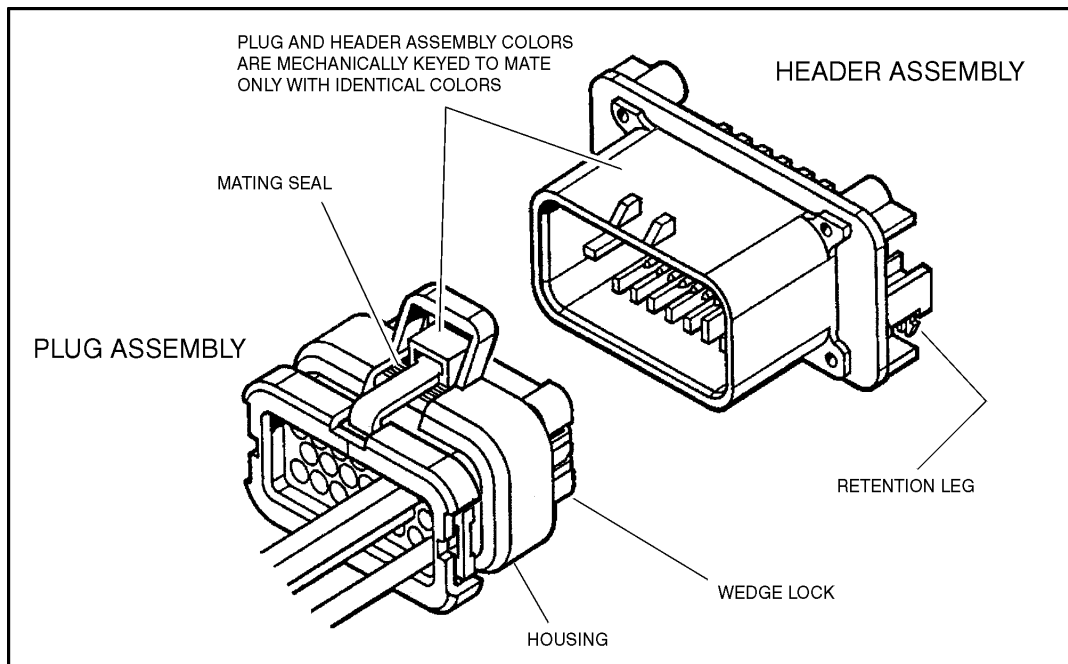

Figure 7-6. AMP Connector

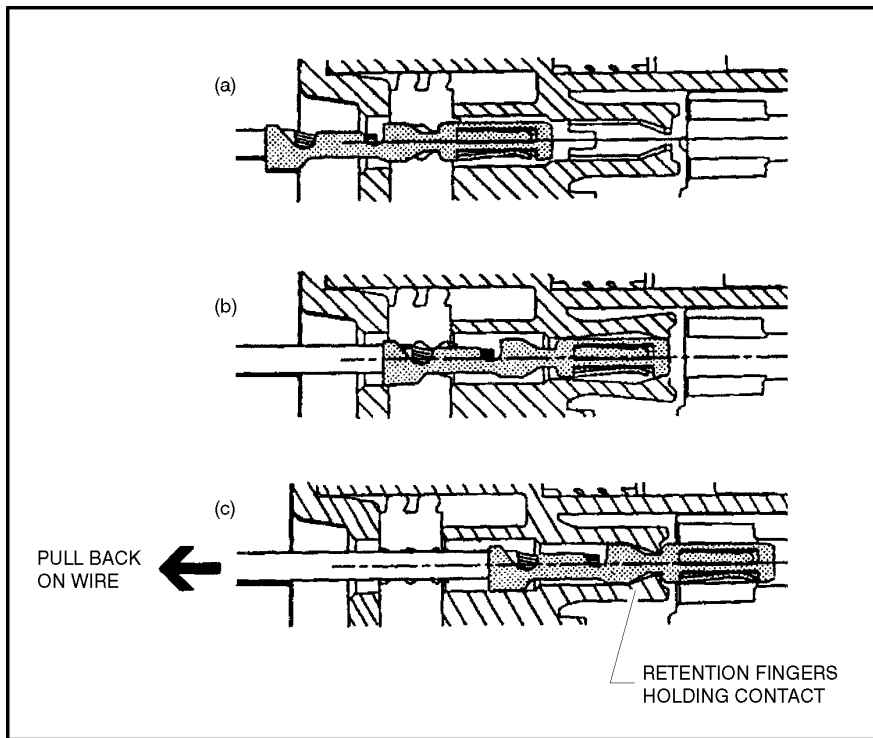

Figure 7-7. Connector Assembly Figure 2

3. After all required contacts have been inserted, the wedge lock must be closed to its locked position. Release the locking latches by squeezing them inward (See Figure 7-8.).

4. Slide the wedge lock into the housing until it is flush with the housing (See Figure 7-9.).

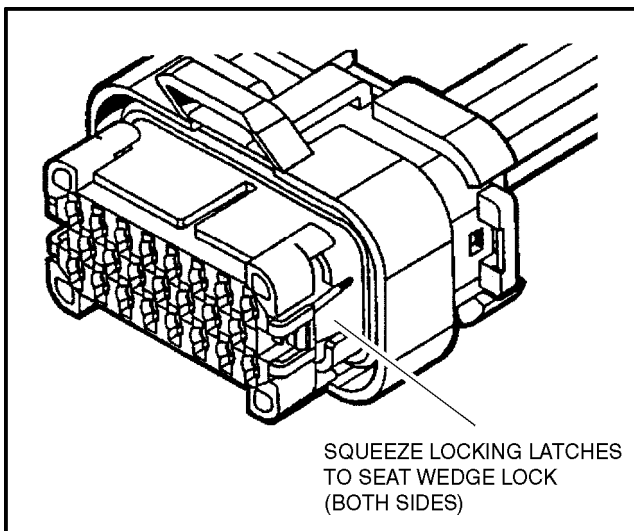

Figure 7-8. Connector Assembly Figure 3

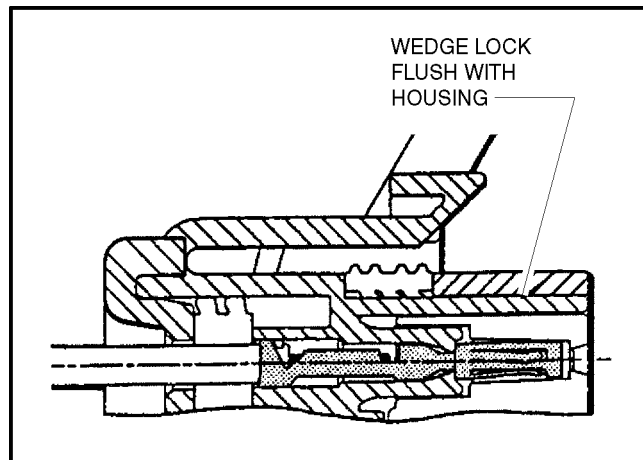

Figure 7-9. Connector Assembly Figure 4

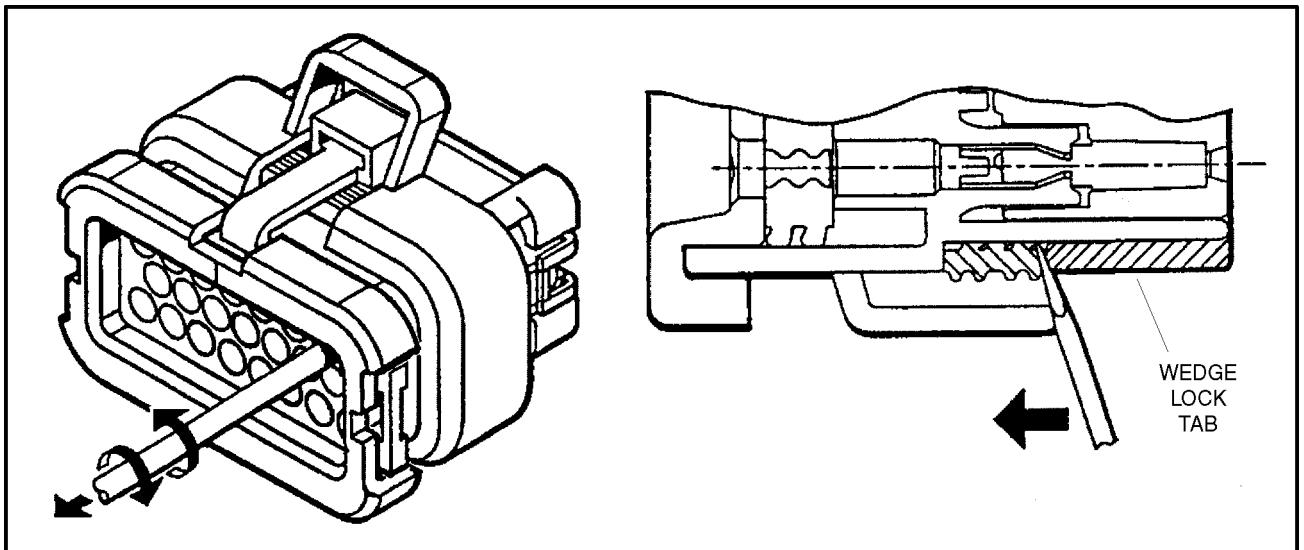

Figure 7-10. Connector Disassembly

Disassembly

1. Insert a 4.8 mm (3/16") wide screwdriver blade between the mating seal and one of the red wedge lock tabs.
2. Pry open the wedge lock to the open position.
3. While rotating the wire back and forth over a half turn (1/4 turn in each direction), gently pull the wire until the contact is removed.

NOTE: The wedge lock should never be removed from the housing for insertion or removal of the contacts.

Wedge Lock

The wedge lock has slotted openings in the forward, or mating end. These slots accommodate circuit testing in the field, by using a flat probe such as a pocket knife. DO NOT use a sharp point such as an ice pick.

Service - Voltage Reading

CAUTION

DO NOT PIERCE WIRE INSULATION TO TAKE VOLTAGE READINGS.

It has been common practice in electrical troubleshooting to probe wires by piercing the insulation with a sharp point. This practice should be discouraged when dealing with the AMPSEAL plug assembly, or any other sealed connector system. The resulting pinholes in the insulation will allow moisture to invade the system by traveling along the wire strands. This nullifies the effectiveness of the connector seals and could result in system failure.

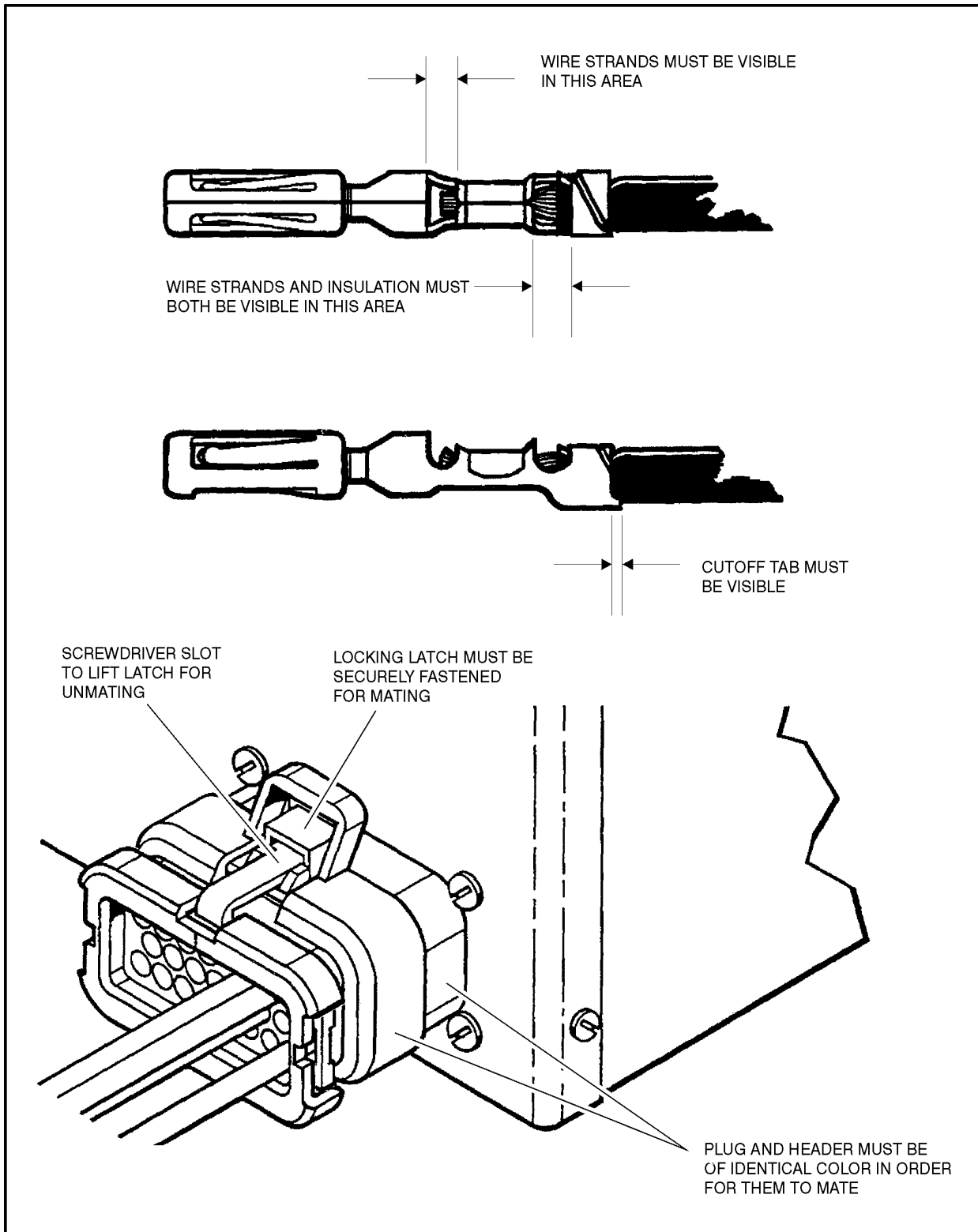

Figure 7-11. Connector Installation

7.7 DEUTSCH CONNECTORS

DT/DTP Series Assembly

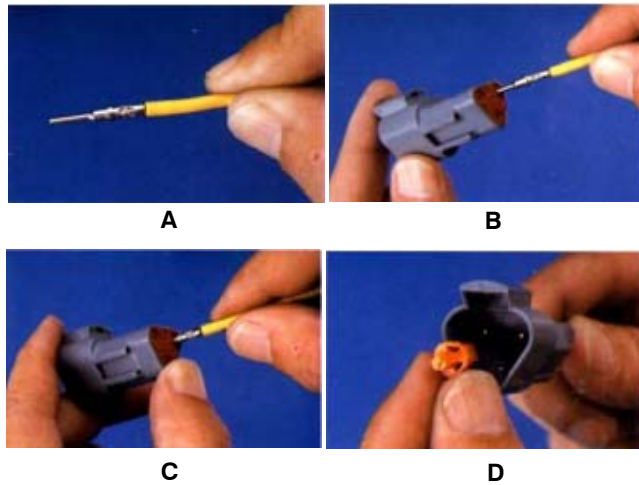

Figure 7-12. DT/DTP Contact Installation

1. Grasp crimped contact about 25mm behind the contact barrel.
2. Hold connector with rear grommet facing you.
3. Push contact straight into connector grommet until a click is felt. A slight tug will confirm that it is properly locked in place.
4. Once all contacts are in place, insert wedgelock with arrow pointing toward exterior locking mechanism. The wedgelock will snap into place. Rectangular wedges are not oriented. They may go in either way.

NOTE: The receptacle is shown - use the same procedure for plug.

DT/DTP Series Disassembly

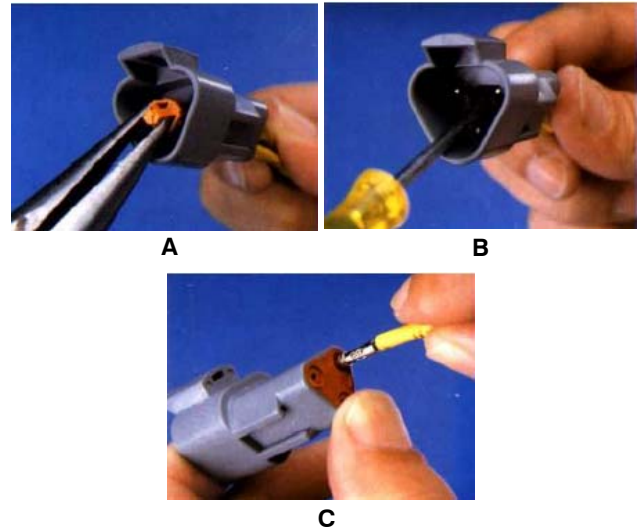

Figure 7-13. DT/DTP Contact Removal

1. Remove wedgelock using needlenose pliers or a hook shaped wire to pull wedge straight out.
2. To remove the contacts, gently pull wire backwards, while at the same time releasing the locking finger by moving it away from the contact with a screwdriver.
3. Hold the rear seal in place, as removing the contact may displace the seal.

HD30/HDP20 Series Assembly

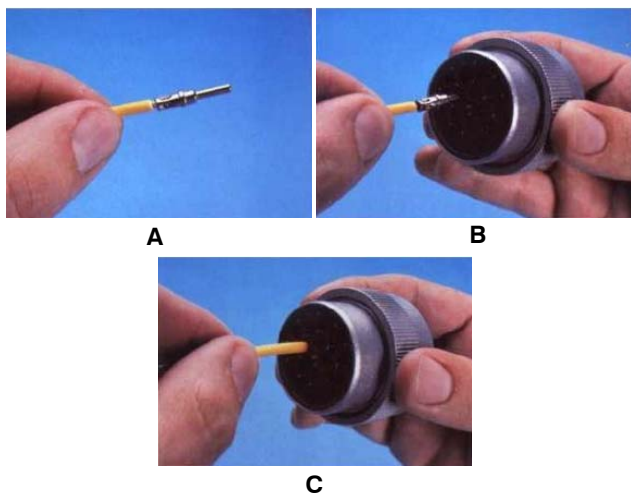

Figure 7-14. HD/HDP Contact Installation

1. Grasp contact about 25mm behind the contact crimp barrel.
2. Hold connector with rear grommet facing you.
3. Push contact straight into connector grommet until a positive stop is felt. A slight tug will confirm that it is properly locked in place.

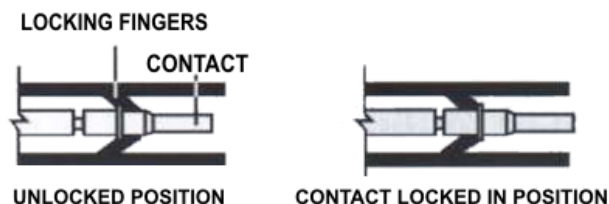

Figure 7-15. HD/HDP Locking Contacts Into Position

NOTE: For unused wire cavities, insert sealing plugs for full environmental sealing

HD30/HDP20 Series Disassembly

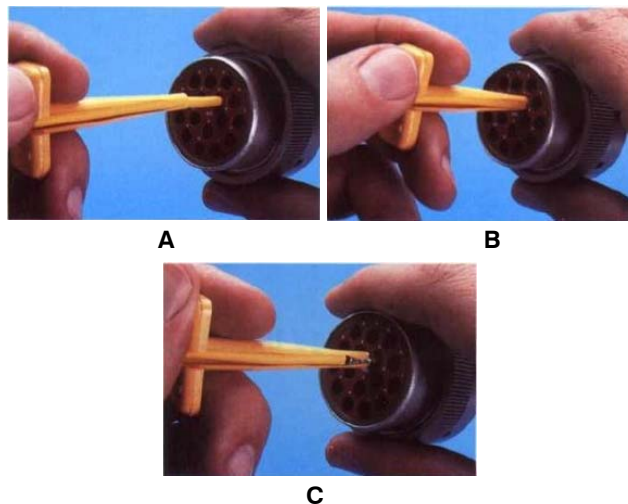

Figure 7-16. HD/HDP Contact Removal

1. With rear insert toward you, snap appropriate size extractor tool over the wire of contact to be removed.
2. Slide tool along into the insert cavity until it engages contact and resistance is felt.
3. Pull contact-wire assembly out of connector.

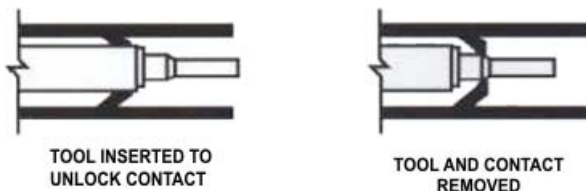

Figure 7-17. HD/HDP Unlocking Contacts

NOTE: Do Not twist or insert tool at an angle.

This page left blank intentionally.

SECTION 7 - BASIC TROUBLESHOOTING, ELECTRICAL INFORMATION, & SCHEMATICS

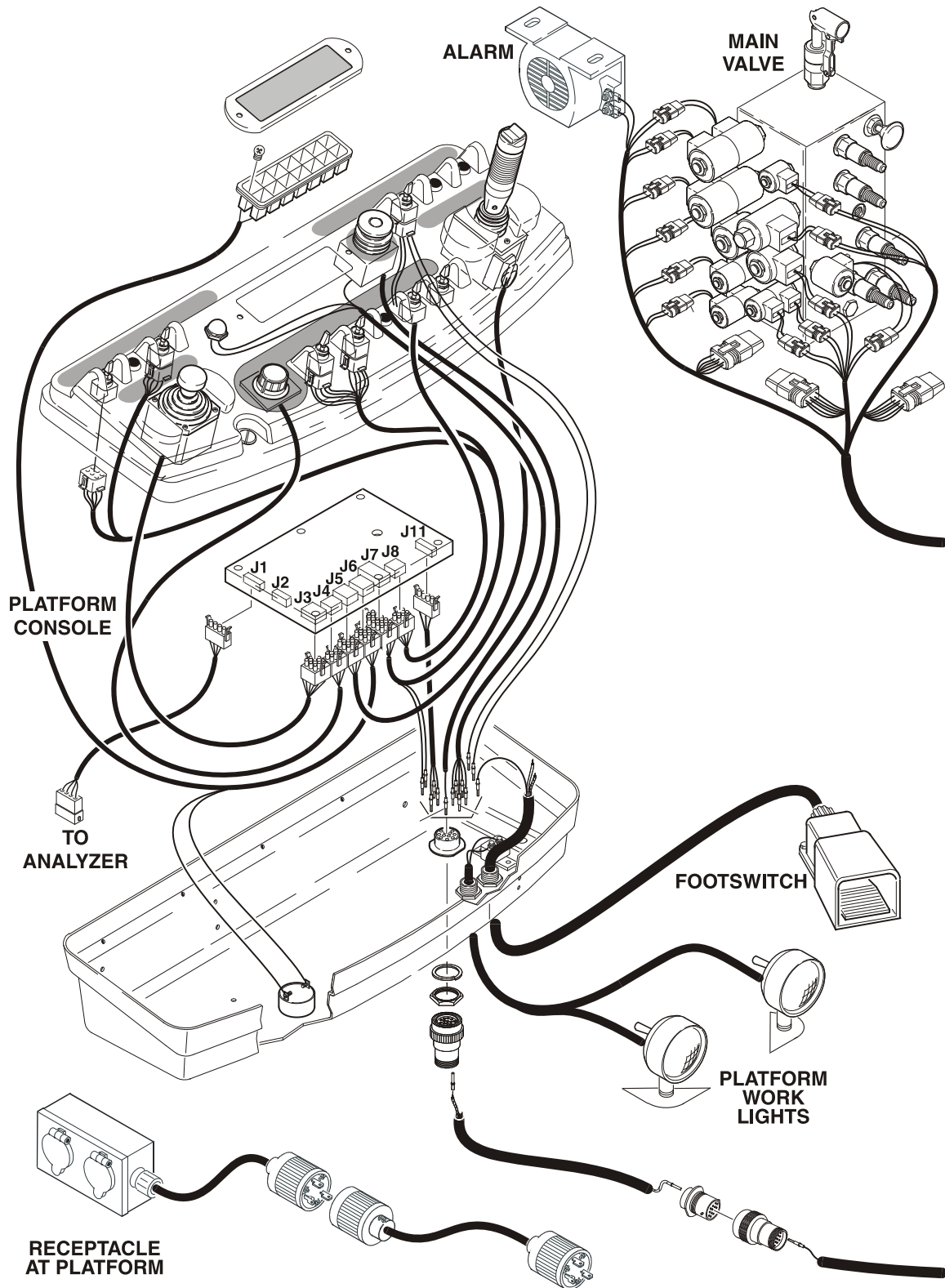

Figure 7-18. Electrical Components Installation - Sheet 1

SECTION 7 - BASIC TROUBLESHOOTING, ELECTRICAL INFORMATION, & SCHEMATICS

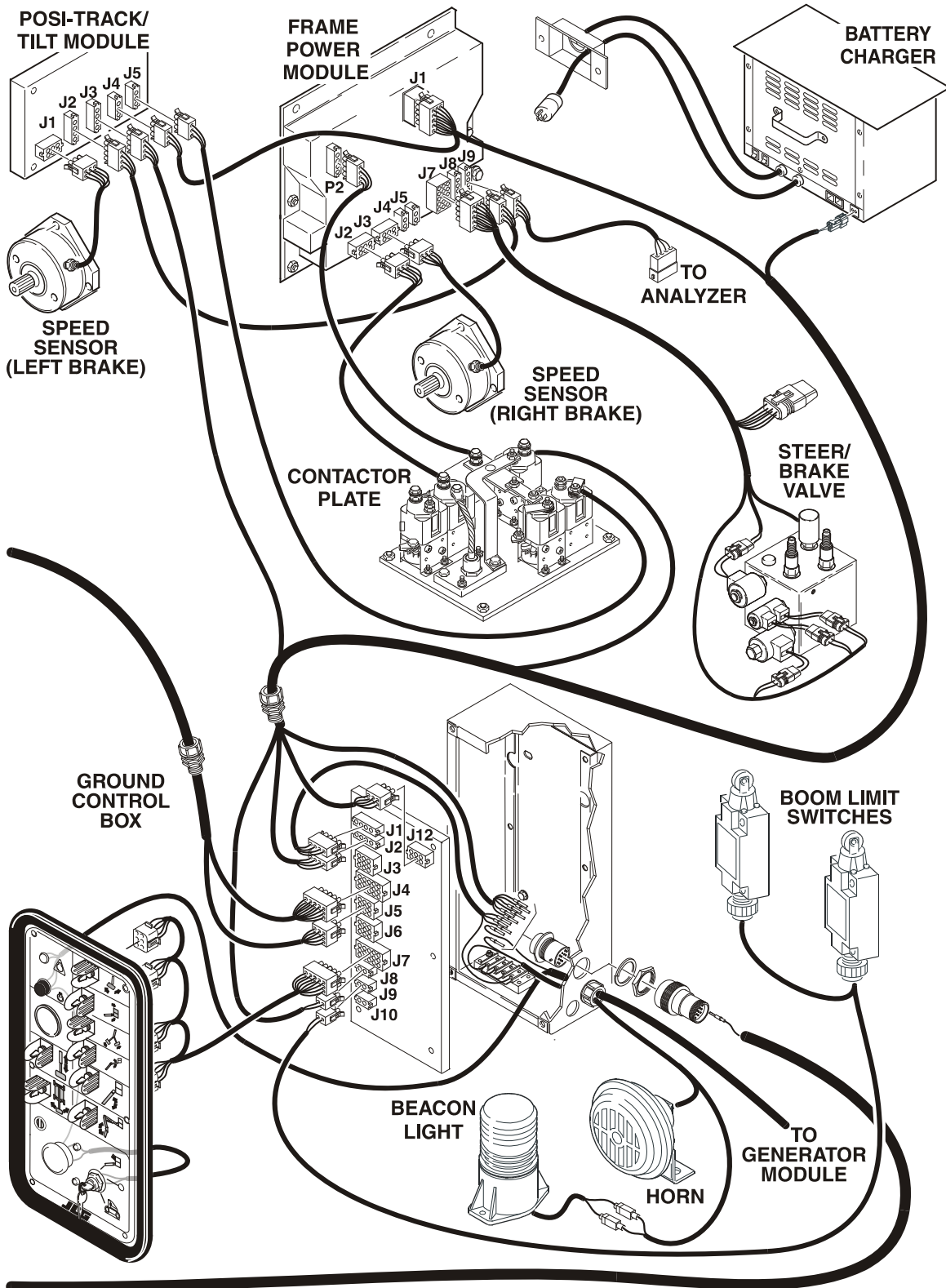

Figure 7-19. Electrical Components Installation - Sheet 2

SECTION 7 - BASIC TROUBLESHOOTING, ELECTRICAL INFORMATION, & SCHEMATICS

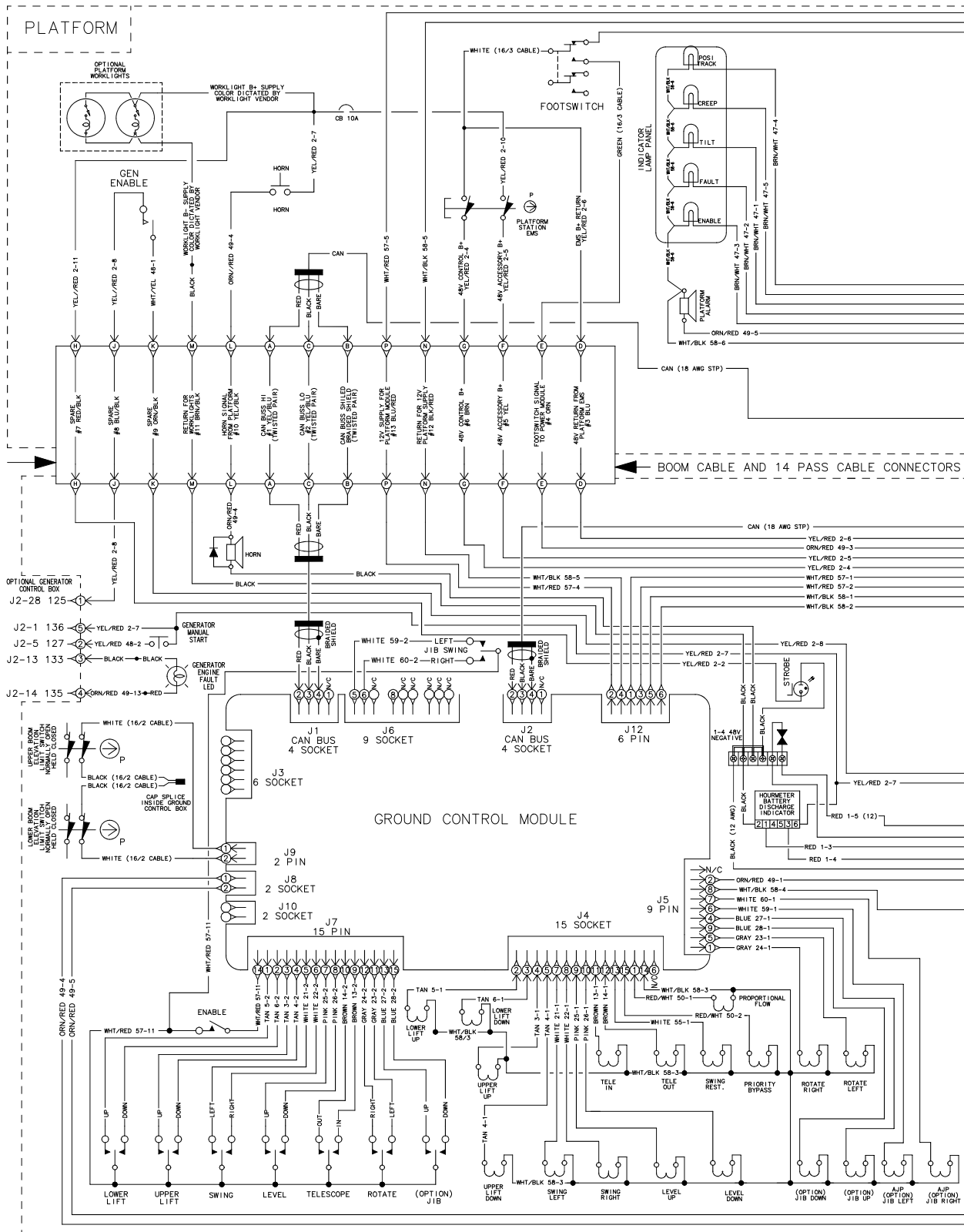

Figure 7-20. Electrical Schematic - Sheet 1 of 4

SECTION 7 - BASIC TROUBLESHOOTING, ELECTRICAL INFORMATION, & SCHEMATICS

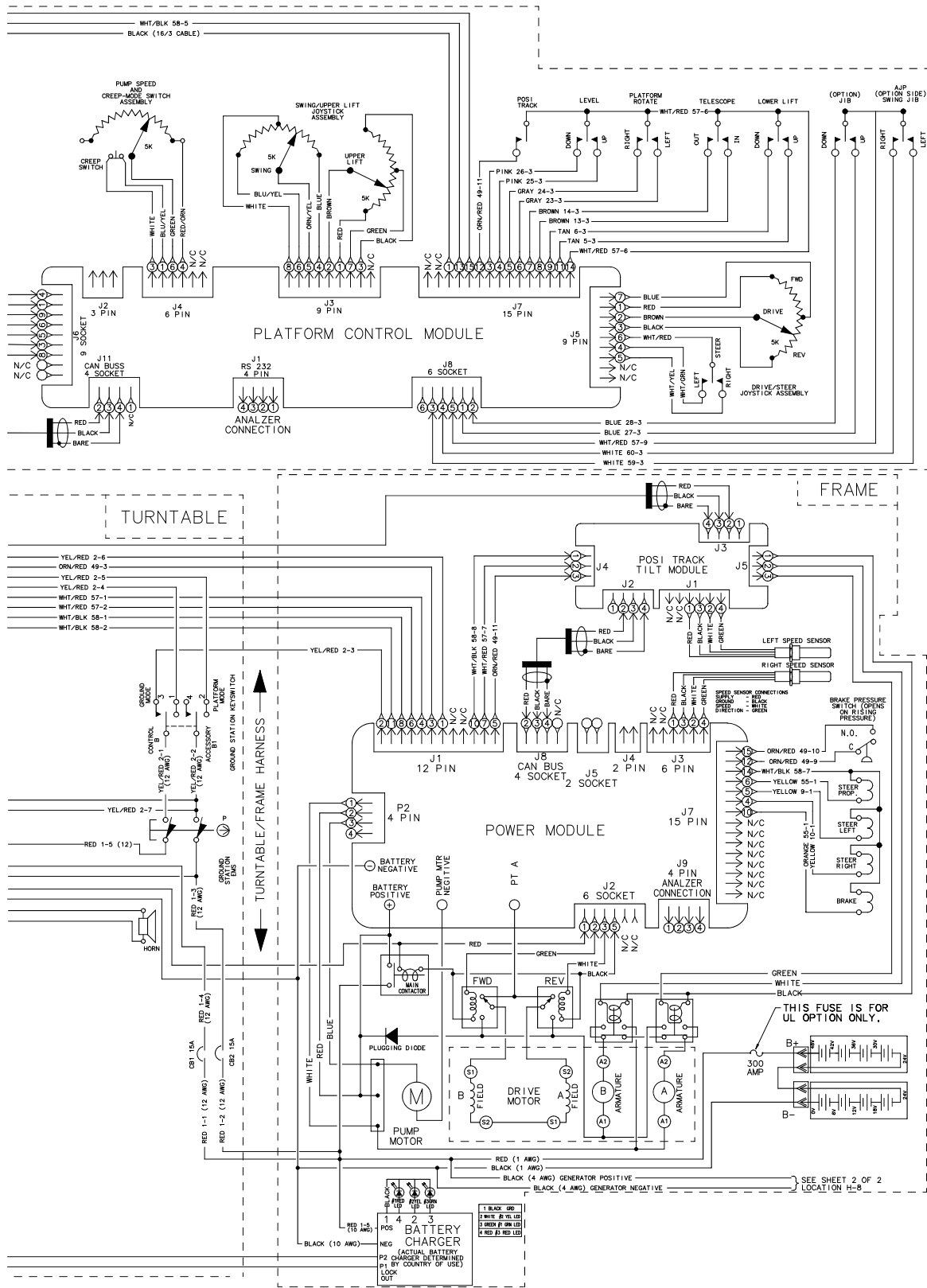

Figure 7-21. Electrical Schematic - Sheet 2 of 4

1870227 B

SECTION 7 - BASIC TROUBLESHOOTING, ELECTRICAL INFORMATION, & SCHEMATICS

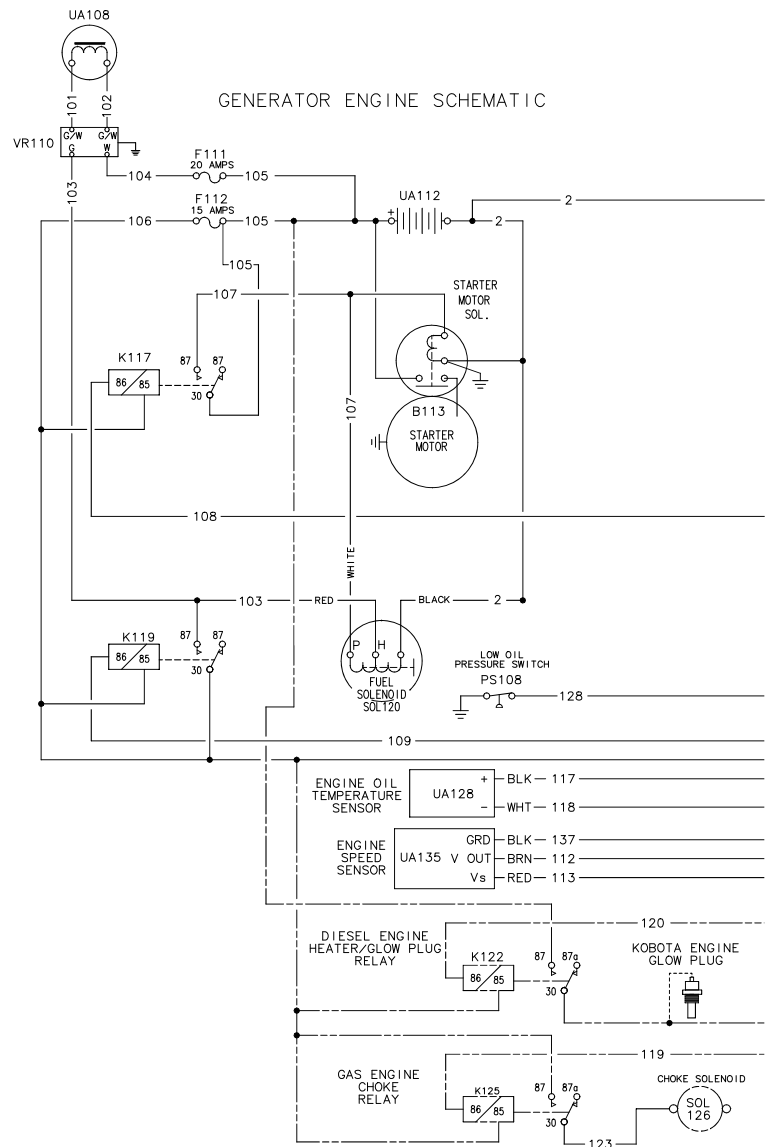
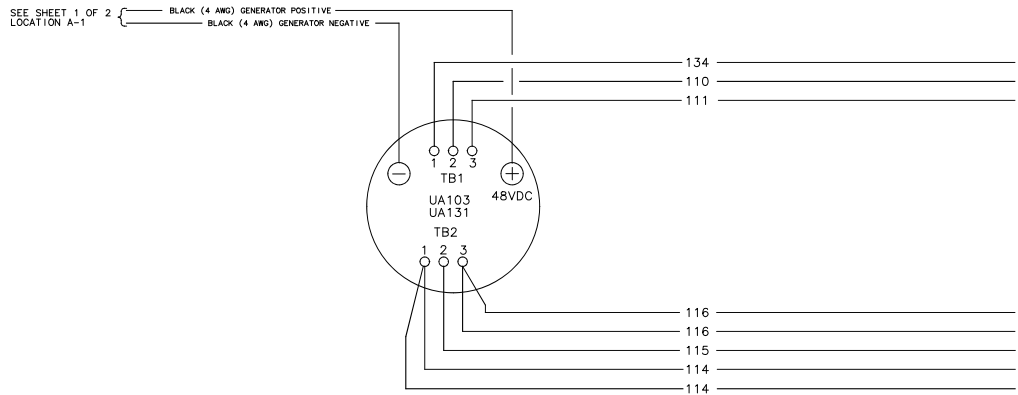
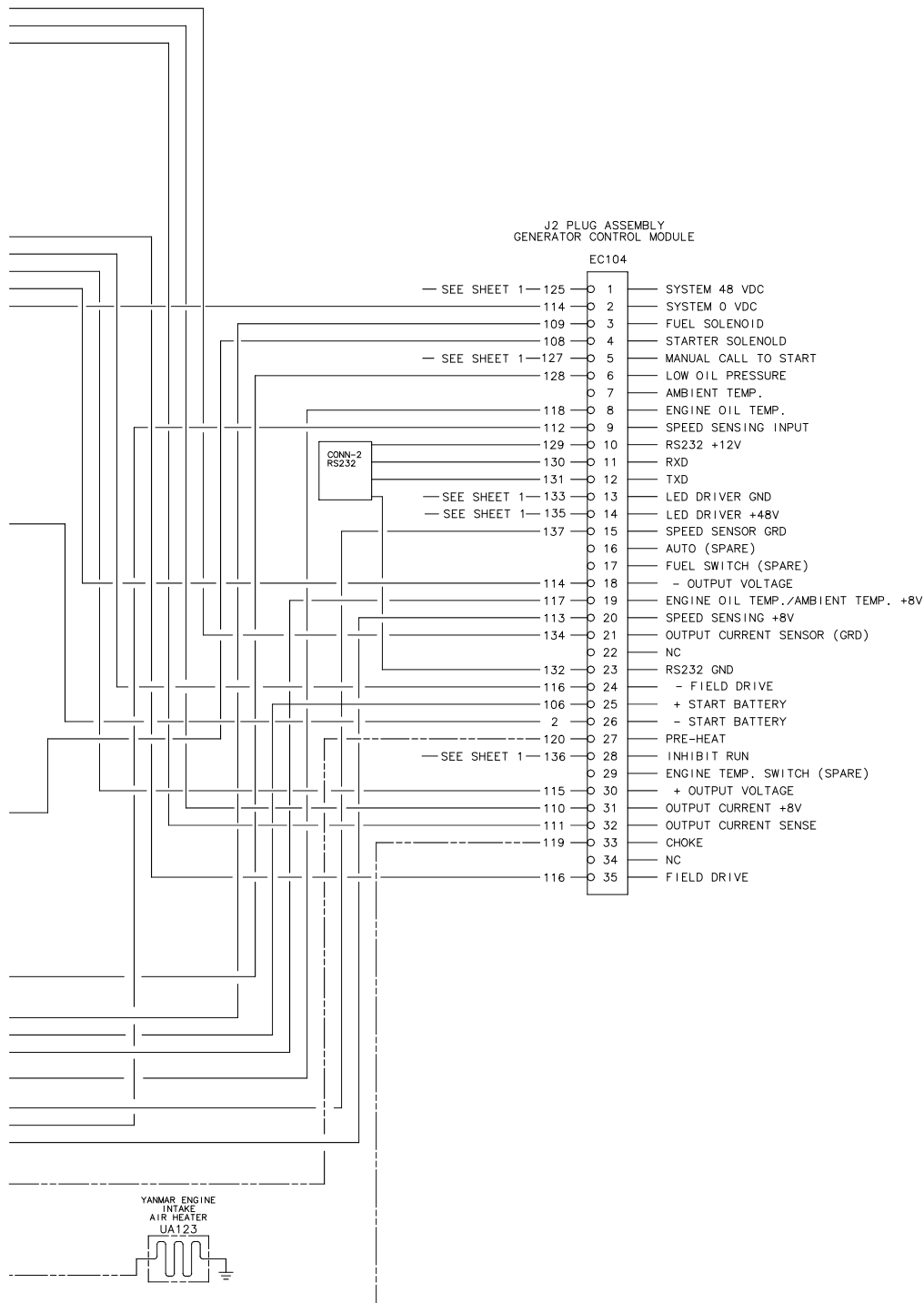

Figure 7-22. Electrical Schematic - Sheet 3 of 4

SECTION 7 - BASIC TROUBLESHOOTING, ELECTRICAL INFORMATION, & SCHEMATICS



1870227 B

Figure 7-23. Electrical Schematic - Sheet 4 of 4

SECTION 7 - BASIC TROUBLESHOOTING, ELECTRICAL INFORMATION, & SCHEMATICS

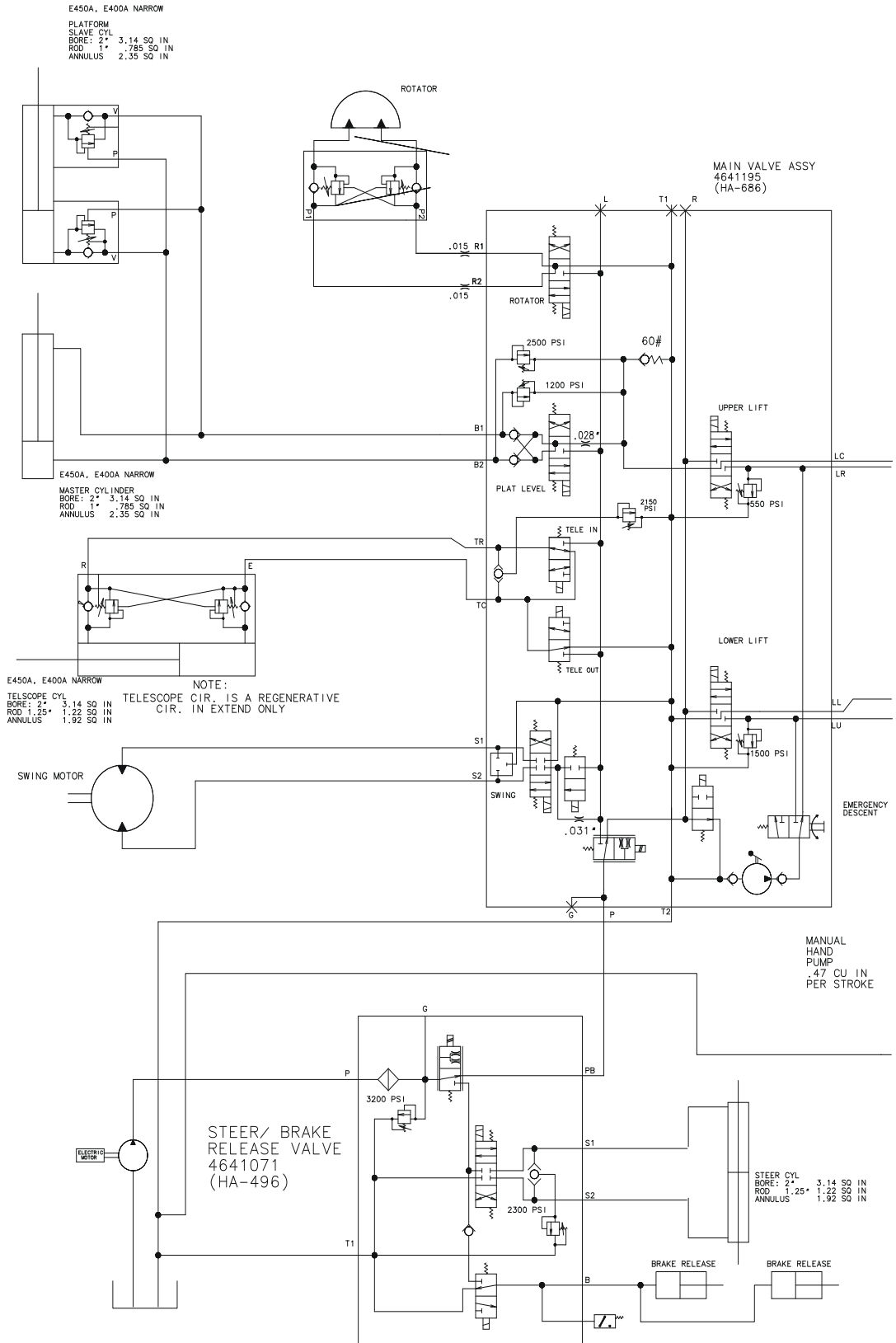
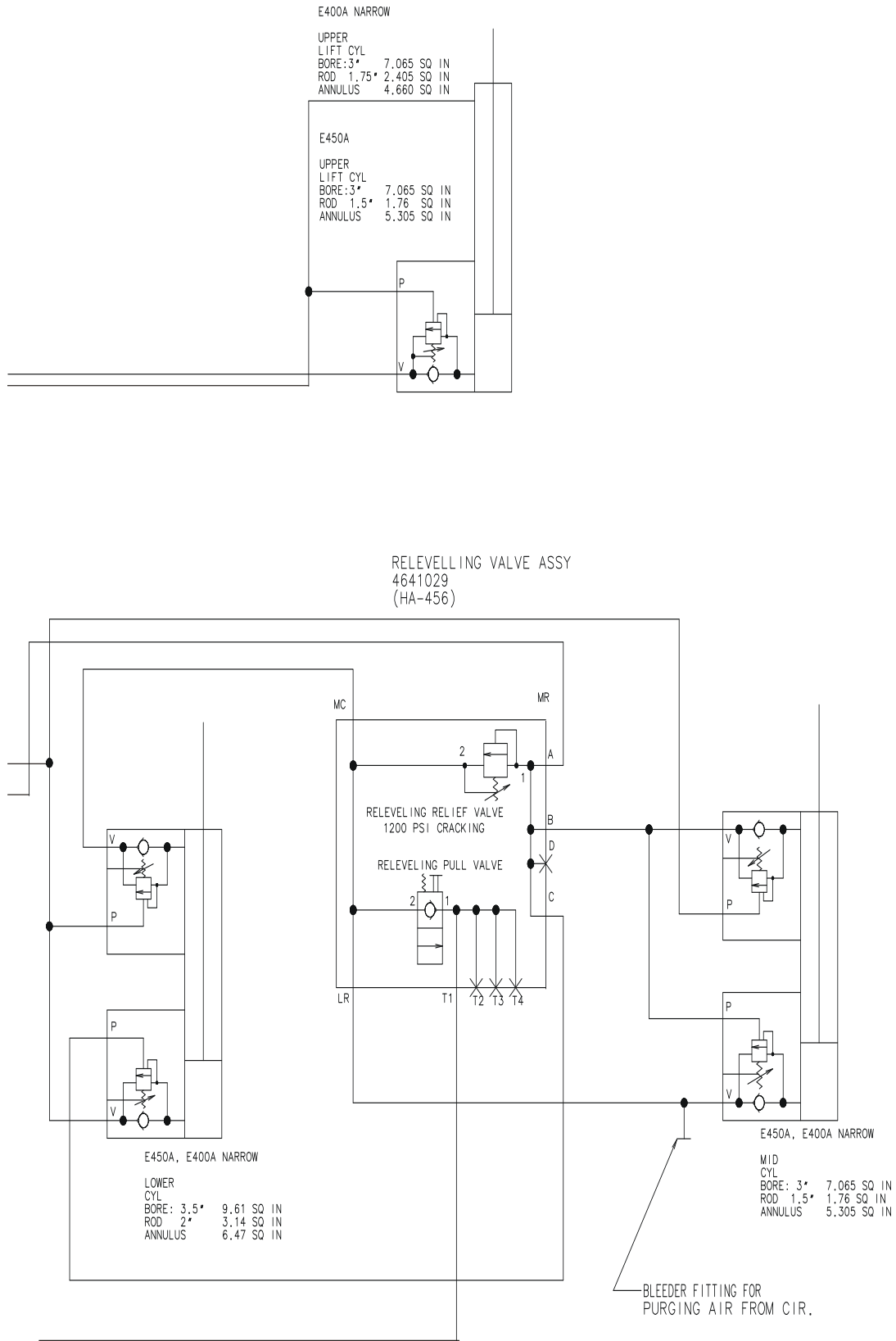

Figure 7-24. Hydraulic Schematic - M400A/E400A - Sheet 1 of 2

SECTION 7 - BASIC TROUBLESHOOTING, ELECTRICAL INFORMATION, & SCHEMATICS



2792505D

Figure 7-25. Hydraulic Schematic - M400A/E400A - Sheet 2 of 2

SECTION 7 - BASIC TROUBLESHOOTING, ELECTRICAL INFORMATION, & SCHEMATICS

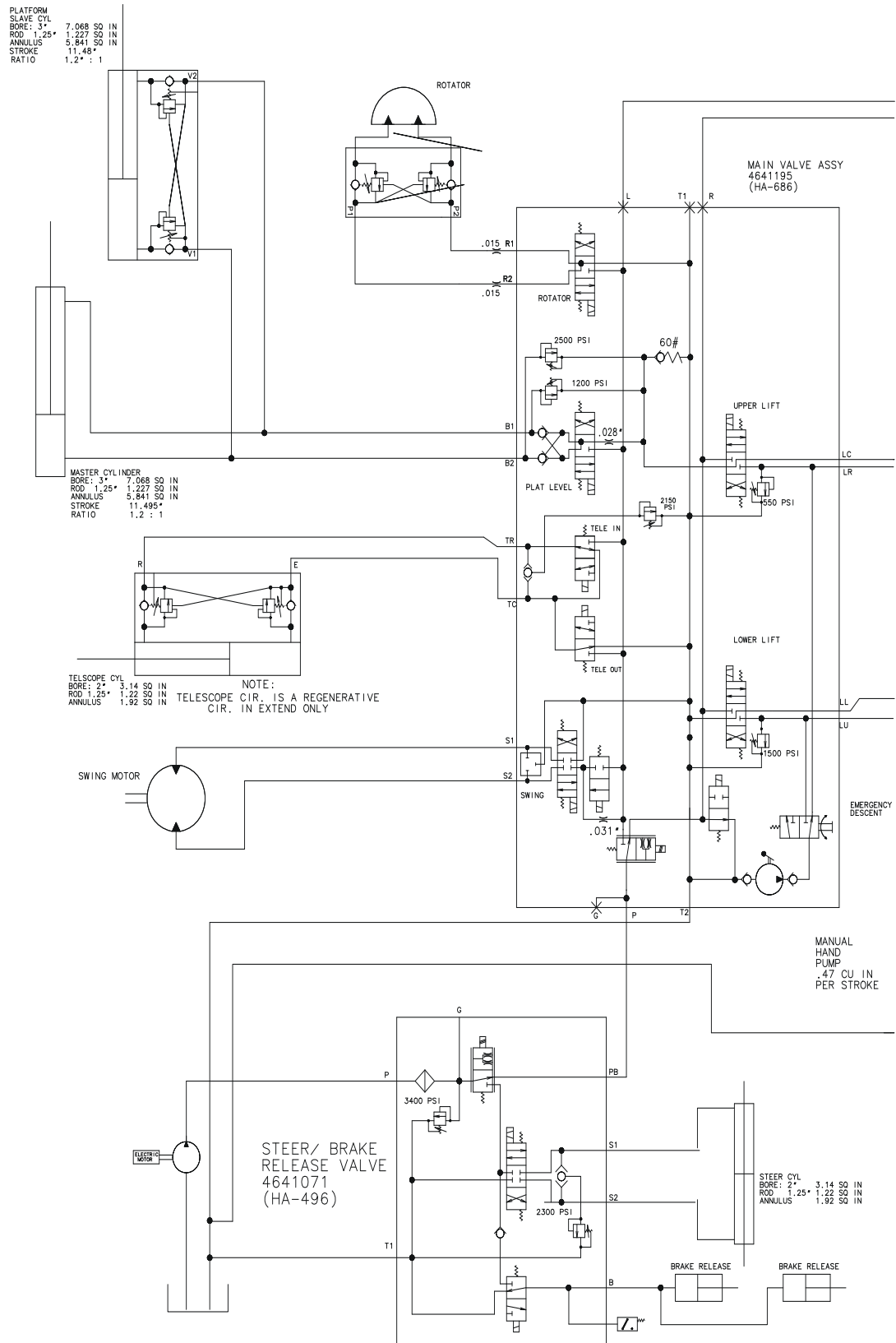
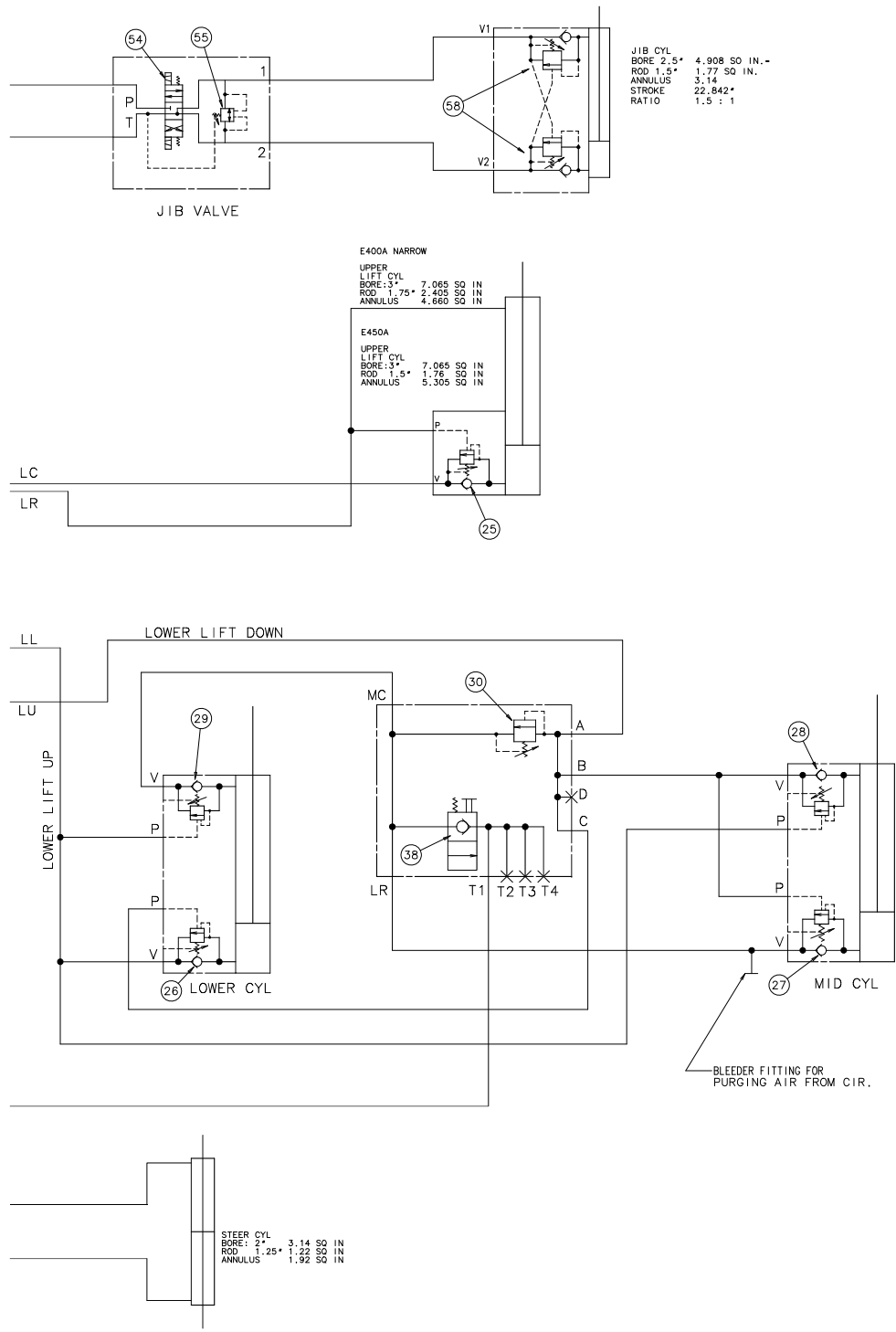

Figure 7-26. Hydraulic Schematic - M400AJ/E400AJ - Sheet 1 of 2

SECTION 7 - BASIC TROUBLESHOOTING, ELECTRICAL INFORMATION, & SCHEMATICS



2792505D

Figure 7-27. Hydraulic Schematic - M400AJ/E400AJ - Sheet 2 of 2

SECTION 7 - BASIC TROUBLESHOOTING, ELECTRICAL INFORMATION, & SCHEMATICS

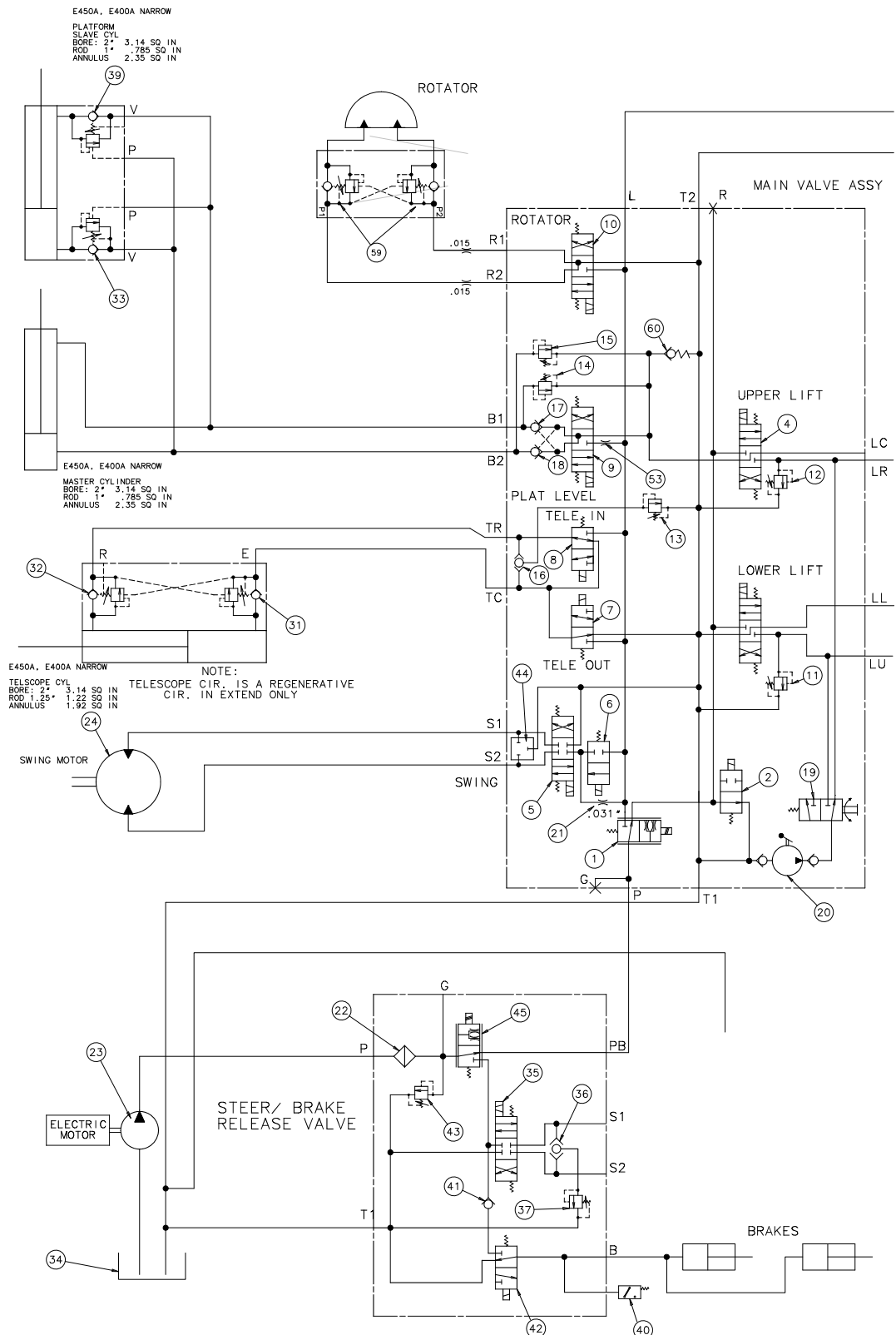
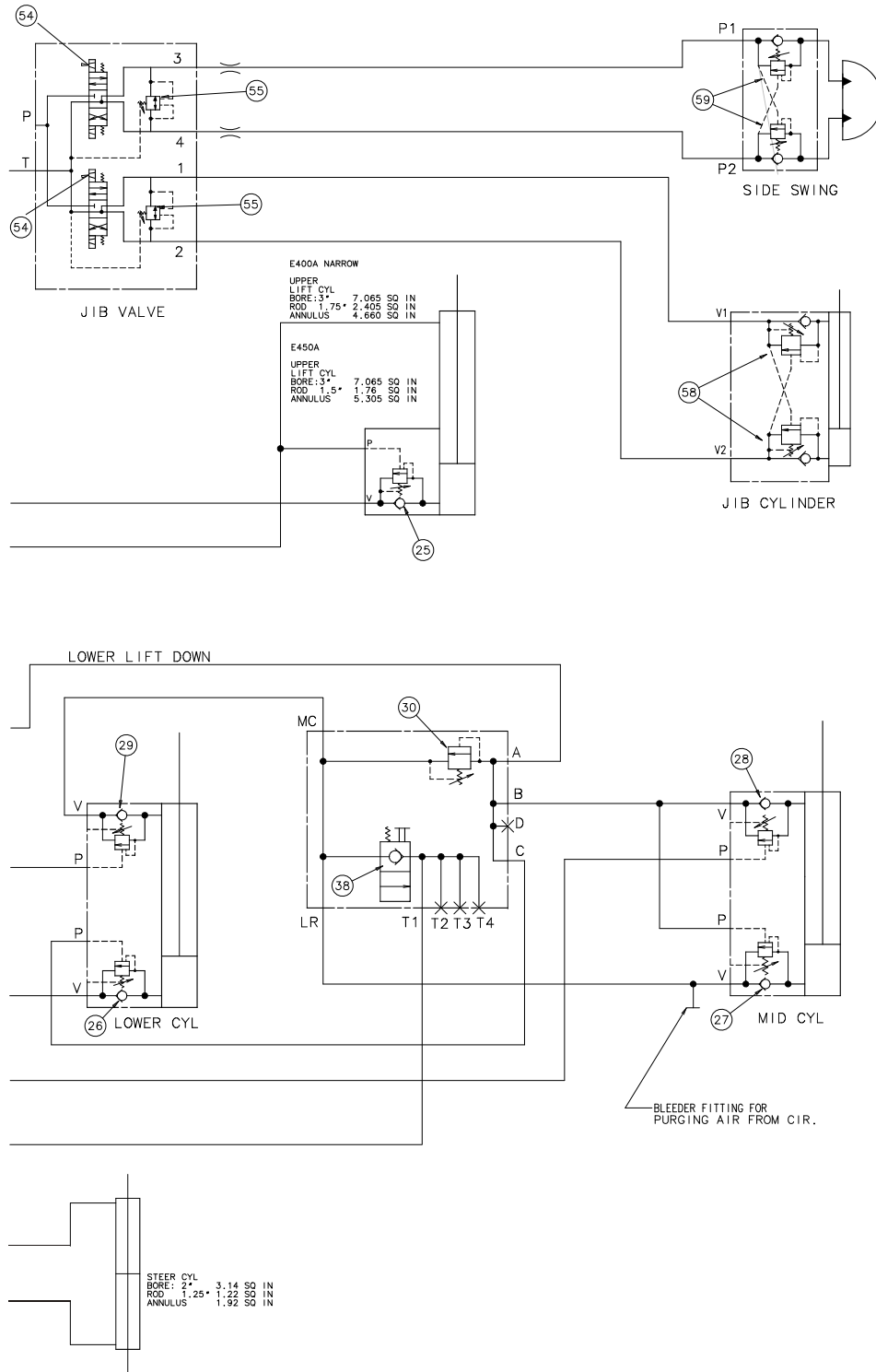

Figure 7-28. Hydraulic Schematic - M400AJ/E400AJ - Sheet 1 of 2

SECTION 7 - BASIC TROUBLESHOOTING, ELECTRICAL INFORMATION, & SCHEMATICS



2792505D

Figure 7-29. Hydraulic Schematic - M400AJP/E400AJP - Sheet 2 of 2

COMPONENT LIST

1. PROPORTIONAL FLOW REGULATOR, PRESSURE COMPENSATED.
2. 2-POS, 2-WAY POPPET VALVE, NORMALLY OPEN, (BYPASS UNLOADING)
3. 3-POS, 4-WAY VALVE, (LOWER LIFT)
4. 3-POS, 4-WAY VALVE, (UPPER LIFT)
5. 3-POS, 4-WAY VALVE, (SWING)
6. 2-POS, 2-WAY SPOOL VALVE, NORMALLY CLOSED
7. 2-POS, 3-WAY VALVE, (TELESCOPE OUT)
8. 2-POS, 3-WAY VALVE, (TELESCOPE IN)
9. 3-POS, 4-WAY VALVE, (PLATFORM LEVEL)
10. 3-POS, 4-WAY VALVE, (ROTATOR)
11. RELIEF VALVE, DIRECT ACTING, (LOWER LIFT DOWN) SET AT 2600 PSI
12. RELIEF VALVE, DIRECT ACTING, (UPPER LIFT DOWN) SET AT 800 PSI
13. RELIEF VALVE, DIRECT ACTING, (TELESCOPE) SET AT 3000 PSI
14. RELIEF VALVE, DIRECT ACTING, (PLATFORM LEVEL BACKWARD ROD END) SET AT 1200 PSI
15. RELIEF VALVE, DIRECT ACTING, (PLATFORM LEVEL FORWARD PISTON END) SET AT 3000 PSI
16. SHUTTLE VALVE, (TELESCOPE)
17. PILOT OPERATED CHECK, (PLATFORM LEVEL, ROD SIDE)
18. PILOT OPERATED CHECK, (PLATFORM LEVEL, PISTON SIDE)
19. ROTARY 2-POS, 3-WAY VALVE, (EMERGENCY DESCENT)
20. MANUAL HAND PUMP, (0.47 IN3)
21. 0.031" ORIFICE PLUG
22. FILTER, HIGH PRESSURE, 10 μ ABSOLUTE G1761
23. ELECTRIC MOTOR, PUMP ASSEMBLY, 48VDC
24. MOTOR, GEROTOR TYPE, FIXED 3.2 CU. IN., (SWING)
25. COUNTERBALANCE CARTRIDGE, 10:1 • 3000 PSI, NON-VENTED SPRING
26. COUNTERBALANCE CARTRIDGE, 1:1 • 3500 PSI, VENTED SPRING, SEALED PILOT
27. COUNTERBALANCE CARTRIDGE, 1:1 • 3500 PSI, VENTED SPRING, SEALED PILOT
28. COUNTERBALANCE CARTRIDGE, 5:1 • 4000 PSI, VENTED SPRING, SEALED PILOT
29. COUNTERBALANCE CARTRIDGE, 5:1 • 4000 PSI, VENTED SPRING, SEALED PILOT
30. RELIEF VALVE, DIRECT ACTING, (LEVELING RELIEF VALVE) SET AT 2200 PSI CRACKING PRESSURE
31. COUNTERBALANCE CARTRIDGE, 10:1 • 2500 PSI, NON-VENTED SPRING
32. COUNTERBALANCE CARTRIDGE, 5:1 • 2500 PSI, VENTED SPRING, SEALED PILOT
33. COUNTERBALANCE CARTRIDGE, PILOT RATIO: 7:1 (2500 PSI HOLDING, 3300 PSI THERMAL) NON-VENTED SPRING, SEALED PILOT
34. HYDRAULIC TANK
35. 3-POS, 4-WAY VALVE, (STEER)
36. SHUTTLE VALVE, (STEER)
37. RELIEF VALVE, DIRECT ACTING, (STEER) SET AT 1400 PSI
38. MANUAL, SPRING RETURN, PULL TO OPEN POPPET CARTRIDGE
39. COUNTERBALANCE CARTRIDGE, PILOT RATIO 10:1 (500 PSI HOLDING, 1200 PSI THERMAL) VENTED SPRING, SEALED PILOT
40. PRESSURE SWITCH
41. CHECK VALVE,
42. 3-WAY, 2-POSITION DIRECTIONAL POPPET VALVE,
43. RELIEF VALVE, DIRECT ACTING, (SYSTEM RELIEF) SET AT 3200 PSI
44. CARTRIDGE PLUG
45. PROPORTIONAL FLOW REGULATOR, PRESSURE COMPENSATED.
46. DELETED
47. DELETED
48. DELETED
49. DELETED
50. DELETED
51. DELETED
52. DELETED
53. 0.028 ORFICED PLUG
54. 3-POS, 4-WAY VALVE, (JIB)
55. RELIEF VALVE SET AT 1500 PSI
56. COUNTERBALANCE CARTRIDGE, 5:1 • 2500 PSI
57. COUNTERBALANCE CARTRIDGE, 10:1 • 700 PSI, 1200 PSI THERMAL
58. COUNTERBALANCE CARTRIDGE, 7:1 • 2500 PSI
59. COUNTERBALANCE CARTRIDGE, 3:1 • 3000 PSI, NON-VENTED SPRING
60. CHECK VALVE (SET AT 60 PSI)

Figure 7-30. Hydraulic Schematic Component List

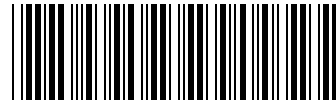

3121827



An Oshkosh Corporation Company

Corporate Office
 JLG Industries, Inc.
 1 JLG Drive
 McConnellsburg PA. 17233-9533
 USA

☎ (717) 485-5161

☎ (717) 485-6417

JLG Worldwide Locations

JLG Industries (Australia)
 P.O. Box 5119
 11 Bolwarra Road
 Port Macquarie
 N.S.W. 2444
 Australia
 ☎ +61 2 65 811111
 ☎ +61 2 65 813058

JLG Latino Americana Ltda.
 Rua Eng. Carlos Stevenson,
 80-Suite 71
 13092-310 Campinas-SP
 Brazil
 ☎ +55 19 3295 0407
 ☎ +55 19 3295 1025

JLG Industries (UK) Ltd
 Bentley House
 Bentley Avenue
 Middleton
 Greater Manchester
 M24 2GP - England
 ☎ +44 (0)161 654 1000
 ☎ +44 (0)161 654 1001

JLG France SAS
 Z.I. de Baulieu
 47400 Fauillet
 France
 ☎ +33 (0)5 53 88 31 70
 ☎ +33 (0)5 53 88 31 79

JLG Deutschland GmbH
 Max-Planck-Str. 21
 D - 27721 Ritterhude - Ihlpohl
 Germany
 ☎ +49 (0)421 69 350 20
 ☎ +49 (0)421 69 350 45

JLG Equipment Services Ltd.
 Rm 1107 Landmark North
 39 Lung Sum Avenue
 Sheung Shui N. T.
 Hong Kong
 ☎ (852) 2639 5783
 ☎ (852) 2639 5797

JLG Industries (Italia) s.r.l.
 Via Po. 22
 20010 Pregnana Milanese - MI
 Italy
 ☎ +39 029 359 5210
 ☎ +39 029 359 5845

JLG Europe B.V.
 Polaris Avenue 63
 2132 JH Hoofddorp
 The Netherlands
 ☎ +31 (0)23 565 5665
 ☎ +31 (0)23 557 2493

Plataformas Elevadoras
 JLG Iberica, S.L.
 Trapadella, 2
 P.I. Castellbisbal Sur
 08755 Castellbisbal, Barcelona
 Spain
 ☎ +34 93 772 4700
 ☎ +34 93 771 1762

JLG Sverige AB
 Enkopingsvagen 150
 Box 704
 SE - 176 27 Jarfalla
 Sweden
 ☎ +46 (0)850 659 500
 ☎ +46 (0)850 659 534