



ΜΗΧΑΝΗΜΑΤΑ ΑΥΛΑΚΩΣΗΣ

Grooving tool manual Model: GRINNELL-10A



1" - 8" / 25 - 200mm

GR-GRV10A-9/2001

Mechanical



SAFETY FIRST!

Carefully read and understand this manual before operating the Grinnell-10A grooving tool.

INTRODUCTION

The Grinnell-10A grooving machine is a semi-automatic, hydraulically operated machine. The machine is equipped for roll grooving of steel pipe with a diameter between 25 and 200 mm (1" - 8") and a maximum wall thickness of 8 mm. Pipe grooved with the Grinnell-10A grooving machine, and in accordance with the specifications as mentioned in this manual, is then suitable for Grinnell grooved type couplings.

The Grinnell-10A grooving machine is designed to groove steel or stainless steel pipe, so the pipe can be fitted with Grinnell couplings and fittings. Do NOT use it for other purposes. This machine is equipped with a number of safety features. Do not remove these features:

- Protective cover (Fig 01)
- Foot switch (Fig 02)
- Shaft cover (Fig 03)
- Main switch (Fig 04)

When removed for servicing or repairs, always replace these safety features before operating the machine. Always disconnect the power-supply before performing maintenance or service on the Grinnell-10A.

Warning! Disabling the safety features on the Grinnell-10A will result in hazardous situations. Never operate the machine without these safety features!

Following points should be noted before operating the Grinnell-10A grooving machine:

GENERAL WARNING!

Although everything possible has been done to make the Grinnell-10A as safe and user-friendly as possible, certain areas of potential operator-hazard remain.

Never attempt to reach into the top- and bottom roll area whilst grooving or whilst the rolls are rotating when the Grinnell-10A is in operation.

Never remove the protective cover for ease of operation (see Fig 01).

Never remove the protective cover on the engine whilst the power is switched ON or whilst the power is still connected.

Never perform maintenance or repairs with machine switched on.



Fig 01: Protective cover.



Fig 02: Foot Switch.



Fig 03: Shaft Cover.



Fig 04: Main Switch.



1. Inspect the grooving machine before operating it. Check whether all parts, protective covers and other safeties are in place, and mounted as described in this manual.
Checklist:
 - 4 legs
 - Tap out pin for removal of lower roll
 - Depth gauge
 - Lower roll 1"
 - Lower roll 1¼" – 1½"
 - Lower roll 2" - 6"
 - Lower roll 8"
 - Allen Key (4mm)
 - Allen Key (5mm)
 - Allen Key (10mm)

2. Make sure the machine is switched "OFF" before plugging in the unit. Always use the foot-switch for operation.
3. Check the electric engine for exact power requirements. The Grinnell-10A comes with a 220V engine as a standard, but can be supplied with different voltages. Make sure a proper connection is made by a qualified electrical engineer. Check if the machine is connected to an internally grounded electrical system. Do NOT operate the machine in a damp or wet environment.
4. Make sure that the machine is bolted down and fixed to the floor so that it can not be moved while operating the machine, and is able to help support the weight of the pipe.
Warning! If the machine is not bolted down or fixed to the floor, it will cause a hazardous situation, since the pipe may come loose of the machine during operation!
5. Pipe should be supported by a proper pipe-support. See page 4 for details. Pipe diameters exceeding 4"/100mm should be supported with the side roll (See Fig 05). Do not attempt to groove pieces of pipe with a length shorter than 200 mm (8").
Warning! Grooving pipe shorter than 200 mm will cause a hazardous situation and can cause operational hazards.
6. When servicing the machine, or when changing roll sets, always switch off the machine and disconnect the power cord.
7. Regularly service the machine and maintain it as described in this manual, see page 8 and 9.
8. Do not attempt to groove pipe with a diameter of over 8"/200 mm or with a wall thickness exceeding 8 mm.
Warning! Grooving pipe exceeding wall thickness of 8mm will cause a hazardous situation and can cause operational hazards.
9. Make sure that clothing, gloves etc. stay well clear of the rotating rolls when in operation at a minimum distance of 15 cm.
10. Do not operate the machine when not fully aware of its proper functioning, or when feeling unable to operate the machine.
11. Wear protective gloves and shoes at all time, when operating the machine.
12. Make sure that the operating area is suited for the purpose. It should have proper illuminations, be tidy and clean, and should not cause any hindrance when operating the machine.
13. Only authorized and skilled personnel should operate the machine.

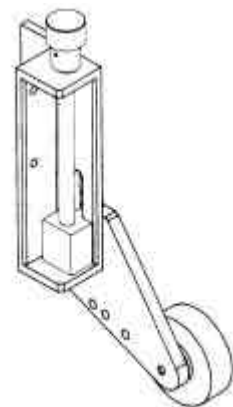

Fig 05: Side Roll.

SET UP OF A NEW TOOL



When shipped in a crate, first check whether all components are in place as described on the packing list.

Checklist:

- 4 legs
- Tap out pin for removal of lower roll
- Depth gauge
- Lower roll 1"
- Lower roll 1¼ " - 1½ "
- Lower roll 2" - 6"
- Lower roll 8"
- Top roll 1" - 6"
- Top roll 8"
- Allen key (4 mm)
- Allen key (5mm)
- Allen key (10 mm)
- Safety covers
- Side roll
- Measuring tape



Fig 06: Arrow on Shaft Cover.

For ease of handling, the Grinnell-10A has a hoist point on the back of the machine, see drawing on page 12. The total weight of the Grinnell-10A is approximately 100 Kg. Only lift the machine with a hoist on this point.

Warning! Make sure the machine is fastened properly. Failure to do so may cause the machine to drop from the hoist and cause hazardous situations for the operators. At no time place yourself under the machine! Place the 4 legs under the grooving-table and secure them in place. Make sure the bolts are properly tightened (use a torque wrench to reach 85Nm) and check whether the legs are fixed in position.

Check the local power supply, and compare that with the machine you have just received. Connect the correct power plug to the cable, and make sure it is suitable for the connection on site. When connected properly, if switched on, the lower shaft and roll should rotate counter-clockwise (see the arrow on the shaft cover showing the direction of rotation (Fig 06)).

Warning! All electric connections must be done by a qualified electrical engineer. Check whether the proper roll set is mounted on the machine. If not, do not attempt to groove a different pipe-size with a non-corresponding roll set. When needed, change the roll set according to the steps as described in this manual.

Secure the Grinnell-10A grooving machine to the floor, making sure it is placed level.

Warning! An unstable machine is a potential hazard. It may cause the pipe to drop-off the lower roll while grooving!

SOUND PRESSURE LEVEL

During tests it was established that, when recorded at 1.5 meter height and at a distance of 0.5 meter from the machine, the Grinnell-10A produces less than 75 dB(A) sound pressure level. This area can be compared to the place where the operator will normally be positioned. Depending on local rules, ear protection may or may not be needed.

PIPE DETAILS

Make sure that pipe ends are square cut. Weld bead or seams (in- and outside) must be ground flush with the pipe surface over a distance of 50 mm. Any dirt, scale, debris or other



foreign matter should be removed from the pipe ends since this may interfere with proper tool operation.

PIPE SUPPORT

Any pipe-length exceeding 1.5 m (or shorter if so required) must be supported by a proper pipe support. It will prove necessary that large diameter pipe is supported even when working with shorter lengths. Any pipe length under 200 mm should not be grooved since this may cause danger to the operator of the grooving machine. When in doubt, contact your dealer or your nearest Grinnell Sales & Distribution office. The pipe-support must be placed just beyond one-half of the pipe length from the tool. Pipe should be level with the tool, or at a maximum of $\frac{1}{2}^\circ$ below level.

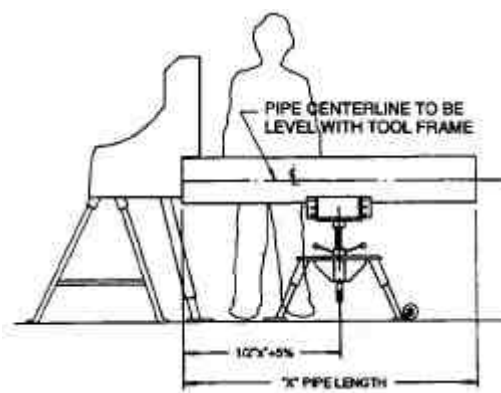

The pipe support should be moved at around $\frac{1}{2}^\circ$ to the right, when facing the tool. When placed like this, the pipe will track properly and will be held against the back-flange of the lower roll.

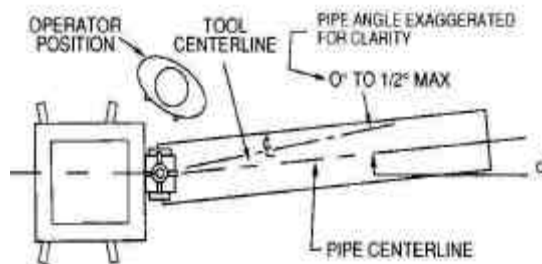

Should the pipe-end start flaring (increasing outside diameter) whilst grooving, the angle that is used is too big, and should be reduced (either the angle towards the machine or towards the horizontal position). Pipes exceeding the outside diameter of 4"/100mm must be supported with the side roll. This prevents the pipe for jumps and thumps during the grooving process.

Also check the section "Trouble Shooting" page 10 of this manual.

GROOVING OPERATIONS

Checklist before operating

- Check power connection
- Check main switch
- Check safety (clothing, gloves, shoes)
- Check the safety features on the Grinnell-10A
- Check the stability of the machine (bolted to the floor)
- Check the roll set for proper sizing
- Check whether the pipe-preparation is satisfactory

Check whether the protective cover is in place. Always wear safety-shoes and gloves when operating the Grinnell-10A. Beware of loose clothing, ties, scarves etc.

After having checked whether the correct roll-set is in place, make sure the main switch (Fig 07) is in the OFF position. The machine can now be connected to the proper power supply. Make sure the machine is fixed to the floor and grooving can commence.

Always use gloves and safety footwear when operating the Grinnell-10A.



Fig 07: Main Switch.



Fig 08: Hydraulic Hand Pump.



Open the valve on the hydraulic hand pump. The upper-roll block will now come up. Rotate and raise the adjustable stop and locking nut into top position. Now close the valve on the hydraulic hand-pump (Fig 08). Make sure that the upper- and lower rolls are properly aligned. If not aligned, the roll-set may be damaged. Check whether the proper roll set is mounted.

Lay the pipe over the lower roll, against the back flange (Fig 09). By operating the hand pump, lower the upper-roll until it is in contact with the pipe (Fig 10).



Fig 09: Lay pipe over roll.

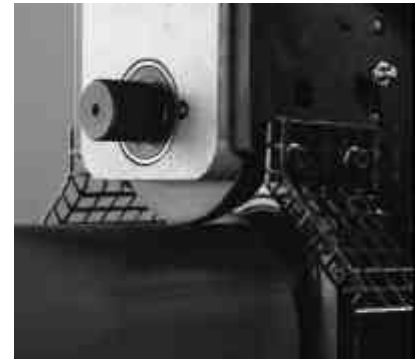

Fig 10: Lower upper roll

Place the depth-gauge under the depth-adjuster (Fig 11) and lower the depth-adjuster until it is in contact with the corresponding pipe size on the gauge (Fig 12). Secure and lock the depth-adjuster in place **and remove the gauge**.



Fig 11: Depth Adjuster.



Fig 12: Depth Gauge.

Put the main switch at the back in the ON position.

Check whether the pipe is properly placed on a pipe support, or firmly hold the pipe as shown.

Always use gloves when operating a Grinnell grooving machine.

Start the machine with the foot switch (Fig 13). The pipe will now rotate. Make sure that hands, gloves, loose clothing etc. stay well clear. Do **NOT** attempt to reach into the area of the top- and bottom roll.



Fig 13: Foot Switch.



Fig 14: Hand Pump.

Keep hands and fingers well clear of the top- and bottom roll area. Never remove the Safety-cover and never try to reach inside the Safety-cover while grooving.

Whilst the pipe is rotating, apply more pressure by operating the hydraulic pump (Fig 14). Apply pressure evenly and let the pipe make a full rotation after every stroke of the hydraulic hand pump. Make sure that the pipe stays in full contact with the back-flange. Groove to full depth as allowed by the adjustable stop. When this point is reached, stop applying pressure and release the footswitch.

Open the valve on the hydraulic pump (Fig 08), the upper block and top roll will now be released from the pipe.



Warning! Be careful, unsupported pipe will drop off the lower roll and can create a hazardous situation.

Now remove the pipe. Carefully check and measure the groove diameter. If the groove diameter is too big (groove too shallow) raise the adjustable depth stop. By lowering the adjustable depth stop, the groove diameter decreases (groove less deep). On the depth-stop, each point is 0.1 mm. When needed, re-groove another piece of pipe, until the proper dimensions are obtained.

When the correct groove diameter is reached, grooving can continue for that size (and wall thickness) without adjusting the grooving machine. However, periodically recheck the grooves and take proper action when needed.



Fig 15: Measure the groove.

During grooving, check the Grinnell-10A for proper operation. Check whether a possible pipe support is properly positioned, and inspect the grooving area for possible loose pieces of pipe that may cause an obstruction.

CHANGING ROLL-SETS

SAFETY FIRST

Warning! Before changing a roll on the machine, or before any other handling or maintenance is done, make sure that the power is disconnected and the main switch is in the OFF position.

Check the roll-set mounted on the grooving machine. If incorrect, the roll set must be changed to groove the pipe size needed.

With each machine, a set of tools is supplied, needed to change rolls. This set consists of an Allen-key 4mm (for the top-roll), an Allen-key 5mm (for the protection cover), an Allen-key 10mm (for the legs) and a tap-out pin (Fig 16).



Fig 16: Set of Tools. !!!!!!!!!!!

Remove the locking pin from the lower shaft by tapping it out with the pin and using a hammer (Fig 17).



Fig 17: Remove locking pin.

Pull the lower roll out of the lower shaft (Fig 18).



Fig 18: Remove lower roll.

Loosen the Allen- or hexagon screw in the top roll by using the 4mm Allen key (Fig 19).



Fig 19: Loosen the top roll.

Loosen the upper shaft from behind by carefully tapping it with the pin and a hammer (Fig 20).



Whilst holding the top roll, pull out the upper shaft. If the top roll is not supported it will fall out the upper block. Now remove the top roll (Fig 21).

Check whether the upper and lower roll matches in size. Clean all parts and lubricate the upper and lower shaft. Use a standard lubricant. Now, with the text on the front side, place the top roll into position. Insert the upper shaft through the top roll (Fig 22).



Fig 20: Loosen the upper shaft.



Fig 21: Pull out the upper shaft.

Check the exact location on the shaft and tighten the Allen screw in the shaft using the 4mm Allen key. Properly fasten the screws to secure the upper roll (Fig 19).

Place the bottom roll in the lower shaft with the marking "X" on the bottom roll placed opposite the mark "X" on the lower shaft (Fig 23).



Fig 22: Check rolls.



Fig 23: 'X' marks.

Place the locking pin in the lower shaft from the side where the mark "X" stands. Check whether all marks are in the right position before operating the machine. Secure the locking pin by tapping it lightly with a hammer (Fig 24). Make sure the locking pin is below the surface of the lower roll. When the locking pin is above the level of the lower roll, this will cause operational problems, but also means that the lower roll is not secured, or improperly installed. Check and re-install if needed.



Fig 24: Locking Pin.



Fig 25: Lubricating Points.

Warning! An unsecured lower roll may cause a dangerous situation with operator hazard.

MAINTENANCE AND MACHINE ADJUSTMENT

SAFETY FIRST

Before doing any maintenance or service, or before any other handling is done, make sure that the power is disconnected and the main switch is in the OFF position.

At regular intervals, service the lubricating points on the grooving machine (Fig 25). Also, lubricate the drive chain with lightweight grease every 100 hours and before any lengthy storage. Any commercial/industrial lubricant can be used.



Disconnect power supply by putting the main switch in the OFF position. Do not do any maintenance on the machine with the power connected and switched on, unless otherwise specified.

Should the hydraulic pressure be insufficient, remove the filler plug and check the oil level. The level should be above the plunger, which can be seen when the filler plug is removed.

If needed, refill with hydraulic oil only. Hydraulic oil with a visco-index of 100° and an ISO Vg of 68 are suitable for this (e.g. Shell Telkus 68 or Esso Terreso 68).

If the oil level is sufficient, increase the hydraulic pressure. This can be done by removing the filler plug and inserting a screwdriver into the hydraulic container. By turning the set screw the pressure can be increased or decreased. Normal factory setting of hydraulic power however, should enable you to groove pipe with a maximum wall thickness.

When needed, always order original spare parts from your supplier. Do not use other than original parts. If in doubt, contact Grinnell. For proper and adequate repairs, always contact Grinnell for instruction. Do not attempt to alter or adjust the machine without consulting Grinnell.

GENERAL REMARK

Grinnell reserves the right to change any product or product specification, design and standard equipment without notice and without incurring obligation.



Fig 26: Filler plug oil reservoir.



Fig 27: Adjust oil pressure.



CHRYSSAFIDIS

TROUBLESHOOTING

<ul style="list-style-type: none"> • Pipe runs of the lower roll 	<ul style="list-style-type: none"> • Wrong positioning • Wrong technique 	<ul style="list-style-type: none"> • See page 5 • See page 6
<ul style="list-style-type: none"> • Pipe doesn't turn while grooving 	<ul style="list-style-type: none"> • Smooth rolls • Locking pin is missing • Paint or dirt on bottom roll 	<ul style="list-style-type: none"> • Replace rolls • Replace locking pin • Clean bottom roll
<ul style="list-style-type: none"> • Pipe jumps and thumps while grooving 	<ul style="list-style-type: none"> • Excessive weld seam • Incorrect support 	<ul style="list-style-type: none"> • Grid and remove in and outside over a distance of 50mm. • Install Side Support
<ul style="list-style-type: none"> • While grooving pipe squeaks 	<ul style="list-style-type: none"> • Over-tracking of the pipe • Pipe is 'soft' and has excessive contact with lower roll flange • Pipe is not square cut 	<ul style="list-style-type: none"> • Reposition pipe • Grease the back flange of the lower roll • Cut pipe square
<ul style="list-style-type: none"> • Excessive flare on pipe 	<ul style="list-style-type: none"> • Pipe support incorrect • Pipe support too high • Machine is tilted • Over-tracking of the pipe 	<ul style="list-style-type: none"> • See page 5 • See page 5 • See page 5 • Move support to the left
<ul style="list-style-type: none"> • Pipe can not be grooved 	<ul style="list-style-type: none"> • Excessive pipe hardness • Low hydraulic oil • Low hydraulic pressure • Pipe wall thickness 	<ul style="list-style-type: none"> • Check with supplier • See page 9 • See page 9 • Pipe wall thickness exceeding 8.0mm



ROLL GROOVE DIMENSIONS

Pipe Size mm	Pipe Outside Diameter		Gasket seat width A ± 0.8mm	Groove width B ± 0.8mm	Groove Diameter C mm		Groove depth D (ref. only) mm	Minimum allowable wall thickness T mm	Maximum flare diameter mm	
	Nominal mm	Tolerance			Actual mm	Toler. +0.000				
		+								-
25	33.7	0.4	0.7	15.9	7.1	30.2	-0.38	1.7	1.8	36.3
32	42.4	0.5	0.6	15.9	7.1	39.0	-0.39	1.7	1.8	45.0
40	48.3	0.5	0.5	15.9	7.1	45.1	-0.38	1.6	1.8	51.1
50	60.3	0.6	0.6	15.9	8.7	57.2	-0.38	1.6	1.8	63.0
65	73.0	0.7	0.7	15.9	8.7	69.1	-0.46	2.0	2.3	75.7
65	76.1	0.8	0.8	15.9	8.7	72.3	-0.46	1.9	2.3	78.7
80	88.9	0.9	0.8	15.9	8.7	84.9	-0.46	2.0	2.3	91.4
100	108.0	1.1	0.8	15.9	8.7	103.7	-0.51	2.1	2.3	110.5
100	114.3	1.1	0.8	15.9	8.7	110.1	-0.51	2.1	2.3	116.8
125	133.0	1.3	0.8	15.9	8.7	129.1	-0.51	2.1	2.9	135.9
125	139.7	1.4	0.8	15.9	8.7	135.5	-0.56	2.1	2.9	142.2
125	141.3	1.4	0.8	15.9	8.7	137.0	-0.56	2.1	2.9	143.8
150	159.0	1.6	0.8	15.9	8.7	154.5	-0.56	2.2	2.9	161.3
150	165.1	1.6	0.8	15.9	8.7	160.9	-0.56	2.2	2.9	167.6
150	168.3	1.6	0.8	15.9	8.7	164.0	-0.56	2.2	2.9	170.9
200	219.1	1.6	0.8	19.0	11.9	214.4	-0.64	2.3	2.9	223.5

- Out of roundness: Difference between maximum OD and minimum OD measured at 90° must not exceed total OD tolerance listed.
- Gasket seat and groove must be free from scores, seams, chips, rust or scale which may interfere with proper coupling assembly.

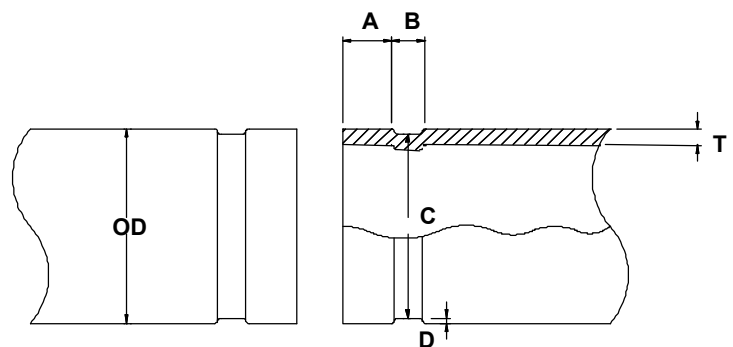



CHRYSSAFIDIS

INSTRUCTIONS FOR MOUNTING SIDE SUPPORT ON GRINNELL-10A GROOVING MACHINE.

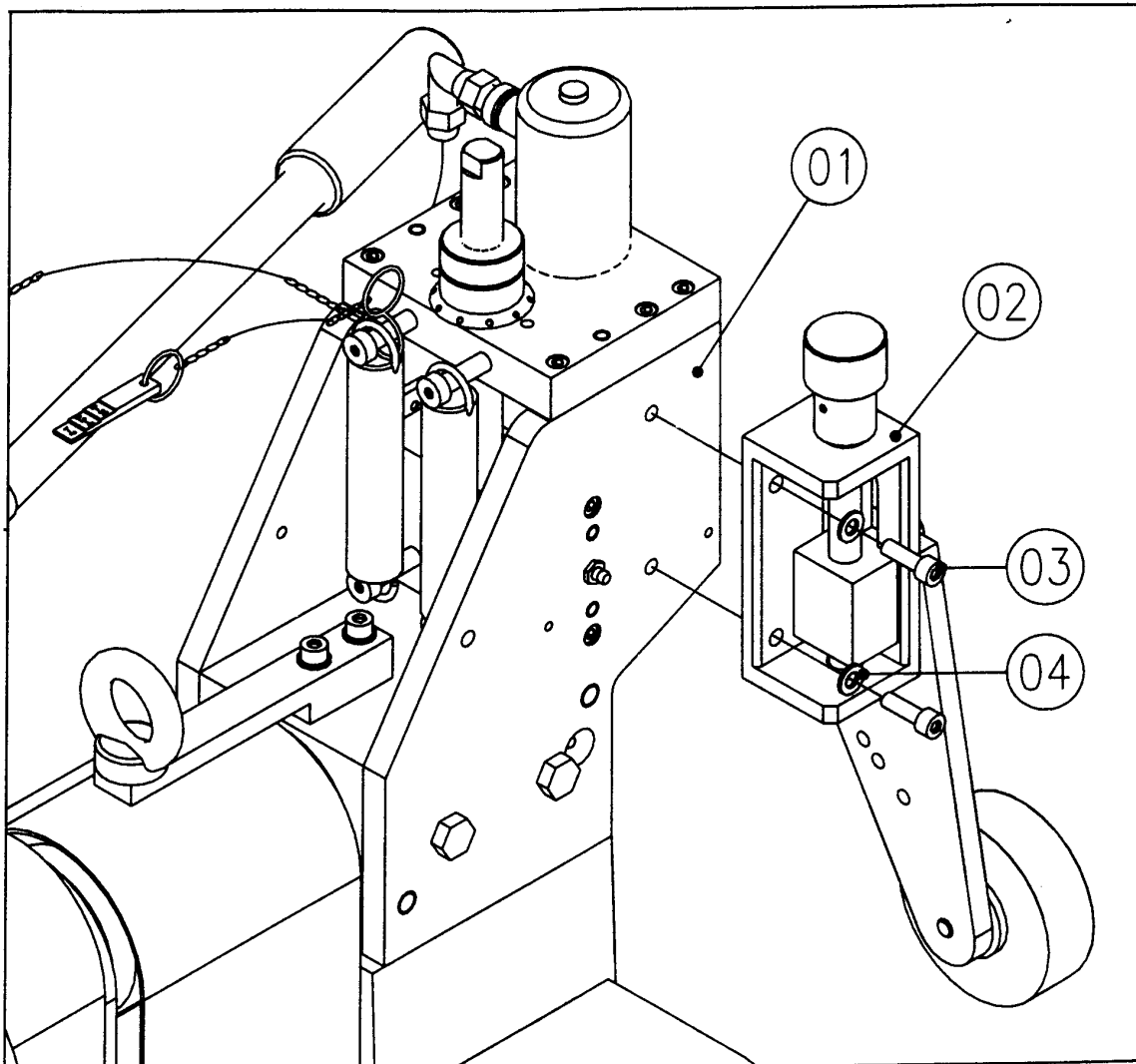

Mounting side support:

1. Use threads M8 in left sideplate (pos.01)
2. Install side support (pos.02)
3. Install side support with internal wrenching bolt (M8x25-pos.03) and washer. (M8-pos.04)



CHRYSSAFIDIS

SPARE PARTS (GENERAL)

NOTE:

For spare parts not mentioned in list, contact Grinnell. Always mention drawing numbers in combination with POS numbers.

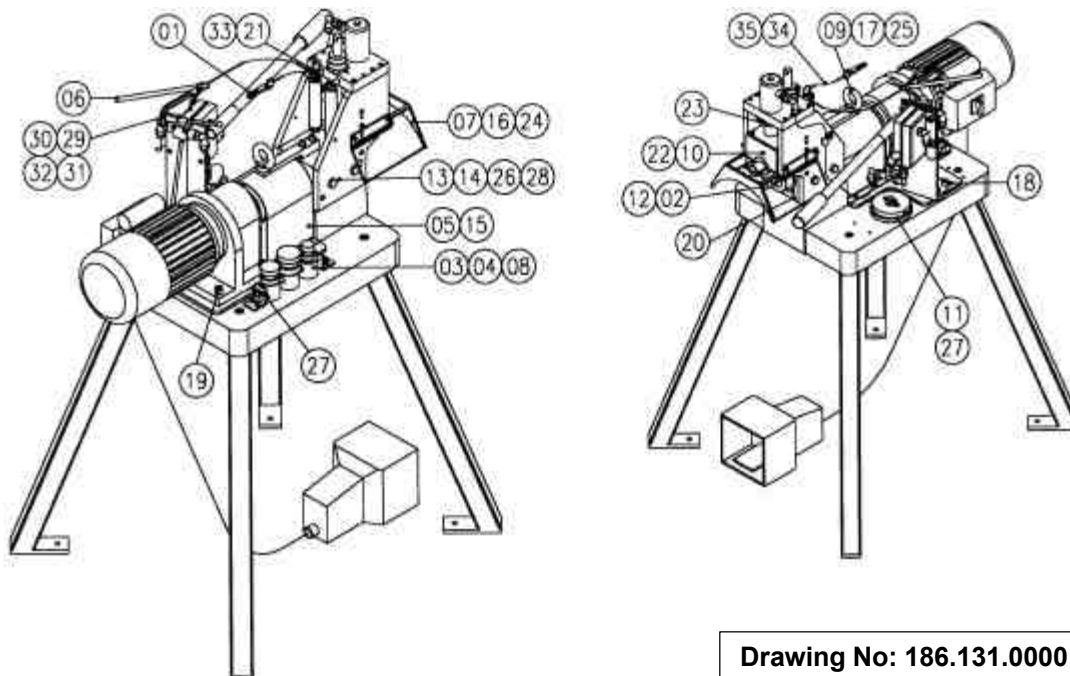

Drawing No: 186.131.0000

POS	Grinnell Article No	Description	POS	Grinnell Article No	Description
1	2861270048	Depth Gauge	19		Allen bolt M12x30
2	Z1300001	Bottom roll 1"	20		Allen bolt M12x40
3	Z1300002	Bottom roll 2" - 6"	21		Fit screw M8/10x20
4	Z1300003	Bottom roll 8"	22		Set bolt M8x10
5		Shaft cover	23		KM Nut 11 M55x1.5
6	2861300026	Pinion with chain	24		Ring M6
7	2861300028	Protective cover	25		Ring M8
8	Z1300001-A	Bottom roll 1¼" - 1½"	26		Pin Ø12x32
9		Hoisting point	27		Spring clip 2mm
10	Z1310004	Top roll 1" - 6"	28	2210100180	Lubricating nipple M10
11	Z1310005	Top roll 8"	29	ALLEN04	Allen key 4mm
12	2861310023	Locking pin for bottom roll	30	ALLEN10	Allen key 10mm
13		Bolt M12x25	31	ALLEN05	Allen key 5mm
14		Bolt M12x30	32	ZKLM015REV	Measuring tape
15		Allen bolt M6x10	33		Spring Ø27x95x3.5
16		Allen bolt M6x12	34		Chain 100mm / 400mm
17		Allen bolt M8x35	35		Ring Ø25
18		Allen bolt M10x25			



SPARE PARTS (HYDRAULIC PUMP UNIT)

NOTE:

For spare parts not mentioned in list, contact Grinnell. Always mention drawing numbers in combination with POS numbers.

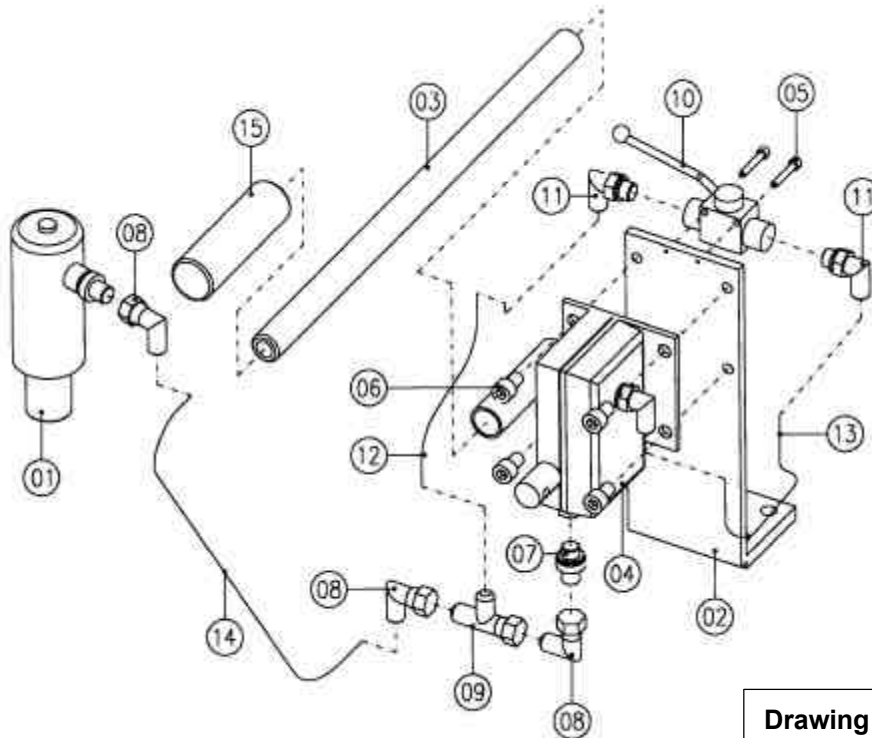

Drawing No: 186.131.3HYD

POS	Grinnell Article No	Description	POS	Grinnell Article No	Description
1		Hydraulic cylinder	9		Tee
2		Pump support	10		Hydraulic release valve
3		Handle pump	11		Elbow 6C40MXS
4	2861300025	Hydraulic hand pump	12		Hose L=170
5		Allen bolt M5x30	13		Hose L=350
6		Allen bolt M10x12	14		Hose L=500
7		Straight bolt	15		Handle
8		Elbow 6C6MXS			



CHRYSSAFIDIS

SPARE PARTS (BOTTOM ROLL UNIT + ENGINE)

NOTE:

For spare parts not mentioned in list, contact Grinnell. Always mention drawing numbers in combination with POS numbers.

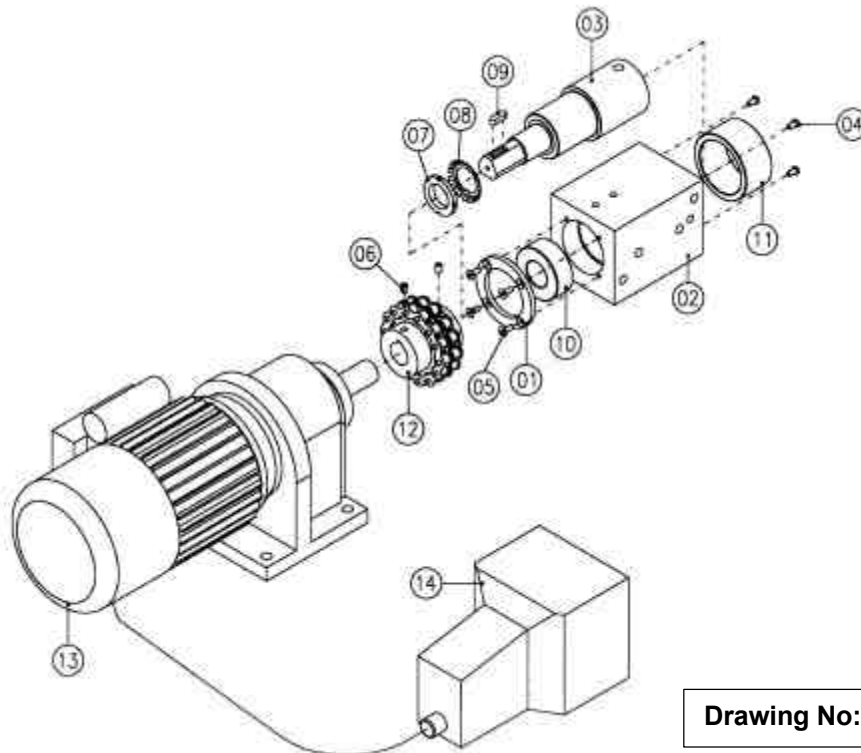

Drawing No: 286.131.3AAN

POS	Grinnell Article No	Description	POS	Grinnell Article No	Description
1		Locking ring	8		MB-Locking ring 7
2		Bearing block bottom shaft	9		Wedge 8x7x25
3	2861310014	Main shaft bottom roll	10	6101003207	Ball bearing bottom shaft
4		Cil. Bolts M6x12	11		Needle bearing bottom sh.
5		Cil. Bolts M6x16	12		Chain-coupling 3/4" z=14
6		Set bolt M8x10	13		Motor 220V/1Ph
7		KM-Nut 07	14		Foot switch



CHRYSSAFIDIS

SPARE PARTS (TOP ROLL UNIT)

NOTE:

For spare parts not mentioned in list, contact Grinnell. Always mention drawing numbers in combination with POS numbers.

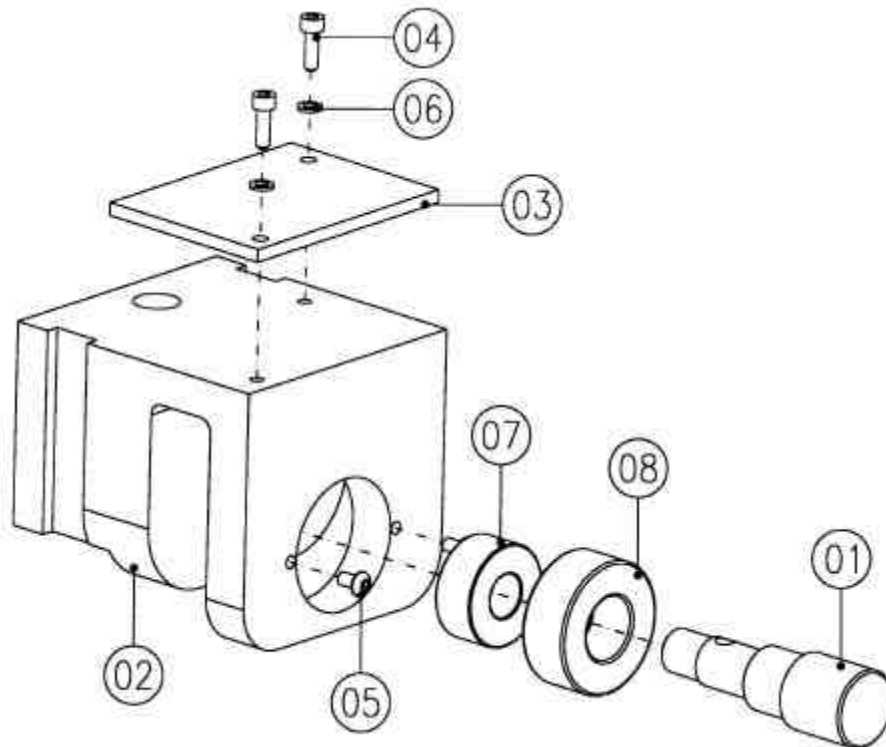

Drawing No: 286.131.3TOP

POS	Grinnell Article No	Description	POS	Grinnell Article No	Description
1	2861300013	Top roll shaft	5		Cil. Bolt M5x10
2	2861310010	Top roll unit	6		Spring ring M5
3	2861310030*	Pressure strip	7	3211003203	Ball bearing 3203-2RS
4		Allen bolt M5x16	8	3211003205	Ball bearing 3205-2RS

*) Pressure strip [pos 03] will be delivered with Top Roll Unit [pos 02].



CHRYSSAFIDIS

SPARE PARTS (FRAME UNIT)

NOTE:

For spare parts not mentioned in list, contact Grinnell. Always mention drawing numbers in combination with POS numbers.

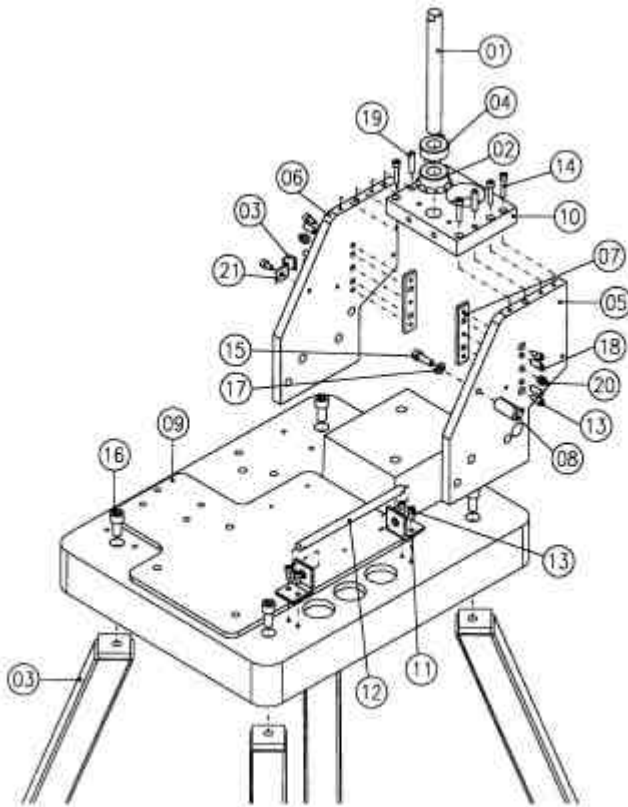

Drawing No: 286.131.3FRM

POS	Grinnell Article No	Description	POS	Grinnell Article No	Description
1		Threaded rod depth adjust.	12		Pin bottom roll holder
2	2861270037	Set nut depth adjustment	13		Allen bolt M6x12
3	2861270040	Leg	14		Allen bolt M6x30
4	2861270044	Locking nut depth adjust.	15		Allen bolt M8x25
5		Side mount left	16		Allen bolt M12x25
6		Side mount right	17		Ring M8
7		Guide	18		Pin Ø8x20
8		Pin for base plate	19		Pin Ø8x32
9		Base plate	20	2210100180	Lubricating nipple M10
10		Top plate	21		Hose clamp
11		Support bottom roll holder			