



**PEMA  
ROLLER BEDS**

**WORKPIECE  
HANDLING  
EQUIPMENT**

D13853-2

# PEMA TNA

## Conventional roller beds





# PEMA TNA ROLLER BEDS



PEMA TNA conventional roller beds are a basic solution for handling of the pressured vessels and tanks in automated welding.

They occupy little space thanks to compact size. Roller distance is adjusted for different diameters of the workpiece manually. The adjustment is stepless in the smaller models, the bigger roller beds are equipped with stepped adjustment in order to get appropriate setting of the rollers.

The TNA-range offers models for 10 tons up to even 1200 tons roller beds. The bigger roller beds are often the part of PEMA engineering solutions.

350 tons - 1200 tons idler units are always equipped with automatic Anti-Creep equipment, which keep the vessel axially still, this system is necessary for trouble-free narrow gap welding.

For wind towers and other conical work pieces there are available TNAW-serie's roller beds.

All PEMA roller beds have machined frames and other parts and all constructions are designed by using safety factors. The material of the rollers is polyurethane and in bigger roller beds high quality steel.

Powerful and accurate rotation is essential factor when the high quality welds are required, in all PEMA roller beds this is ensured by using high quality inverter controlled AC-drives and gears.

## ROLLER BED FACTS:

- Quality improves - less finishing or repairing
- Accurately, safely and ergonomically
- Necessary for all automated welding of the cylindrical work pieces with column & boom
- PEMA-products fulfill European EN-safety norms and they are equipped with CE-mark

PEMA roller beds are equipped with handy remote control for all electrical operations and they are delivered ready to use.

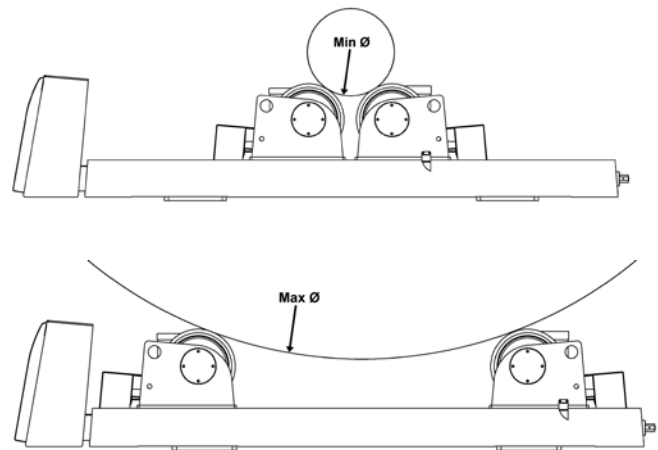

	Model	10 TNA	25 TNA	40 TNA	60 TNA	100 TNA	150 TNA	200 TNA	350 TNA
Max load (ton/section)	power	5	12.5	20	30	50	75	100	150
	idler	5	12.5	20	30	50	75	100	150
Rolling capacity (ton)		15	37,5	60	90	150	225	300	450
Max rotation force (kN)		11	20	45	55	75	110	165	210
Rotation speed range (mm/min)		60 - 1250	60 - 1250	60 - 1250	60 - 1250	60 - 1250	60 - 1250	60 - 1250	60 - 1250
Diameter range min-max (mm)		350 - 4500	350 - 4500	550 - 5000	600 - 5000	500 - 7500	500 - 7500	1000 - 7500	1000 - 7800
Rollers (pcs/section)		4	6	4	2	4	2	2	2
Roller diameter/total width (mm)		350 / 155	350 / 235	440 / 310	620 / 220	580 / 470	580 / 220	580 / 220	710 / 350
Roller material		PU	PU	PU	PU	PU	steel	steel	steel
Length (mm)	power	3040	3110	3650	3780	5790	5780	6420	6040
	idler	2680	2690	3000	3300	4230	4230	4200	7020
Width (mm)	power	660	710	1200	1190	1100	1100	1100	1780
	idler	490	490	830	830	1100	1100	1100	1300
Weight (kg)	power	570	1050	1650	1950	5170	5200	6040	10600
	idler	470	680	1520	1510	3710	3710	3710	11800
Remote control		included	included	included	included	included	included	included	included
Mains supply connection 50 Hz		3x400V+N+PE	3x400V+N+PE	3x400V+N+PE	3x400V+N+PE	3x400V+N+PE	3x400V+N+PE	3x400V+N+PE	3x400V+N+PE
Power (A)		16	16	25	25	25	25	25	25

Model	500 TNA	700 TNA	1200 TNA
power		For technical information, contact Pemamek.	
idler			

## Options

- Foot pedal for start/stop of rotation
- Foot pedal for speed control
- External control of rotation
- Rail carriages
- Automatic AntiCreep
- Wireless remote control

# PEMA TA

## Self-aligning roller beds

- Ideal for difficult and demanding workpieces
- Provide even weight distribution
- No separate adjustment for different diameters

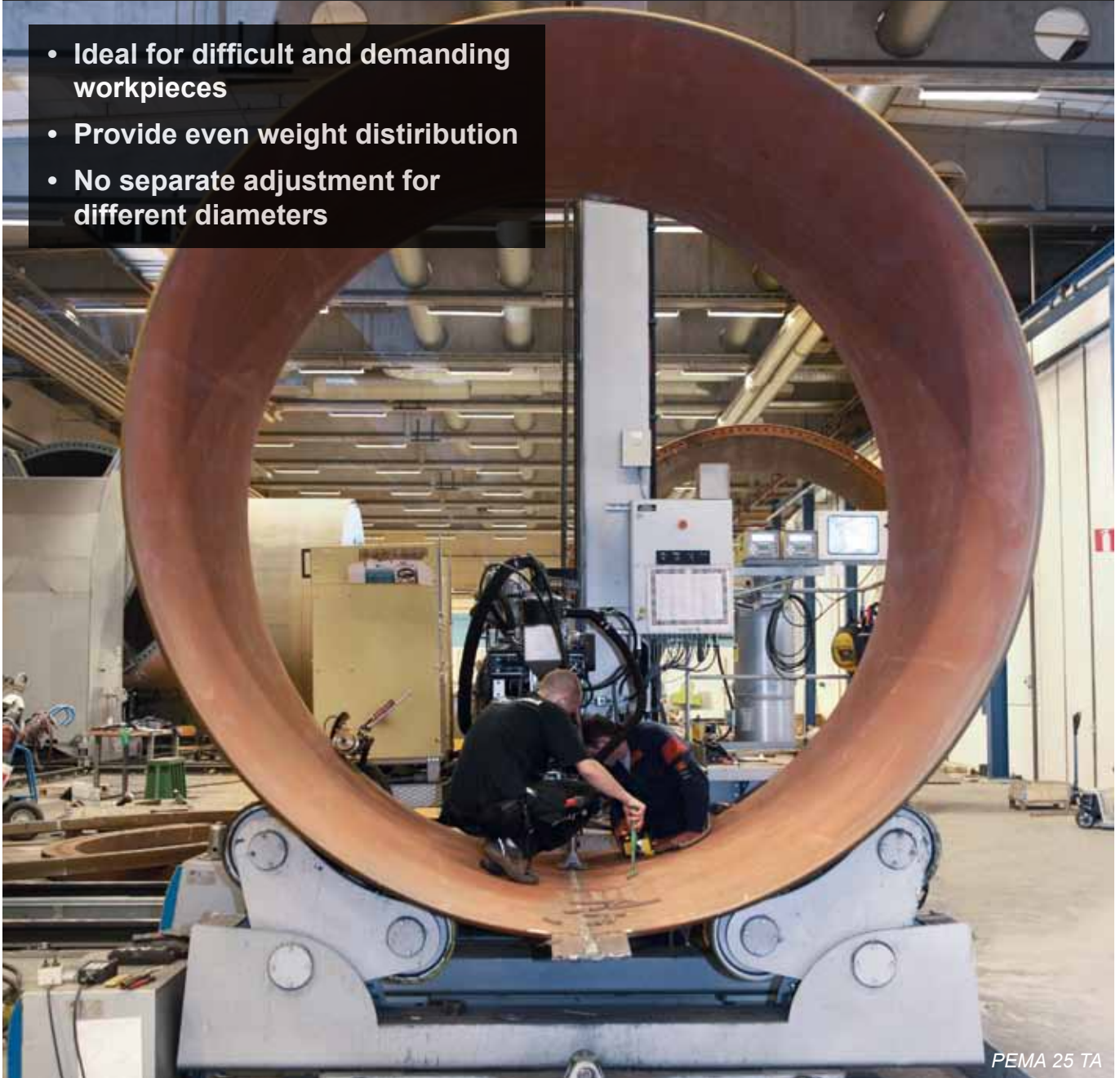

PEMA 25 TA



PEMA 10 TA



PEMA self-aligning roller bed

# PEMA TA ROLLER BEDS



PEMA TA self-aligning roller beds are ideal for difficult and demanding work pieces. The roller bogies align itself automatically with the diameter of the workpiece in question. Compared with the TNA model, the TA series enables a more even weight distribution, which is a significant advantage when welding thin walled work pieces and vessels.

All four roller axles of the power unit are driven, except in TAW-versions. This four wheel drive offers the accurate rotation even for the most difficult and unbalanced work pieces.

For wind towers and other conical work pieces there are available TAW-series roller beds.

All PEMA roller beds are designed based on the years experience and close co-operation with specialists of welding production.

Every PEMA roller bed and positioner is made by using high quality components which represent internationally well-known brands. All constructions and components are tested and made in long series.

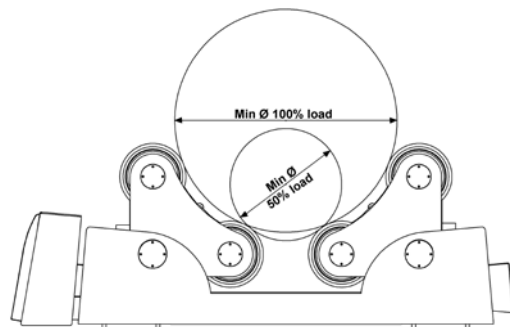
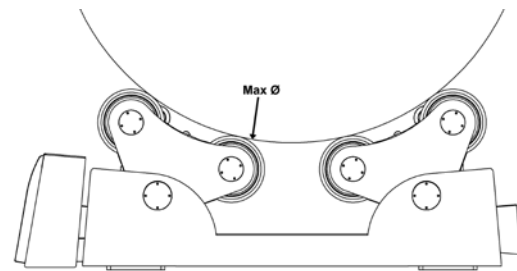

	Model	10 TA	25 TA	40 TA	70 TA	100 TA	150 TA	200 TA	300 TA	500 TA
Max load (ton/section)	power	5	12.5	20	35	50	75	100	150	250
	idler	5	12.5	20	35	50	75	100	150	250
Rolling capacity (ton)		15	37.5	60	105	150	225	300	450	
Max rotation force (kN)		11	20	32	60	75	110	165	210	
Rotation speed range (mm/min)		60 - 1250	60 - 1250	60 - 1250	60 - 1250	60 - 1250	60 - 1250	60 - 1250	60 - 1250	
Diameter range min-max (mm)	50% load	500 - 4500	500 - 4500	1000 - 5200	1000 - 5200	1000 - 7000	1000 - 7000	1000 - 7000	2000 - 8500	
	100% load	1250 - 4500	1250 - 4500	1750 - 5200	1750 - 5200	2000 - 7000	2000 - 7000	2000 - 7000	4000-8500	
Rollers (pcs/section))		4	8	4	8	4	8	4	4	
Roller diameter / total width (mm)		350/75	350/150	425/150	425/300	580/220	580/450	580/220	710/260	
Roller material		PU	PU	PU	PU	PU	PU	steel	steel	
Length (mm))	power	2690	2740	3140	3250	3950	4120	4120	4840	
	idler	2200	2200	2710	2710	3430	3430	3950	4860	
Width (mm)	power	730	800	1200	1280	1630	1880	1630	2000	
	idler	490	490	830	830	1100	1100	920	1280	
Weight (kg)	power	925	1050	1780	2450	5000	7300	6200	12000	
	idler	590	740	1200	1870	3500	5200	4700	10000	
Remote control		included	included	included	included	included	included	included	included	included
Mains supply connection 50 Hz		all models 3x400V+N+PE								
Power (A)		16	16	16	25	25	25	25	25	25

For technical information, contact Pemamek.



# PEMA TAW - TNAW

Roller beds for windmill tower production



- For rotating conical tower sections
- Self-aligning TAW up to 70 tons and conventional TNAW models up to 140 tons
- Special constructions for ATEX-areas

PEMA 70 TAW with rail carriage



PEMA 80 TNAWS ATEX



PEMA 140 TNAW roller bed

# PEMA TAW & TNAW ROLLER BEDS



For rotating and handling of the tower sections Pemamek offers two range of roller beds.

TNAW-serie is the basic solution and it is available as 60 tons and 140 tons models.

TAW-serie is based on the self-aligning construction and it is manufactured as 25, 40 and 70 tons models.

PEMA-roller beds are used in all work stations where towers and shells are rotated. We have suitable roller beds for longitudinal welding of single shells, welding of end flanges, welding of shells together, internal welding of towers and handling of the welded tower in finishing station, like welding of doors.

Roller beds are equipped with special polyurethane rollers, which are designed for conical towers, too. Gears and motors have high torque to rotate the most heavy tower sections. Rotation speed is controlled via top quality inverter. Rotation speed and direction are set from a handy remote controller.

As options there are available rail carriages, special constructions for ATEX-areas and hydraulic fit-up equipment among others.



PEMA 25 TAW set is used for welding of shells and flanges

	Models	60 TNAW	140 TNAW	25 TAW	40 TAW	70 TAW
Max. loading (tons / unit)		30	70	12,5	20	35
Max. loading (tons/set)		60	140	25	40	70
Max rotation capacity (tons)		90	140	37,5	60	105
Rotation force (kN)		25	60	20	32	60
Rotation speed (mm/min)		100-2000	100-2000	60-1250	60-1250	60-1250
Diameter range (mm)		2000-5000	2200-6000	1500-4800	1000-5200	1000-5200
PU-rollers (pcs/unit)		2	4	8	4	8
Roller dia - width total (mm)		620-220	620-450	350-150	440-150	440-300
Length of power unit (mm)		3810	4495	3312	3140	3250
Length of idler unit (mm)		3520	3990	2859	2710	2710
Height (mm)		713	762	955	1126	1126
Width (mm) power/idler		920/448	1365/732	797/490	1200/830	1280/830
Weight (kg) power/idler		1286/1047	2650/1945	1274/ 800	1770/1220	2430/1870
Power A		16 A	20 A	25 A	35 A	50 A
Standard supply voltage 400 V - 3 ph+PE+neutral - 50 Hz, supply cable 12 m.						

## PEMA RAIL CARRIAGES FOR ROLLER BEDS

Rail bogies	10 RBPA/RBIA	25 RBPA/RBIA	40 RBPA/RBIA	70 RBPA/RBIA	100 RBPA/RBIA	150 RBPA/RBIA	200 RBPA/RBI	300 RBPA/RBIA
Suitable for TNA-models	10 TNA	25 TNA	40 TNA	60 TNA	100 TNA	150 TNA	200 TNA	300 TNA
TA-models	10 TA	25 TA	40 TA	70 TA	100 TA	150 TA	200 TA	300 TA
Max load (ton/section)	5	12.5	20	35	50	75	100	150
Rail wheel dia (mm)	246	246	310	310	370	370	370	370
Rail width (mm)	45-65	55-75	55-75	55-75	55-75	55-75	55-75	75-100
Recommended rail type	A 55	A 55	A 55	A 55	A 65	A 65	A 65-A75	A75
Adj. rail width i-to-i (mm)	1425 - 1825	1425 - 1825	1375 - 1875	1375 - 1875	1730 - 2300	1730 - 2300	1730 - 2300	1730-2300
Travel speed (mm/min)	2 300	2 300	1 350	1 350	1 350	1 350	1 350	1 350
Height (mm)	191	191	223	223	375	375	375	375
Length (mm)	1450	1450	1910	1910	2320	2320	2610	2610
Width (mm) power	603	603	720	720	720	720	770	770
(mm) idler	300	300	340	340	400	400	340	340
Weight (kg) power	200	200	380	380	880	880	860	860
(kg) idler	180	180	340	340	720	720	700	700
RBPA = Motorised rail carriage, RBIA = Idler rail carriage								



## ENGINEERING SOLUTIONS

Pemamek Ltd designs and manufacturers customised engineering solutions of automated welding of heavy work pieces. Typically power plant supplying industry, off-shore and marine component industry are the users of these applications.

Often the station comprises positioners or heavy duty roller beds with automatic anti-creep equipment, rigid column & boom with sub merged arc process like tandem SAW, narrow gap, strip cladding and advanced integration of the all functions.

PEMA's roller beds of sizes 200 tons and bigger ones up to 1200 tons are designed specially for the demands which these applications set.



Due to continuous R & D Pemamek Oy reserves the right to change the specification without notice.



### PEMA – WORLD CLASS WELDING AUTOMATION

Established in 1970, PEMAMEK OY LTD is a top-ranking expert in welding automation and work-piece handling equipment.

The company supplies PEMA welding automation and work-piece handling equipment for workshop industry, energy sector and shipbuilders.

Over 85% of Pemamek's production is exported all over the world.

#### PEMAMEK OY

Lamminkatu 47  
FI-32201 Loimaa  
Finland

Phone: +358 2 760 771  
Fax: +358 2 762 8660  
www.pemamek.com

- HEAVY ENGINEERING
- MOBILE MACHINERY
- CIVIL CONSTRUCTION
- PROCESS AND NUCLEAR
- WIND ENERGY
- INDUSTRIAL BOILERS
- SHIPBUILDING AND OFFSHORE
- CUSTOMER SUPPORT