

I-GUIDE

GC-RÄCKESSYSTEM/GC BARRIER SYSTEM

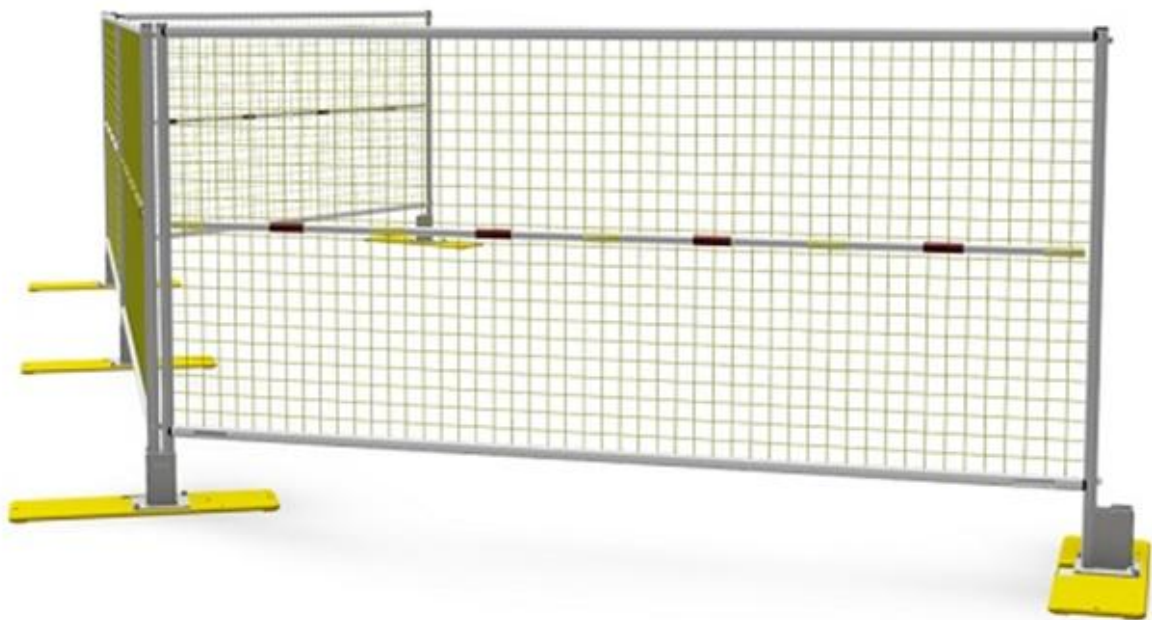

Om SafePass GC-Räckessystem

SafePass GC-räckessystem är ett skyddsanordningssystem för gång- och cykelvägar (GC) som avser att öka tryggheten på vägarbetsplatser. Räckessystemet bör kompletteras med vägledande skyltning. Montera systemet på ett sätt som säkerställer funktion och stadga.

Om SafePass GC LED-System

GC-Räcke LED används när synbarheten hos systemet behöver förstärkas nattetid. Räckets är försett med en ljusslinga i färgen amber som ger ett tydligt och ledande ljus. Systemet kan drivas med SafePass™ 230V/48V Nätaggregat eller med SafePass™ 48V Batteriaggregat. Nätaggregatet kan driva upp till 100 st GC-Räcken LED. Batteriaggregatet består av fyra stycken 12V 75Ah batterier och är försett med en ljussensor som gör systemet energisnålt. Med batteriaggregatet kan upp till 40 st GC-Räcke LED drivas.

Generella krav

- ! Gör alltid en riskbedömning och metodbeskrivning före montering.
- ! Gör en säkerhetsbesiktning av produkterna före användning.
- ! Använd aldrig skadade eller rostiga produkter.
- ! Använd lämpliga verktyg för montering.
- ! Använd lyftanordningar med tillräcklig lastkapacitet.
- ! Använd lämplig personlig skyddsutrustning.
- ! Används fallskyddsutrustning vid arbete på höjd.
- ! Montering/hantering av GC LED Systemet ska göras av kompetent, utbildad personal.
- ! Safety Solutions Jonsereds (SSJ) produktansvar gäller endast kombinationer av SSJ-produkter som monterats enligt SSJs I-Guides.
- ! Inga förändringar i systemets konstruktion får göras utan samråd med SSJ.
- ! Se till att fullständig och aktuell information (manualer etc) finns tillgänglig på site.

About SafePass GC Barrier system

SafePass™ GC Barrier system is intended for use as a work zone protection at pedestrian/bicycle lanes. The system should be complemented with sufficient traffic signs. Install the system in a way that ensures functionality and stability.

About SafePass GC LED system

Use the SafePass™ GC LED Barrier system when there is a need to enhance visibility, e.g. night time. The barrier has integrated LED lights with the colour "amber". The system can be powered using either the SafePass™ 230V/48V Converter or the SafePass™ 48V Off Grid Power Box. The converter can power a maximum of 100 GC Barrier LED. The power box consists of 4x 12V 75Ah batteries and has a light sensor to minimize energy consumption. The power box can power up to 40x GC LED Barriers.

General requirements

- ! Always do an assessment and a method statement for the installation.
- ! Perform a safety inspection on products before use.
- ! Never use damaged or rusty materials.
- ! Use tools intended for the installation.
- ! Use lifting equipment with sufficient load capacity.
- ! Use adequate personal protection equipment.
- ! Use personal fall arrest equipment when working at height.
- ! Installation and handling shall be done by trained, competent personnel.
- ! Safety Solutions Jonsereds' (SSJ) product liability only applies to combinations of SSJ products that are assembled according to SSJ's I-guides.
- ! No design changes may be made without consulting SSJ.
- ! Make sure all documentation needed is available and up-to-date.

GC-RÄCKESSYSTEM/GC BARRIER SYSTEM

GC-RÄCKE/GC BARRIER

9-760-01-001

14 kg

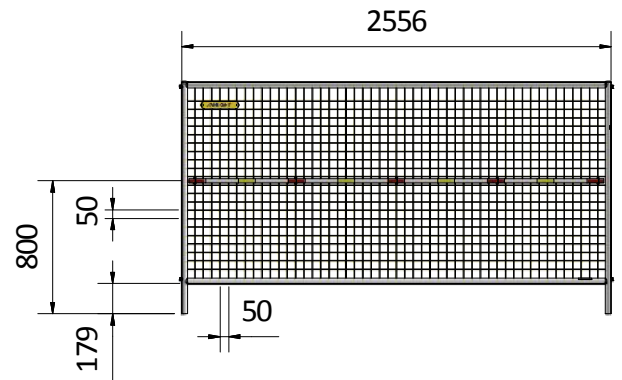
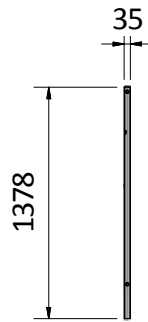
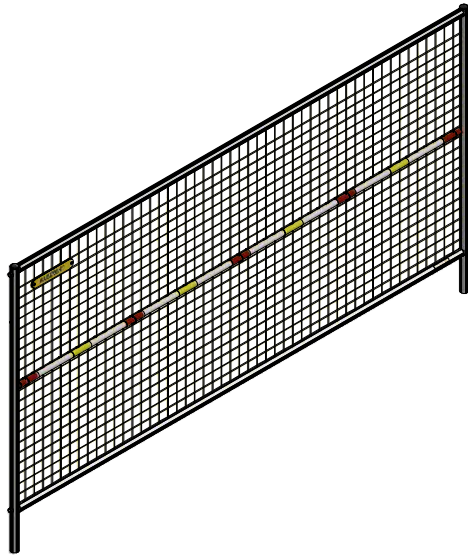

GC-RÄCKE/GC BARRIER 0,65 m

9-760-01-044

5,5 kg

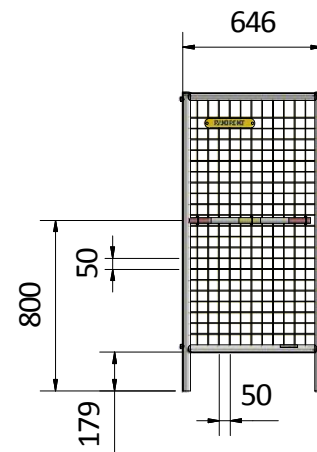
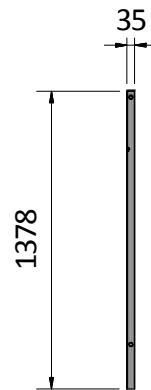
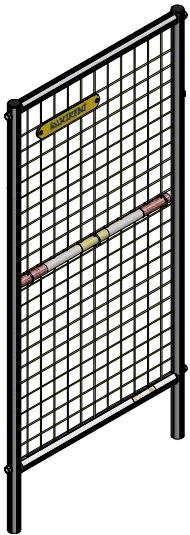

GC-RÄCKE XL/GC BARRIER XL

9-760-01-041

19 kg

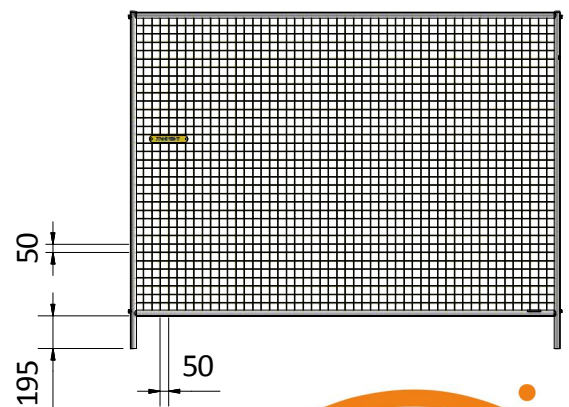
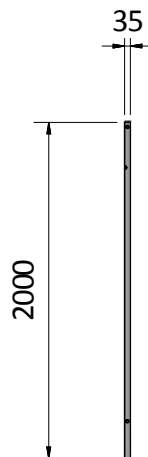
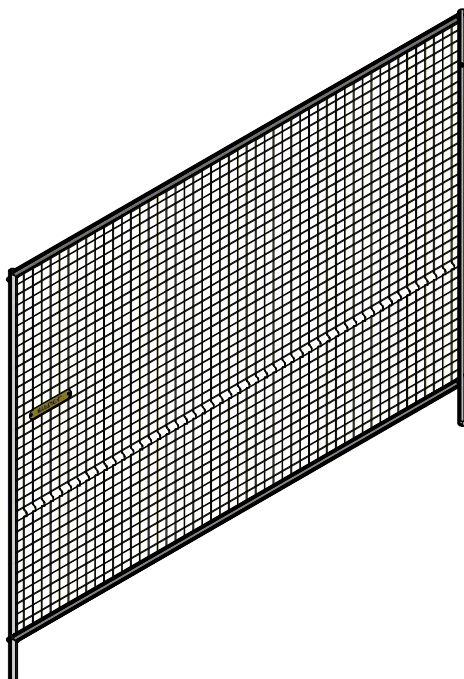

GC-RÄCKESSYSTEM/GC BARRIER SYSTEM

GC RÄCKESKLÄMMA/GC BARRIER CLAMP

9-760-01-024

Galvanized

0,25 kg

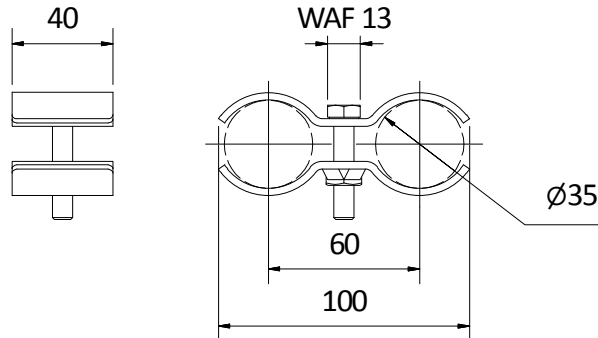
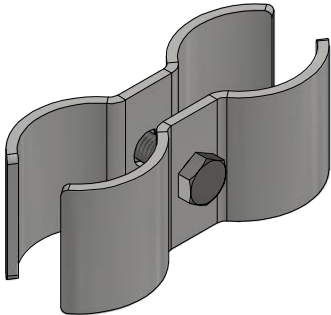

GC BÄRHANDTAG/GC CARRYING HANDLE

9-760-01-028

Powder coating

0,8 kg

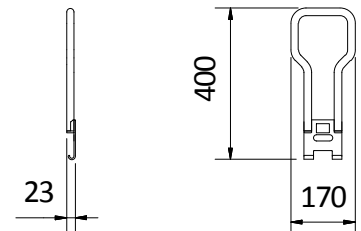
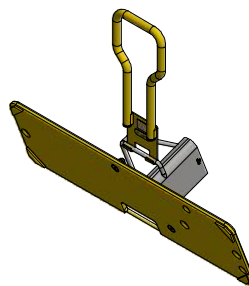
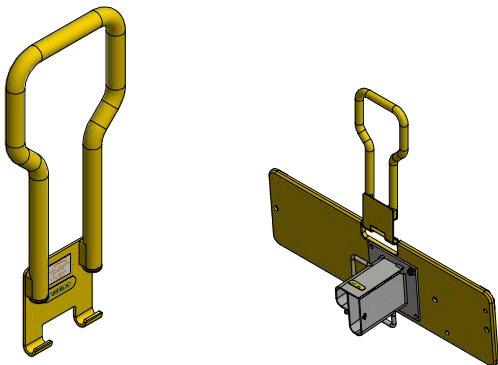

GC-FOT/GC FOOT

9-760-01-012

Galvanized & sand mixed paint

18,0 kg

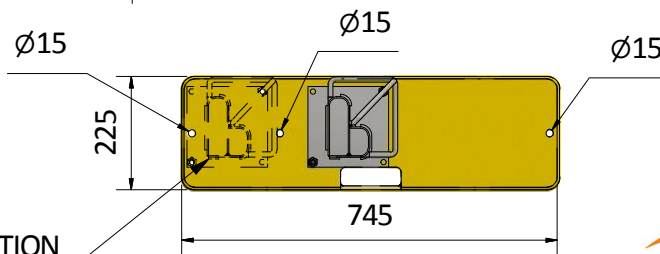
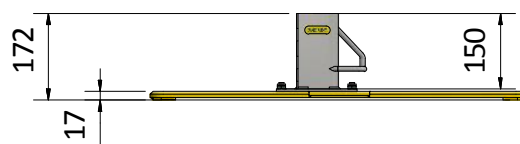
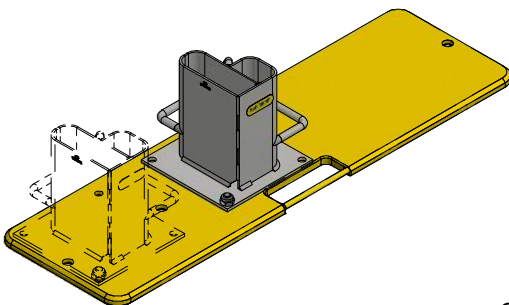

ALTERNATIVE SLEEVE POSITION

4 / 20

GC-RÄCKESSYSTEM/GC BARRIER SYSTEM

Montage/Installation

$\geq 18 \text{ m/s}$



ALT 1

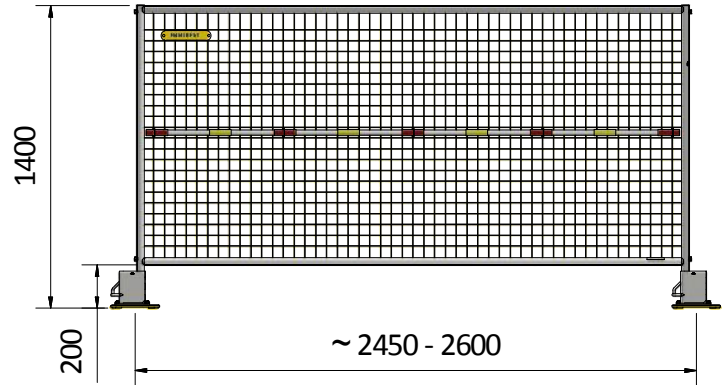
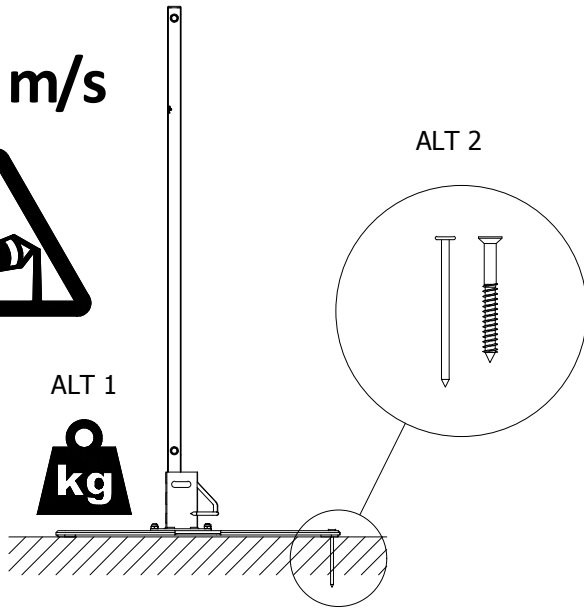

$\geq 16 \text{ m/s}$



ALT 1

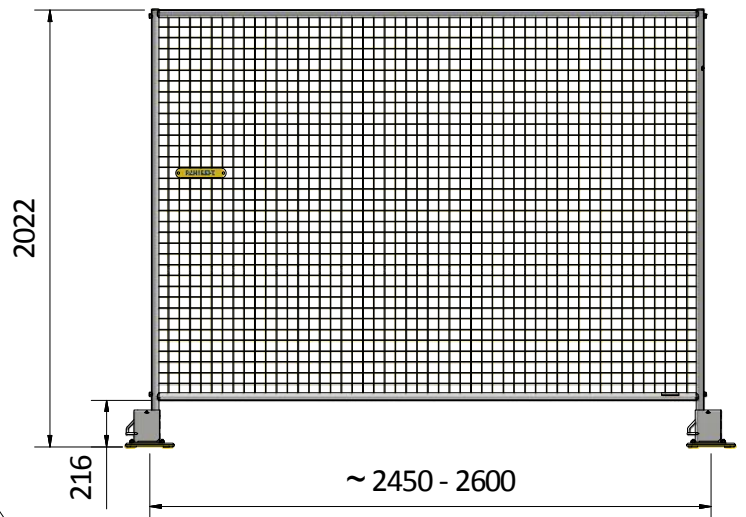
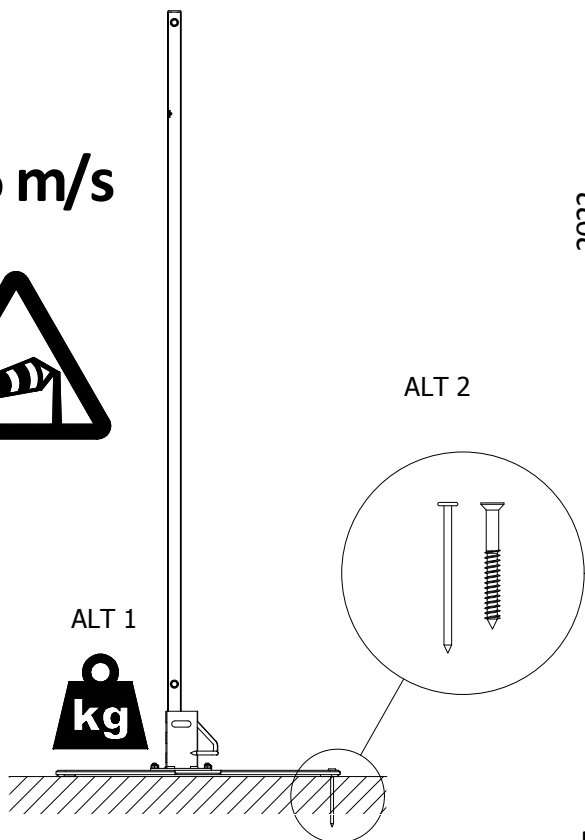

GC-RÄCKESSYSTEM/GC BARRIER SYSTEM

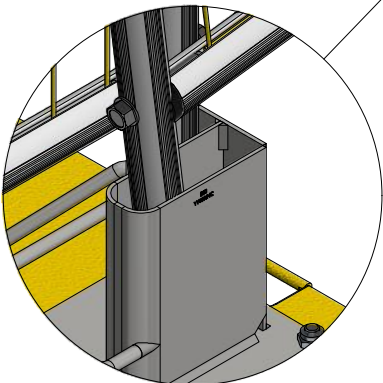
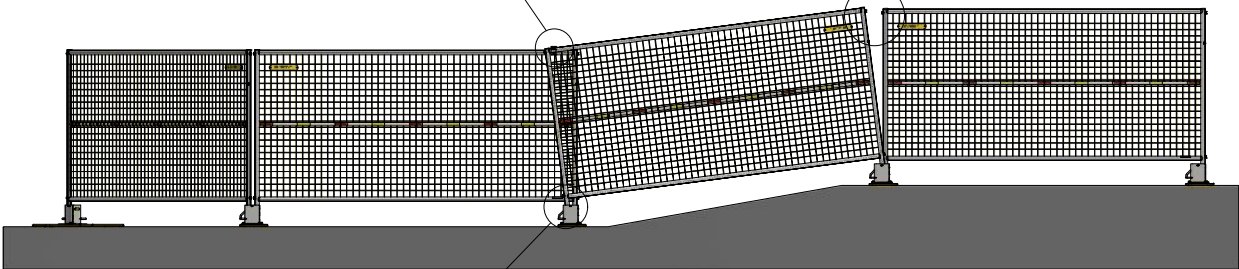
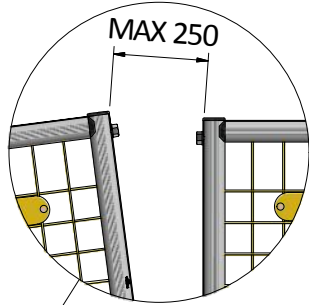
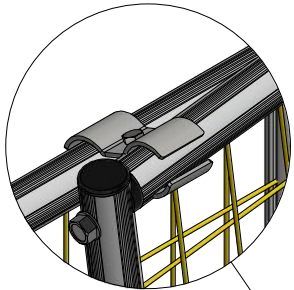
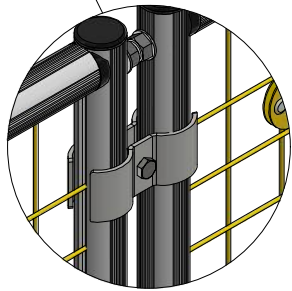
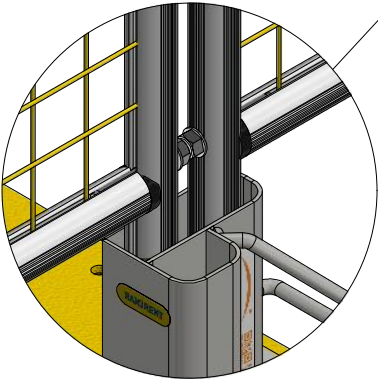
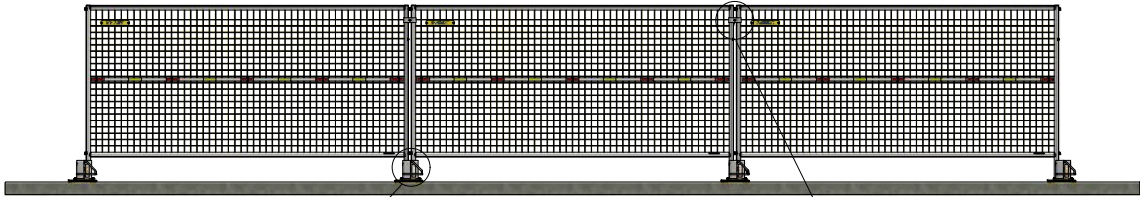

GC-RÄCKESSYSTEM/GC BARRIER SYSTEM

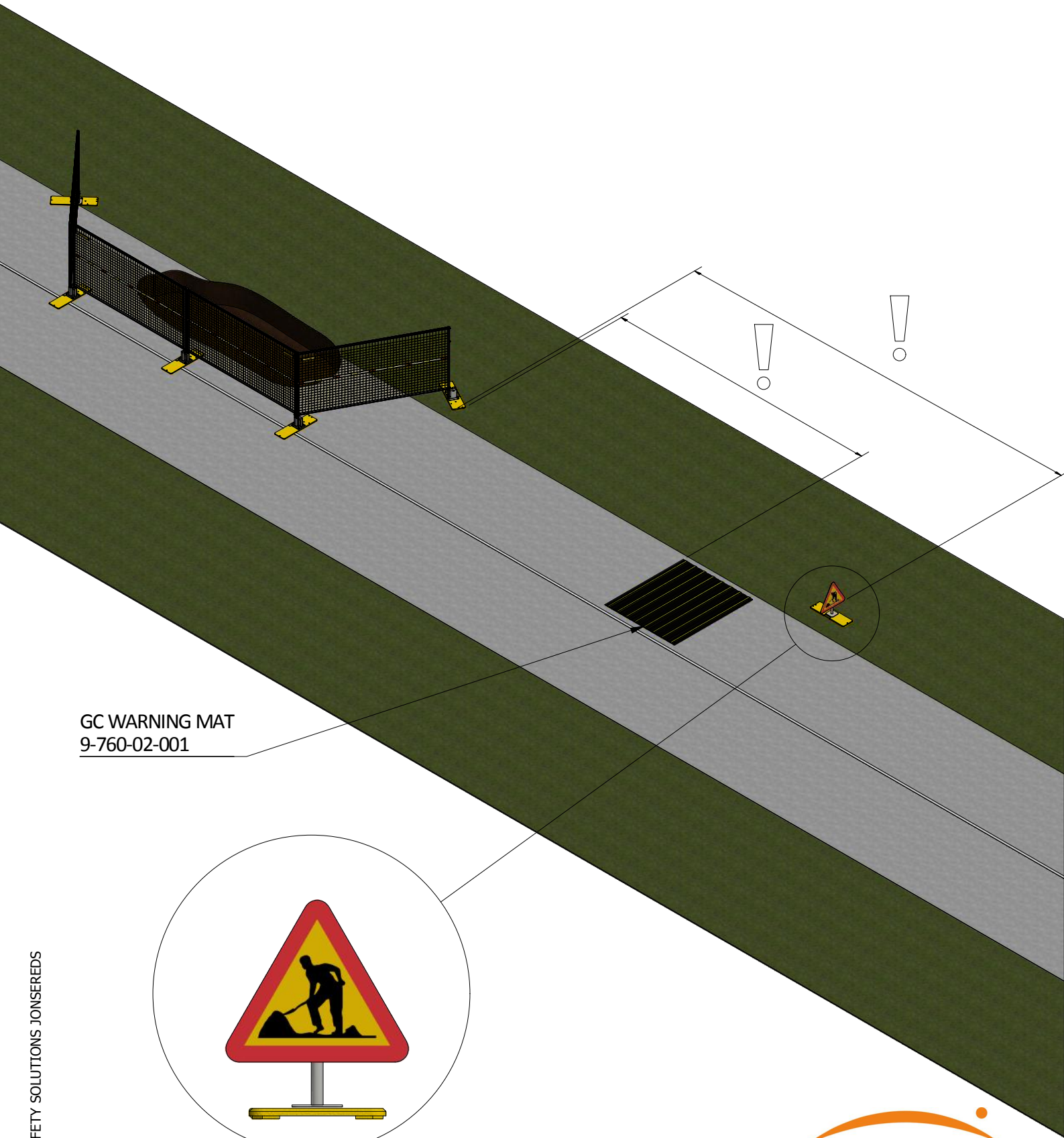

GC WARNING MAT
9-760-02-001



SAFEPASS™ GC LED SYSTEM

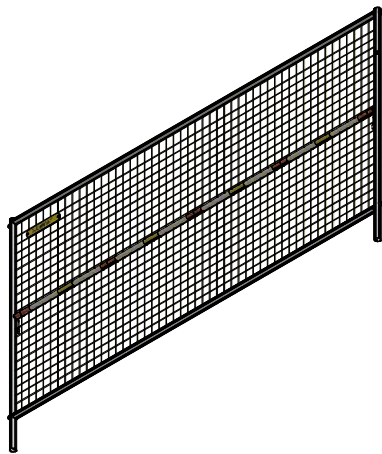

GC-RÄCKE LED/GC LED BARRIER

9-760-01-032
14,2 kg

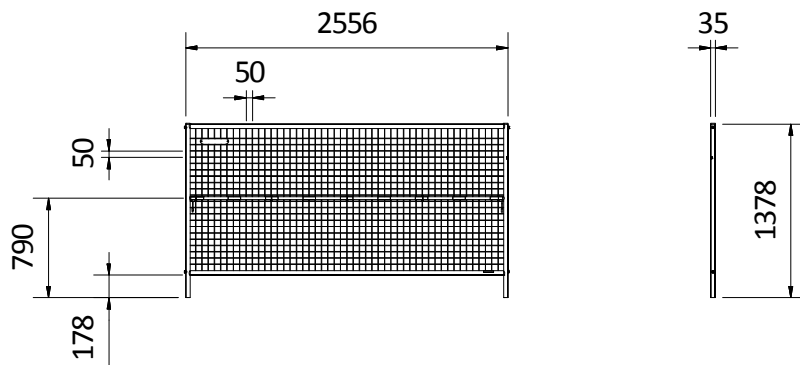

230V/48V NÄTAGGREGAT/CONVERTER

9-761-00-040
2,2 kg

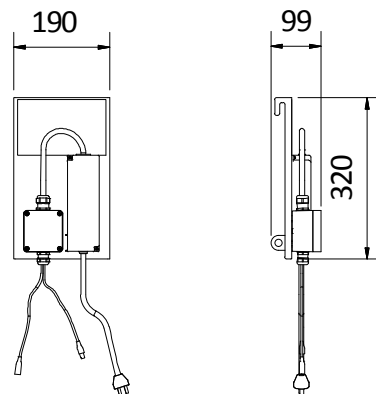
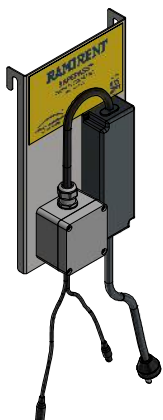

BATTERIAGGREGAT/OFF GRID POWER BOX 48 V

9-761-00-001
117 kg
4x 12V 75 Ah

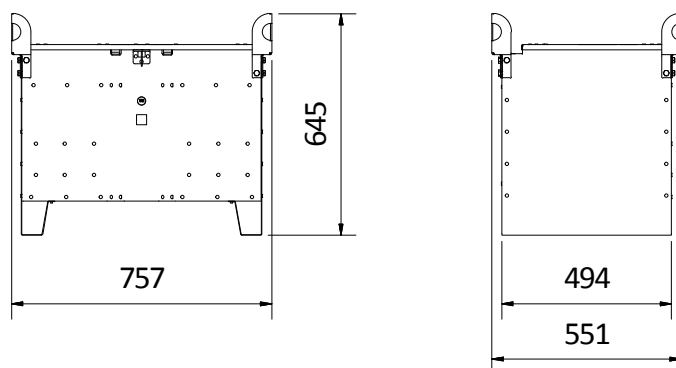
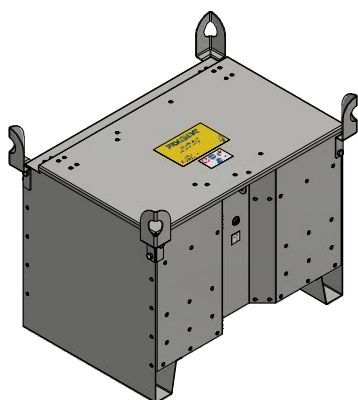

SAFEPASS™ GC LED SYSTEM

FÖRLÄNGNINGSSLADD/EXTENSION CORD 3 M

9-760-01-040

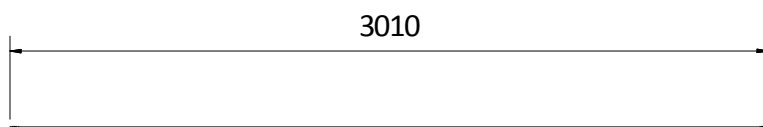
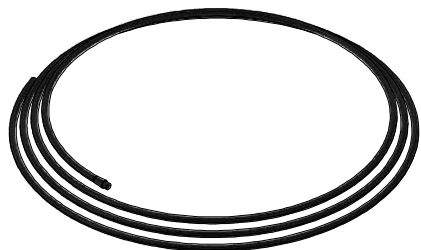

Montage/Installation

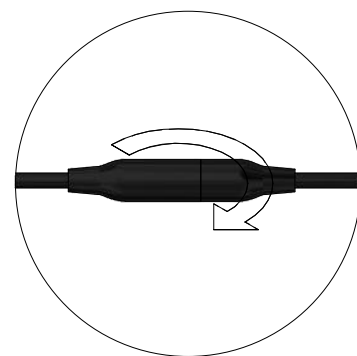
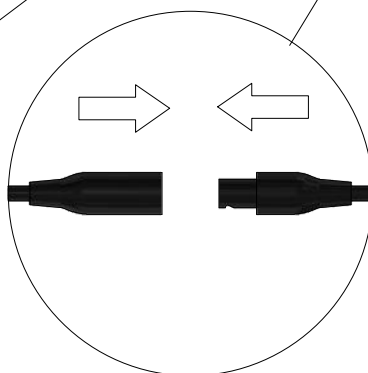
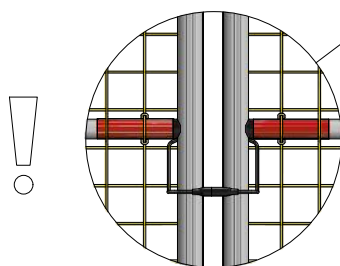
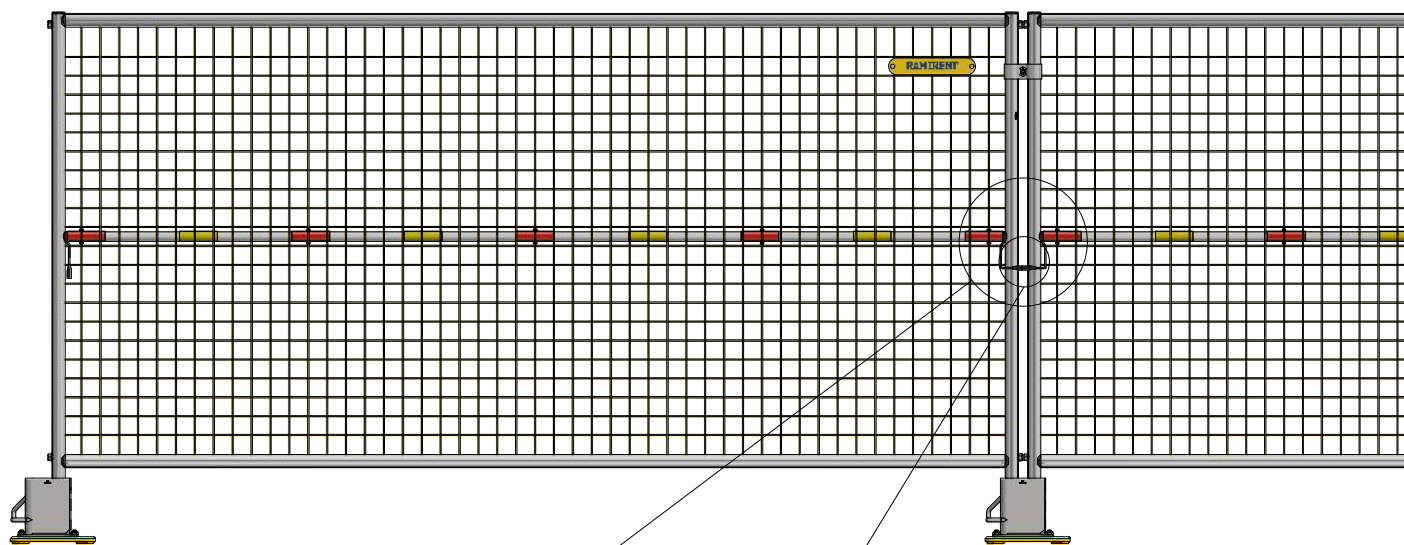

Placera räcken så att hona möter hane.

Place barriers so that female connector meets male connector.

SAFEPASS™ GC LED SYSTEM

ALT 1 → PAGE 11

MAX 100x

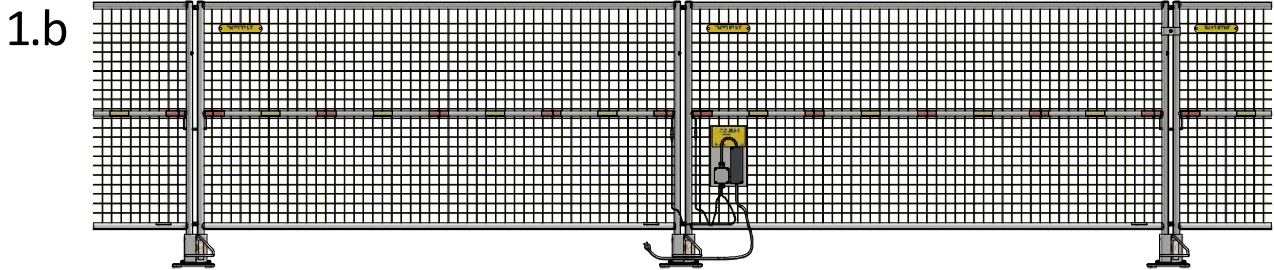
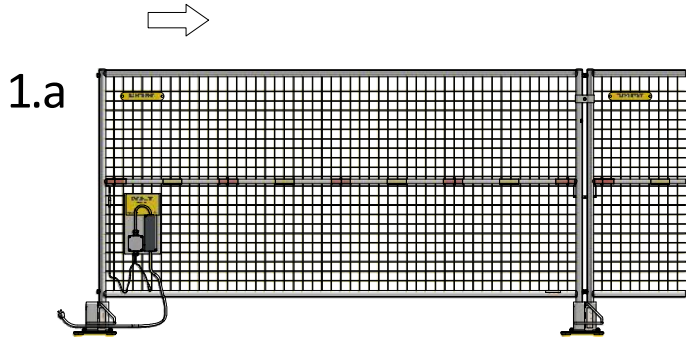
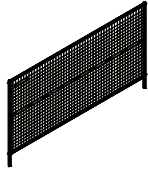

ALT 2 → PAGE 12

MAX 40x

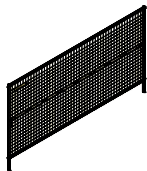

EXTENSION CORD 3 M
9-760-01-040

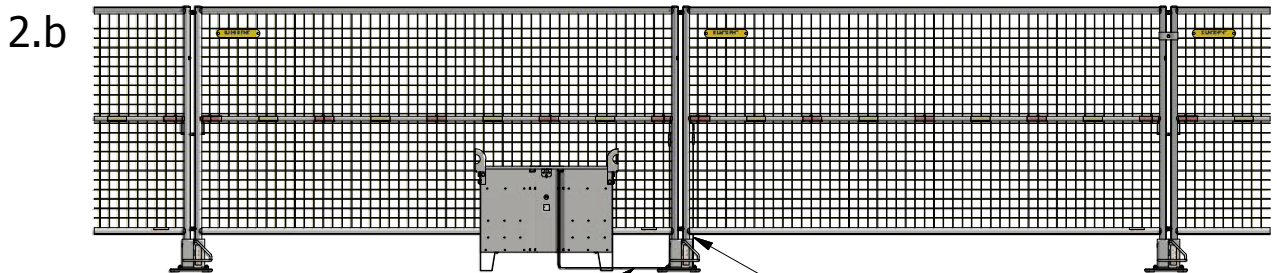
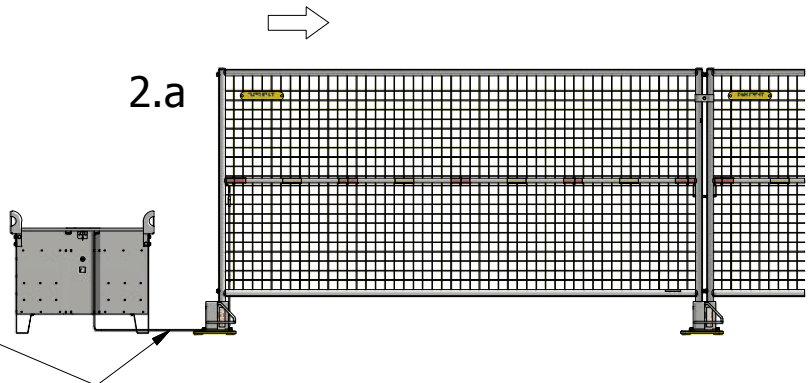

2x EXTENSION CORD 3 M
9-760-01-040

230/48V NÄTAGGREGAT/CONVERTER

ALT 1:

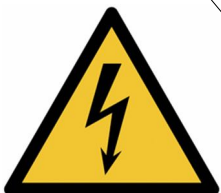
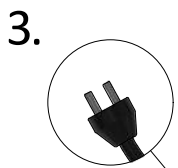
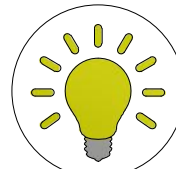
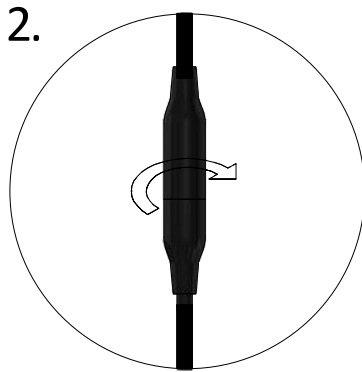
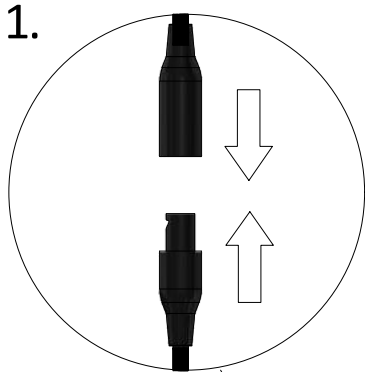
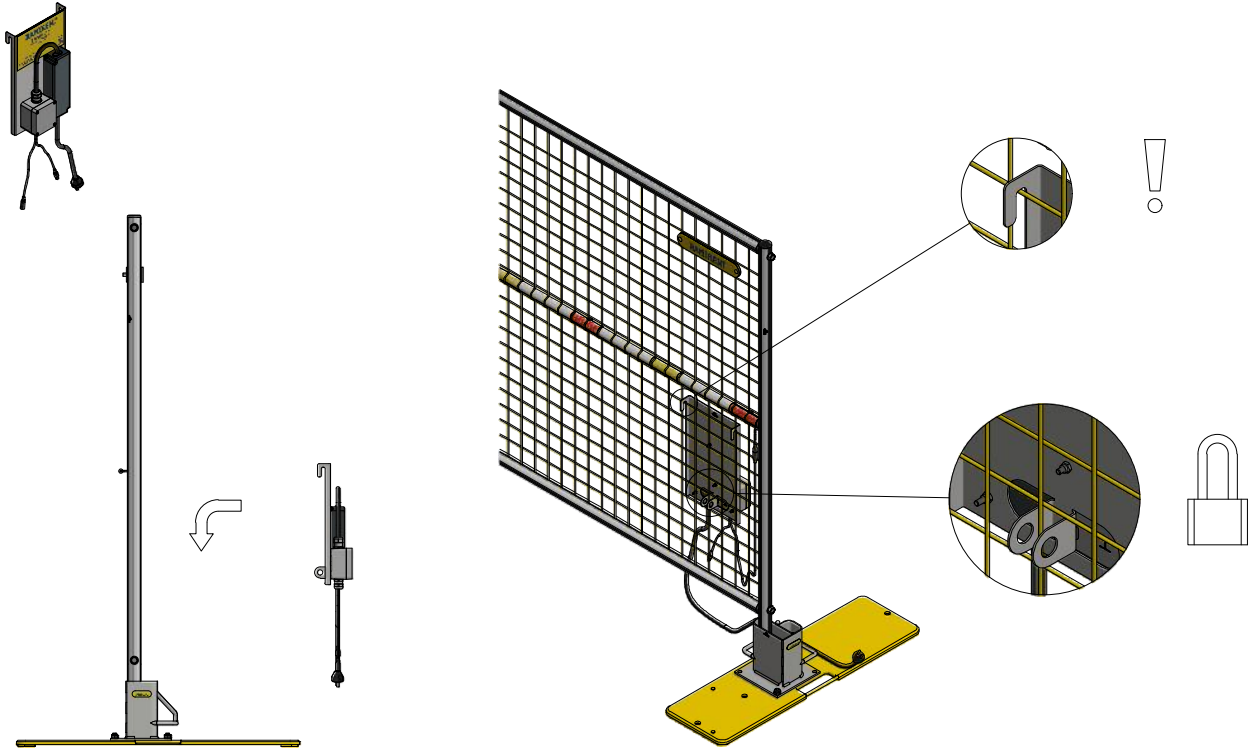

BATTERIAGGREGAT/OFF GRID POWER BOX 48V

ALT 2:

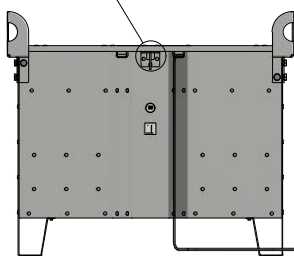
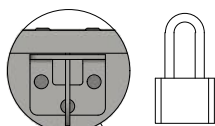
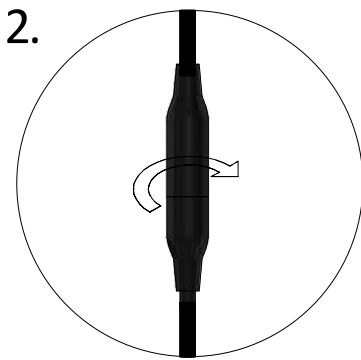
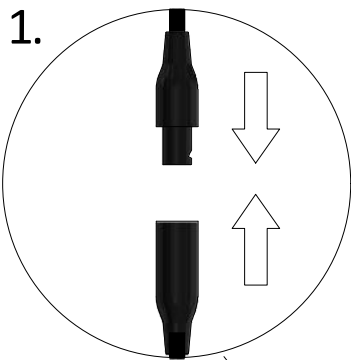
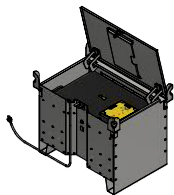

EXTENSION CORD 3 M
9-760-01-040

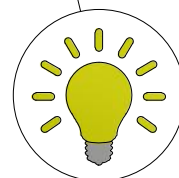
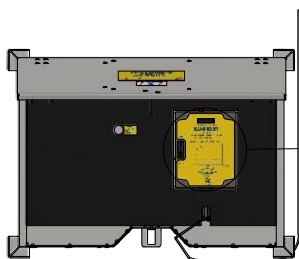
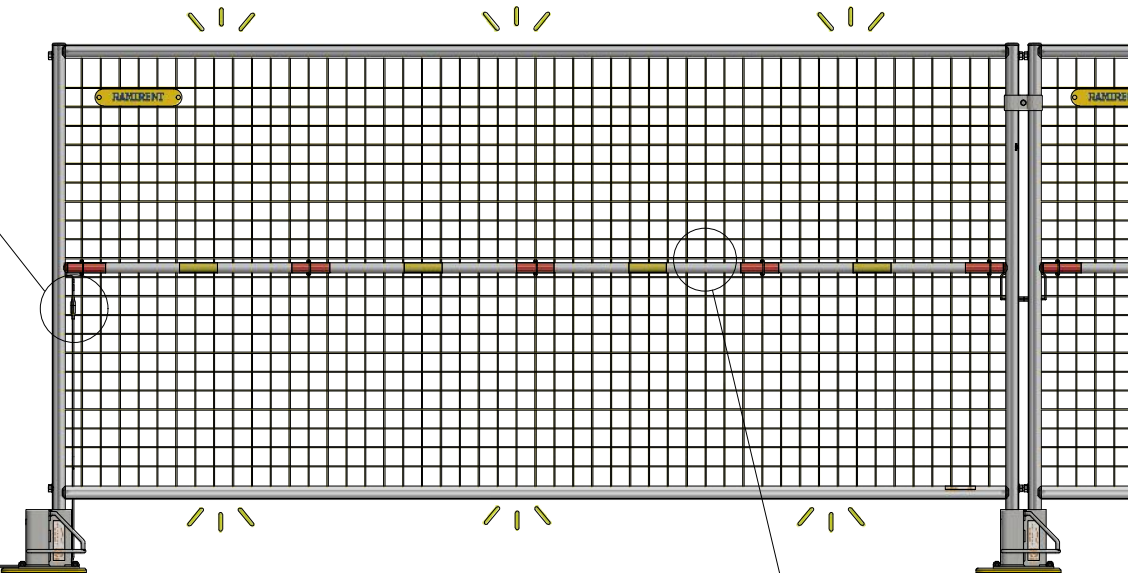

3. ON



BATTERIAGGREGAT/OFF GRID POWER BOX 48V

Kontroll/Check function

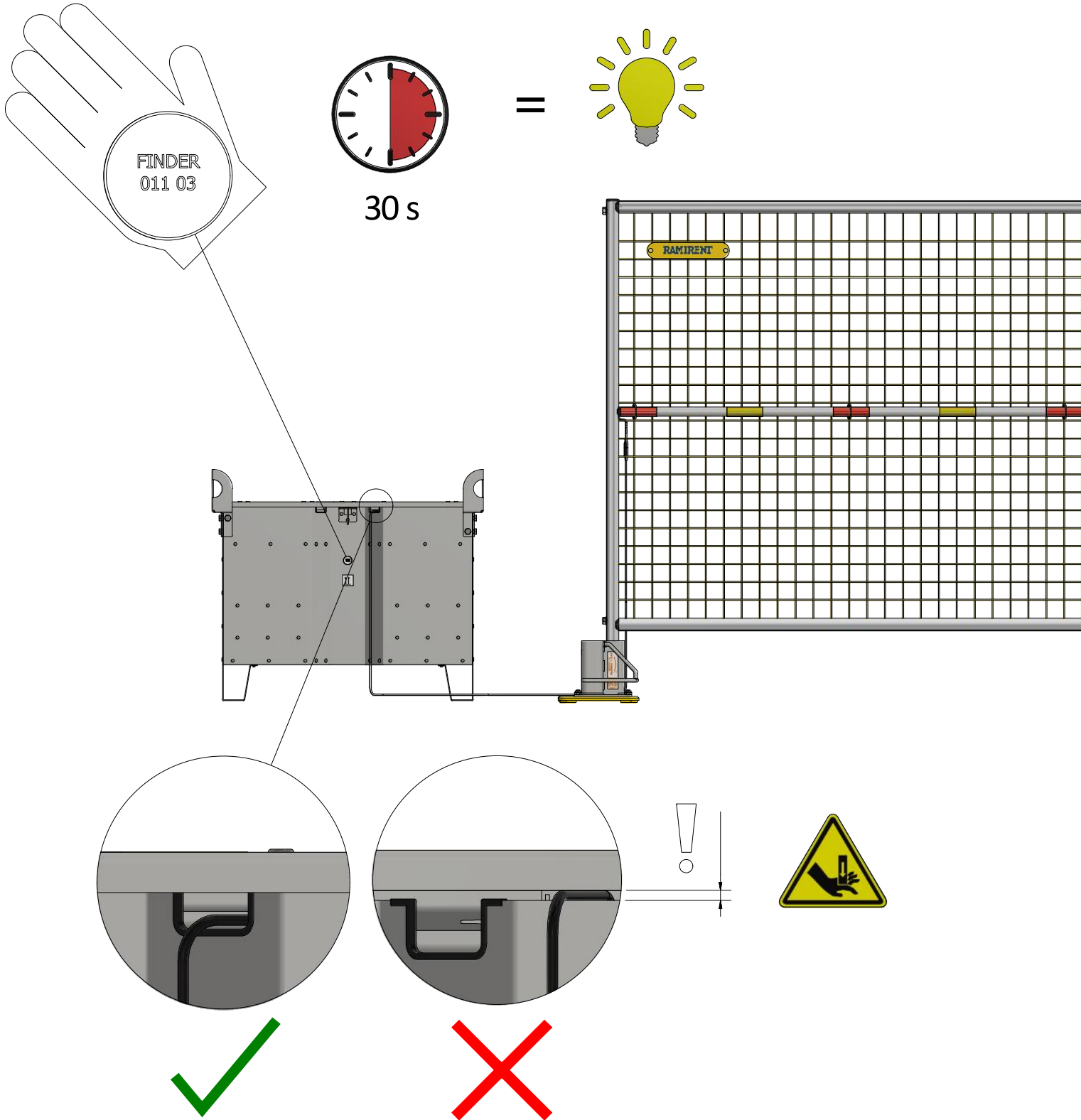

BATTERIAGGREGAT/OFF GRID POWER BOX 48V

Laddning/Charging



Risk för knallgas och frätande syra/syradimma.
Var försiktig med statisk elektricitet./
Risk of oxyhydrogen gas and corrosive acid/acid mist.
Be careful with static electricity.

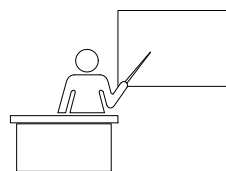

AFS 1988:4

Laddningsplats

Batteriaggregatet ska laddas på en specifik laddningsplats med följande krav:

- God ventilation
- Förbud mot öppen eld och tändkällor så som svetsning, lödning, skärning eller rökning
- Tillgång till ögonsusch
- Tvättmöjligheter
- Brandsläckningsutrustning

Charging area

Off Grid Power Box 48V should be charged to a specific charging area with the following requirements:

- Good ventilation
- Prohibition of open fire and ignition sources such as welding, soldering, cutting or smoking
- Access to eye shower
- Washing facilities
- Fire fighting equipment



1.

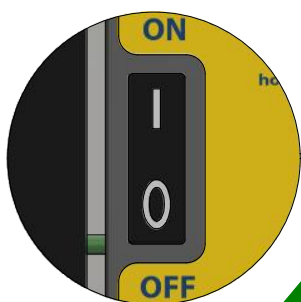

OFF ✓

2.



3.

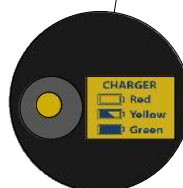
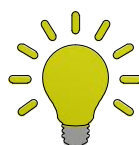

Laddningstid/Charging time: ≈12 h

LAGRING & HANtering/STORAGE & HANDLING

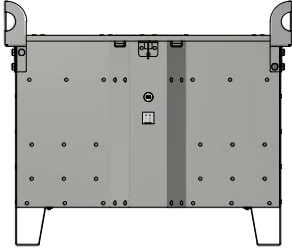

MAX x 1

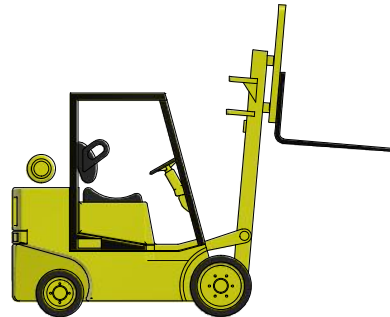
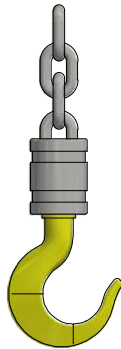
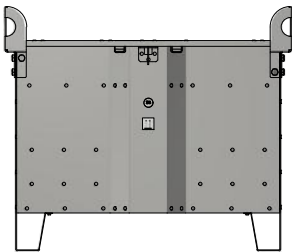

MAX x 3

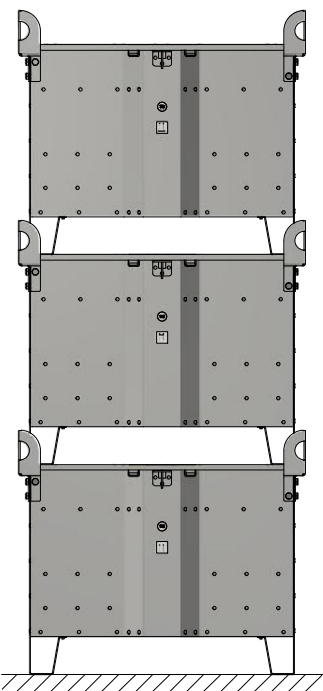

LAGRING & HANtering/STORAGE & HANDLING

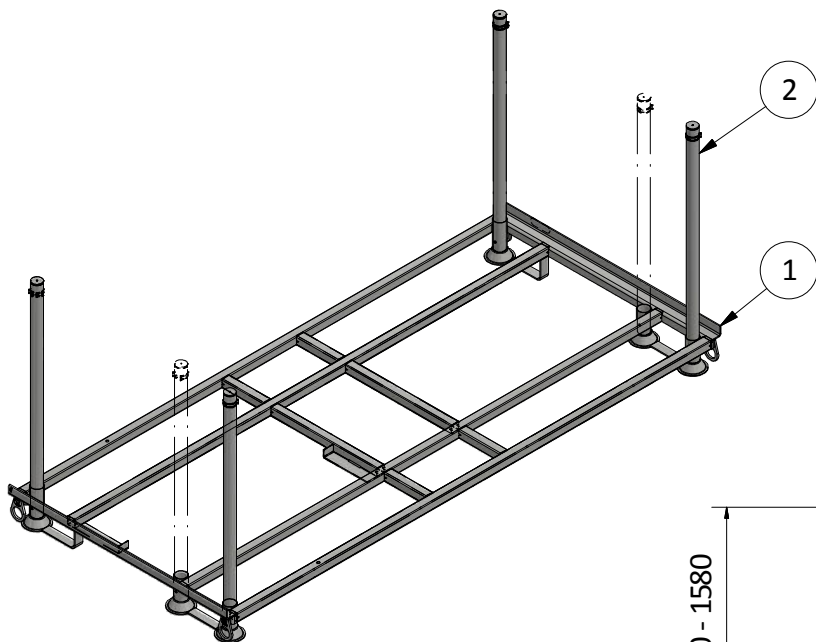

PANEL BOX

9-70-00013

Galvanized

Unpacked weight: 67 kg

Packed weight: 61,8 kg

ITEM	QTY	ART. NO
1	1	9-70-00083
2	4	9-70-000107

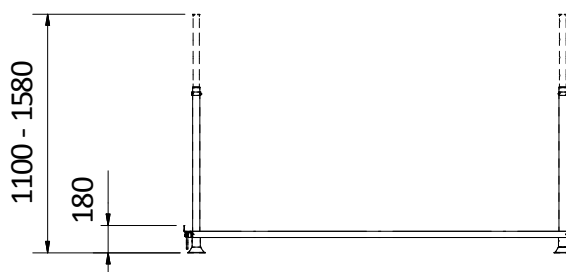

SHIPPING POSITION

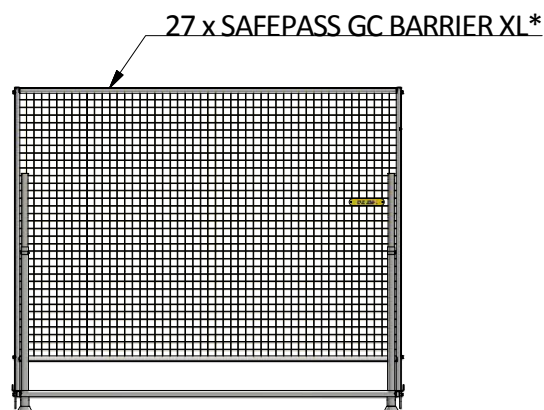
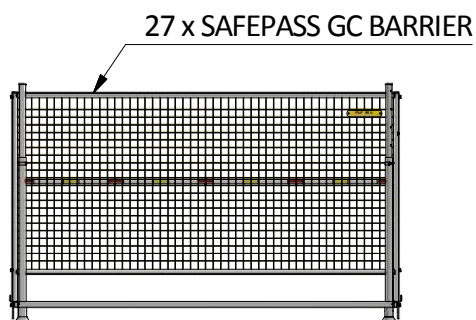
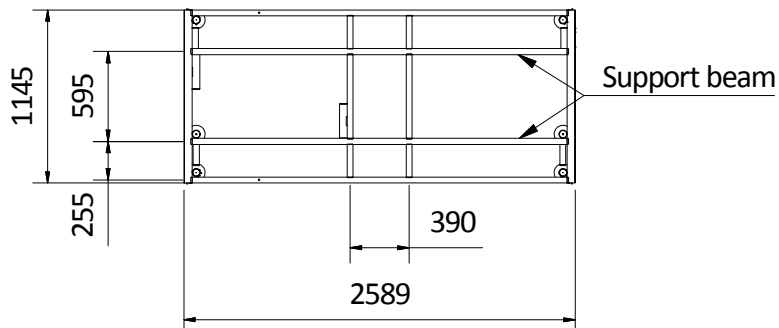
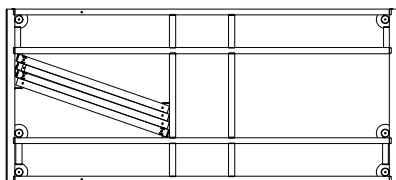

*For the old design of the Panel box with only one support beam applies 20 GC Barrier XL.

LAGRING & HANtering/STORAGE & HANDLING

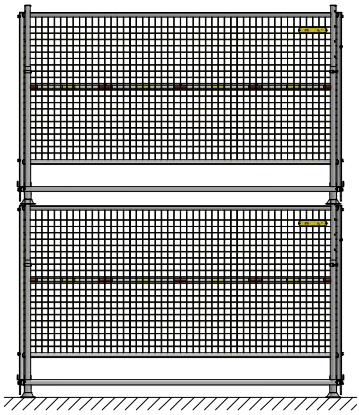

MAX x 2

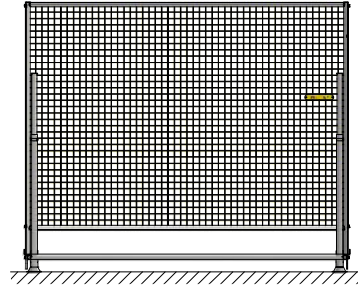
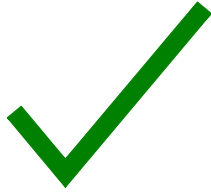

MAX x 1

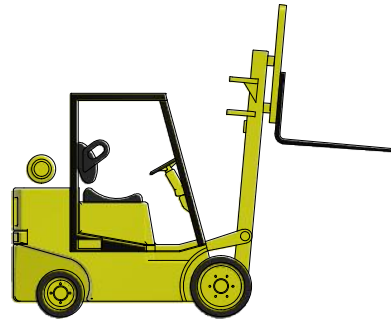
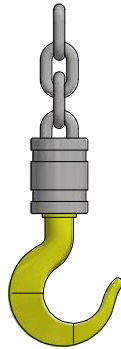
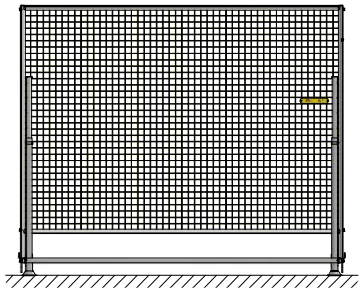
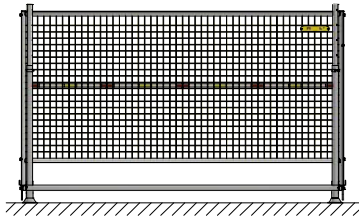

MAX x 1

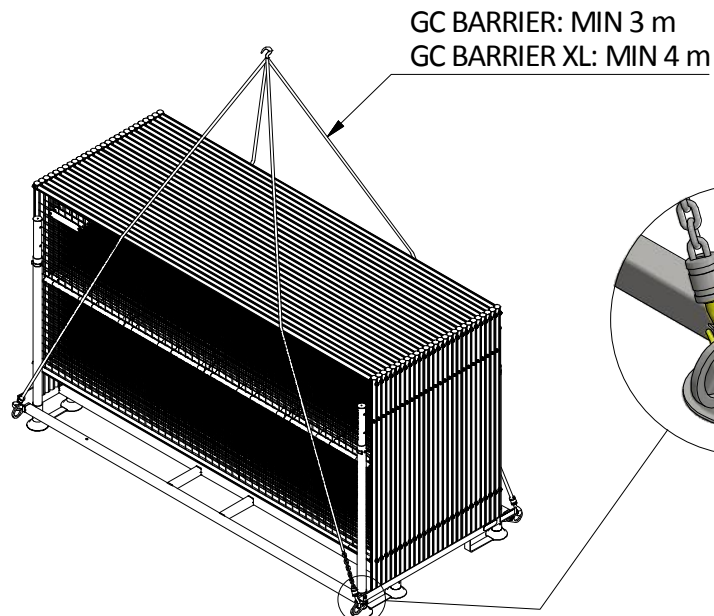

LAGRING & HANtering/STORAGE & HANDLING

GC-RACK/GC-FOOT STORAGE RACK

9-70-000143

Galvanized

Unpacked weight: 67 kg

Packed weight: 570 kg

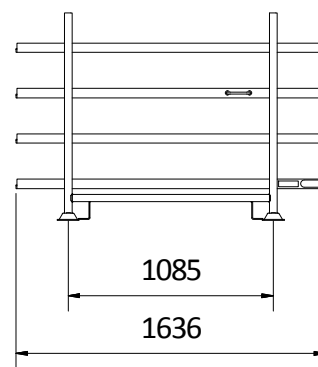
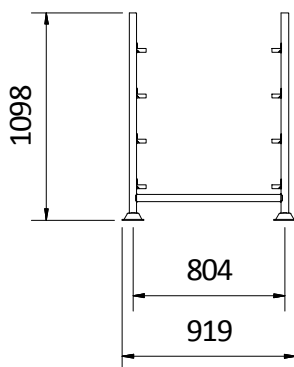
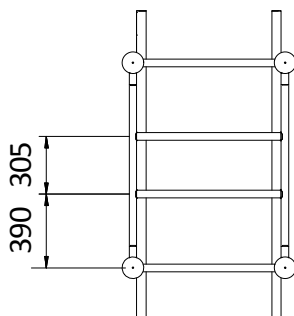
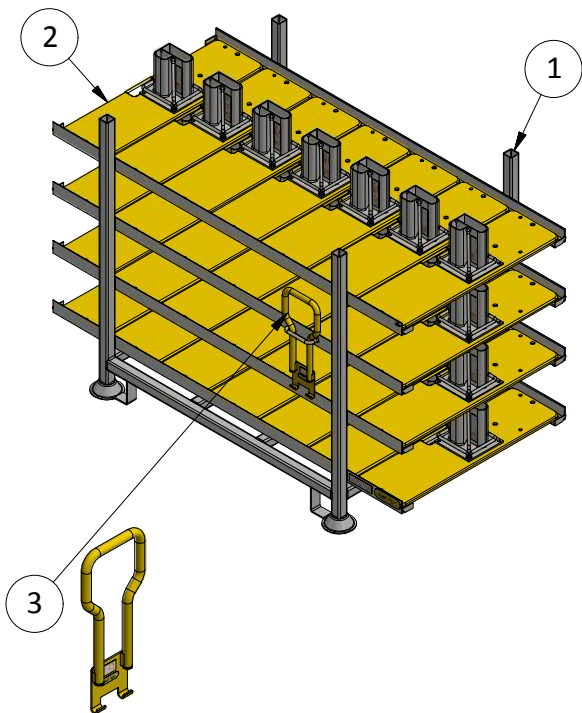

ITEM	QTY	ART. NO
1	1	9-700-00-143
2	28	9-760-01-012
3	2	9-760-01-028

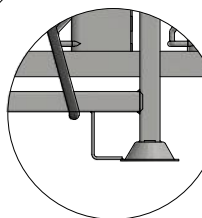
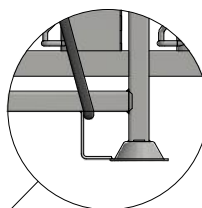
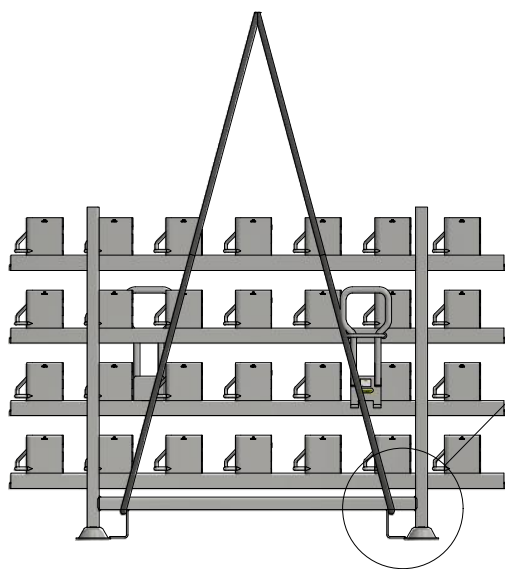
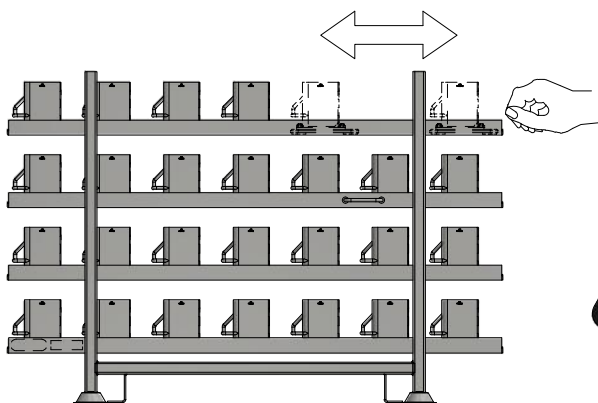

LAGRING & HANtering/STORAGE & HANDLING

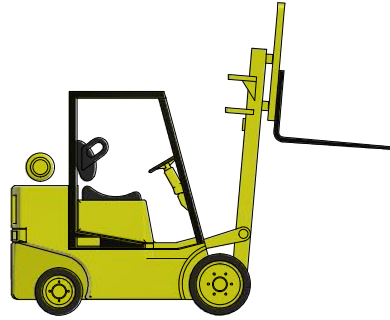
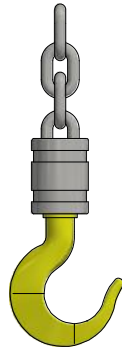
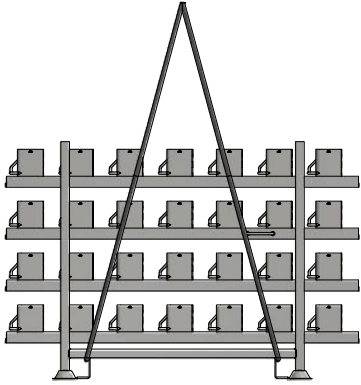

MAX x 1

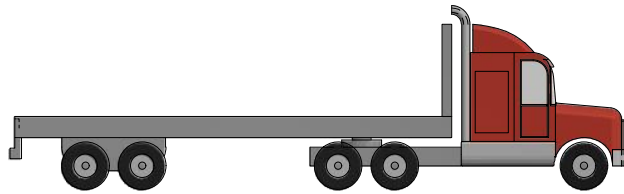
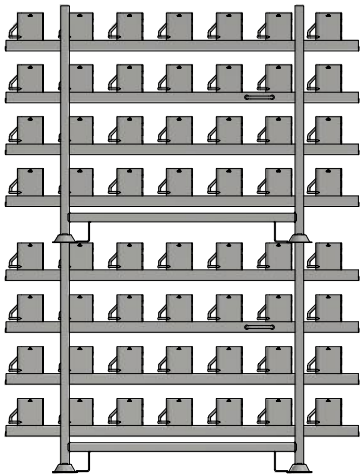
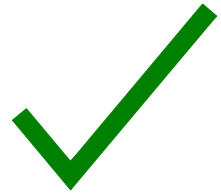

MAX x 2

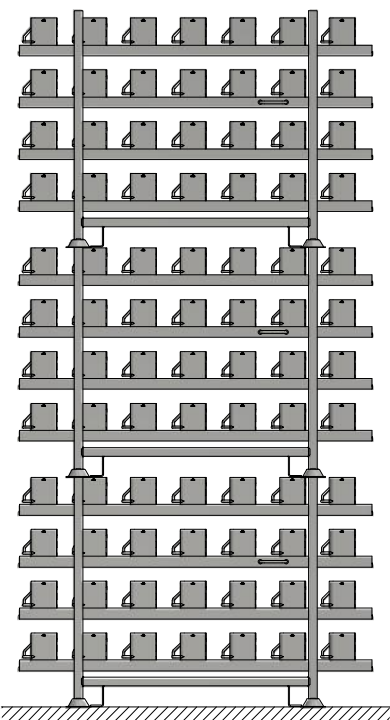
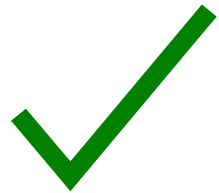

MAX x 3

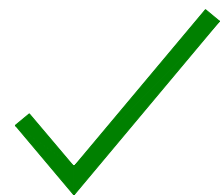

SAFEPASS™ KONTAKT/CONTACT

Teknisk support

Vid frågor, kontakta oss:

Safety Solutions Jonsereds AB
Lägervägen 3
SE-832 96 Frösön
Tel +46 (0)10 498 15 00
jonsereds.com

Technical support

For further information, please contact us:

Safety Solutions Jonsereds AB
Lägervägen 3
SE-832 96 Frösön, SWEDEN
Tel +46 (0)10 498 15 00
jonsereds.com