

Safety and operating instructions

Forward plate

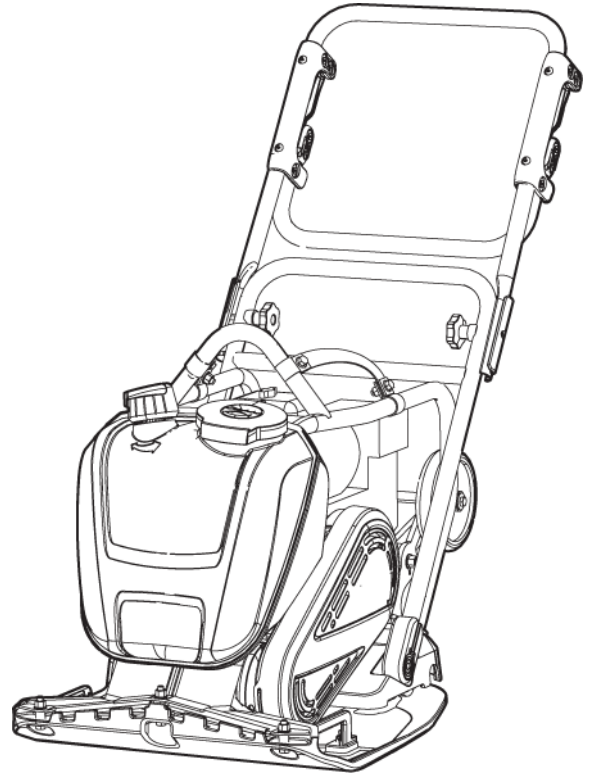

Contents

- Introduction..... 5
- About the Safety and operating instructions..... 5
- Safety instructions..... 6
 - Safety signal words..... 6
 - Personal precautions and qualifications..... 6
 - Personal protective equipment..... 6
 - Drugs, alcohol or medication..... 6
 - Operation, precautions..... 6
 - Transport, precautions..... 10
 - Maintenance, precautions..... 10
 - Storage, precautions..... 10
- Overview..... 11
 - Design and function..... 11
 - Main parts..... 11
 - Labels..... 11
 - Data plate..... 12
 - Noise level label..... 12
 - Lifting point label..... 12
 - Start label..... 13
 - Safety label..... 13
- Transport..... 14
 - Transport wheels..... 14
 - Lifting the machine..... 14
- Installation..... 15
 - Fuel..... 15
 - Filling..... 15
- Operation..... 16
 - Operating near edges..... 16
 - Operating on slopes..... 16
 - Start and stop..... 17
 - Before starting, Honda..... 17
 - Starting the engine, Honda..... 17
 - Stopping the engine, Honda..... 18
 - Operating..... 18
 - Handle positions..... 19
 - When taking a break..... 20
- Maintenance..... 20
 - Every 10 hours of operation (daily)..... 20
 - Checking bolted joint..... 20
 - Checking the engine, Honda..... 20
 - After 20 hours of operation..... 21
 - Changing the engine oil, Honda..... 21
 - Every 100 hours of operation (weekly)..... 21
 - Checking the V-belt..... 21
 - Checking the shock absorbers..... 22
 - Checking spark plug, Honda..... 22
 - Every 500 hours of operation (yearly)..... 22
 - Cleaning the fuel tank..... 23
 - Inspection and adjustment of engine..... 23

Disposal..... 23

Storage..... 23

Technical data..... 24

Machine data..... 24

Weights..... 24

Weights for options..... 24

Noise and vibration declaration statement..... 25

Noise and vibration data..... 25

Uncertainties, sound value..... 25

Dimensions..... 26

EC Declaration of Conformity..... 27

EC Declaration of Conformity (EC Directive 2006/42/EC)..... 27

Introduction

Thank you for choosing a product from Atlas Copco. Since 1873, we have been committed to finding new and better ways of fulfilling our customers' needs. Through the years, we have developed innovative and ergonomic product designs that have helped customers improve and rationalize their daily work.

Atlas Copco has a strong global sales and service network, consisting of customer centers and distributors worldwide. Our experts are highly trained professionals with extensive product knowledge and application experience. In all corners of the world, we can offer product support and expertise to ensure that our customers can work at maximum efficiency at all times.

For more information please visit: www.atlascopco.com

Construction Tools EOOD

7000 Rousse

Bulgaria

About the Safety and operating instructions

The aim of the instructions is to provide you with knowledge of how to use the machine in an efficient, safe way. The instructions also give you advice and tell you how to perform regular maintenance on the machine.

Before using the machine for the first time you must read these instructions carefully and understand all of them.

Safety instructions

To reduce the risk of serious injury or death to yourself or others, read and understand the Safety and operating instruction before installing, operating, repairing, maintaining, or changing accessories on the machine.

Post this Safety and operating instruction at work locations, provide copies to employees, and make sure that everyone reads the Safety and operating instruction before operating or servicing the machine. For professional use only.

In addition, the operator or the operator's employer must assess the specific risks that may be present as a result of each use of the machine.

Additional instructions for the engine can be found in the manufacturer's engine manual.

Safety signal words

The safety signal words Danger, Warning and Caution have the following meanings:

DANGER	Indicates a hazardous situation which, if not avoided, will result in death or serious injury.
WARNING	Indicates a hazardous situation which, if not avoided, could result in death or serious injury.
CAUTION	Indicates a hazardous situation which, if not avoided, could result in minor or moderate injury.

Personal precautions and qualifications

Only qualified and trained persons may operate or maintain the machine. They must be physically able to handle the bulk, weight, and power of the machine. Always use your common sense and good judgement.

Personal protective equipment

Always use approved protective equipment. Operators and all other persons in the working area must wear protective equipment, including at a minimum:

- Protective helmet
- Hearing protection
- Impact resistant eye protection with side protection
- Respiratory protection when appropriate
- Protective gloves
- Proper protective boots

- Appropriate work overall or similar clothing (not loose-fitting) that covers your arms and legs.

Drugs, alcohol or medication

▲ **WARNING** Drugs, alcohol or medication

Drugs, alcohol or medication may impair your judgment and powers of concentration. Poor reactions and incorrect assessments can lead to severe accidents or death.

- ▶ Never use the machine when you are tired or under the influence of drugs, alcohol or medication.
- ▶ No person who is under the influence of drugs, alcohol or medication may operate the machine.

Operation, precautions

▲ **DANGER** Explosion hazard

If a warm machine or exhaust pipe comes into contact with explosives, an explosion could occur. During operating with certain materials, sparks and ignition can occur. Explosions will lead to severe injuries or death.

- ▶ Never operate the machine in any explosive environment.
- ▶ Never use the machine near flammable materials, fumes or dust.
- ▶ Make sure that there are no undetected sources of gas or explosives.
- ▶ Avoid contact with the warm exhaust pipe or the bottom of the machine.

▲ **DANGER** Fire hazard

If a fire starts in the machine, it can cause injury.

- ▶ If possible use an ABE-class powder extinguisher, otherwise use a BE-type carbon dioxide fire extinguisher.

▲ **DANGER** Fuel hazard

The fuel is flammable and fuel fumes can explode when ignited, causing serious injury or death.

- ▶ Protect your skin from contact with the fuel. If fuel has penetrated the skin, consult a qualified health professional.
- ▶ Never remove the filler cap, or fill the fuel tank when the machine is hot.
- ▶ Fill the fuel tank outdoors or in a clean and well ventilated place, free from sparks and open flames. Fill the fuel tank at least ten meters (30 feet) from the place where the machine is to be used.

- ▶ Release the filler cap slowly to let pressure escape.
- ▶ Never overfill the fuel tank.
- ▶ Make sure the filler cap is screwed on when the machine is used.
- ▶ Avoid spilling fuel on the machine, wipe off any spilled fuel.
- ▶ Check regularly for fuel leaks. Never use the machine if it is leaking fuel.
- ▶ Never use the machine in the proximity of material that can generate sparks. Remove all hot or spark-generating devices before starting the machine.
- ▶ Never smoke when filling the fuel tank or when working with the machine or servicing it.
- ▶ Only store fuel in a container that is specially constructed and approved for the purpose.
- ▶ Consumed fuel and oil containers must be taken care of and returned to the retailer.
- ▶ Never use your fingers to check for fluid leaks.

▲ WARNING Unexpected movements

The machine is exposed to heavy strains during operation. If the machine breaks or gets stuck, there may be sudden and unexpected movement that can cause injuries.

- ▶ Always inspect the machine prior to use. Never use the machine if you suspect that it is damaged.
- ▶ Make sure that the handle is clean and free of grease and oil.
- ▶ Keep your feet away from the machine.
- ▶ Never sit on the machine.
- ▶ Never strike or abuse the machine.
- ▶ Pay attention and look at what you are doing.

▲ WARNING Dust and fume hazard

Dusts and/or fumes generated or dispersed when using the machine may cause serious and permanent respiratory disease, illness, or other bodily injury (for example, silicosis or other irreversible lung disease that can be fatal, cancer, birth defects, and/or skin inflammation).

Some dusts and fumes created by compaction work contain substances known to the State of California and other authorities to cause respiratory disease, cancer, birth defects, or other reproductive harm.

Some examples of such substances are:

- Crystalline silica, cement, and other masonry products.
- Arsenic and chromium from chemically-treated rubber.
- Lead from lead-based paints.

Dust and fumes in the air can be invisible to the naked eye, so do not rely on eye sight to determine if there is dust or fumes in the air.

To reduce the risk of exposure to dust and fumes, do all of the following:

- ▶ Perform site-specific risk assessment. The risk assessment must include dust and fumes created by the use of the machine and the potential for disturbing existing dust.
- ▶ Use proper engineering controls to minimize the amount of dust and fumes in the air and to minimize build-up on equipment, surfaces, clothing, and body parts. Examples of controls include: exhaust ventilation and dust collection systems, water sprays, and wet drilling. Control dusts and fumes at the source where possible. Make sure that controls are properly installed, maintained and correctly used.
- ▶ Wear, maintain and correctly use respiratory protection as instructed by your employer and as required by occupational health and safety regulations. The respiratory protection must be effective for the type of substance at issue (and if applicable, approved by relevant governmental authority).
- ▶ Work in a well ventilated area.
- ▶ If the machine has an exhaust, direct the exhaust so as to reduce disturbance of dust in a dust filled environment.
- ▶ Operate and maintain the machine as recommended in the operating and safety instructions
- ▶ Wear washable or disposable protective clothes at the worksite, and shower and change into clean clothes before leaving the worksite to reduce exposure of dust and fumes to yourself, other persons, cars, homes, and other areas.

- ▶ Avoid eating, drinking, and using tobacco products in areas where there is dust or fumes.
- ▶ Wash your hands and face thoroughly as soon as possible upon leaving the exposure area, and always before eating, drinking, using tobacco products, or making contact with other persons.
- ▶ Comply with all applicable laws and regulations, including occupational health and safety regulations.
- ▶ Participate in air monitoring, medical examination programs, and health and safety training programs provided by your employer or trade organizations and in accordance with occupational health and safety regulations and recommendations. Consult with physicians experienced in relevant occupational medicine.
- ▶ Work with your employer and trade organization to reduce dust and fume exposure at the worksite and to reduce the risks. Effective health and safety programs, policies and procedures for protecting workers and others against harmful exposure to dust and fumes must be established and implemented based on advice from health and safety experts. Consult with experts.

▲ DANGER Exhaust gas hazard

The exhaust gas from the machine's combustion engine contains carbon monoxide which is poisonous, and chemicals known to the State of California and other authorities to cause cancer, birth defects, or other reproductive harm. Inhalation of exhaust fumes can cause serious injury, illness, or death.

- ▶ Never inhale exhaust fumes.
- ▶ Ensure good ventilation (extraction of air by fan if necessary).

▲ WARNING Projectiles

Failure of the work piece, of accessories, or even of the machine itself may generate high velocity projectiles. During operating, splinters or other particles from the compacted material may become projectiles and cause personal injury by striking the operator or other persons. To reduce these risk:

- ▶ Use approved personal protective equipment and safety helmet, including impact resistant eye protection with side protection.
- ▶ Make sure that no unauthorised persons trespass into the working zone.
- ▶ Keep the workplace free from foreign objects.

▲ WARNING Slope hazards

During operation, secure the machine so it can not fall if it is placed on a sloping ground. A fall can lead to severe accidents and result in personal injury.

- ▶ Always ensure that all personnel in the working area are higher up the slope than the machine.
- ▶ Always operate the machine straight up and down when placed on slopes.
- ▶ Never exceed the maximum recommended slope angle when operating the machine. Follow the recommendations.

▲ WARNING Motion hazards

When using the machine to perform work-related activities, you may experience discomfort in the hands, arms, shoulders, neck, or other parts of the body.

- ▶ Adopt a comfortable posture while maintaining secure footing and avoiding awkward off-balanced postures.
- ▶ Changing posture during extended tasks may help avoid discomfort and fatigue.
- ▶ In case of persistent or recurring symptoms, consult a qualified health professional.

▲ WARNING Vibration hazards

Normal and proper use of the machine exposes the operator to vibration. Regular and frequent exposure to vibration may cause, contribute to, or aggravate injury or disorders to the operator's fingers, hands, wrists, arms, shoulders and/or nerves and blood supply or other body parts, including debilitating and/or permanent injuries or disorders that may develop gradually over periods of weeks, months, or years. Such injuries or disorders may include damage to the blood circulatory system, damage to the nervous system, damage to joints, and possibly damage to other body structures.

If numbness, persistent recurring discomfort, burning sensation, stiffness, throbbing, tingling, pain, clumsiness, weakened grip, whitening of the skin, or other symptoms occur at any time, when operating the machine or when not operating the machine, stop operating the machine, tell your employer and seek medical attention. Continued use of the machine after the occurrence of any such symptom may increase the risk of symptoms becoming more severe and/or permanent.

Operate and maintain the machine as recommended in these instructions, to prevent an unnecessary increase in vibration.

The following may help to reduce exposure to vibration for the operator:

- ▶ If the machine has vibration absorbing handles, keep them in a central position, avoid pressing the handles into the end stops.
- ▶ When the percussion mechanism is activated, the only body contact with the machine you must have are your hands on the handle or handles. Avoid any other contact, for example supporting any part of the body against the machine or leaning onto the machine trying to increase the feed force.
- ▶ Make sure that the machine is well-maintained and not worn out.
- ▶ Immediately stop working if the machine suddenly starts to vibrate strongly. Before resuming the work, find and remove the cause of the increased vibrations.
- ▶ Participate in health surveillance or monitoring, medical exams and training programs offered by your employer and when required by law.
- ▶ When working in cold conditions wear warm clothing and keep hands warm and dry.

See the "Noise and vibration declaration statement" for the machine, including the declared vibration values. This information can be found at the end of these Safety and operating instructions.

▲ WARNING Trapping hazard

There is a risk of neck ware, hair, gloves, and clothes getting dragged into or caught by rotating machine parts. This may cause choking, scalping, lacerations, or death. To reduce the risk:

- ▶ Never grab or touch a rotating machine part.
- ▶ Avoid wearing clothing, neck ware or gloves that may get caught.
- ▶ Cover long hair with a hair net.

▲ DANGER Electrical hazard

The machine is not electrically insulated. If the machine comes into contact with electricity, serious injuries or death may result.

- ▶ Never operate the machine near any electric wire or other source of electricity.
- ▶ Make sure that there are no concealed wires or other sources of electricity in the working area.

▲ WARNING Concealed object hazard

During operating, concealed wires and pipes constitute a danger that can result in serious injury.

- ▶ Check the composition of the material before operating.
- ▶ Watch out for concealed cables and pipes for example electricity, telephone, water, gas, and sewage lines.
- ▶ If the machine seems to have hit a concealed object, switch off the machine immediately.
- ▶ Make sure that there is no danger before continuing.

▲ WARNING Involuntary start

Involuntary start of the machine may cause injury.

- ▶ Keep your hands away from the start and stop device until you are ready to start the machine.
- ▶ Learn how the machine is switched off in the event of an emergency.

▲ WARNING Noise hazard

High noise levels can cause permanent and disabling hearing loss and other problems such as tinnitus (ringing, buzzing, whistling, or humming in the ears). To reduce risks and prevent an unnecessary increase in noise levels:

- ▶ Risk assessment of these hazards and implementation of appropriate controls is essential.
- ▶ Operate and maintain the machine as recommended in these instructions.
- ▶ If the machine has a silencer, check that it is in place and in good working condition.
- ▶ Always use hearing protection.

Transport, precautions

▲ WARNING Loading and unloading hazard

When the machine is lifted by a crane and similar appliance, this can lead to injury.

- ▶ Use marked lifting points.
- ▶ Make sure that all lifting devices are dimensioned for the weight of the machine.
- ▶ Never remain under or in the immediate vicinity of the machine.

Maintenance, precautions

▲ WARNING Machine modification

Any machine modification may result in bodily injuries to yourself or others.

- ▶ Never modify the machine. Modified machines are not covered by warranty or product liability.
- ▶ Always use original parts, cutting blades/working tools, and accessories.
- ▶ Change damaged parts immediately.
- ▶ Replace worn components in good time.

▲ CAUTION High temperature

The machine's engine exhaust pipe, and bottom become hot during operation. Touching them can lead to burns.

- ▶ Never touch a hot machine.
- ▶ Never touch the bottom of the machine when its hot.
- ▶ Wait until the engine, exhaust pipe, and bottom of the machine have cooled down before carrying out maintenance work.

Storage, precautions

- ◆ Keep the machine in a safe place, out of the reach of children and locked up.

Overview

To reduce the risk of serious injury or death to yourself or others, read the Safety instructions section found on the previous pages of this manual before operating the machine.

Design and function

LF compacters are specially designed for compacting thin to medium layers of granular soils and, with the added water tank, for asphalt. They are ideal for repair jobs and maintenance work such as driveways, pathways, and parking lots. With a block paving kit they are also suitable for block paving applications. No other use is permitted.

LF compacters must only be used in well-ventilated areas, as is the case for all combustion engine machines.

Do not tow the machine behind vehicles.

To choose the correct accessories, see the spare parts list.

For professional use only.

NOTICE Avoid mixing diesel or other toxic substances in the water tank, this can damage the machine and have negative influence on the environment.

Main parts

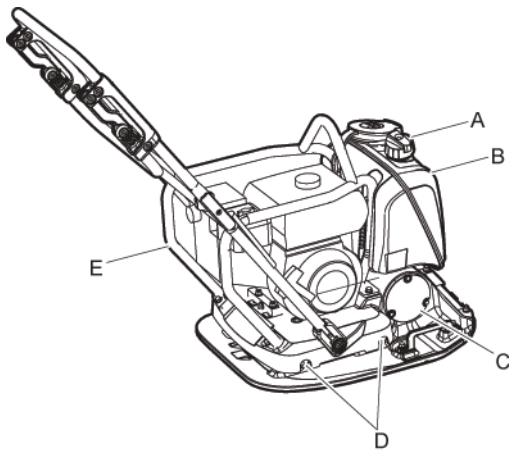

- A. Water valve
- B. Water tank
- C. Eccentric element
- D. Shock absorbers

- E. Protection frame



- F. V-belt

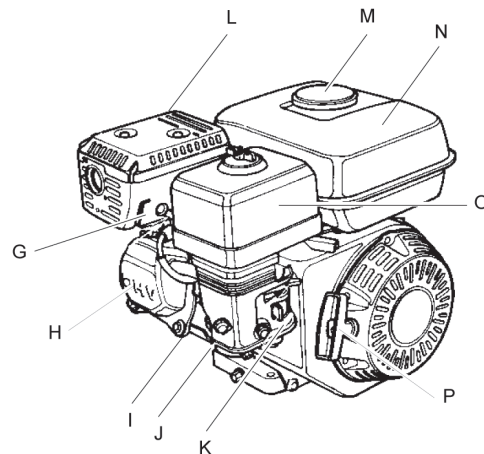

- G. Spark plug
- H. Engine valves
- I. Cooling flanges
- J. Engine oil/dipstick
- K. Carburettor
- L. Silencer
- M. Fuel cap
- N. Fuel tank
- O. Air filter
- P. Recoil starter

Labels

The machine is fitted with labels containing important information about personal safety and machine maintenance. The labels must be in such condition that they are easy to read. New labels can be ordered from the spare parts list.

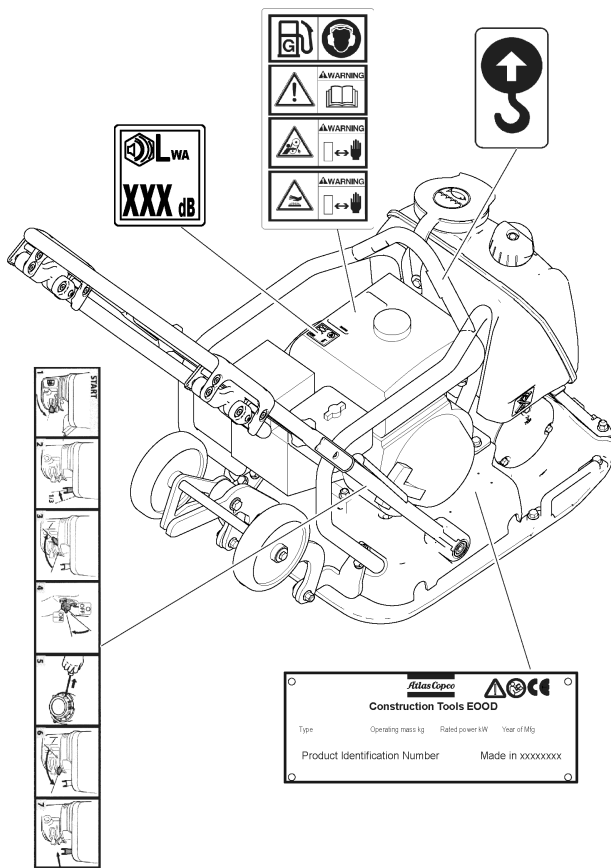

Noise level label

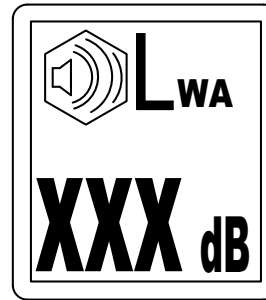

The label indicates the guaranteed noise level corresponding to EC-directive 2000/14/EC. See "Technical data" for accurate noise level.

Lifting point label

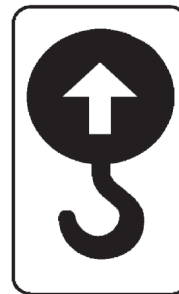

Data plate

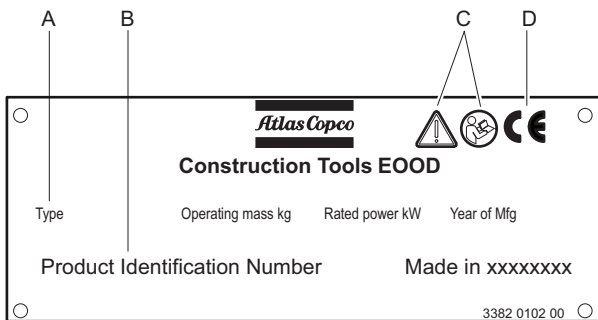

- A. Machine type
- B. Product Identification Number
- C. The warning symbol together with the book symbol means that the user must read the safety and operating instructions before the machine is used for the first time.
- D. The CE symbol means that the machine is EC-approved. See the EC Declaration of Conformity which is delivered with the machine for more information.

Start label



Safety label

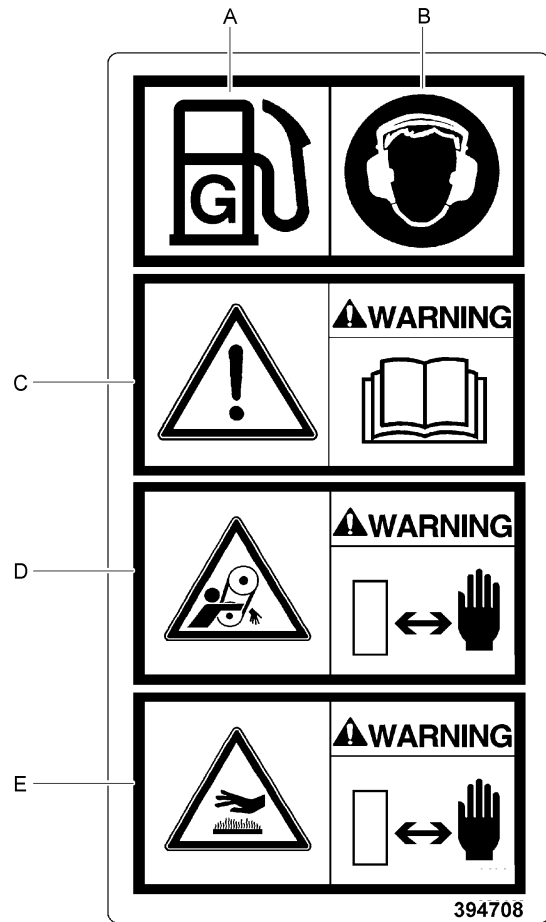

- A. Fuel.
- B. Use ear protectors.
- C. Read the instruction manual. The operator must read the safety, operation and maintenance instructions before operating the machine.
- D. Warning! Cutting hazards.
- E. Warning! Hot surfaces in the engine compartment. Keep hands at a safe distance from the danger zone.

Transport

Transport wheels

1. Unlock the hook (A).

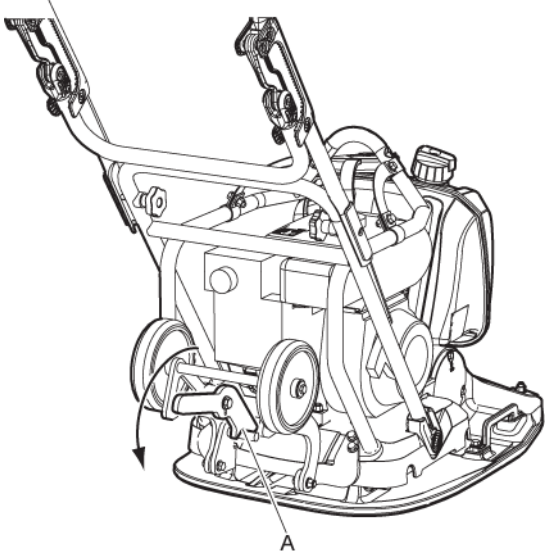

2. Fold the wheels (B) in under the bottom plate to facilitate manual transport.

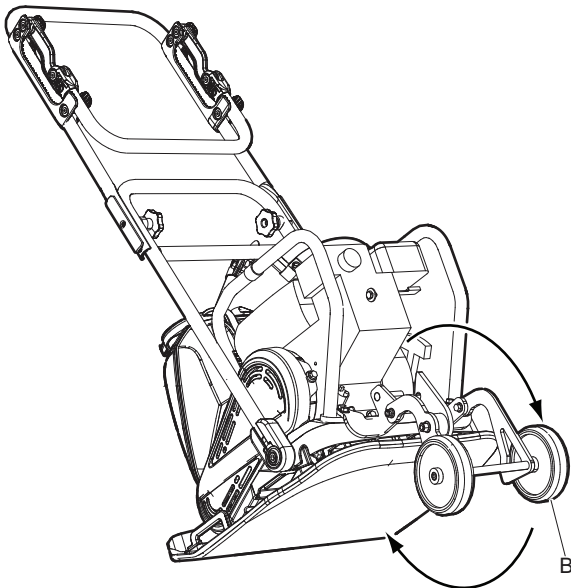

Lifting the machine

▲ WARNING Lifting hazard

Never lift the machine without checking if it is intact. A damaged machine can fall apart, which can result in serious injury.

- ▶ Check that all equipment is dimensioned in accordance with applicable regulations.
- ▶ Never walk or stand under a lifted machine.
- ▶ Only lift the machine by a hook on the frame.
- ▶ Check that the shock absorbers and safety frame are correctly attached and not damaged.
- ▶ Never stand near the machine or forklift truck when lifting and transporting the machine.
- ▶ Check the machine's data plate for weight information.

Lifting

- ◆ Always use the machine's safety frame lifting point (A) to lift the machine.

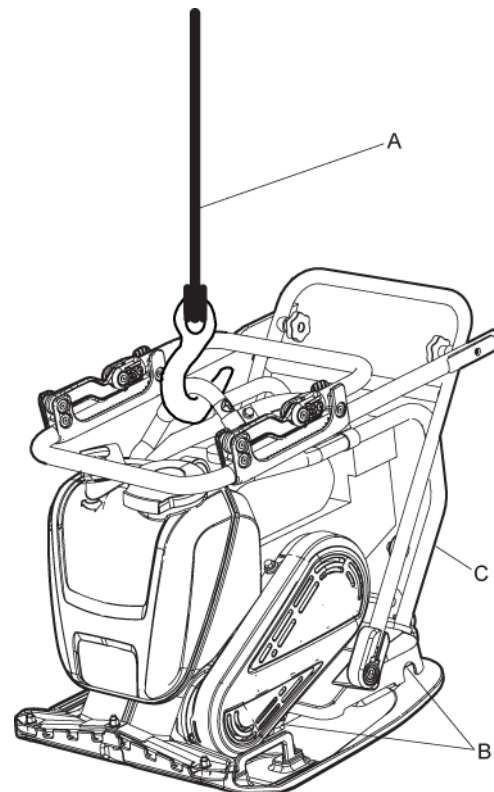

- ◆ Lifting equipment must be dimensioned in order to fulfil all regulations.
- ◆ Before lifting check that the shock absorbers (B) and safety frame (C) are correctly attached and not damaged.

Lifting with forklift truck

- ◆ Both straps (D) must be used when lifting the machine with forklift truck (E).

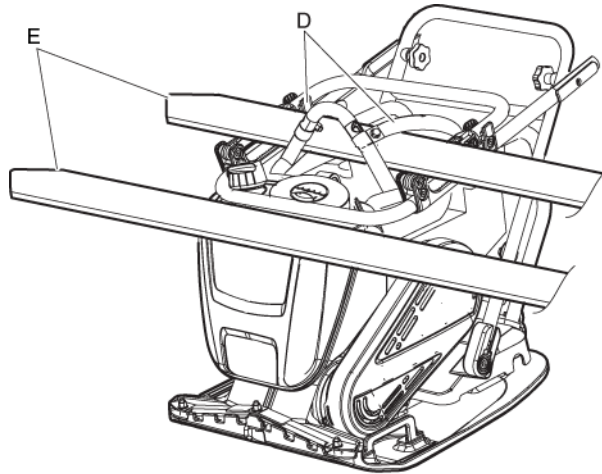

▲ WARNING Transport

During transportation the machine can overturn and cause serious injury.

- ▶ Always strap the machine down.
- ▶ Keep your feet away from the machine.

Transporting the machine

1. Secure the machine for all transportation.
2. Place lashing straps (A) in U-shape around the bottom plate and secure both front and rear.

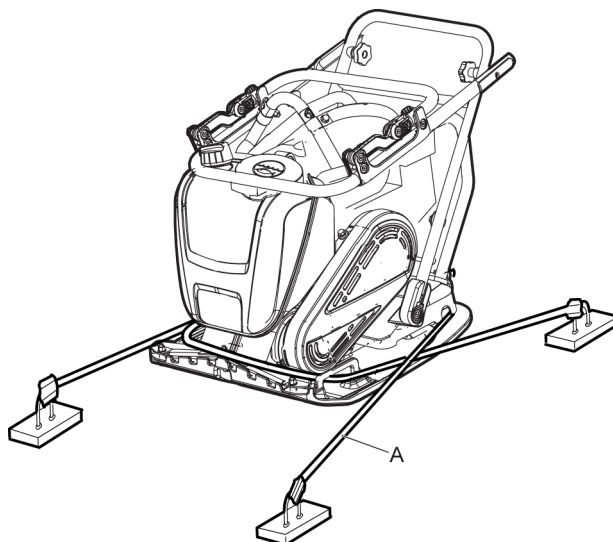

Installation

Fuel

Filling

▲ WARNING Fuel hazard

The fuel is extremely flammable and fuel fumes can explode when ignited, causing serious injury or death.

- ▶ Protect your skin from contact with the fuel.
- ▶ Never remove the filler cap or fill the fuel tank when the machine is hot.
- ▶ Never smoke when filling the fuel tank or when working with the machine or servicing it.
- ▶ Avoid spilling fuel and wipe off any fuel spilled on the machine.

Filling procedure

1. Stop the engine and let it cool down before filling the tank.
2. Release the filler cap slowly to let any pressure escape.
3. Fill the fuel tank to the lower edge of the filler pipe.

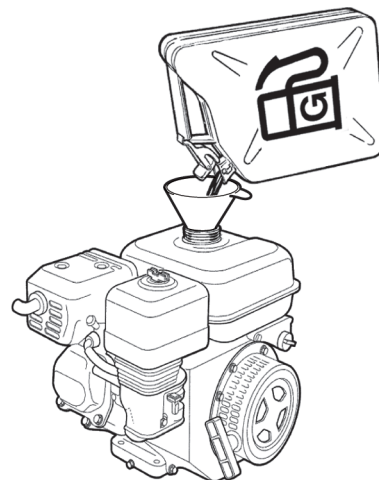

4. Never overfill the tank. Due to the movement of the fuel within the tank, it is possible to have fuel at a higher level than the tank cap, which can lead to a spillage of fuel if the tank cap is opened. This can be avoided by only opening the tank cap when the machine is on level ground and the tank cap is at the fuel tank's highest point.

Operation

▲ **WARNING Engine running hazard**

Vibrations from the engine can cause material changes, this can cause the machine to move and cause injuries.

- ▶ Never leave the machine with the engine running.
- ▶ Ensure that only authorized personnel operate the machine.

NOTICE When operating the machine, follow the instructions in the manual; never sit or stand on the machine when it is working.

Operating near edges

▲ **WARNING Overturning hazard**

When operating along edges, at least $\frac{2}{3}$ of the machine must be on a surface with full bearing strength, otherwise the machine can tip over.

- ▶ Switch off the machine and lift it back on surface with full bearing strength.

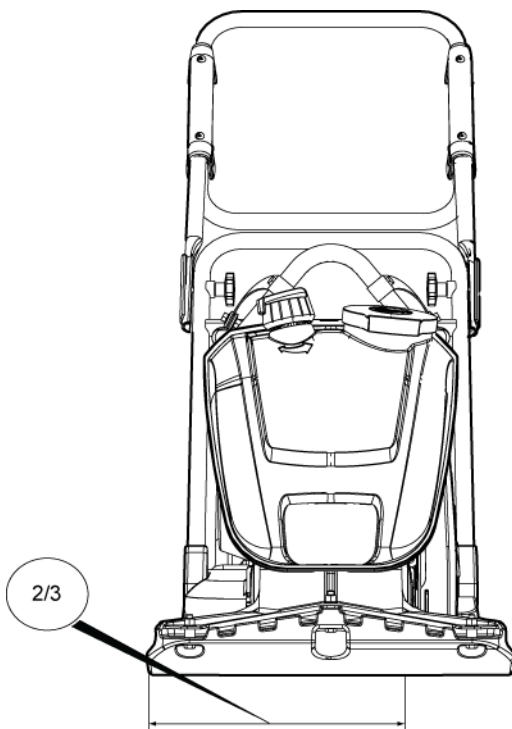

Operating on slopes

▲ **WARNING Slope hazards**

During operation, secure the machine so it can not fall if it is placed on a sloping ground. A fall can lead to severe accidents and result in personal injury.

- ▶ Always ensure that all personnel in the working area are higher up the slope than the machine.
- ▶ Always operate the machine straight up and down when placed on slopes.
- ▶ Never exceed the maximum recommended slope angle when operating the machine. Follow the recommendations.

NOTICE Remember that loose ground, vibration switched ON, and driving speed can all cause the machine to tip over even on a lesser slope than specified here.

Operating on slopes

- ◆ Ensure that the work area is secure. Wet and loose earth reduces manoeuvrability especially on sloping ground. Always exercise extreme caution on sloping and uneven terrain.
- ◆ Never work on slopes that exceed the capabilities of the machine. The maximum slope of the machine in operation is 20° (depending on the condition of the ground).

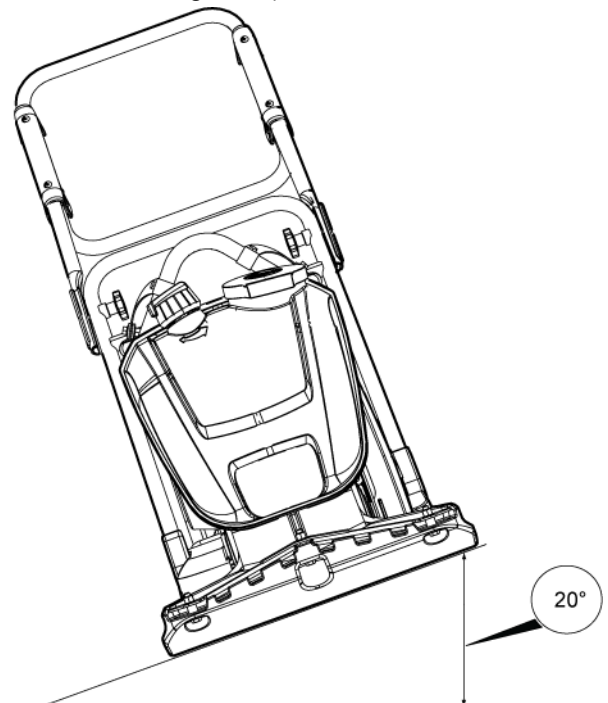

- ◆ The tilting angle is measured on a hard level surface with the machine stationary. Vibration switched OFF and all tanks full.

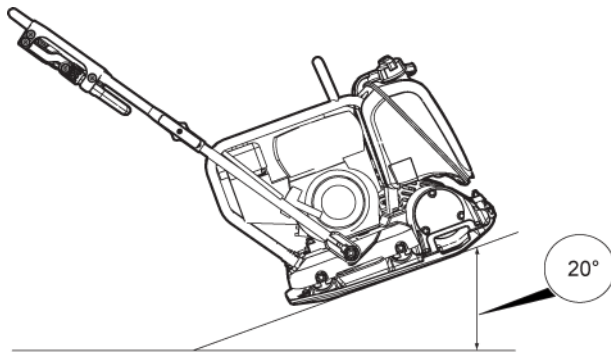

Start and stop

Before starting, Honda

Follow the general safety precautions supplied with the machine at delivery. We recommend to study the engine manual supplied with the machine. Check that maintenance routines have been carried out.

- ◆ Check the engine oil level on the dipstick.

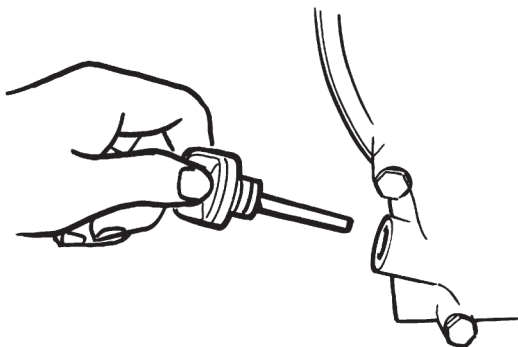

- ◆ Fill the fuel tank with fuel.

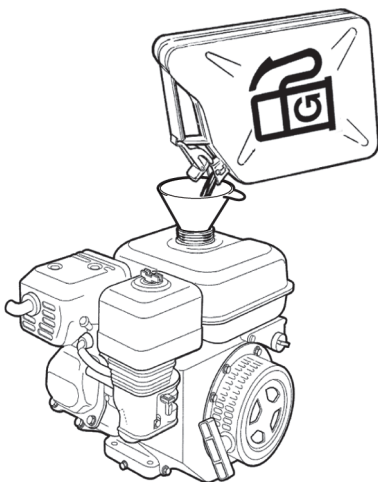

- ◆ Check that all the controls are working.

- ◆ Make sure that there is no oil leakage, and that all bolted joints are tightened.
- ◆ After the engine is started, leave the speed control in the idling position for a few minutes to warm up the engine without loading it.

Starting the engine, Honda

1. Open the fuel cock (A).

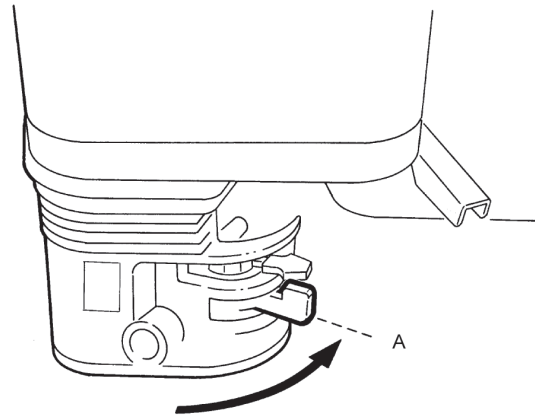

2. Set the throttle control (B) to 1/3 throttle.

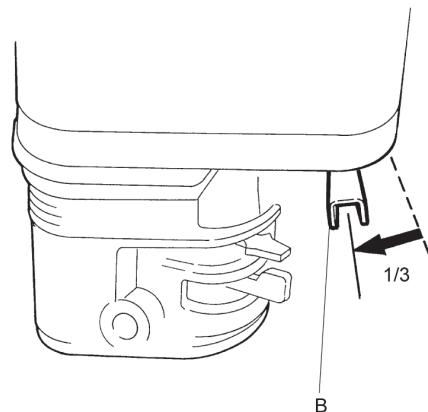

3. Close the choke valve (C) if the engine is cold. If the engine is warm or the ambient temperature is high, close the choke valve halfway or leave it open.

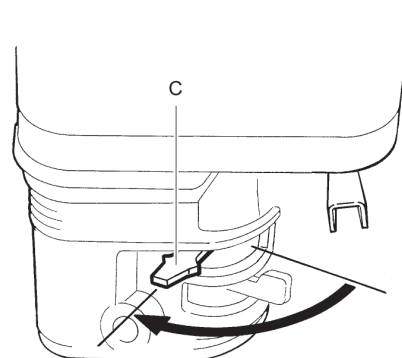

- Turn the start switch (D) to ON.

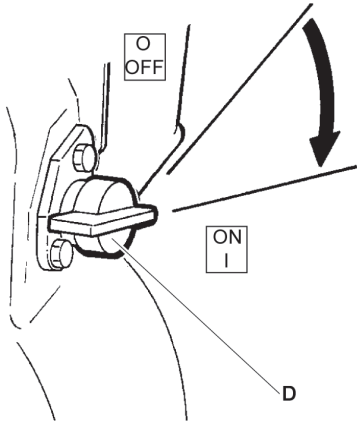

- Grip the handle of the recoil starter (E) and pull until resistance is felt. Release the handle to the initial position, then pull until the engine starts.

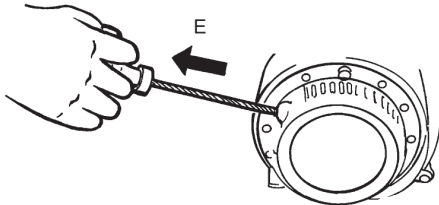

- Move the choke valve (F) gradually to the fully open position.

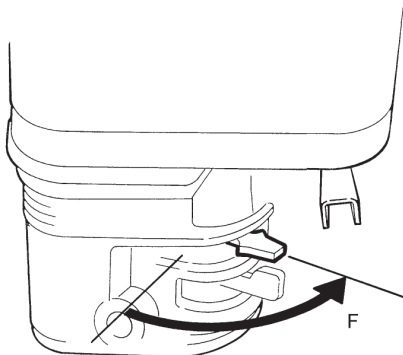

- Allow the engine to idle a few minutes before increasing to full power (G).

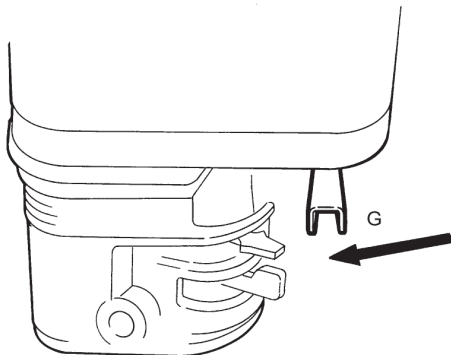

Stopping the engine, Honda

- Move the throttle control to idling position (A). Let the engine idle for a few minutes.

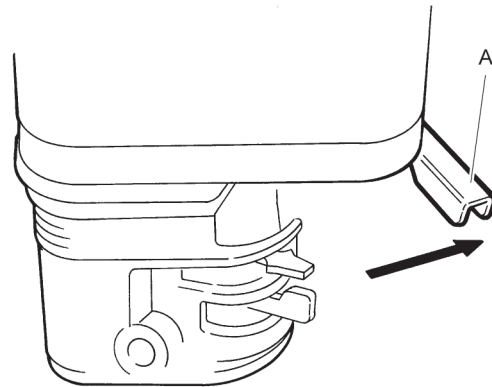

- Turn the start switch (B) to OFF.

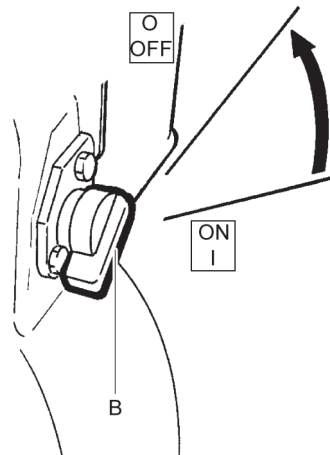

- Close the fuel cock (C).

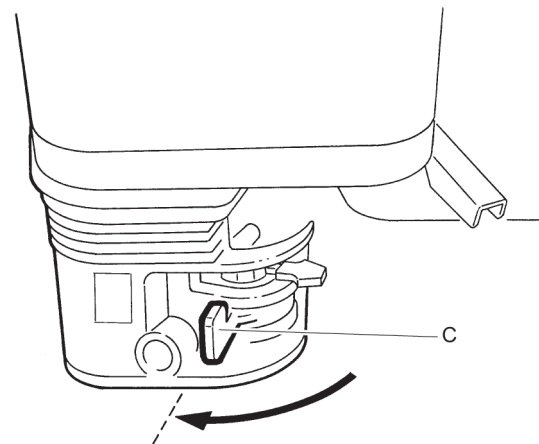

Operating

NOTICE Always operate the machine at full speed, otherwise it prevents the eccentric element from compacting correctly. It can result in machine failure.

Handle positions

NOTICE Always operate the machine forwards, otherwise it opposes the force of the eccentric element which works in a forward direction. Turn the machine around to prevent machine failure.

Raise the handle to the operating position:

1. Loosen the knobs (A).
2. Raise the handle from the folded position.
3. Tighten the knobs when the upper handle (B) is in the correct position.

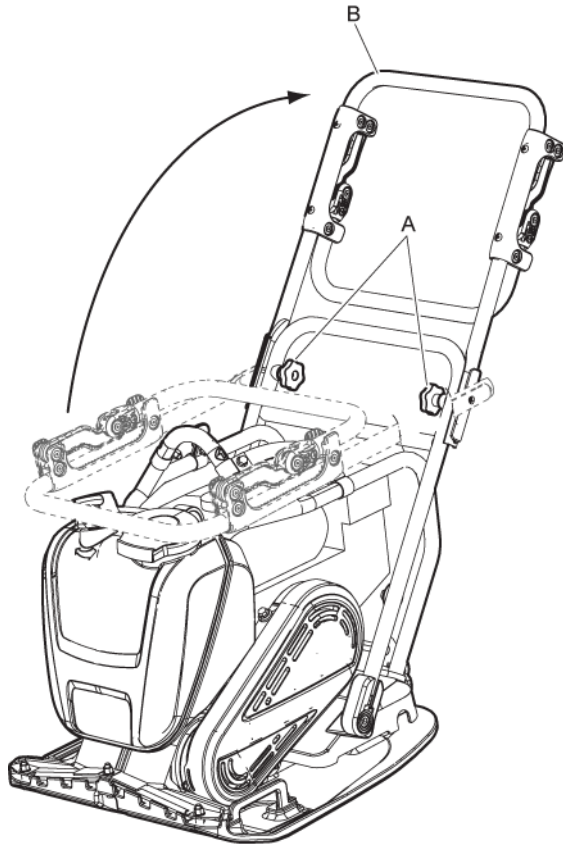

1. Loosen the knobs (A) and lower the handle on top of the machine.
2. Tighten the knobs.

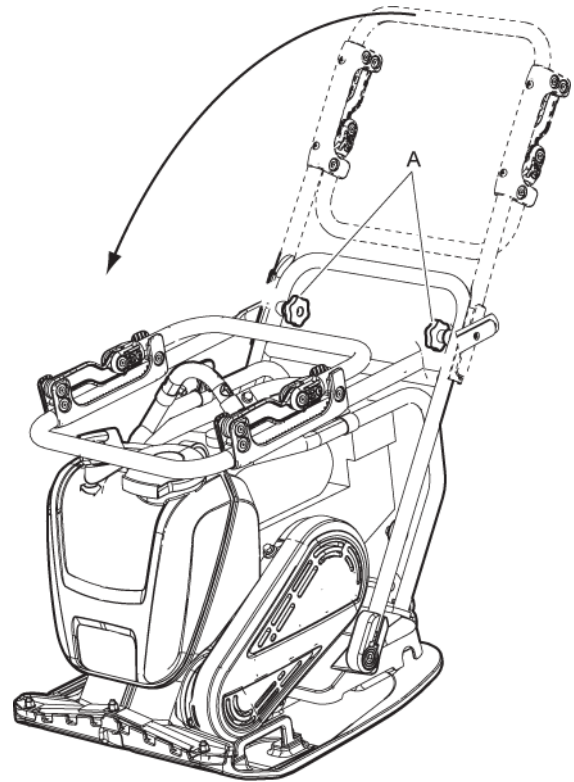

◆ **Raise the handle to turn the machine on the spot:**

Raise the handle to a 90° angle towards the ground, to turn the machine on the spot. This function may be useful in a small narrow place or on uneven ground.

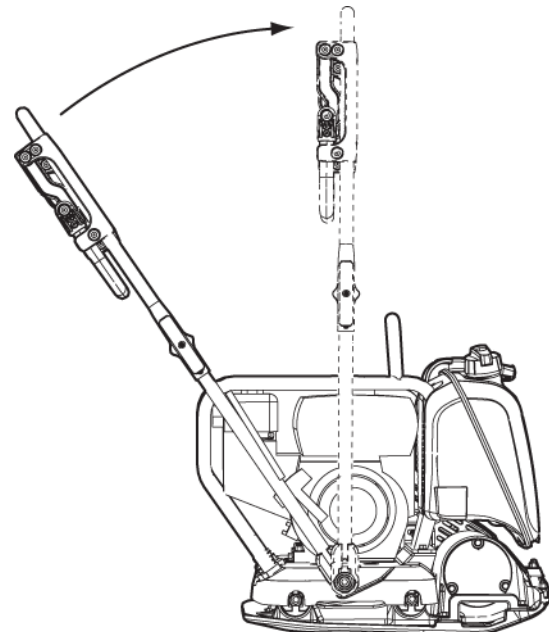

Fold the handle to the transport position:

When taking a break

- ◆ Stop the machine during breaks.
- ◆ During all breaks, put the machine away so that there is no risk for unintentional start.

Maintenance

Regular maintenance is a basic requirement for the continued safe and efficient use of the machine. Follow the maintenance instructions carefully.

- ◆ Before starting maintenance on the machine, clean it in order to avoid exposure to hazardous substances. See “Dust and fume hazard”.
- ◆ Use only authorised parts. Any damage or malfunction caused by the use of unauthorised parts is not covered by warranty or product liability.
- ◆ When cleaning mechanical parts with solvent, comply with appropriate health and safety regulations and ensure there is satisfactory ventilation.
- ◆ For major service of the machine, contact the nearest authorised workshop.
- ◆ After each service, check that the machine's vibration level is normal. If not, contact the nearest authorised workshop.

NOTICE Never aim a water jet directly at the fuel filler cap. This is particularly important when using a high-pressure cleaner.

Every 10 hours of operation (daily)

Maintenance routines:

- ◆ Check and replenish the fuel.
- ◆ Check and replenish lube oil.
- ◆ Check for oil leaks.
- ◆ Clean and refit air filter.
- ◆ Check the tightness of all nuts and bolts.
- ◆ Clean the machine.
- ◆ Check and clean the engine's cooling flanges. See the engine manual for more information.
- ◆ Check that the controls are not damaged and do not jam.

Checking bolted joint

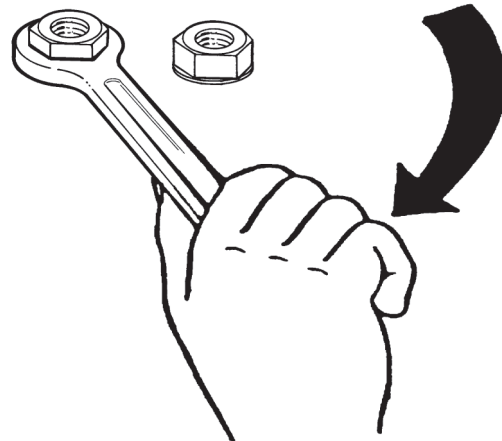

Check and if necessary tighten screws and nuts.

Checking the engine, Honda

- ◆ Check the oil level on the dipstick.

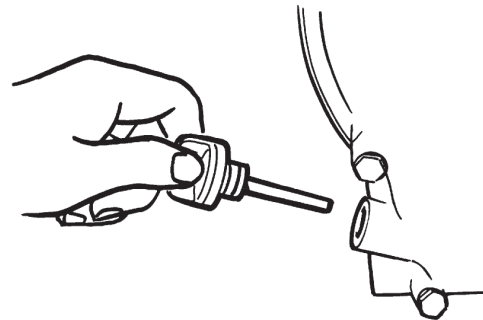

- ◆ Check the fuel level (A).

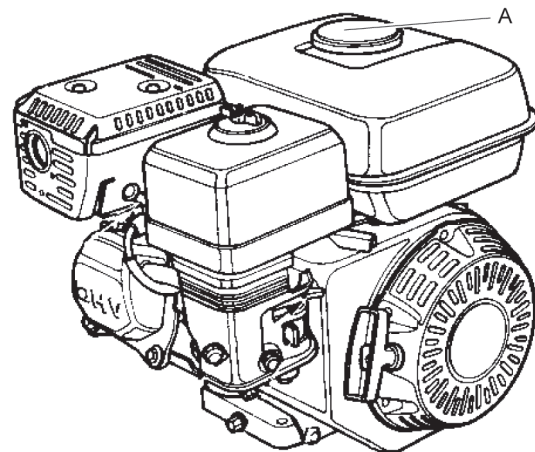

- ◆ Check the engine for oil leaks.

- ◆ Clean and replace the air filter (B) if necessary.

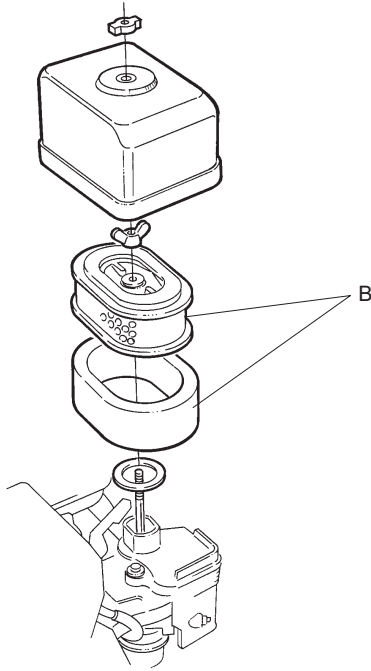

After 20 hours of operation

Maintenance routines:

- ◆ Change engine oil.
- ◆ Clean and refit air filter.
- ◆ Check the engine speed.

Changing the engine oil, Honda

1. Unscrew the drainage plug (A).

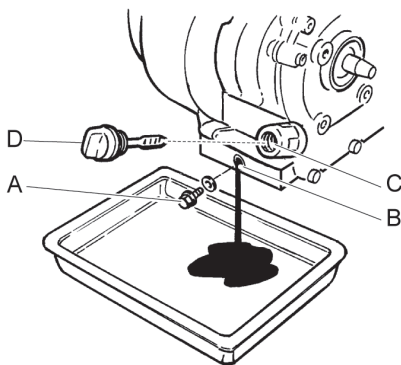

2. Tilt the machine backwards and let the oil drain in a drainage hose.
3. Clean around the hole (B) where the drainage plug (A) was placed.
4. Refit the drainage plug (A).
5. Unscrew the dipstick (D).
6. Fill with oil (C).

7. Refit the dipstick (D).

8. Start the engine and allow the engine to idle a few minutes before increasing to full power.

Every 100 hours of operation (weekly)

Maintenance routines:

- ◆ Check the shock absorbers.
- ◆ Check the engine speed.
- ◆ Check that the V-belt is not damaged.
- ◆ Change engine oil. See engine manual for more information.
- ◆ Check and clean the spark plug. See engine manual for more information.
- ◆ Clean the carburettor's fuel cock. See engine manual for more information.
- ◆ Clean the silencer's spark arrestor. See engine manual for more information.

▲ CAUTION Cover the V-belt

Running a machine without the protective cover over the V-belt may cause trapping or machine damage, which can cause injury.

- ▶ Never run the machine without the protective cover over the V-belt.
- ▶ Stop the engine before removing the protective cover.

Checking the V-belt

The V-belt must be checked and adjusted by authorized service personnel.

1. Remove the protective cover (A).

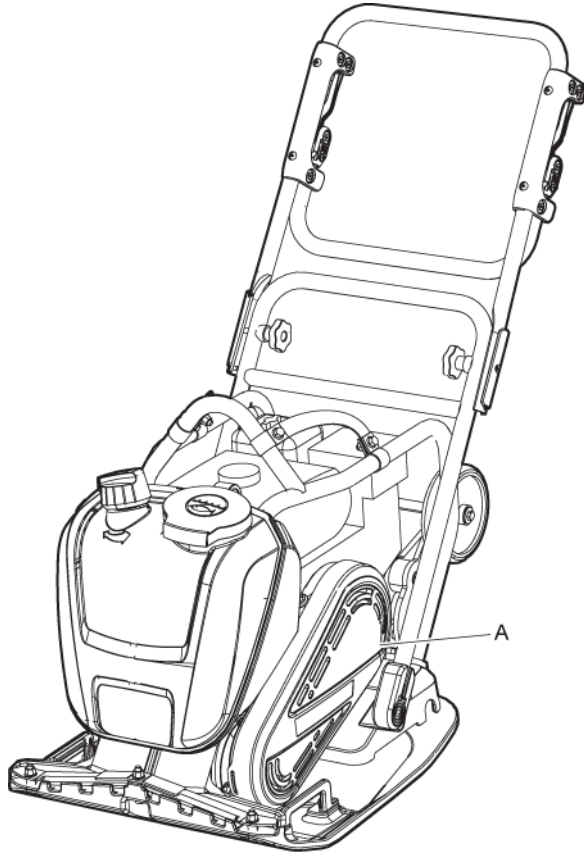

2. Check if the V-belt (B) is damaged, change if necessary.

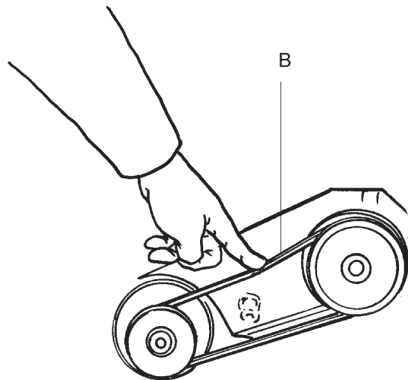

3. If the V-belt tension needs adjusting, loosen the four engine-plate bolts and slide the engine backwards.
4. Check that the V-belt pulleys are in line, tighten the screws and reinstall the protective cover (A).

Checking the shock absorbers

1. Check all the shock absorbers (A) for cracks or if they are exhausted. There are two shock absorbers (A) on each side of the machine.

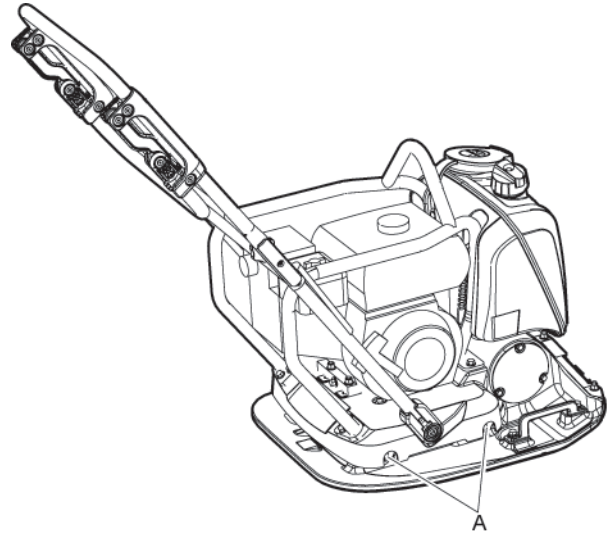

2. Change the shock absorbers (A) if they are damaged.

Checking spark plug, Honda

- ◆ Check, clean and replace the spark plug.

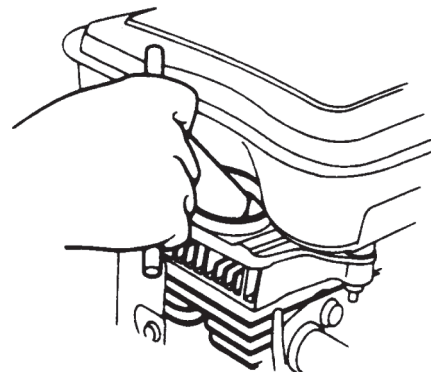

Every 500 hours of operation (yearly)

Maintenance routines:

- ◆ Adjust valve clearance for intake and exhaust valves. See engine manual for more information.
- ◆ Clean and check fuel filter and fuel tank. See engine manual for more information.
- ◆ Replace air filter.
- ◆ Clean the engine's cooling flanges. See engine manual for more information.

- ◆ Change oil in the engine. See engine manual for more information.
- ◆ Clean and adjust the carburettor. See engine manual for more information.

Cleaning the fuel tank

- ◆ Inspect and clean the fuel tank (A).

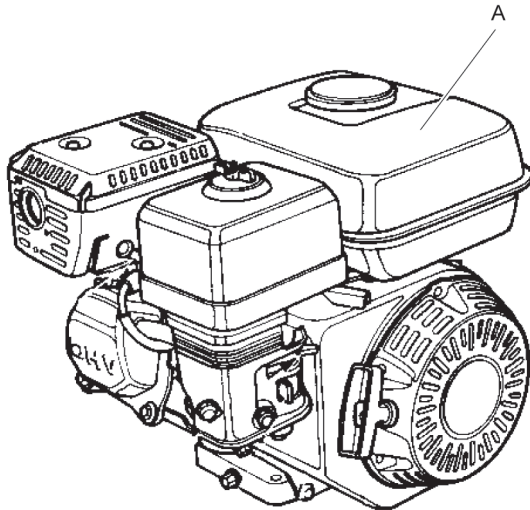

Inspection and adjustment of engine

1. Clean and adjust the carburettor (A).

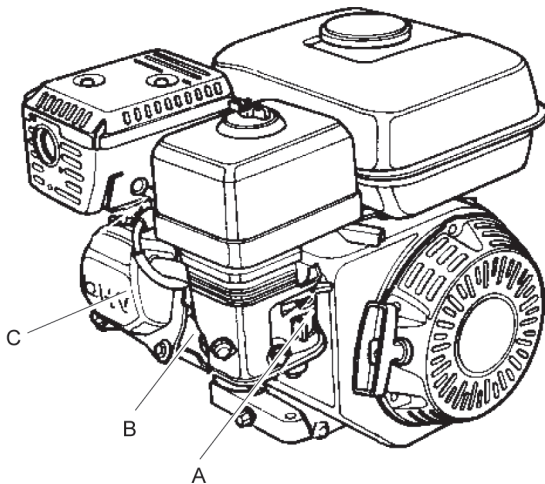

2. Clean engine cooling flanges (B).
3. Adjust the engine's valve (C) clearance.

Disposal

A used machine must be treated and disposed of in such a way that the greatest possible portion of the material can be recycled and any negative influence on the environment is kept as low as possible, and in accordance with local restrictions.

Before a fuel driven machine is deposited it must be emptied and cleaned of all oil and fuel. Remaining oil and fuel must be dealt with in a way that does not adversely affect the environment.

Always send used filters, drained oil and fuel remnants to environmentally correct disposal.

Storage

- ◆ Empty the tank before storing the machine.
- ◆ Clean the machine.
- ◆ Clean the air filter.
- ◆ Carefully pull the start handle until a slight resistance appears.
- ◆ Wipe off any oil and dust that has accumulated on the rubber parts.
- ◆ Cover the machine and store it in a dry, dust-free area.

Technical data

Machine data

LF 75	Honda L / LAT, 420 mm (16.5 in.) width	Honda L / LAT 500 mm (19.7 in.) width
Engine		
Manufacture/Model	Honda GX 160, 4-stroke, manual start.	Honda GX 160, 4-stroke, manual start.
Power, kW (hp)	4.1 (5.6)	4.1 (5.6)
Rated speed, r.p.m.	3,600	3,600
Idling, r.p.m.	1,400	1,400
Compaction data		
Vibration frequency, Hz (r.p.m.)	95 (5700)	95 (5700)
Amplitude, mm (in.)	1.0 (0.39)	0.93 (0.04)
Centrifugal force, kN (lbf)	14.6 (3282)	14.6 (3282)
Performance		
Operating speed, m/min (feet/min)	27 (88.6)	24 (78.7)
Max tilt, ° (%)	20° (30%)	20° (30%)
Fluid volumes		
Fuel tank capacity, litres (qts)	3.6 (3.8)	3.6 (3.8)
Crank case, litres (qts)	0.6 (0.63)	0.6 (0.63)
Fuel consumption, litres/hour (qts/h)	1.21 (1.28)	1.21 (1.28)
Water tank for asphalt, litres (gal)	13 (13.7)	13 (13.7)
Lubricants		
Fuel type	Petrol (gasoline). Use unleaded petrol of standard quality.	Petrol (gasoline). Use unleaded petrol of standard quality.
Engine oil	Shell Rimula R4 L 15W-40	Shell Rimula R4 L 15W-40

Weights

LF 75	Honda L, 420 mm (16.5 in.) width	Honda LAT, asphalt, 420 mm (16.5 in.) width	Honda L, 500 mm (19.7 in.) width	Honda LAT, asphalt, 500 mm (19.7 in.) width
Net weight, kg (lbs)	80.1 (176.6)	86.6 (190.9)	83.5 (184.1)	90.3 (199)
Operating weight EN500, kg (lbs)	81.5 (179.7)	94.5 (208.3)	84.9 (187.2)	96.8 (213.4)

Weights for options

	Honda L / LAT, 420 mm (16.5 in.) width	Honda L / LAT, 500 mm (19.7 in.) width
Protective frame, kg (lbs)	3.9 (8.6)	3.9 (8.6)
Sprinkler system with protective frame, Net weight, kg (lbs)	5.9 (13)	5.9 (13)
Sprinkler system with protective frame, Operating weight EN500, kg (lbs)	12.4 (27.3)	12.4 (27.3)
Front cover with protective frame, kg (lbs)	4.8 (10.6)	4.8 (10.6)
Transport wheel, kg (lbs)	5.4 (11.9)	5.4 (11.9)
Block paving set, kg (lbs)	3.6 (7.9)	4.2 (9.6)
Lifting handle, kg (lbs)	0.6 (1.3)	0.6 (1.3)
Lifting tackle for fork with protective frame, kg (lbs)	4.2(9.3)	4.2(9.3)
Low vibration handle, kg (lbs)	1.2 (2.6)	1.2 (2.6)

Noise and vibration declaration statement

Guaranteed sound power level **L_w** according to EN ISO 3744 in accordance with directive 2000/14/EC.

Sound pressure level **L_p** according to EN ISO 11201, EN 500-4.

Vibration value determined according to EN 500-4. See table "Noise and vibration data" for the values etc.

These declared values were obtained by laboratory type testing in accordance with the stated directive or standards and are suitable for comparison with the declared values of other machines tested in accordance with the same directive or standards. These declared values are not suitable for use in risk assessments and values measured in individual work places may be higher. The actual exposure values and risk of harm experienced by an individual user are unique and depend upon the way the user works, in what material the machine is used, as well as upon the exposure time and the physical condition of the user, and the condition of the machine.

We, Construction Tools EOOD, cannot be held liable for the consequences of using the declared values, instead of values reflecting the actual exposure, in an individual risk assessment in a work place situation over which we have no control.

This machine may cause hand-arm vibration syndrome if its use is not adequately managed. An EU guide to managing hand-arm vibration can be found at <http://www.humanvibration.com/humanvibration/EU/VIBGUIDE.html>

We recommend a programme of health surveillance to detect early symptoms which may relate to vibration exposure, so that management procedures can be modified to help prevent future impairment.

Noise and vibration data

	Noise			Vibration			
	Declared values			Declared values			
	Sound pressure	Sound power		Three axes values			
	EN ISO 11201	2000/14/EC		EN 500-4			
Type	L _p at operator's ear	L _w guaranteed dB(A) rel 1pW	L _w measured dB(A) rel 1pW	m/s ² value		permitted working hours/day	
				Standard handle	Low vibration handle	Standard handle	Low vibration handle
LF 75 Honda	91	104	102	6	1.2	1.4	8

Permitted working hours per day are calculated on action value of 2.5 m/s² as per 2002/44/EC.

Uncertainties, sound value

Uncertainties, sound value		
Type	K _{wA} dB(A)	K _{pA} dB(A)
LF 75 Honda	1.5-2.5	2.5-3.0

Uncertainty factor for gravel bed.

Dimensions

mm (in.)

*Contact area, m²(sq feet).

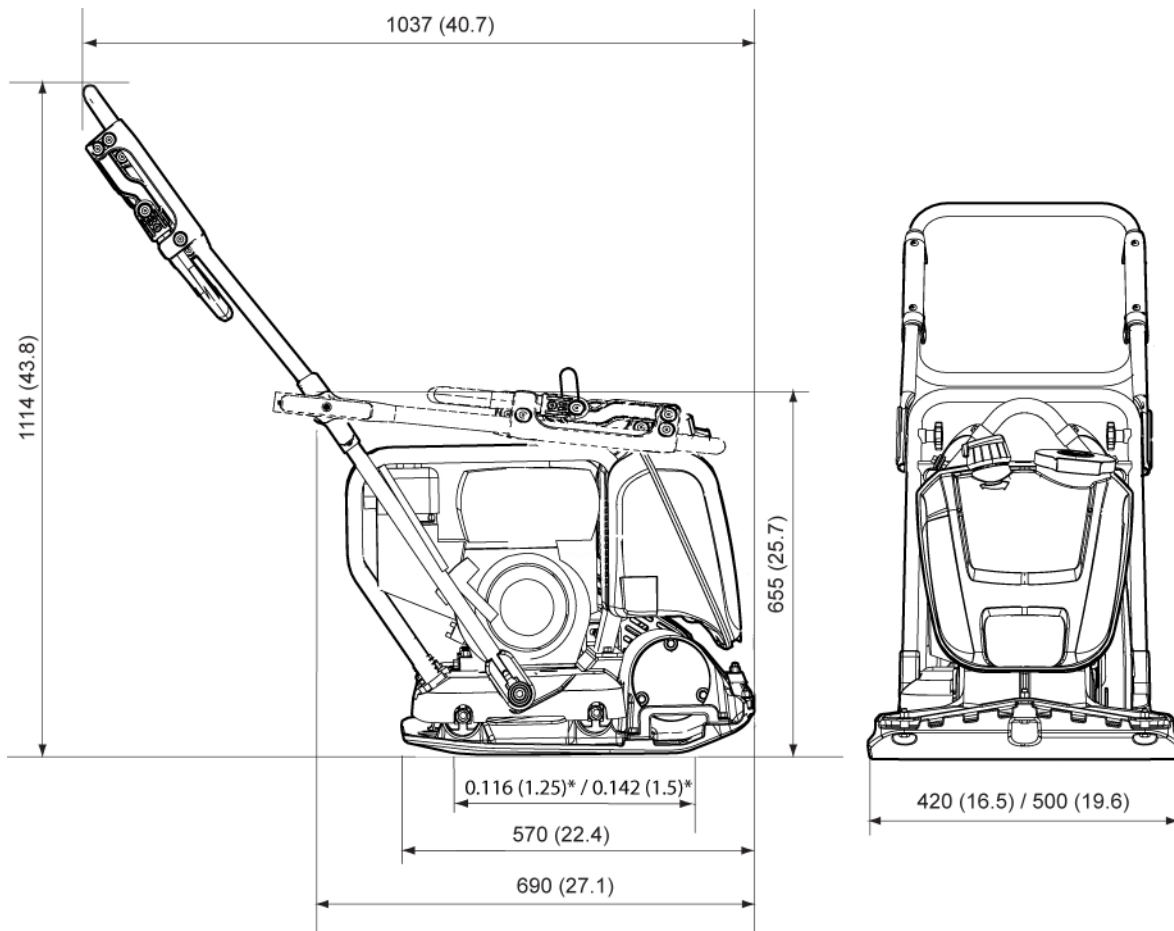

EC Declaration of Conformity

EC Declaration of Conformity (EC Directive 2006/42/EC)

We, Construction Tools EOOD, hereby declare that the machines listed below conform to the provisions of EC Directive 2006/42/EC (Machinery Directive) and 2000/14/EC (Noise Directive), and the harmonised standards mentioned below.

Forward moving vibration plate	Guaranteed sound power level [dB(A)]	Measured sound power level [dB(A)]
LF 75 Honda	104	102

Following harmonised standards were applied:

- ◆ EN500-1+A1
- ◆ EN500-4

Following other standards were applied:

- ◆ 2000/14/EC, appendix VIII
- ◆ 2004/108/EC

Notified body involved for directive:

Mira, NoBo no.0888
 Watling Street
 Nuneaton
 Warwickshire
 CV10 0TU
 UK

Technical Documentation authorised representative:

Emil Alexandrov
 Construction Tools EOOD
 7000 Rousse
 Bulgaria

General Manager:

Nick Evans

Manufacturer:

Construction Tools EOOD
 7000 Rousse
 Bulgaria

Place and date:

Rousse, 2015-05-25

Any unauthorized use or copying of the contents or any part thereof is prohibited.
This applies in particular to trademarks, model denominations, part numbers, and
drawings.

© 2015 Construction Tools EOOD | No. 9800 1121 01c | 2015-05-25

Atlas Copco

www.atlascopco.com