

## LineLazer™ 3400 Airless Line Striper

3A4587E  
EN

***For the application of line striping materials. For professional use only. For outdoor use only. Not approved for use in explosive atmospheres or hazardous locations.***

**Models: 25M224, 25P341 (China Model Only)**  
3300 psi (22.8 MPa, 228 bar) Maximum Operating Pressure



### Important Safety Instructions

Read all warnings and instructions in this manual, related manuals, and on the equipment. Be familiar with the controls and the proper usage of the equipment. Save these instructions.

#### Related Manuals:

Related Manuals:	
311254	Gun
309250	Pump

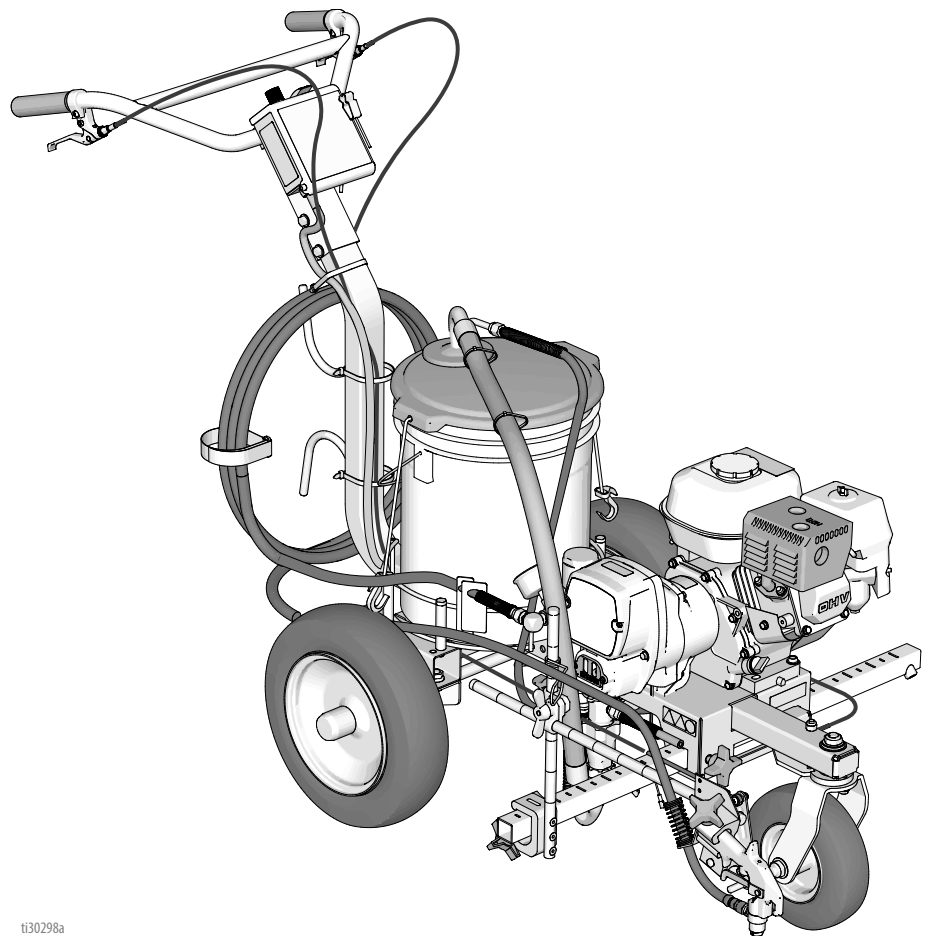











ti30298a

# Contents

<b>Warnings</b> .....	<b>3</b>	<b>Clutch Housing</b> .....	<b>30</b>
<b>Tip Selection</b> .....	<b>6</b>	Removal .....	30
<b>Component Identification</b> .....	<b>7</b>	Installation .....	30
<b>Grounding Procedure (For Flammable Materials Only)</b> .....	<b>8</b>	<b>Engine</b> .....	<b>30</b>
Pails .....	8	Removal .....	30
<b>Pressure Relief Procedure</b> .....	<b>9</b>	Installation .....	30
Front Wheel Alignment: .....	10	<b>Pressure Control Transducer</b> .....	<b>31</b>
<b>Operation</b> .....	<b>11</b>	Removal .....	31
Setup .....	11	Installation .....	31
Startup .....	12	<b>Pressure Control (On/Off Switch)</b> .....	<b>32</b>
Rac Tip and Guard Assembly .....	14	Removal .....	32
<b>Gun Placement</b> .....	<b>15</b>	Installation .....	32
Install Gun .....	15	<b>Pressure Adjust Potentiometer</b> .....	<b>33</b>
Position Gun .....	15	Removal .....	33
<b>Paint Stripe Width</b> .....	<b>17</b>	Installation .....	33
Spray Test Stripe .....	17	<b>Control Board</b> .....	<b>33</b>
Clearing Tip Clogs .....	17	Removal .....	33
<b>Clean-up</b> .....	<b>18</b>	Installation .....	33
<b>Flushing Recommendations</b> .....	<b>21</b>	<b>Parts Drawing</b> .....	<b>34</b>
<b>Troubleshooting</b> .....	<b>22</b>	25M224 .....	34
<b>Displacement Pump</b> .....	<b>24</b>	<b>Parts List - 25M224</b> .....	<b>35</b>
Removal .....	24	<b>Parts Drawing</b> .....	<b>36</b>
Repair .....	24	<b>Parts List - 25M224</b> .....	<b>37</b>
Installation .....	25	<b>Parts Drawing and List - Pinion Housing</b> .....	<b>38</b>
<b>Drive Housing and Connecting Rod</b> .....	<b>26</b>	<b>Gun Arm Parts</b> .....	<b>39</b>
Removal .....	26	<b>Pressure Control/Filter Assembly</b> .....	<b>40</b>
Installation .....	26	<b>Parts List - Pressure Control/Filter Assembly</b> ..	<b>41</b>
<b>Pinion Assembly/Clutch Armature/Clamp</b> .....	<b>27</b>	<b>Pressure Control Wiring Diagram</b> .....	<b>42</b>
Pinion Assembly/Clutch Armature Removal ...	27	<b>Technical Data</b> .....	<b>43</b>
Installation .....	28	California Proposition 65 .....	43
Clamp Removal .....	29	<b>Graco Standard Warranty</b> .....	<b>44</b>
Clamp Installation .....	29		







# Warnings

The following warnings are for the setup, use, grounding, maintenance, and repair of this equipment. The exclamation point symbol alerts you to a general warning and the hazard symbols refer to procedure-specific risks. When these symbols appear in the body of this manual or on warning labels, refer back to these Warnings. Product-specific hazard symbols and warnings not covered in this section may appear throughout the body of this manual where applicable.

 <h2 style="margin: 0;">WARNING</h2>	
    	<p><b>SKIN INJECTION HAZARD</b></p> <p>High-pressure spray is able to inject toxins into the body and cause serious bodily injury. In the event that injection occurs, <b>get immediate surgical treatment.</b></p> <ul style="list-style-type: none"> <li>• Do not aim the gun at, or spray any person or animal.</li> <li>• Keep hands and other body parts away from the discharge. For example, do not try to stop leaks with any part of the body.</li> <li>• Always use the nozzle tip guard. Do not spray without nozzle tip guard in place.</li> <li>• Use Graco nozzle tips.</li> <li>• Use caution when cleaning and changing nozzle tips. In the case where the nozzle tip clogs while spraying, follow the <b>Pressure Relief Procedure</b> for turning off the unit and relieving the pressure before removing the nozzle tip to clean.</li> <li>• Equipment maintains pressure after power is shut off. Do not leave the equipment energized or under pressure while unattended. Follow the <b>Pressure Relief Procedure</b> when the equipment is unattended or not in use, and before servicing, cleaning, or removing parts.</li> <li>• Check hoses and parts for signs of damage. Replace any damaged hoses or parts.</li> <li>• This system is capable of producing 3300 psi. Use Graco replacement parts or accessories that are rated a minimum of 3300 psi.</li> <li>• Always engage the trigger lock when not spraying. Verify the trigger lock is functioning properly.</li> <li>• Verify that all connections are secure before operating the unit.</li> <li>• Know how to stop the unit and bleed pressure quickly. Be thoroughly familiar with the controls.</li> </ul>
   	<p><b>FIRE AND EXPLOSION HAZARD</b></p> <p>Flammable fumes, such as solvent and paint fumes, in <b>work area</b> can ignite or explode. Paint or solvent flowing through the equipment can cause static sparking. To help prevent fire and explosion:</p> <ul style="list-style-type: none"> <li>• Use equipment only in well ventilated area.</li> <li>• Do not fill fuel tank while engine is running or hot; shut off engine and let it cool. Fuel is flammable and can ignite or explode if spilled on hot surface.</li> <li>• Eliminate all ignition sources; such as pilot lights, cigarettes, portable electric lamps, and plastic drop cloths (potential static sparking).</li> <li>• Ground all equipment in the work area. See <b>Grounding</b> instructions.</li> <li>• Never spray or flush solvent at high pressure.</li> <li>• Keep work area free of debris, including solvent, rags and gasoline.</li> <li>• Do not plug or unplug power cords, or turn power or light switches on or off when flammable fumes are present.</li> <li>• Use only grounded hoses.</li> <li>• Hold gun firmly to side of grounded pail when triggering into pail. Do not use pail liners unless they are anti-static or conductive.</li> <li>• <b>Stop operation immediately</b> if static sparking occurs or you feel a shock. Do not use equipment until you identify and correct the problem.</li> <li>• Keep a working fire extinguisher in the work area.</li> </ul>



# WARNING

 	<p><b>EQUIPMENT MISUSE HAZARD</b>  <b>Misuse can cause death or serious injury.</b></p> <ul style="list-style-type: none"> <li>• Do not operate the unit when fatigued or under the influence of drugs or alcohol.</li> <li>• Do not exceed the maximum working pressure or temperature rating of the lowest rated system component. See <b>Technical Data</b> in all equipment manuals.</li> <li>• Use fluids and solvents that are compatible with equipment wetted parts. See <b>Technical Data</b> in all equipment manuals. Read fluid and solvent manufacturer's warnings. For complete information about your material, request Safety Data Sheet (SDS) from distributor or retailer.</li> <li>• Do not leave the work area while equipment is energized or under pressure.</li> <li>• Turn off all equipment and follow the <b>Pressure Relief Procedure</b> when equipment is not in use.</li> <li>• Check equipment daily. Repair or replace worn or damaged parts immediately with genuine manufacturer's replacement parts only.</li> <li>• Do not alter or modify equipment. Alterations or modifications may void agency approvals and create safety hazards.</li> <li>• Make sure all equipment is rated and approved for the environment in which you are using it.</li> <li>• Use equipment only for its intended purpose. Call your distributor for information.</li> <li>• Route hoses and cables away from traffic areas, sharp edges, moving parts, and hot surfaces.</li> <li>• Do not kink or over bend hoses or use hoses to pull equipment.</li> <li>• Keep children and animals away from work area.</li> <li>• Comply with all applicable safety regulations.</li> </ul>
	<p><b>PRESSURIZED ALUMINUM PARTS HAZARD</b></p> <p>Use of fluids that are incompatible with aluminum in pressurized equipment can cause serious chemical reaction and equipment rupture. Failure to follow this warning can result in death, serious injury, or property damage.</p> <ul style="list-style-type: none"> <li>• Do not use 1,1,1-trichloroethane, methylene chloride, other halogenated hydrocarbon solvents or fluids containing such solvents.</li> <li>• Do not use chlorine bleach.</li> <li>• Many other fluids may contain chemicals that can react with aluminum. Contact your material supplier for compatibility.</li> </ul>
 	<p><b>MOVING PARTS HAZARD</b></p> <p>Moving parts can pinch, cut, or amputate fingers and other body parts.</p> <ul style="list-style-type: none"> <li>• Keep clear of moving parts.</li> <li>• Do not operate equipment with protective guards or covers removed.</li> <li>• Pressurized equipment can start without warning. Before checking, moving, or servicing equipment, follow the <b>Pressure Relief Procedure</b> and disconnect all power sources.</li> </ul>
	<p><b>CARBON MONOXIDE HAZARD</b></p> <p>Exhaust contains poisonous carbon monoxide, which is colorless and odorless. Breathing carbon monoxide can cause death.</p> <ul style="list-style-type: none"> <li>• Do not operate in an enclosed area.</li> </ul>
	<p><b>TOXIC FLUID OR FUMES HAZARD</b></p> <p>Toxic fluids or fumes can cause serious injury or death if splashed in the eyes or on skin, inhaled, or swallowed.</p> <ul style="list-style-type: none"> <li>• Read SDS to know the specific hazards of the fluids you are using.</li> <li>• Store hazardous fluid in approved containers, and dispose of it according to applicable guidelines.</li> </ul>

**WARNING****BURN HAZARD**

Equipment surfaces and fluid that's heated can become very hot during operation. To avoid severe burns:



- Do not touch hot fluid or equipment.

**PERSONAL PROTECTIVE EQUIPMENT**

Wear appropriate protective equipment when in the work area to help prevent serious injury, including eye injury, hearing loss, inhalation of toxic fumes, and burns. This protective equipment includes but is not limited to:

- Protective eyewear, and hearing protection.
- Respirators, protective clothing, and gloves as recommended by the fluid and solvent manufacturer.

# Tip Selection

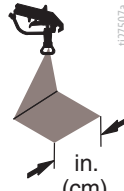
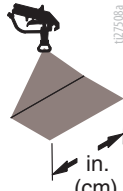
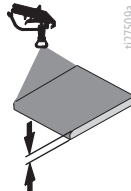
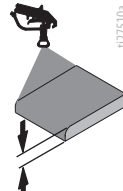
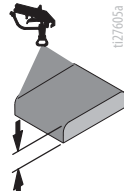
							
	in. (cm)	in. (cm)	in. (cm)	in. (cm)			
LL5213*	2 (5)				✓		
LL5215*	2 (5)					✓	
LL5217		4 (10)				✓	
LL5219		4 (10)					✓
LL5315		4 (10)			✓		
LL5317		4 (10)			✓		
LL5319		4 (10)				✓	
LL5321		4 (10)				✓	
LL5323		4 (10)				✓	
LL5325		4 (10)					✓
LL5327		4 (10)					✓
LL5329		4 (10)					✓
LL5331		4 (10)					✓
LL5333		4 (10)					✓
LL5335		4 (10)					✓
LL5355		4 (10)					✓
LL5417			6 (15)		✓		
LL5419			6 (15)		✓		
LL5421			6 (15)		✓		
LL5423			6 (15)			✓	
LL5425			6 (15)			✓	
LL5427			6 (15)			✓	
LL5429			6 (15)			✓	
LL5431			6 (15)				✓
LL5435			6 (15)				✓
LL5621				12 (30)	✓		
LL5623				12 (30)	✓		
LL5625				12 (30)	✓		
LL5627				12 (30)	✓		
LL5629				12 (30)	✓		
LL5631				12 (30)		✓	
LL5635				12 (30)		✓	
LL5639				12 (30)			✓

\*Use 100 mesh filter to reduce tip clogs.

# Component Identification

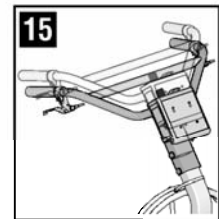
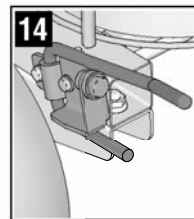
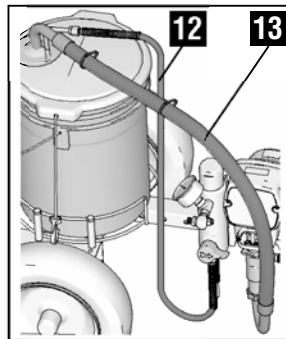
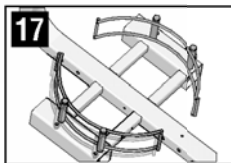
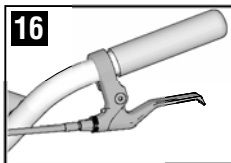
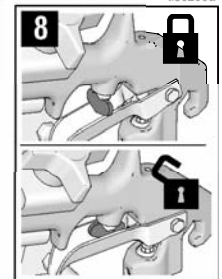
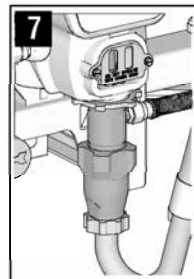
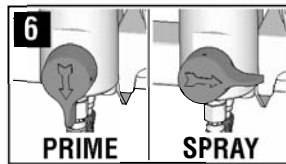
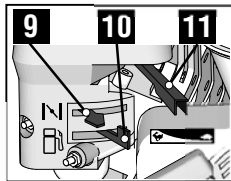
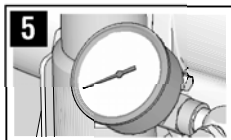
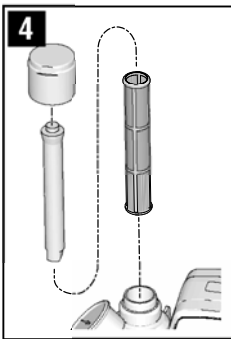
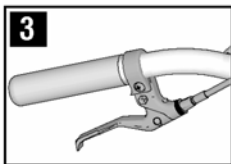
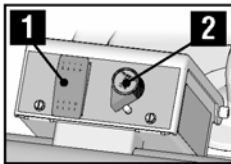
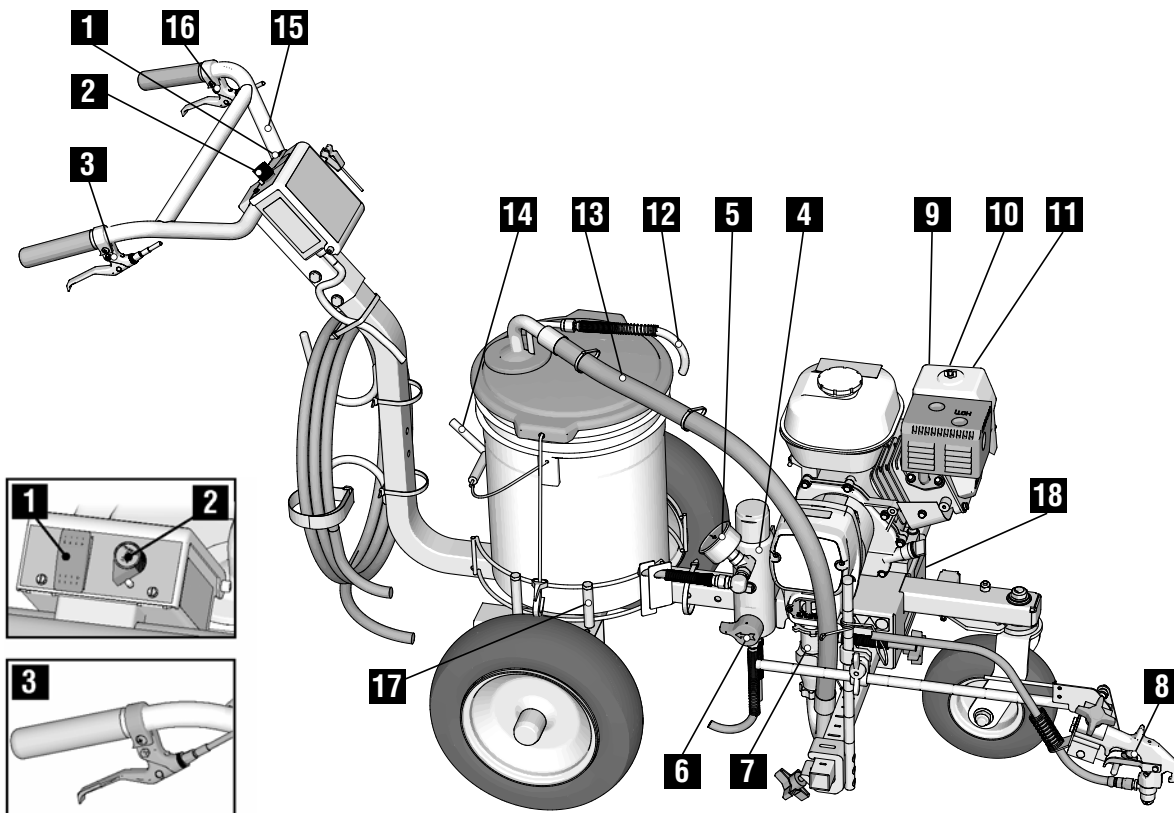

i130299a

1	Pump ON/OFF Switch
2	Pressure Control
3	Spray Gun Trigger
4	Filter
5	Pressure Gauge
6	Prime Valve
7	Pump
8	Trigger Lock
9	Choke

10	Engine ON/OFF Switch
11	Throttle
12	Drain Hose
13	Suction Tube
14	Parking Brake
15	Adjustable Handle
16	Front Wheel Unlock/Lock
17	Adjustable Pail Holder
18	Serial ID

# Grounding Procedure (For Flammable Materials Only)



This equipment must be grounded to reduce the risk of static sparking. Static sparking can cause fumes to ignite or explode. Grounding provides an escape wire for the electric current.

1. Position striper so that the tires are not on pavement.
2. Striper is shipped with a grounding clamp. Grounding clamp must attach to grounded object. (e.g. metal sign post).

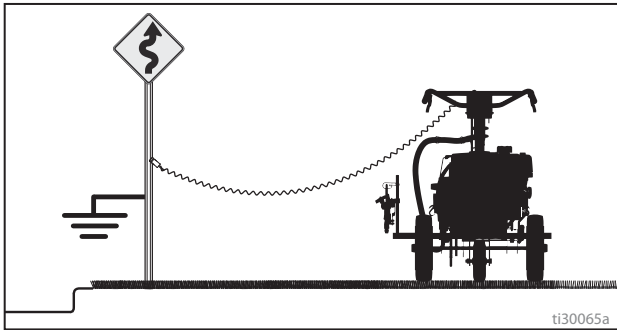

## Pails

**Solvent and oil-based fluids:** follow local code. Use only conductive metal pails, placed on a grounded surface such as concrete.

Do not place pail on a non-conductive surface such as paper or cardboard which interrupts grounding continuity.

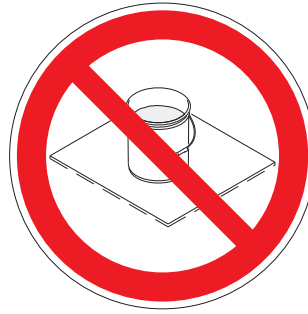

**Always ground a metal pail:** connect a ground wire to the pail. Clamp one end to the pail and the other end to a true earth ground such as a water pipe.

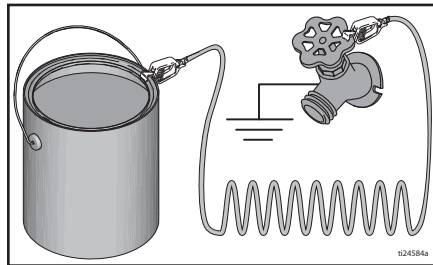

**To maintain ground continuity when sprayer is flushed or pressure is relieved:** hold metal part of spray gun firmly to the side of a grounded metal pail then trigger the gun.

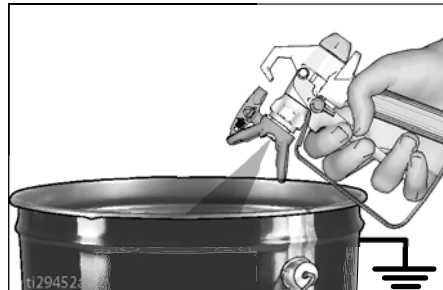



# Pressure Relief Procedure



Follow the **Pressure Relief Procedure** whenever you see this symbol.

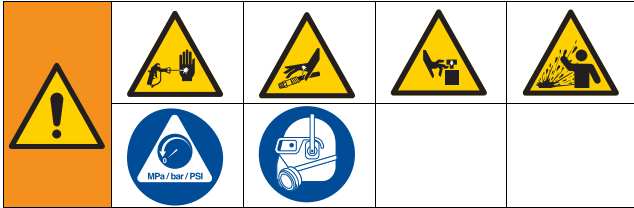

This equipment stays pressurized until pressure is manually relieved. To help prevent serious injury from pressurized fluid, such as skin injection, splashed fluid and moving parts, follow the **Pressure Relief Procedure** whenever sprayer is stopped and before sprayer is cleaned or checked, and before equipment is serviced.

1. Perform **Grounding Procedure** if using flammable materials.
2. Set pump switch **OFF**. Turn engine **OFF**.

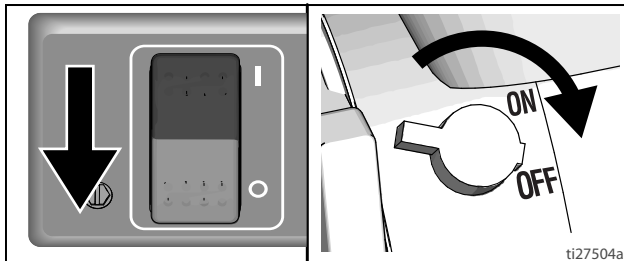

3. Turn pressure to lowest setting. Trigger gun to relieve pressure.

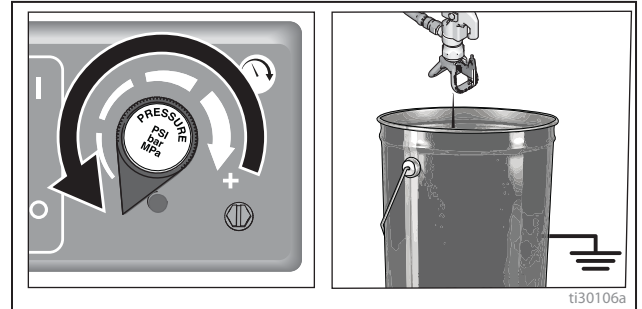

4. Engage the trigger lock. Turn prime valve down.

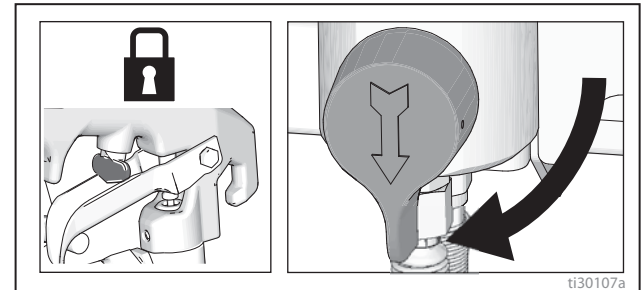

5. If you suspect the spray tip or hose is clogged or that pressure has not been fully relieved:
  - a. **VERY SLOWLY** loosen tip guard retaining nut or hose end coupling to relieve pressure gradually.
  - b. Loosen nut or coupling completely.
  - c. Clear hose or tip obstruction.

**DAILY:** Check engine oil level and fill as necessary.

**DAILY:** Check hose for wear and damage.

**DAILY:** Check gun safety for proper operation.

**DAILY:** Check pressure drain valve for proper operation.

**DAILY:** Check and fill the gas tank.

**DAILY:** Check level of TSL in displacement pump packing nut. Fill nut, if necessary. Keep TSL in nut to help prevent fluid buildup on piston rod and premature wear of packings and pump corrosion.**AFTER THE FIRST 20 HOURS OF OPERATION:**

Drain engine oil and refill with clean oil. Reference Honda Engines Owner's Manual for correct oil viscosity.

**WEEKLY:** Remove engine air filter cover and clean element. Replace element, if necessary. If operating in an unusually dusty environment: check filter daily and replace, if necessary.

Replacement elements can be purchased from your local HONDA dealer.

**AFTER EACH 100 HOURS OF OPERATION:**

Change engine oil. Reference Honda Engines Owner's Manual for correct oil viscosity.

**SPARK PLUG:** Use only BPR6ES (NGK) or W20EPR-U (NIPPONDENSO) plug. Gap plug to 0.028 to 0.031 in. (0.7 to 0.8 mm). Use spark plug wrench when installing and removing plug.

## Front Wheel Alignment:

Align front wheel as follows:

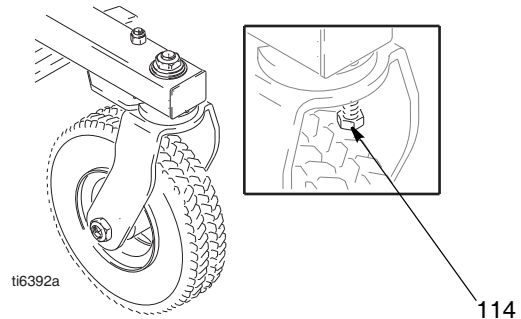

1. Loosen cap screw (114).



2. Position front wheel left or right, as necessary, to straighten alignment.
3. Tighten cap screw (114). Push striper and let striper roll with hands off of striper. Note: If striper rolls straight or veers right or left. Repeat steps 1 and 2 until striper rolls straight.

# Operation

## Setup

				
<p>The equipment must be grounded to reduce the risk of static sparking. Static sparking can cause fumes to ignite or explode. Grounding provides an escape wire for the electric current.</p>				

1. Ground striper with grounding clamp.

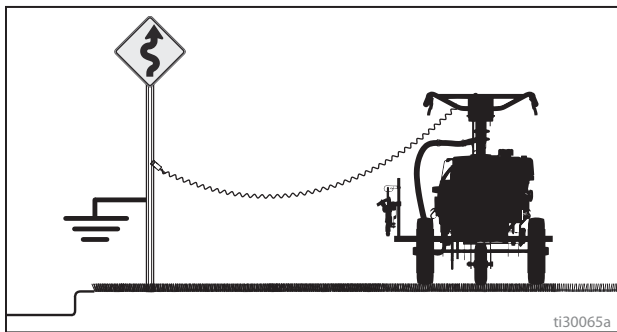

2. Fill throat packing nut with TSL.

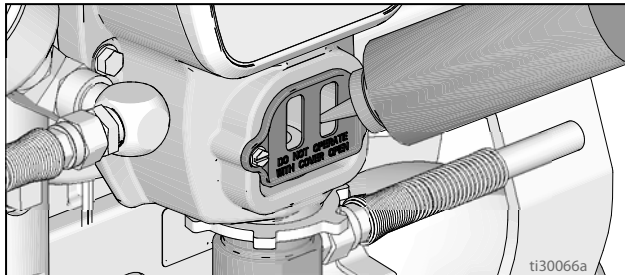

3. Check engine oil level. See Honda engine manual.

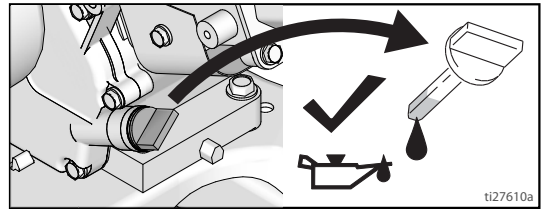

4. Fill fuel tank. See Honda engine manual. Check that tires are inflated to recommended pressure.

# Startup

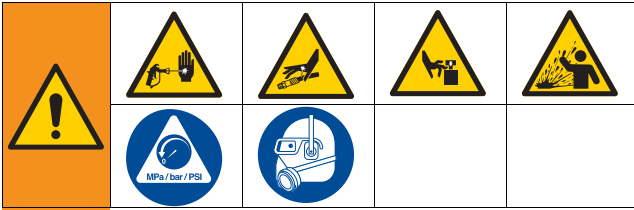

1. Perform Pressure Relief Procedure. See **Grounding Procedure (For Flammable Materials Only)**, page 8.
2. Place siphon tube set in grounded metal pail partially filled with flushing fluid. Attach ground wire to pail and to true earth ground. Use water to flush water-base paint and mineral spirits to flush oil-base paint and storage oil.

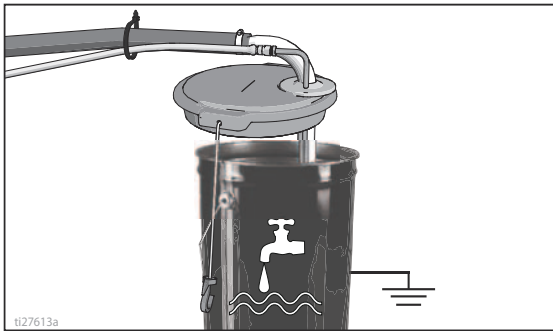

3. Turn prime valve down.

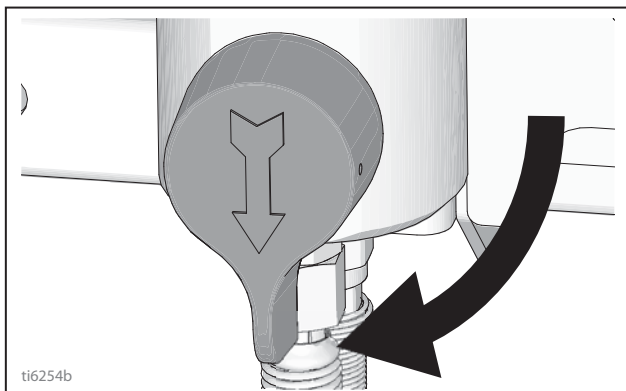

4. Turn pressure control counterclockwise to lowest pressure.

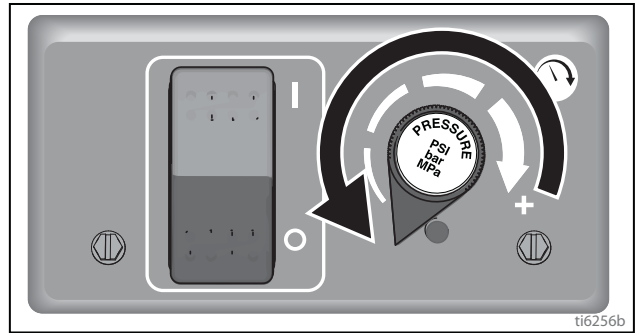

5. Set pump switch to OFF.

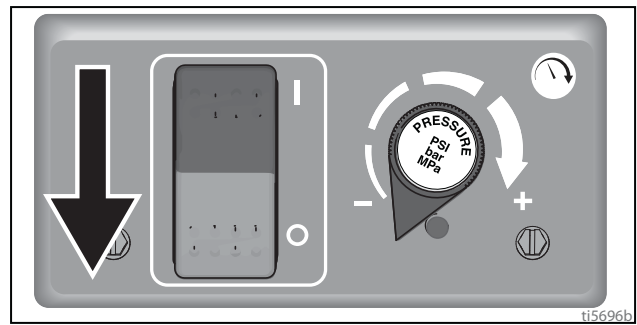

6. Start Engine.
  - a. Move fuel valve to open.

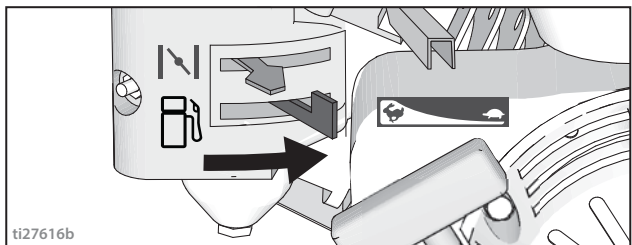

- b. Move choke to closed.

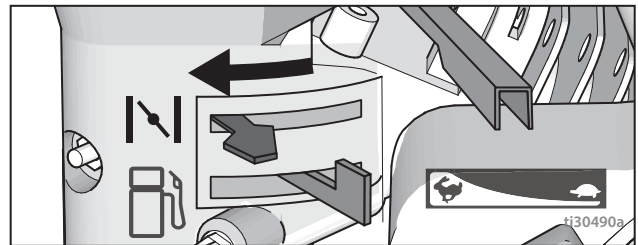

c. Set throttle to fast.

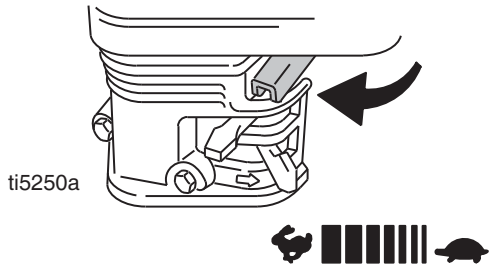

d. Set engine switch to ON.

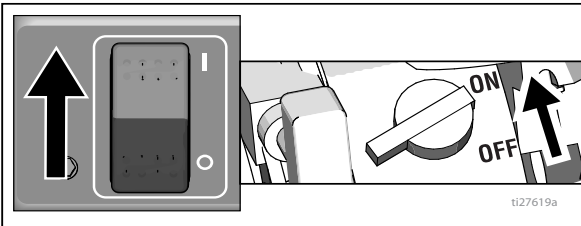

e. Pull starter cord.

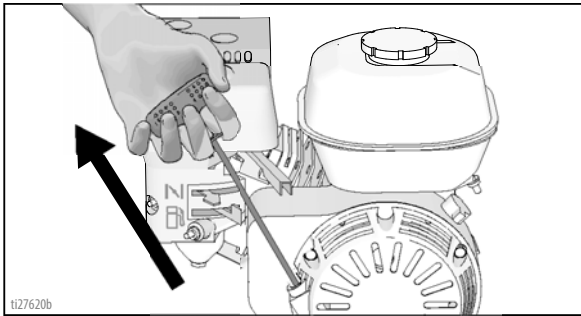

f. After engine starts, move choke to open.

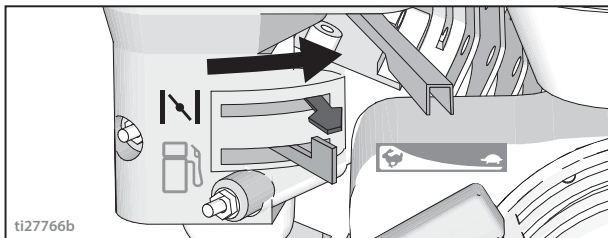

g. Set throttle to slow.

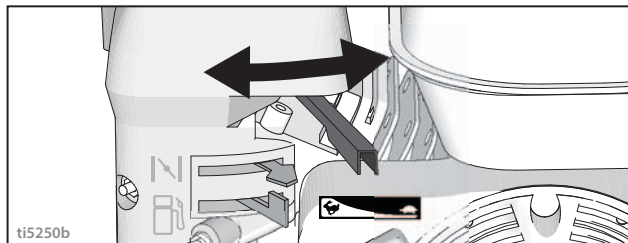

**NOTICE**

Do not run pump without fluid flow. Damage to packings can occur.

7. Set pump switch to ON. Increase pressure enough to start pump. Allow fluid to circulate for 15 seconds.

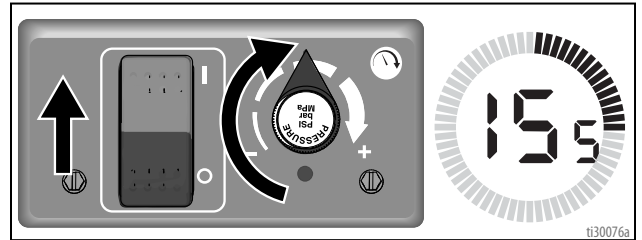

8. Turn pressure down, close prime valve. Disengage gun trigger lock.

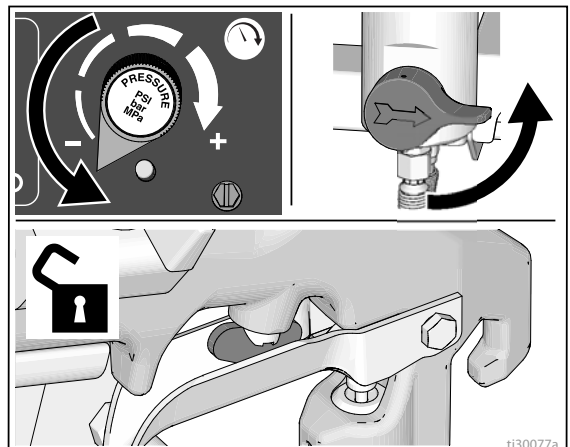

9. Hold gun against grounded metal flushing pail. Trigger gun and increase fluid pressure slowly until pump runs smoothly.

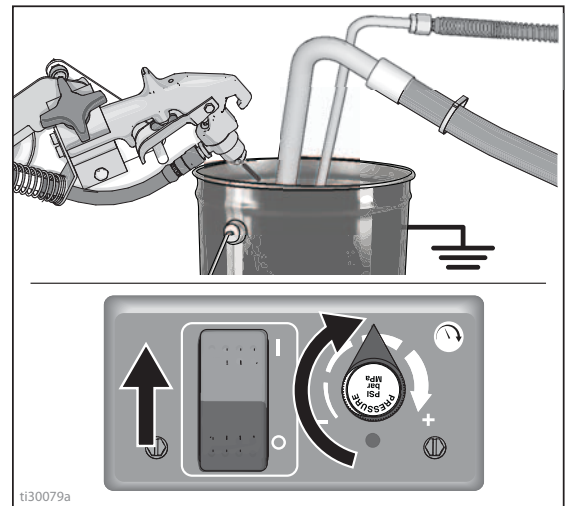



High-pressure spray is able to inject toxins into the body and cause serious bodily injury. Do not stop leaks with hand or rag.

10. Inspect fittings for leaks. Do not stop leaks with your hand or a rag! If leaks occur, turn striper OFF immediately. Perform **Grounding Procedure (For Flammable Materials Only)**, page 8. Tighten leaky fittings. Repeat **Startup**, steps 1 - 7. If no leaks, continue to trigger gun until system is thoroughly flushed. Proceed to step 8.

11. Place siphon tube in paint pail.

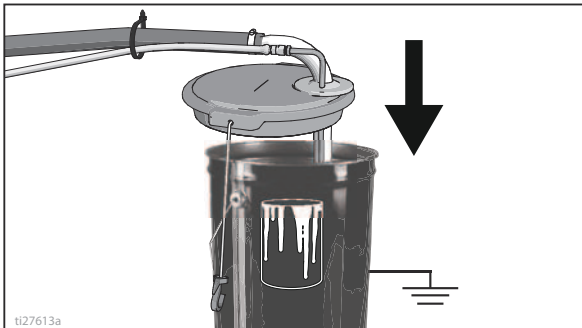

12. Trigger gun again into flushing fluid pail until paint appears. Assemble Rac Tip and Rac Guard.

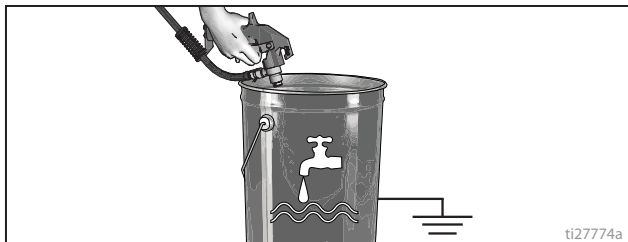

## Rac Tip and Guard Assembly



To avoid serious injury from skin injection do not put your hand in front of the spray tip when installing or removing the spray tip and tip guard.

To prevent spray tip leaks, make certain spray tip and tip guard are installed properly.

1. Perform **Pressure Relief Procedure**, page 8.
2. Engage trigger lock. Insert seat and Rac Tip Seal. Insert Rac Tip.

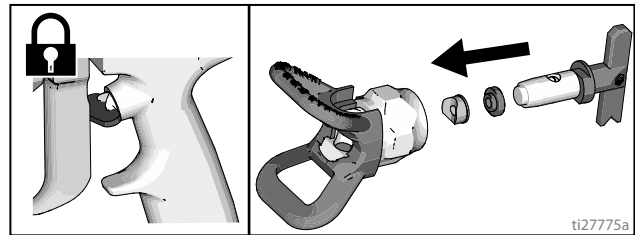

3. Screw assembly onto gun. Hand tighten.

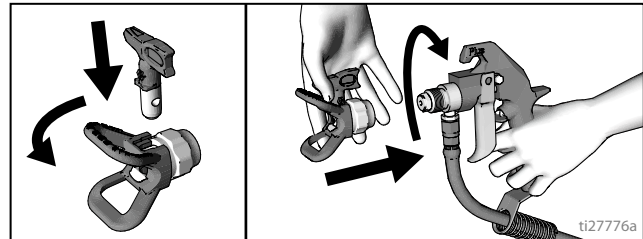

# Gun Placement

## Install Gun

1. Insert gun into gun holder with hose guard pressed against the holder assembly bracket. Tighten gun into clamp.

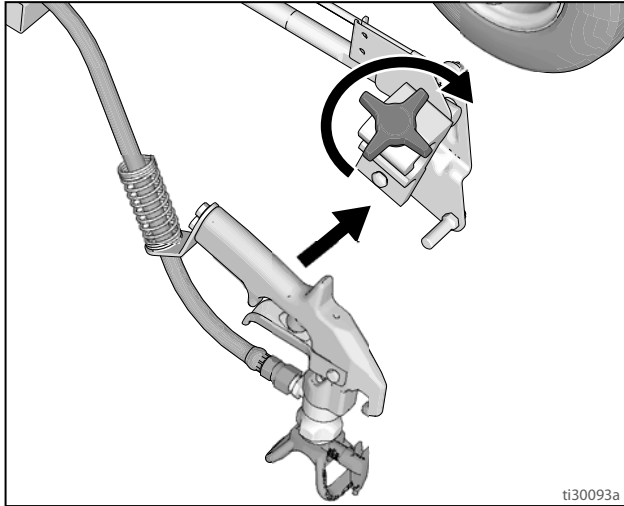

## Position Gun

2. Position gun up/down and forward/reverse.

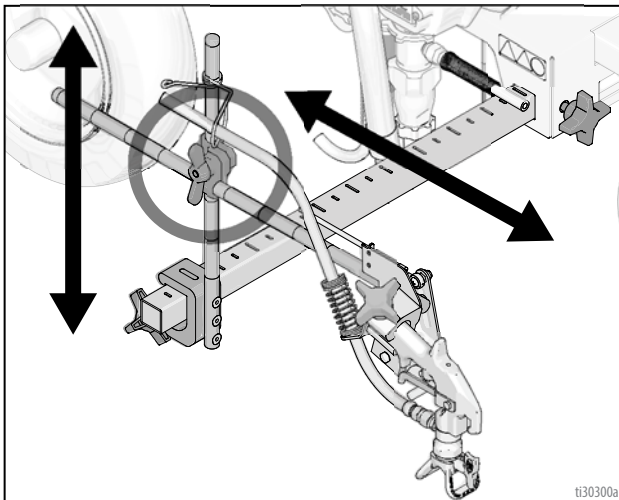

3. Position gun left/right.

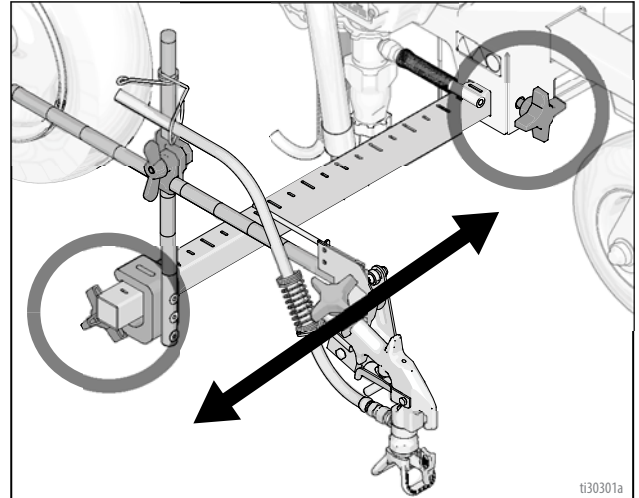

- a. **Right-side gun position:** Place gun and related hardware on right-hand side.

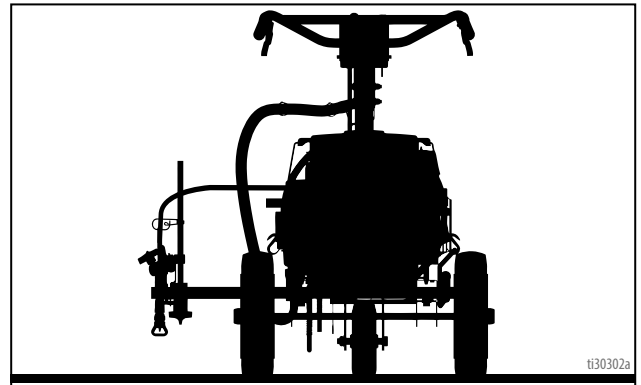

## Gun Placement

- b. **Left-side gun position:** Place gun and related hardware on left-hand side.

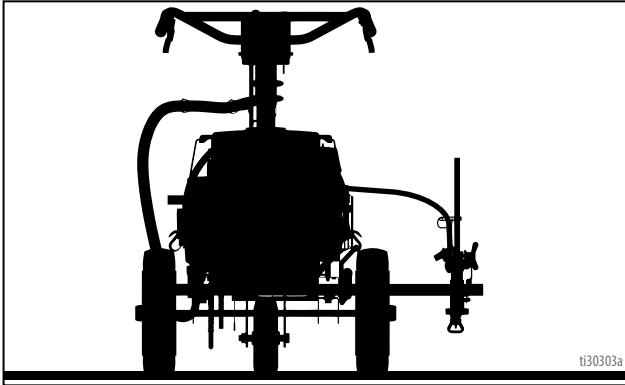

4. For **Curb Position**, place gun at 45° angle.

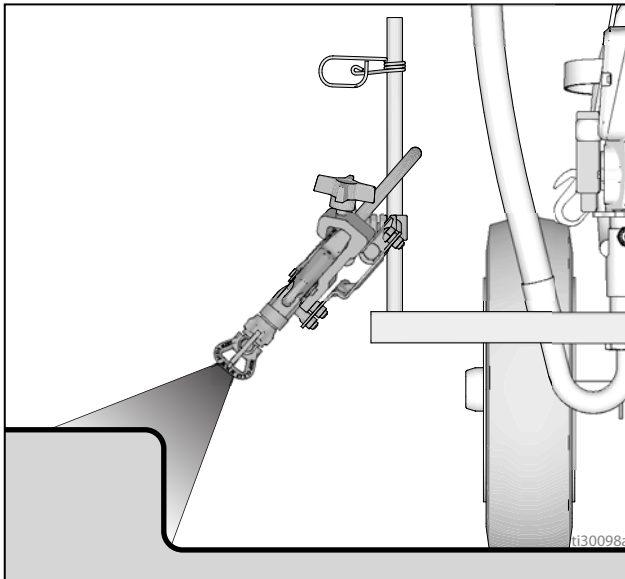

5. For **Gun Arc Spray Position**, place gun at rear of striper. Rear position improves arc quality.

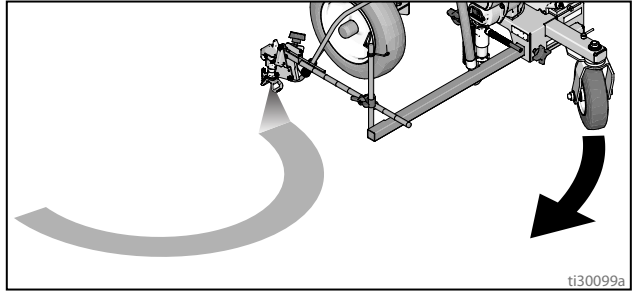

**NOTE:** Verify that the gun can still be triggered **and** that the trigger lock can still be engaged after installation. Make adjustments if necessary.



# Paint Stripe Width

1. Adjust gun up or down to change paint stripe width. If desired width can't be attained, change tip.

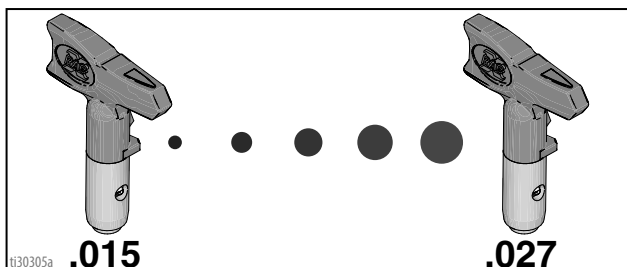
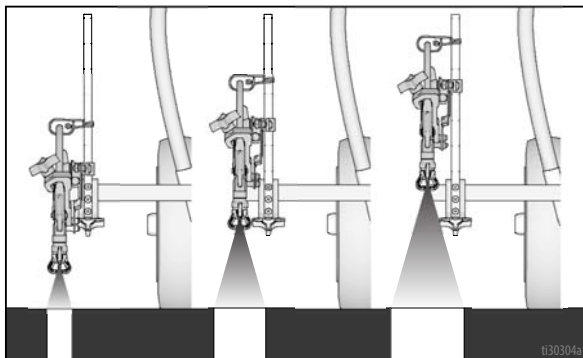

2. Trigger gun and spray test pattern. Slowly adjust pressure to eliminate heavy edges. Use smaller tip size if pressure adjustment can not eliminate heavy edges.

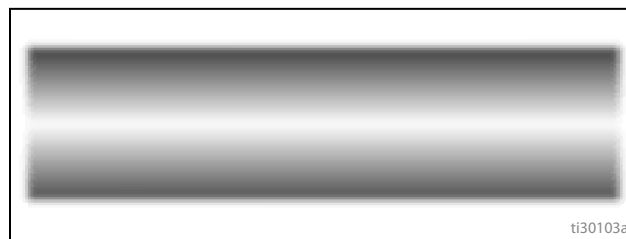

## Clearing Tip Clogs



1. Release trigger. Engage gun trigger lock. Rotate Rac Tip. Disengage gun trigger lock and trigger gun to clear the clog.

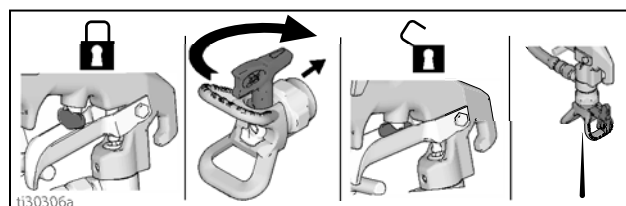

2. Engage gun trigger lock, return Rac Tip to original position, disengage gun trigger lock and continue spraying.

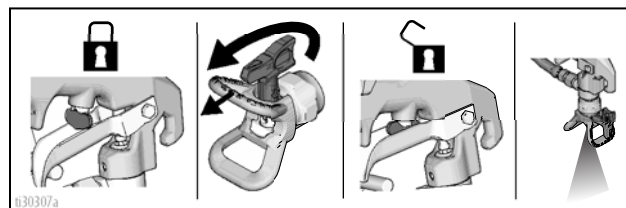

## Spray Test Stripe

1. Disengage trigger lock.

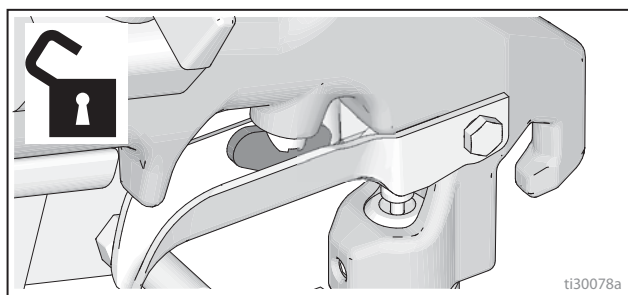

# Clean-up

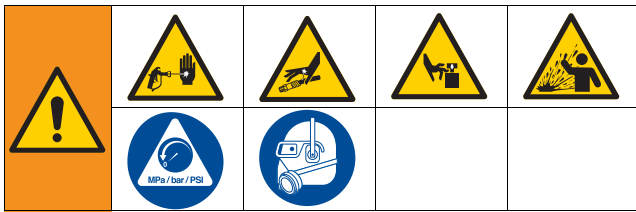

1. Perform Pressure Relief Procedure. See **Pressure Relief Procedure**, page 8.
2. Remove Rac Guard and Rac Tip.

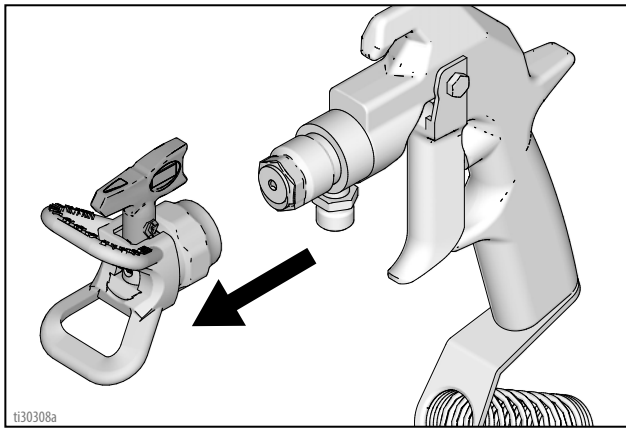

3. Unscrew cap, remove filter. Assemble without filter. Clean filter.

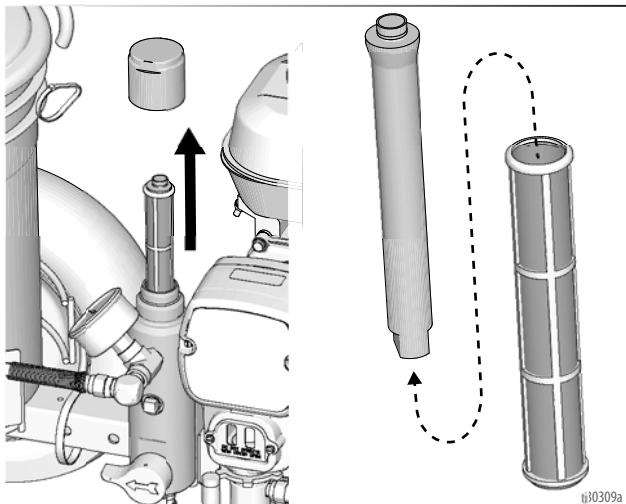

4. Clean gun filter, Rac Guard and Rac Tip in flushing fluid. See **Flushing Recommendations**, page 21.

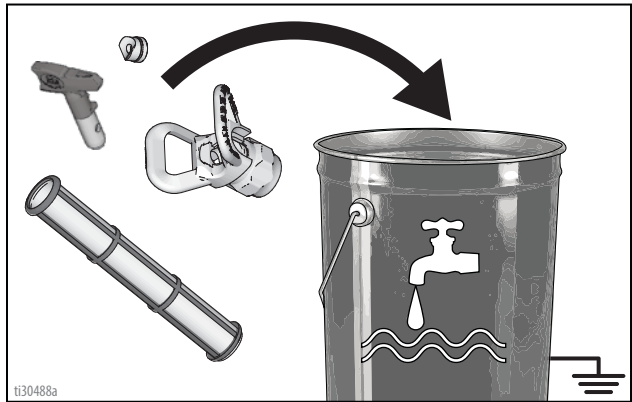

5. Remove siphon tube set from paint and place in flushing fluid. Use water or pump conditioner for water-base paint and mineral spirits for oil-base paint.

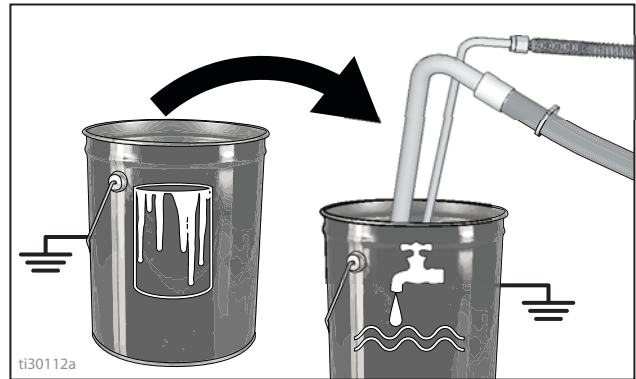

6. Turn engine **ON** and start engine. Set pump switch **ON**.

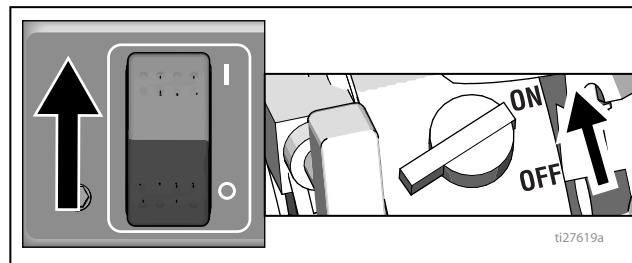

7. Close prime valve.

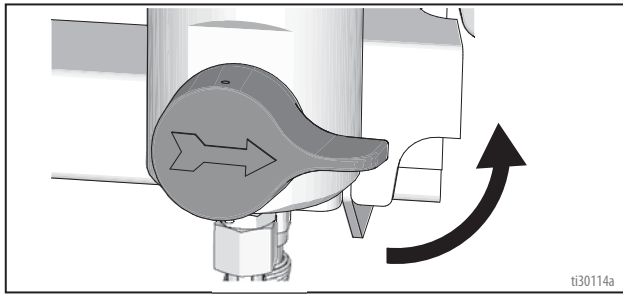

8. Hold gun against paint pail. Disengage gun trigger lock.

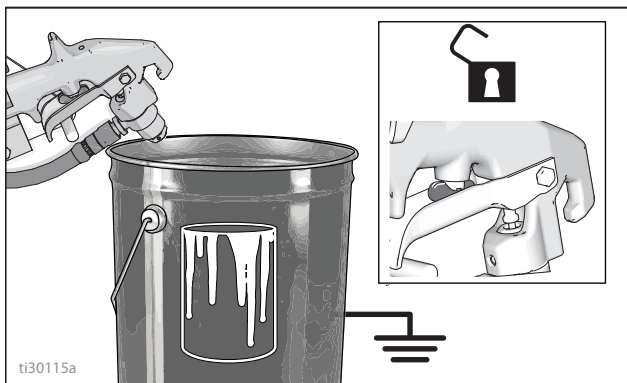

9. Gradually turn pressure control up until motor begins to drive pump. Trigger gun until flushing fluid appears.

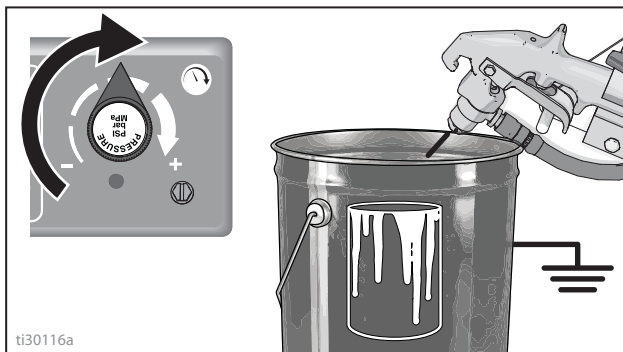

10. Move gun to flushing pail, hold gun against pail, trigger gun to thoroughly flush system. Release trigger and engage trigger lock.

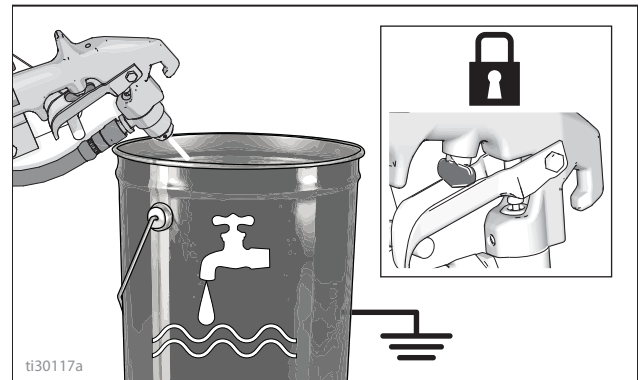

11. Open prime valve and allow flushing fluid to circulate for 20 seconds to clean drain tube.

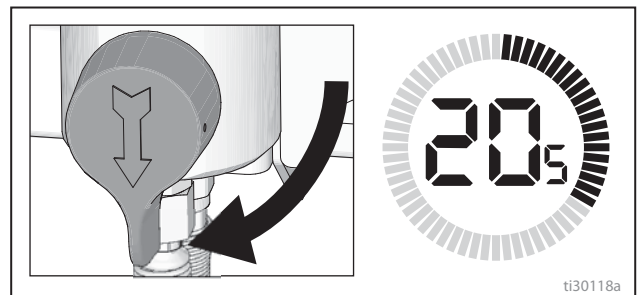

**NOTICE**

Do not run pump without fluid flow. Damage to packings can occur.

- 12. Raise siphon tube above flushing fluid and run striper for 15 to 30 seconds to drain fluid.

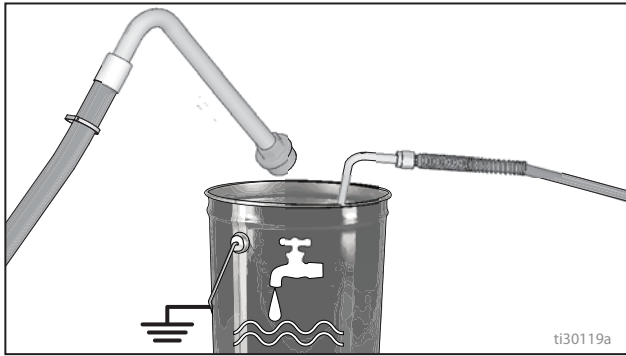

- 13. Turn pump switch **OFF**. Turn engine **OFF**.

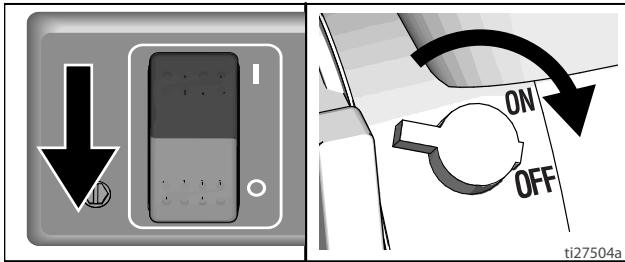

**NOTICE**

If flushing with water, do not leave water in sprayer for extended periods. Flush again with Pump Armor and leave protective coating in the sprayer to prevent freezing or corrosion and to increase sprayer life.

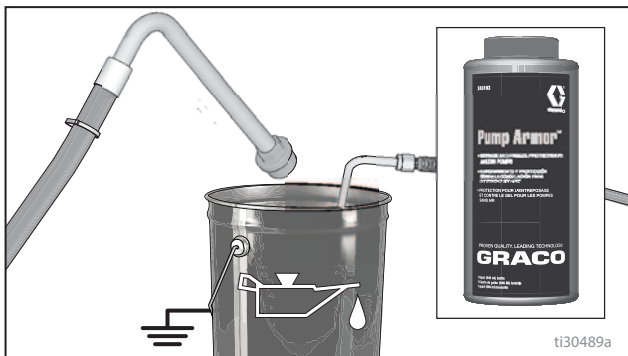

- 14. Close prime valve. Trigger gun into flushing pail to purge fluid from hose. Open prime valve.

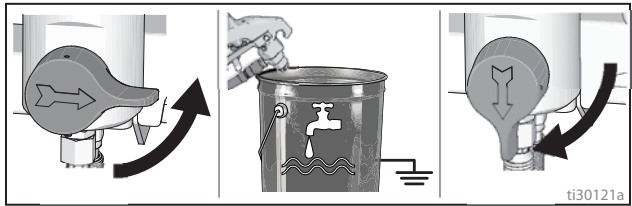

- 15. Install filter into filter bowl. Make sure plastic center tube is tightened securely.

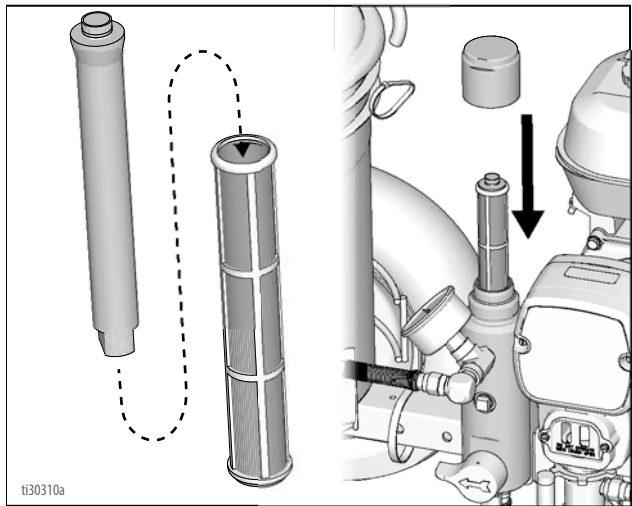

- 16. Clean Rac Tip, Rac Guard and gasket with a soft bristle brush to prevent part failure due to dried materials. Assemble parts and attach loosely onto gun.

- 17. Wipe striper, hose and gun with a rag soaked in water or mineral spirits.

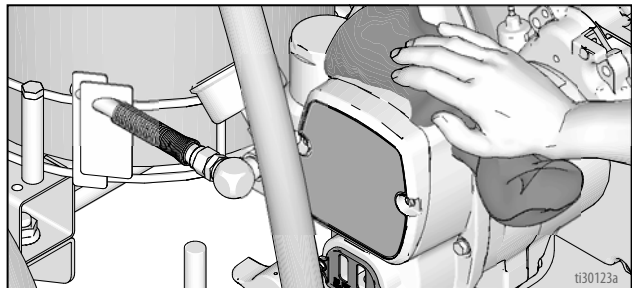

## Flushing Recommendations

<b>If you are going to:</b>	<b>Flush with:</b>	<b>Prime with:</b>	<b>Clean with:</b>	<b>Store with:</b>
Spray with new sprayer or sprayer that has been stored	Compatible solvent such as water or mineral spirits	Compatible paint, such as water-base or oil-base	Compatible solvent such as water or mineral spirits	Mineral spirits
Spray water-base paint	Warm, soapy water, then clean water	Water-base paint	Warm, soapy water, then clean water	Mineral spirits
Spray oil-base paint	Mineral spirits	Oil-base paint	Mineral spirits	Mineral spirits
Change water-base to oil-base paint	Warm, soapy water, then clean water	Mineral spirits	Mineral spirits	Mineral spirits
Change oil-base to water-base paint	Mineral spirits, soapy water, then clean water	Water-base paint	Warm, soapy water, then clean water	Mineral spirits
Change colors, same base	Compatible solvent such as water or mineral spirits			

# Troubleshooting



Problem	Cause	Solution	
Engine will not start	Engine switch is OFF	Turn engine switch ON	
	Engine is out of gasoline	Refill gas tank. Honda Engines Owner's Manual.	
	Engine oil level is low	Check oil level. Replenish oil, if necessary. Honda Engines Owner's Manual.	
	Spark plug is disconnected or damaged	Connect spark plug cable or replace spark plug	
	Cold engine	Use choke	
	Fuel shutoff lever is OFF	Move lever to ON position	
	Oil is seeping into combustion chamber	Remove spark plug. Pull starter 3 to 4 times. Clean or replace spark plug. Start engine. Keep sprayer upright to avoid oil seepage	
Engine operates, but displacement pump does not operate	Pump switch is OFF	Turn pump switch ON	
	Pressure setting too low	Turn pressure adjusting knob clockwise to increase pressure.	
	Fluid filter (104) is dirty	Clean filter. Page 18.	
	Tip is clogged	Clean tip. Page 17.	
	Displacement pump piston rod is stuck due to dried paint	Repair pump. Manual 309250.	
	Connecting rod is worn or damaged	Replace connecting rod. Page 24.	
	Drive housing is worn or damaged	Replace drive housing. Page 24.	
	Electrical power is not energizing clutch field		Check wiring connections. Page 32, 42.  Reference pressure control repair. Page 32.  Reference wiring diagram. Page 42.  With pump switch ON and pressure turned to MAXIMUM, use a test light to check for power between clutch test points on control board.  Remove clutch wires from control board and measure resistance across clutch coil. At 70° F, the resistance must be between 1.2+0.2 ohms; if not, replace pinion housing.  Have pressure control checked by authorized Graco dealer.
		Clutch is worn, damaged, or incorrectly positioned	Adjust or replace clutch. Page 27.
Pinion assembly is worn or damaged	Repair or replace pinion assembly. Page 27.		

<b>Problem</b>	<b>Cause</b>	<b>Solution</b>
Pump output is low	Strainer (56) is clogged	Clean strainer.
	Piston ball (206) is not seating	Service piston ball. Manual 309250.
	Piston packings are worn or damaged	Replace packings. Manual 309250.
	O-ring (227) in pump is worn or damaged	Replace o-ring. Manual 309250.
	Intake valve ball is not seating properly	Clean intake valve. Manual 309250.
	Intake valve ball is packed with material	Clean intake valve. Manual 309250.
	Engine speed is too low	Increase throttle setting.
	Clutch is worn or damaged	Adjust or replace clutch. Page 9.
	Pressure setting is too low	Increase pressure.
	Fluid filter (104) or tip is clogged or dirty	Clean filter or clear tip.
	Large pressure drop in hose with heavy materials	Use larger diameter hose and/or reduce overall length of hose. Use of more than 100 ft of 1/4 in. hose significantly reduces performance of sprayer. Use 3/8 in. hose for optimum performance (50 ft minimum).
Excessive paint leakage into throat packing nut	Throat packing nut is loose	Remove throat packing nut spacer. Tighten throat packing nut just enough to stop leakage.
	Throat packings are worn or damaged	Replace packings. Manual 309250.
	Displacement rod is worn or damaged	Replace rod. Manual 309250.
Fluid is spitting from gun	Air in pump or hose	Check and tighten all fluid connections. Reprime pump.
	Tip is partially clogged	Clear tip. Page 17.
	Fluid supply is low or empty	Refill fluid supply. Prime pump. Check fluid supply often to prevent running pump dry.
Pump is difficult to prime	Air in pump or hose	Check and tighten all fluid connections.  Reduce engine speed and cycle pump as slowly as possible during priming.
	Intake valve is leaking	Clean intake valve. Be sure ball seat is not nicked or worn and that ball seats well. Reassemble valve.
	Pump packings are worn	Replace pump packings. Manual 309250.
	Paint is too thick	Thin the paint according to the supplier's recommendations
	Engine speed is too high	Decrease throttle setting before priming pump.
Clutch squeaks each time clutch engages	Clutch surfaces are not matched to each other when new and may cause noise	Clutch surfaces need to wear into each other. Noise will dissipate after a day of run time.
High engine speed at no load	Misadjusted throttle setting	Reset throttle to 3300 engine rpm at no load
	Worn engine governor	Replace or service engine governor

# Displacement Pump

## Removal



1. Stop pump with piston rod (201) in its lowest position.
2. Perform **Pressure Relief Procedure**, page 9.
3. Loosen two screws (108) and remove pump rod cover (107).

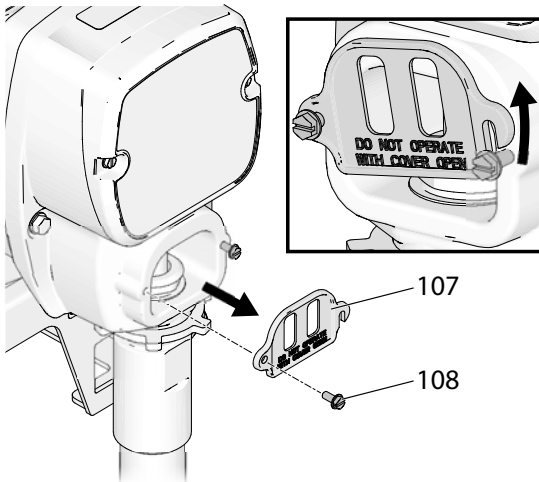

ti30159a

4. Remove hose (118) and suction hose (57). Use screwdriver; push retaining spring up; push out pin (31).

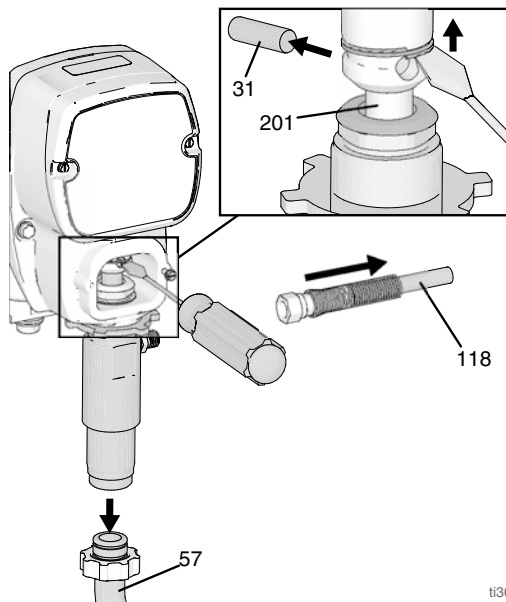

ti30160a

5. Loosen jam nut by hitting firmly with a hammer. Unscrew pump.

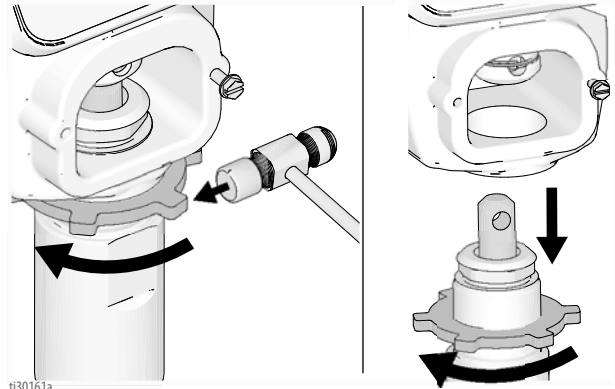



ti30161a

## Repair

See manual 309250 for pump repair instructions.



## Installation

				
<p>If pin works loose, parts could break off due to force of pumping action. Parts could project through the air and result in serious injury or property damage. Make sure pin and retaining spring are properly installed.</p>				

### NOTICE

If the pump jam nut loosens during operation, the threads of the bearing housing and drive train will be damaged. Tighten jam nut as specified.

1. Pull piston rod out distance shown. Screw in pump until holes in connecting rod and piston rod align.

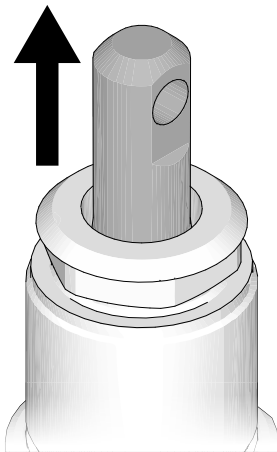

ti30163a

2. Push pin (31) into hole. Push retaining ring spring into groove all the way around connecting rod.

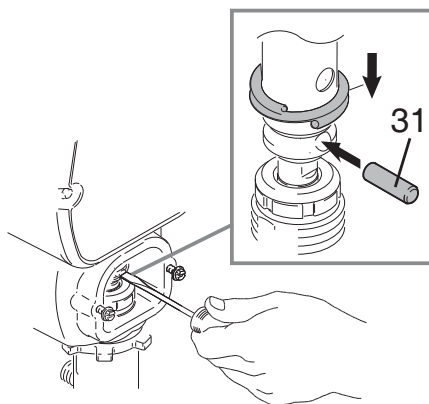

ti30130a

3. Screw jam nut down onto pump until nut stops. Screw pump up into drive housing until top threads of pump are flush with drive housing face. Back off pump and jam nut to align pump outlet to side. Tighten jam nut by hand, then tap 1/8 to 1/4 turn with a 20 oz (maximum) hammer to approximately 75 ±5 ft-lb (102 N·m). Connect hose (118) and suction hose (57).

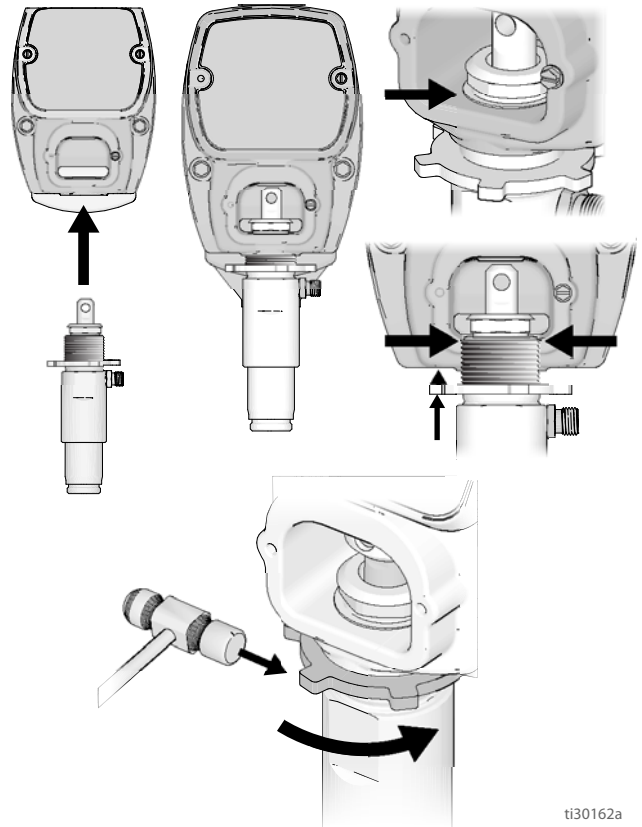

ti30162a

4. Fill packing nut with TSL until fluid flows onto the top of seal. Install pump rod cover (107).

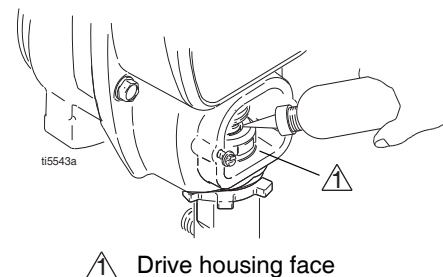

ti5543a

⚠ Drive housing face

# Drive Housing and Connecting Rod

## Removal



1. Perform **Pressure Relief Procedure**, page 9.
2. Remove screws (108) and front cover (52).
3. Remove pump. Refer to **Displacement Pump, Removal**, page 24.
4. Remove four screws (34) from drive housing (43).

### NOTICE

Thrust washers may stick to grease inside of drive housing. Do not lose or misplace.

5. Pull connecting rod (29) and lightly tap lower rear of drive housing (43) with plastic mallet to loosen from pinion housing (44). Pull drive housing and connecting rod assembly off pinion housing.
6. Inspect crank (47) and connecting rod (29) for excessive wear and replace parts as needed.

## Installation

1. Evenly lubricate inside of bronze bearing (C) in drive housing (43) with high-quality motor oil. Liberally pack top roller bearing (E), lower bearing (D) inside connecting rod (29) with bearing grease.
2. Assemble connecting rod (29) to drive housing (43). Rotate connecting rod to lowest position.
3. Apply grease to washers 46, 49 and 48. Install in order.
4. Lubricate gears with 0.26 pint of 110293 grease (supplied with drive housing). Pack grease evenly around gears.
5. Clean mating surfaces of pinion and drive housings.
6. Align connecting rod with crank (47) and carefully align locating pins in drive housing (43) with holes in pinion housing (44). Push drive housing onto pinion housing or tap into place with plastic mallet.

### NOTICE

DO NOT use drive housing screws (34) to align or seat bearing housing with drive housing. Align these parts with locating pins, to avoid premature bearing wear.

7. Install screws (34) in drive housing.
8. Install pump. Refer to **Displacement Pump, Installation**, page 25.
9. Install front cover (52) with two screws (108).

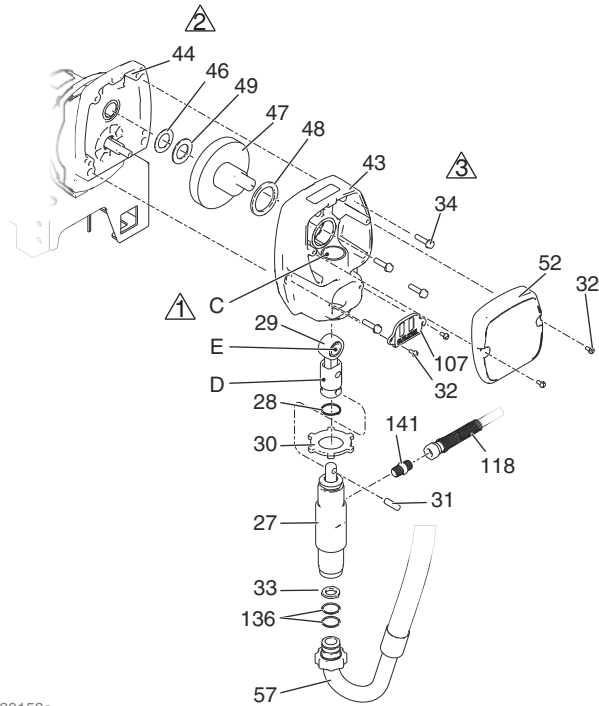

- Oil
- Pack with bearing grease 110293
- Torque to 130 - 150 in-lb (14 - 16.9 N.m)

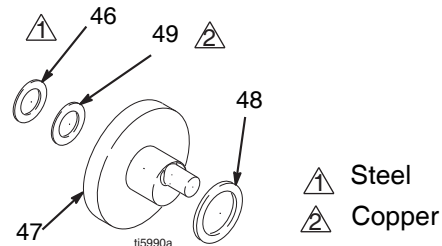

# Pinion Assembly/Clutch Armature/Clamp

## Pinion Assembly/Clutch Armature Removal

### Pinion Assembly

If pinion assembly (44) is not removed from clutch housing (45), do 1. through 3. Otherwise, start at 4.

1. Perform **Pressure Relief Procedure**, page 9.
2. Remove drive housing; page 26.
3. Disconnect clutch (+) and clutch (-) connectors from wire harness located under sprayer cart.
4. Remove four screws (34) and pinion assembly (44).

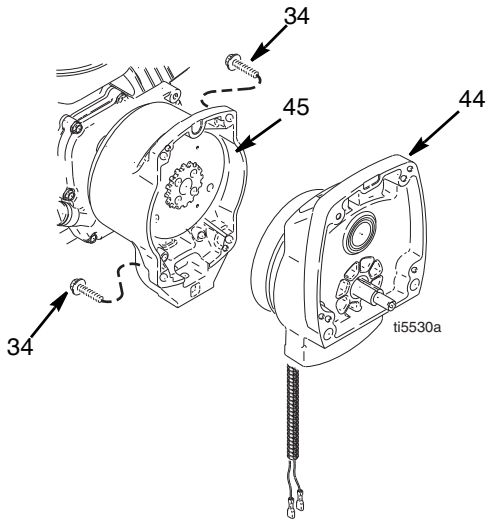

5. Place pinion assembly (44) on bench with rotor side up.

6. Remove four screws (42) and lock washers (35). Install two screws in threaded holes (E) in rotor. Alternately tighten screws until rotor comes off.

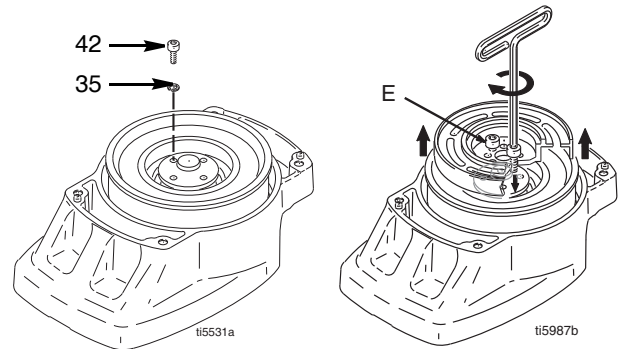

7. Remove retaining ring (44d).
8. Turn pinion assembly over and tap pinion shaft (44c) out with plastic mallet.

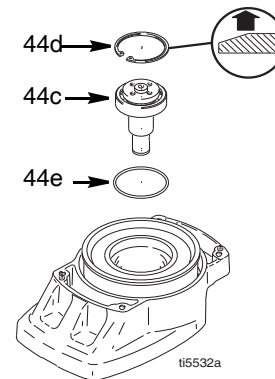

## Clutch Armature

9. Use an impact wrench or wedge something between clutch armature (39) and clutch housing to hold engine shaft during removal.
10. Remove four screws (36) and lock washers (35).
11. Remove armature (39).

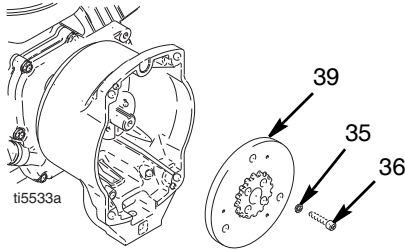

## Pinion Assembly

6. Install o-ring (44e).
7. Tap pinion shaft (44c) in with plastic mallet.
8. Install retaining ring (44d) with beveled side facing up.
9. Place pinion assembly on bench with rotor side up.
10. Apply locktite to screws. Install four screws (42) and lock washers (35). Alternately torque screws to 125 in-lb until rotor is secure. Use threaded holes to hold rotor.
11. Install pinion assembly (44) with four screws (18).
12. Connect clutch (+) and clutch (-) connectors to wire harness.

## Installation

### Clutch Armature

1. Lay two stacks of two dimes on smooth bench surface.
2. Lay armature (39) on two stacks of dimes.
3. Press center of hub down to bench surface.

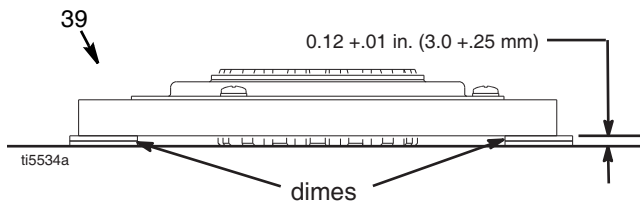

4. Install armature (39) on engine drive shaft.
5. Install four screws (36) and lock washers (35) with torque of 125 in-lb.

## Clamp Removal

1. Remove engine. See **Engine Removal**, page 30.
2. Drain gasoline from tank according to Honda manual.
3. Tip engine on side so gas tank is down and air cleaner is up.
4. Loosen two screws (36) on clamp (38),
5. Push screwdriver into slot in clamp (38) and remove clamp.

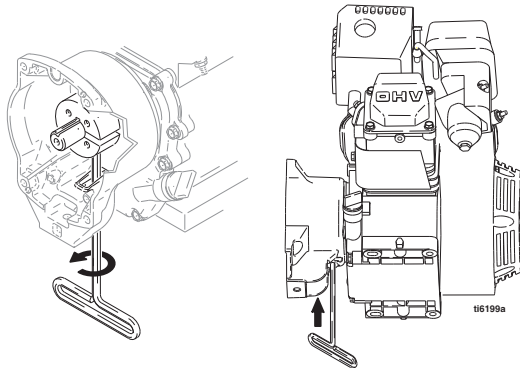

## Clamp Installation

1. Install engine shaft key (37)
2. Tap clamp (38) onto engine shaft (A). Maintain dimension shown note 2. Chamfer must face engine.
3. Check dimension: Place rigid, straight steel bar (B) across face of clutch housing (45). Use accurate measuring device to measure distance between bar and face of clamp. Adjust clamp as necessary. Torque two screws (36) to 125 ±10 in-lb (14 ±1.1 N·m).

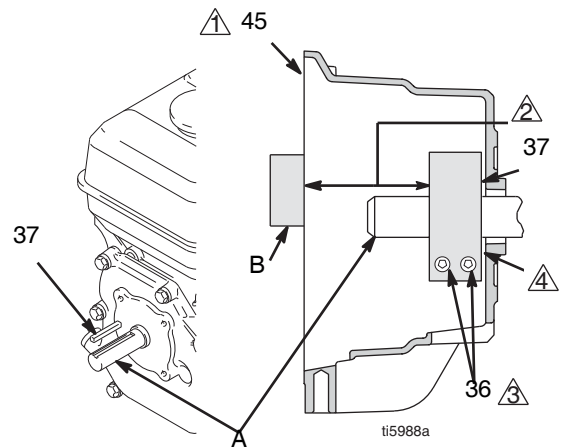

⚠ Face of clutch housing

Ⓜ 1.550 ±.010 in. (39.37±.25 mm)

Ⓜ Torque to 125 ±.10 in-lb (14 ±1.1 N·m)

⚠ Chamfer this side

# Clutch Housing

## Removal

1. Remove clamp. Do **Clamp Removal**, page 29.
2. Remove four screws (51) and lock washers (50) which hold clutch housing (45) to engine.
3. Remove screw (145) from under mounting plate.
4. Pull off clutch housing (45).

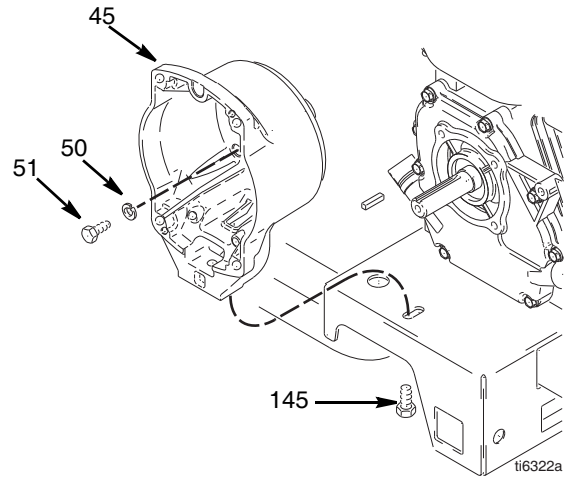

## Installation

1. Push on clutch housing (45).
2. Install four capscrews (51) and lock washers (56) and secure clutch housing (45) to engine. Torque to 200 in-lb (22.6 N·m).
3. Install screw (145) from beneath mounting plate. Torque to 26 ft-lb (35.2 N·m).

# Engine

## Removal

**NOTE:** All service to the engine must be performed by an authorized HONDA dealer.

1. Remove **Pinion Assembly/Clutch Armature/Clamp** and **Clutch Housing**, as instructed on pages 27, 29 and 30.
2. Disconnect all necessary wiring.
3. Remove two locknuts (111) and screws (110) from base of engine.
4. Lift engine carefully and place on work bench.

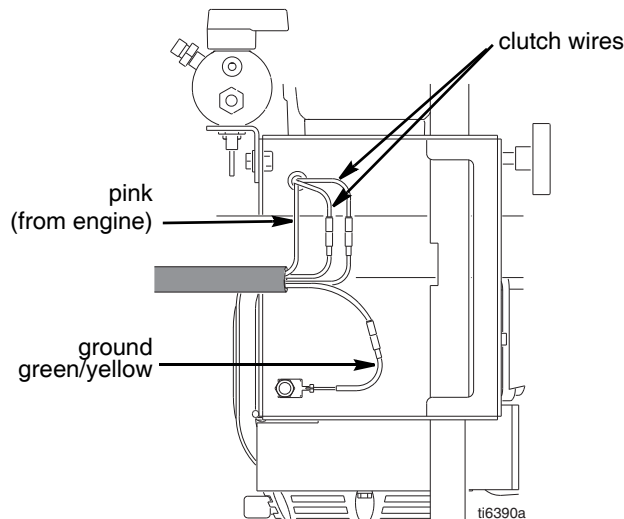
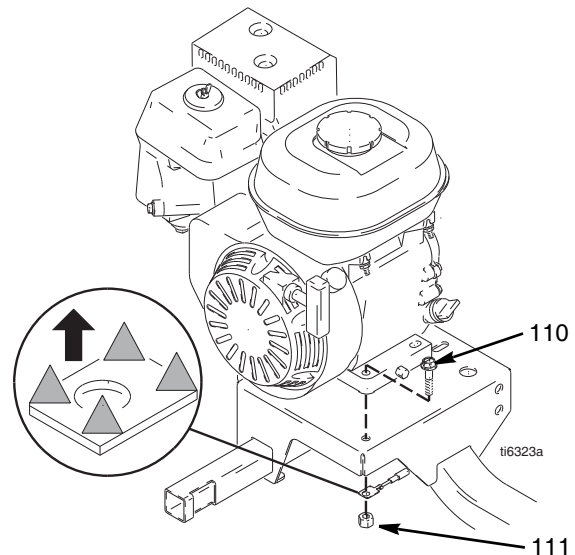

## Installation

1. Lift engine carefully and place on cart.
2. Install two screws (110) in base of engine and secure with locknuts (111). Torque to 20 ft-lb (27.12 N·m).
3. Connect all necessary wiring.
4. Install **Pinion Assembly/Clutch Armature/Clamp** and **Clutch Housing**, as instructed on pages 28, 29 and 30.

# Pressure Control Transducer

## Removal

1. Remove two screws (108) and open cover (62a).
2. Disconnect transducer (155) lead from control board (62e).
3. Pull transducer connector through strain relief bushing (151).
4. Remove transducer and o-ring (99) from filter housing (67).

## Installation

1. Install o-ring (99) and transducer (155) in filter housing (67). Torque to 35 - 45 ft-lb.
2. Install transducer connector and strain relief bushing in control housing.
3. Connect lead (155) to control board (62e).
4. Close cover (62a) and secure with two screws (108).





# Pressure Adjust Potentiometer

## Removal

1. Remove two screws (108) and open cover (62a).
2. Disconnect potentiometer (62b) lead from control board (62e).
3. Loosen set screws on potentiometer knob (62c) and remove knob, shaft nut, lock washer and potentiometer (62b).
4. Remove spacer (62g) from potentiometer.

## Installation

1. Install spacer (62g) on potentiometer (62b).
2. Install potentiometer, shaft nut, lock washer and potentiometer knob (62c).
  - a. Turn potentiometer shaft clockwise to internal stop. Assemble potentiometer knob (62c) to strike pin on cover (62a).
  - b. After adjustment of step a., tighten both set screws in knob 1/4 to 3/8 turn after contact with shaft.
3. Connect potentiometer (62b) lead to control board (62e).
4. Close cover (62a) and secure with two screws (108).

# Control Board

## Removal

1. Remove two screws (108) and open cover (62a).
2. Disconnect engine and ground wires from wire harness (66).
3. Disconnect at control board (62e):
  - Lead from potentiometer (62b)
  - Lead from transducer (155)
  - Lead from ON/OFF switch (62d)
  - Clutch wires
4. Remove four screws (62f) and control board (62e).

## Installation

1. Install control board (62e) with four screws (62f).
2. Connect at control board (62e):
  - Clutch wires
  - Lead from ON/OFF switch (62d)
  - Lead from transducer (155)
  - Lead from potentiometer (62b)
3. Connect engine and ground wires.
4. Close cover (62a) and secure with two screws (108).



# Parts List - 25M224

Ref.	Part	Description	Qty	Ref.	Part	Description	Qty
1	17N510	FRAME, LL	1	90	15F047	CONTROL, box	1
2	119542	WHEEL, small	1	91	113665	SCREW, cap, hex hd	1
3	119543	WHEEL, large	2	92	114802	WIRE, stop	1
4	15F127	FORK, painted	1	93	119554	NUT, lock, nylon, thin pattern	4
5	119532	BEARING, flanged	2	94	24Z284	BAR, handle, LL	1
6	15E780	PIN, fork	1	96	114271	STRAP, hose wrap	1
7	15E773	DISK, adjuster	1	97	116935	SCREW, cap, flng hd	2
8	15E792	PIN, lever	1	108	128978	SCREW, 8-32 hex washer head	6
9	101566	NUT, lock	3	110	112960	SCREW, flange, hex	2
10	114682	SPRING, compression	1	111	110838	NUT, lock	2
11	108471	KNOB, pronged	1	112	122669	WASHER, flat, extra thick	1
13	15E748	BRACKET, manifold	1	114	110963	SCREW, cap, flng hd	3
14	287682	LEVER, caster, includes 26	1	115	111040	NUT, lock, insert, nylock, 5/16 in.	1
15	108879	ENGINE, gasoline, 4.0 hp	1	129	101550	SCREW, cap, sch	2
	25P294	ENGINE, gasoline, 40HP (China only)	1	130	278723	GASKET, pail	1
16	238049	FLUID, TSL, 4 oz.	1	131	15C871	CAP, leg	2
18	249080	HOSE, coupled, 1/4 in. x 50 ft, nickel	1	132	100731	WASHER	2
19	24U241	KIT, pail cover	1	137	119579	CONDUCTOR, ground	1
25	108538	SCREW, cap, flathead	2	143	17H684	LABEL, LL3400	1
26	111016	BEARING, flange	1	144▲	194126	LABEL, warning	1
53	194310	LEVER, actuator	2	147	107257	SCREW, thread forming, hex hd	1
54	115077	PAIL, plastic	1	148	237686	WIRE, ground assembly w/ clamp	1
55	116139	GRIP, handle	2	149▲	17K394	LABEL, safety, warning, fire & explosion	1
59	15E992	CABLE, gun	1	150▲	16P136	LABEL, safety, warning	1
60	15E993	ROD, brake	1	151	15F928	BUSHING, strain relief	1
62	287565	COVER, control box, assy	1	153	111025	GASKET, polypropylene	1
64	119563	WASHER, belleville	4	170	120151	PLUG, tube	2
65	15E996	SPACER, wheel	2	172	117727	CLIP, wire	1
66	15E995	HARNESS, wiring, control	1	183▲	16W503	LABEL, safety, ground symbol	1
72	17J407	BRACKET, support, gun	1	184▲	17K392	LABEL, safety, warning, injection	1
74	241445	CABLE, caster	1	▲	222385	LABEL, warning, medical alert (not shown)	1
81	195134	SPACER, ball, guide	1	192	24Z605	AXLE, weldment	1
82	198891	BRACKET, mounting	1	194	112731	NUT, hex, flanged	4
83	198931	BEARING	1	201	129528	GROMMET, split, 1" hole	1
84	113961	SCREW, cap, hex hd	1				
85	867517	SCREW, hex head, 3/8-16 x 3.5"	4				
86	111802	SCREW	4				
87	111801	SCREW, cap, hex, hd	4				
89	17N536	HOLDER, bucket	2				

▲ Replacement Danger and Warning labels, tags, and cards are available at no cost.

# Parts Drawing

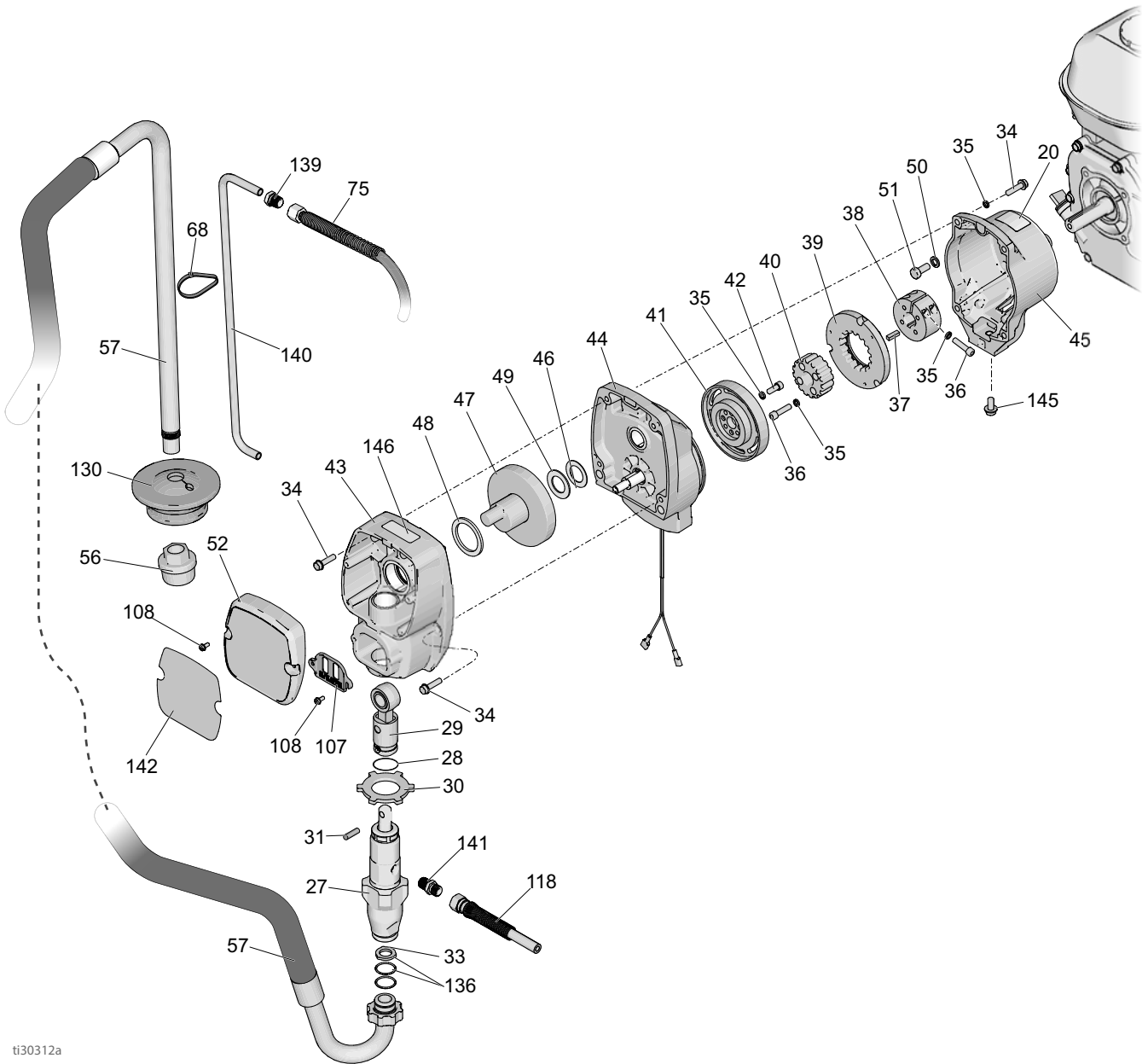

ti30312a

## Parts List - 25M224

Ref.	Part	Description	Qty	Ref.	Part	Description	Qty
20	16D576	LABEL, made in USA	1	49	107434	BEARING, thrust	1
27	246428	PUMP, displacement	1	50	100214	WASHER, lock	4
28	196750	SPRING, retaining	1	51	108842	SCREW, cap, hex hd	4
29	287053	ROD, connecting	1	52	287487	COVER, front, painted	1
30	195150	NUT, jam, pump	1	56	246385	STRAINER, 7/8-14 unf	1
31	196762	PIN, straight	1	57	17M875	HOSE, suction, includes 33, 136	1
33†	115099	WASHER	1	68	404989	STRAP, tie	6
34	119426	SCREW, mach, hex washer hd	8	75	249232	HOSE, cpld, 1/4 in. X 3.0 ft	1
35*	105510	WASHER, lock, spring (hi-collar)	10	107	15B589	COVER, pump rod	1
36*	108803	SCREW, hex, socket head	6	118	249149	HOSE, coupled, 1/4 in. X 22.25 in.	1
37	183401	KEY, parallel	1	136†	117559	O-RING	2
38	193680	COLLAR, shaft	1	139	196180	BUSHING	1
39*		ARMATURE, clutch, 4 in.	1	140	16X071	TUBE, drain	1
40*		HUB, armature	1	141	196181	FITTING, nipple	2
41*		ROTOR, clutch, 4 in.	1	142	17H685	LABEL, pump, LL3400	1
42*	101682	SCREW, cap, sch	4	145	112395	SCREW, cap, flng hd	1
43	287483	HOUSING, drive, includes 34	1	146▲	290228	LABEL, warning	1
44	287376	HOUSING, pinion	1				
45	15E535	HOUSING, clutch, machine	1				
46	116074	WASHER, thrust	1				
47	287484	CRANK, GMAX 3400, includes 46, 48, 49	1				
48	180131	BEARING, thrust	1				

▲ Replacement Danger and Warning labels, tags, and cards are available at no cost.

\* Included in Clutch Replacement Kit 241109

† Included in Suction Hose Kit 17M875

# Parts Drawing and List - Pinion Housing

## Ref No. 44: Pinion Housing

Ref.	Part	Description	Qty
44	287376	PINION HOUSING	1
44a	287482	KIT, repair, coil	1
44b	105489	PIN	2
44c*	287485	PINION SHAFT	1
44d*	113094	RETAINING RING, large	1
44e*	165295	O-RING, packing	1

\* May be ordered separately

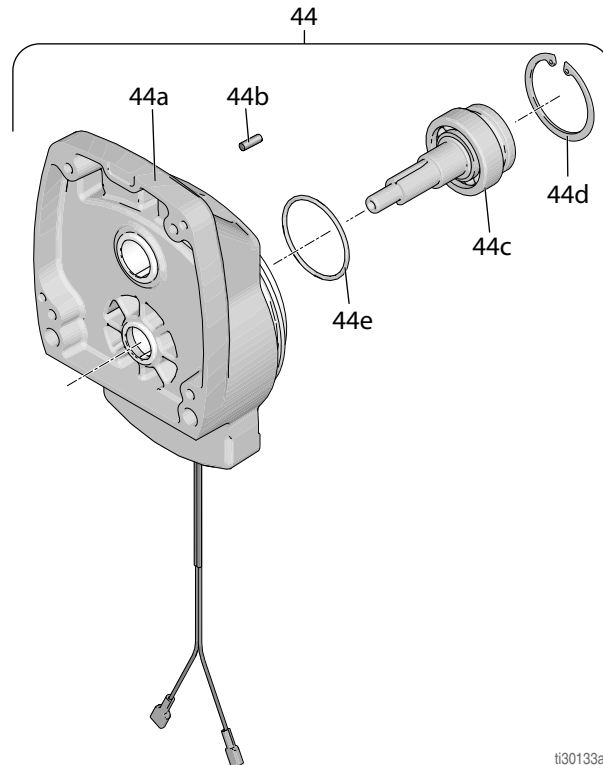

ti30133a

# Gun Arm Parts

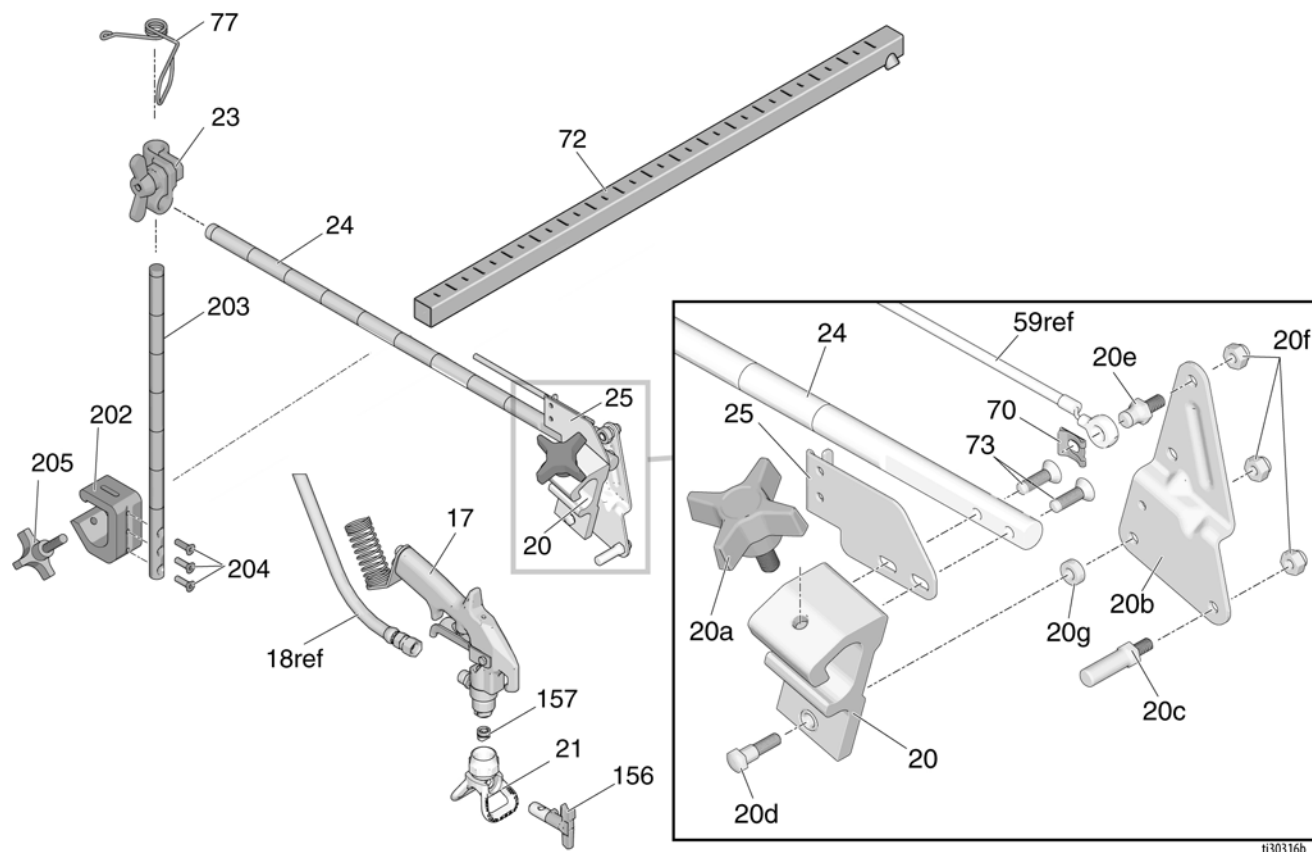

Ref	Part	Description	Qty	Ref	Part	Description	Qty
17	248157	GUN, flex	1	72	17J407	BRACKET, support gun	1
20	15F216	HOLDER, gun	1	73	119647	SCREW, cap, socket, flthd	2
20a*	15F750	KNOB, holder, gun	1	77	188135	GUIDE, cable	1
20b*	15F214	LEVER, actuator	1	156	LL5319	TIP, spray, striping, includes 157	1
20c*	15F209	STUD, pull trigger	1		*17H720	STRAP, tie, 5 in.	3
20d*†	17J575	FASTENER, special	1	202	17J424	BAR, height, adjustment, assy, includes 203, 204, 205	1
20e*	17H673	STUD, cable	1	203	17J139	BAR, gun, holder	1
20f*†	102040	NUT, lock	3	204	113428	SCREW, machine	3
20g*†	17J576	SPACER, special	1	205	108471	KNOB, pronged	1
21	243161	GUARD, Rac V	1				
23	24Y645	KIT, clamp	1				
24	17J145	ARM, holder, gun	1				
25*	15F213	BRACKET, cable	1				
70	*126111	RETAINER, CirClip, external, 8mm	1				

\* Included in Gun Holder Repair Kit 25A528

† Included in 4-finger Gun Kit 24Y991

# Pressure Control/Filter Assembly

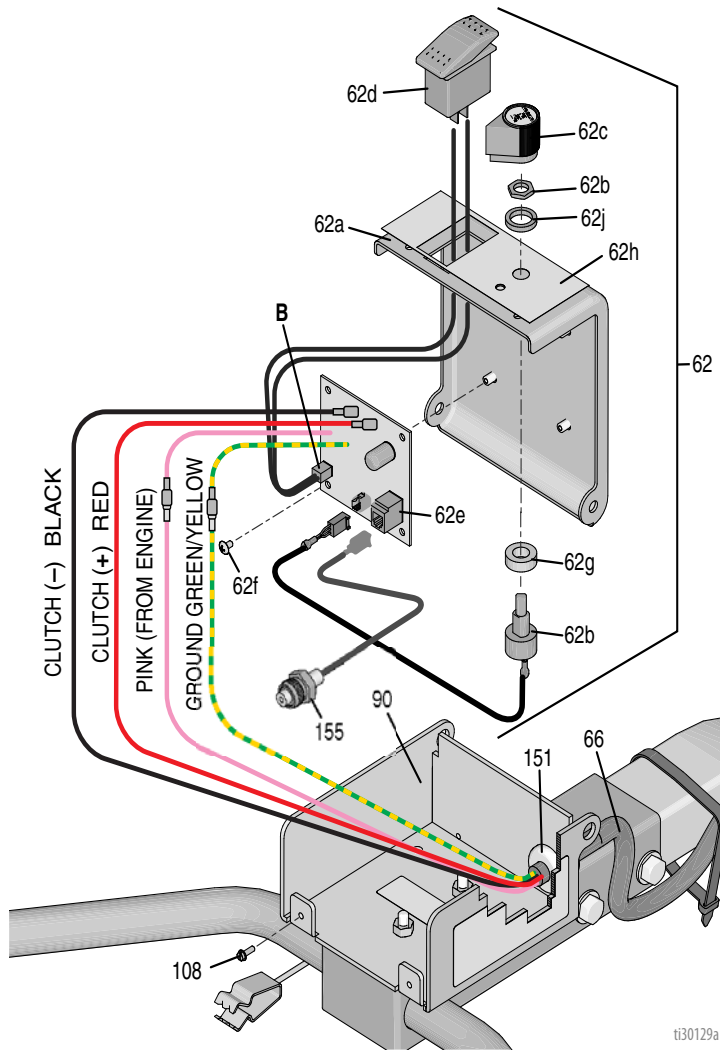

ti30129a

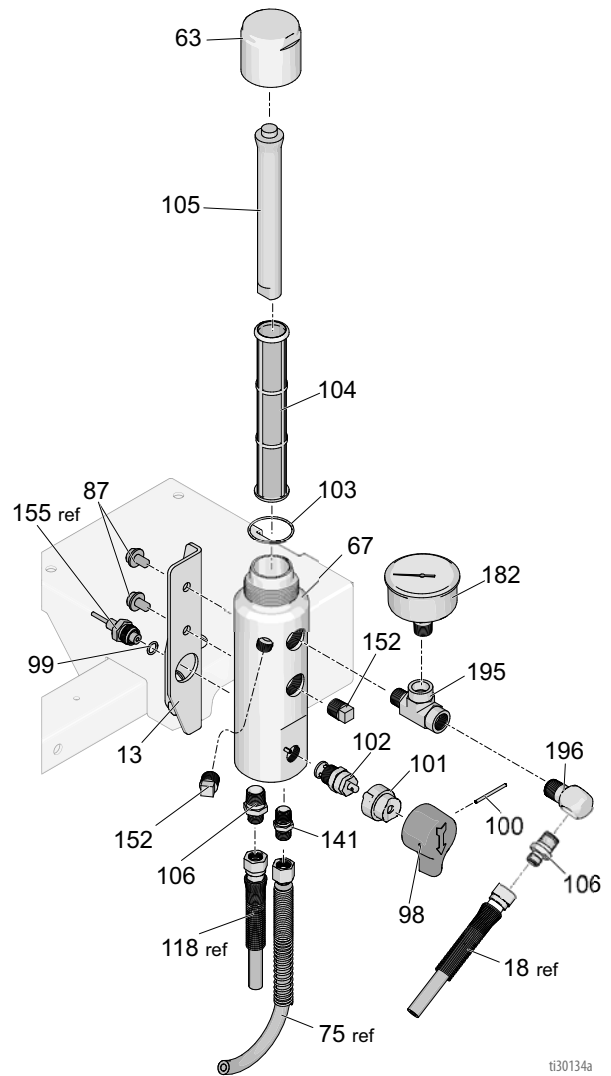



## Parts List - Pressure Control/Filter Assembly

Ref	Part	Description	Qty	Ref	Part	Description	Qty
13	15E748	BRACKET, manifold	1	100*	15C972	PIN, grooved	1
62a	15E991	COVER, control box	1	101*	224807	BASE, valve	1
62b	256219	POTENTIOMETER	1	102*	239914	VALVE, drain	1
62c	116167	KNOB, potentiometer	1	103*	117285	O-RING	1
62d	116752	SWITCH, rocker	1	104*	243984	FILTER, fluid	1
62e	287486	BOARD, control,	1	105*	15C766	TUBE, diffusion	1
62f	113045	SCREW, sems, mach, phillips, truss	4	106	196177	ADAPTER, nipple	2
62g	198650	SPACER, shaft	2	141	196181	FITTING, nipple	1
62h	15F540	LABEL, controls	1	152*	15G331	PIPE, plug, sst	2
62j	15C973	GASKET	1	155*	15F782	HARNESS, transducer, line striper	1
63*	287285	CAP, manifold, includes 103, 105	1	182	804582	GAUGE, pressure fluid	1
67*	17K166	MANIFOLD, filter	1	195	124490	FITTING, tee	1
87	111801	SCREW, cap, hex hd	4	196	196179	FITTING, elbow	1
98*	15C780	HANDLE	1				
99*	111457	O-RING	1				

\* Included in Filter Repair Kit 24Z867

# Pressure Control Wiring Diagram

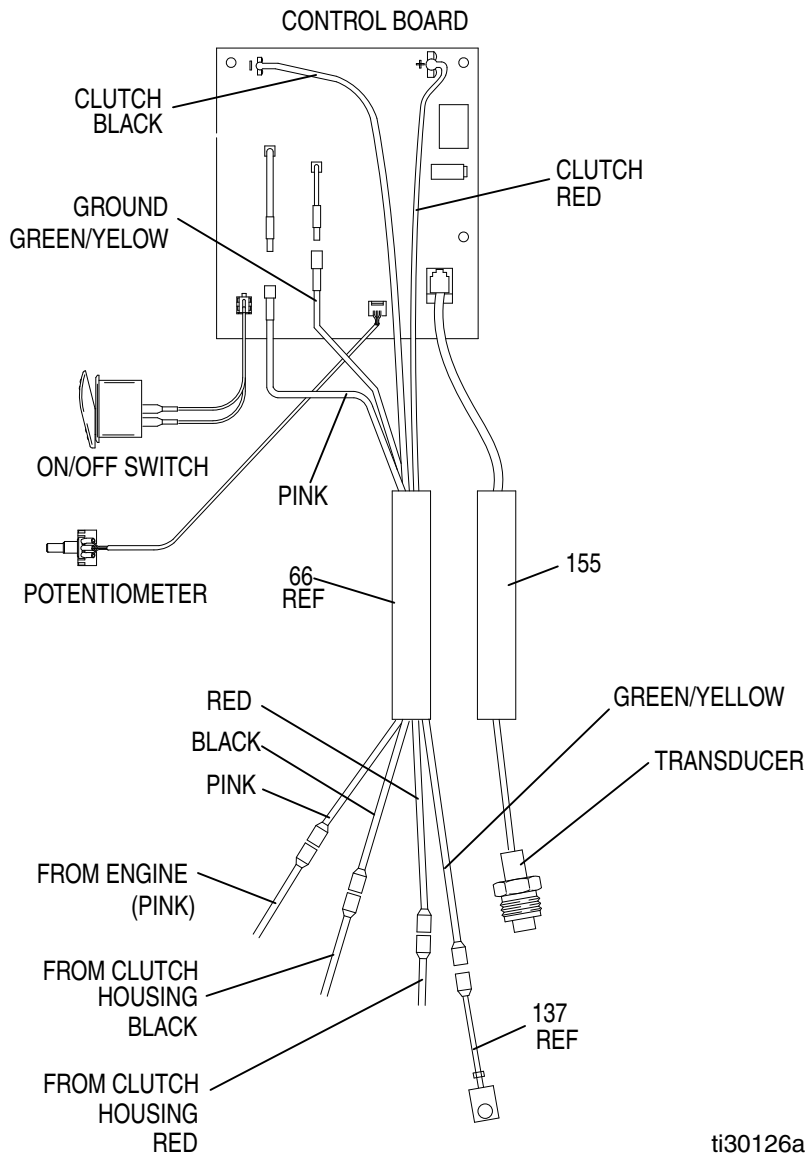

ti30126a

# Technical Data

<b>LineLazer 3400 (Model 25M224)</b>		
	<b>US</b>	<b>Metric</b>
Honda GX120 engine		
SAE J1995 @ 3600 rpm	4.0 Horsepower	
Maximum working pressure	3300 psi	22.8 MPa, 228 bar
Maximum delivery	0.75 gpm	2.84 lpm
Maximum tip size	1 gun with 0.027 in. tip	
Inlet paint strainer	12 mesh (893 micron) stainless steel screen, reusable	
Outlet paint strainer	60 mesh (250 micron) stainless steel screen, reusable	
Pump inlet size	1.0 in. diameter	
Fluid outlet size	0.25 in. diameter	
Noise Level		
Sound power, per ISO 3741	95.4 dBA	
Sound pressure, per ISO 3741	91.0 dBA	
Vibration, per ISO 5349		
Left-hand	260 in/s <sup>2</sup>	6.60 m/s <sup>2</sup>
Right-hand	225 in/s <sup>2</sup>	5.72 m/s <sup>2</sup>
Wetted parts	stainless steel, PTFE, leather, nylon, zinc-plated and nickel-plated carbon steel, tungsten carbide, chrome plating, UHMWPE, acetal, polyethylene,	
<b>Dimensions (25M224)</b>		
Weight (dry, without packaging)	160.0 lb.	72.5 kg
Height Handles Down	39.4 in.	100.0 cm
Height Handles Up	41.3 in.	104.8 in.
Length Handles Down	66.3 in.	168.4 cm
Length Handles Up	68.0 in.	172.7 cm
Width	26.0 in.	66.0 cm
<b>Gun</b>		
Maximum Working Pressure	5000 psi	345, 3.45 (bar, MPa)
Weight (with tip and guard)	18 oz.	510 g
Inlet	1/4 npsm male	
Maximum material temperature	120°F	50°C

## California Proposition 65

### CALIFORNIA RESIDENTS

 **WARNING:** Cancer and reproductive harm – [www.P65warnings.ca.gov](http://www.P65warnings.ca.gov).

# Graco Standard Warranty

Graco warrants all equipment referenced in this document which is manufactured by Graco and bearing its name to be free from defects in material and workmanship on the date of sale to the original purchaser for use. With the exception of any special, extended, or limited warranty published by Graco, Graco will, for a period of twelve months from the date of sale, repair or replace any part of the equipment determined by Graco to be defective. This warranty applies only when the equipment is installed, operated and maintained in accordance with Graco's written recommendations.

This warranty does not cover, and Graco shall not be liable for general wear and tear, or any malfunction, damage or wear caused by faulty installation, misapplication, abrasion, corrosion, inadequate or improper maintenance, negligence, accident, tampering, or substitution of non-Graco component parts. Nor shall Graco be liable for malfunction, damage or wear caused by the incompatibility of Graco equipment with structures, accessories, equipment or materials not supplied by Graco, or the improper design, manufacture, installation, operation or maintenance of structures, accessories, equipment or materials not supplied by Graco.

This warranty is conditioned upon the prepaid return of the equipment claimed to be defective to an authorized Graco distributor for verification of the claimed defect. If the claimed defect is verified, Graco will repair or replace free of charge any defective parts. The equipment will be returned to the original purchaser transportation prepaid. If inspection of the equipment does not disclose any defect in material or workmanship, repairs will be made at a reasonable charge, which charges may include the costs of parts, labor, and transportation.

**THIS WARRANTY IS EXCLUSIVE, AND IS IN LIEU OF ANY OTHER WARRANTIES, EXPRESS OR IMPLIED, INCLUDING BUT NOT LIMITED TO WARRANTY OF MERCHANTABILITY OR WARRANTY OF FITNESS FOR A PARTICULAR PURPOSE.**

Graco's sole obligation and buyer's sole remedy for any breach of warranty shall be as set forth above. The buyer agrees that no other remedy (including, but not limited to, incidental or consequential damages for lost profits, lost sales, injury to person or property, or any other incidental or consequential loss) shall be available. Any action for breach of warranty must be brought within two (2) years of the date of sale.

**GRACO MAKES NO WARRANTY, AND DISCLAIMS ALL IMPLIED WARRANTIES OF MERCHANTABILITY AND FITNESS FOR A PARTICULAR PURPOSE, IN CONNECTION WITH ACCESSORIES, EQUIPMENT, MATERIALS OR COMPONENTS SOLD BUT NOT MANUFACTURED BY GRACO.** These items sold, but not manufactured by Graco (such as electric motors, switches, hose, etc.), are subject to the warranty, if any, of their manufacturer. Graco will provide purchaser with reasonable assistance in making any claim for breach of these warranties.

In no event will Graco be liable for indirect, incidental, special or consequential damages resulting from Graco supplying equipment hereunder, or the furnishing, performance, or use of any products or other goods sold hereto, whether due to a breach of contract, breach of warranty, the negligence of Graco, or otherwise.

## Graco Information

For the latest information about Graco products, visit [www.graco.com](http://www.graco.com).

For patent information, see [www.graco.com/patents](http://www.graco.com/patents).

**TO PLACE AN ORDER**, contact your Graco distributor or call 1-800-690-2894 to identify the nearest distributor.

*All written and visual data contained in this document reflects the latest product information available at the time of publication. Graco reserves the right to make changes at any time without notice.*

Original instructions. This manual contains English. MM 3A4587

**Graco Headquarters:** Minneapolis

**International Offices:** Belgium, China, Japan, Korea

**GRACO INC. AND SUBSIDIARIES • P.O. BOX 1441 • MINNEAPOLIS MN 55440-1441 • USA**  
**Copyright 2016, Graco Inc. All Graco manufacturing locations are registered to ISO 9001.**

[www.graco.com](http://www.graco.com)

Revision E, March 2021