

Instruction Manual
for AC Generators
English

QAS 60-80-100 Pd

QAS 60-80-100 Pd

Instruction Manual for AC Generators

Instruction manual	5
Circuit diagrams	107

Original instructions

Printed matter N°
2954 3690 01

11/2010



ATLAS COPCO - PORTABLE AIR DIVISION
www.atlascopco.com

Warranty and Liability Limitation

Use only authorized parts.

Any damage or malfunction caused by the use of unauthorized parts is not covered by Warranty or Product Liability.

The manufacturer does not accept any liability for any damage arising from modifications, additions or conversions made without the manufacturer's approval in writing.

Neglecting maintenance or making changes to the setup of the machine can result in major hazards, including fire risk.

While every effort has been made to ensure that the information in this manual is correct, Atlas Copco does not assume responsibility for possible errors.

Copyright 2010, Atlas Copco Airpower n.v., Antwerp, Belgium.

Any unauthorized use or copying of the contents or any part thereof is prohibited.

This applies in particular to trademarks, model denominations, part numbers and drawings.



Congratulations on the purchase of your AC generator. It is a solid, safe and reliable machine, built according to the latest technology. Follow the instructions in this booklet and we guarantee you years of troublefree operation. Please read the following instructions carefully before starting to use your machine.

While every effort has been made to ensure that the information in this manual is correct, Atlas Copco does not assume responsibility for possible errors. Atlas Copco reserves the right to make changes without prior notice.

Contents

Safety precautions for portable generators6	Maintenance61	Options available for QAS 60, QAS 80 and QAS 100 units72
Leading particulars 13	Maintenance schedule61	Circuit diagrams.....72
General description 13	Engine maintenance.....63	Overview of the electrical options.....72
Bodywork 15	(*) Measuring the alternator insulation resistance.....63	Description of the electrical options73
Markings..... 15	Engine fuel specifications63	Overview of the mechanical options84
Drain plugs and filler caps 16	Engine oil specifications63	Description of the mechanical options .84
Control and indicator panel Qc1002™.. 17	Engine oil level check.....64	Technical specifications86
Control and indicator panel Qc2002™..25	Engine oil and oil filter change.....64	Technical specifications for QAS 60 units86
Control and indicator panel Qc4002™..37	Engine coolant specifications65	Technical specifications for QAS 80 units92
Output terminal board54	Coolant check.....66	Technical specifications for QAS 100 units98
Spillage free54	Storage of the generator67	Conversion list of SI units into British units 104
Operating instructions55	Storage67	Dataplate 104
Installation.....55	Preparing for operation after storage ...67	Disposal 105
Connecting the generator55	Checks and trouble shooting68	
Before starting57	Checking voltmeter P468	
Operating Qc1002™.....57	Checking ammeters P1, P2 and P3.....68	
Operating Qc2002™.....58	Alternator troubleshooting69	
Operating Qc4002™60	Engine trouble shooting.....70	

Safety precautions for portable generators

To be read attentively and acted accordingly before towing, lifting, operating, performing maintenance or repairing the generator.

Introduction

The policy of Atlas Copco is to provide the users of their equipment with safe, reliable and efficient products. Factors taken into account are among others:

- the intended and predictable future use of the products, and the environments in which they are expected to operate,
- applicable rules, codes and regulations,
- the expected useful product life, assuming proper service and maintenance,
- providing the manual with up-to-date information.

Before handling any product, take time to read the relevant instruction manual. Besides giving detailed operating instructions, it also gives specific information about safety, preventive maintenance, etc.

Keep the manual always at the unit location, easy accessible to the operating personnel.

See also the safety precautions of the engine and possible other equipment, which are separately sent along or are mentioned on the equipment or parts of the unit.

These safety precautions are general and some statements will therefore not always apply to a particular unit.

Only people that have the right skills should be allowed to operate, adjust, perform maintenance or repair on Atlas Copco equipment. It is the responsibility of management to appoint operators with the appropriate training and skill for each category of job.

Skill level 1: Operator

An operator is trained in all aspects of operating the unit with the push-buttons, and is trained to know the safety aspects.

Skill level 2: Mechanical technician

A mechanical technician is trained to operate the unit the same as the operator. In addition, the mechanical technician is also trained to perform maintenance and repair, as described in the instruction manual, and is allowed to change settings of the control and safety system. A mechanical technician does not work on live electrical components.

Skill level 3: Electrical technician

An electrical technician is trained and has the same qualifications as both the operator and the mechanical technician. In addition, the electrical technician may carry out electrical repairs within the various enclosures of the unit. This includes work on live electrical components.

Skill level 4: Specialist from the manufacturer

This is a skilled specialist sent by the manufacturer or its agent to perform complex repairs or modifications to the equipment.

In general it is recommended that not more than two people operate the unit, more operators could lead to unsafe operating conditions. Take necessary steps to keep unauthorized persons away from the unit and eliminate all possible sources of danger at the unit.

When handling, operating, overhauling and/or performing maintenance or repair on Atlas Copco equipment, the mechanics are expected to use safe engineering practices and to observe all relevant local safety requirements and ordinances. The following list is a reminder of special safety directives and precautions mainly applicable to Atlas Copco equipment.

Neglecting the safety precautions may endanger people as well as environment and machinery:

- endanger people due to electrical, mechanical or chemical influences,
- endanger the environment due to leakage of oil, solvents or other substances,
- endanger the machinery due to function failures.

All responsibility for any damage or injury resulting from neglecting these precautions or by non-observance of ordinary caution and due care required in handling, operating, maintenance or repair, also if not expressly mentioned in this instruction manual, is disclaimed by Atlas Copco.

The manufacturer does not accept any liability for any damage arising from the use of non-original parts and for modifications, additions or conversions made without the manufacturer's approval in writing.

If any statement in this manual does not comply with local legislation, the stricter of the two shall be applied.

Statements in these safety precautions should not be interpreted as suggestions, recommendations or inducements that it should be used in violation of any applicable laws or regulations.

General safety precautions

- 1 The owner is responsible for maintaining the unit in a safe operating condition. Unit parts and accessories must be replaced if missing or unsuitable for safe operation.
- 2 The supervisor, or the responsible person, shall at all times make sure that all instructions regarding machinery and equipment operation and maintenance are strictly followed and that the machines with all accessories and safety devices, as well as the consuming devices, are in good repair, free of abnormal wear or abuse, and are not tampered with.
- 3 Whenever there is an indication or any suspicion that an internal part of a machine is overheated, the machine shall be stopped but no inspection covers shall be opened before sufficient cooling time has elapsed; this to avoid the risk of spontaneous ignition of oil vapour when air is admitted.

- 4 Normal ratings (pressures, temperatures, speeds, etc.) shall be durably marked.
- 5 Operate the unit only for the intended purpose and within its rated limits (pressure, temperature, speeds, etc.).
- 6 The machinery and equipment shall be kept clean, i.e. as free as possible from oil, dust or other deposits.
- 7 To prevent an increase in working temperature, inspect and clean heat transfer surfaces (cooler fins, intercoolers, coolant jackets, etc.) regularly. See the maintenance schedule.
- 8 All regulating and safety devices shall be maintained with due care to ensure that they function properly. They may not be put out of action.
- 9 Pressure and temperature gauges shall be checked regularly with regard to their accuracy. They shall be replaced whenever outside acceptable tolerances.
- 10 Safety devices shall be tested as described in the maintenance schedule of the instruction manual to determine that they are in good operating condition.
- 11 Mind the markings and information labels on the unit.
- 12 In the event the safety labels are damaged or destroyed, they must be replaced to ensure operator safety.
- 13 Keep the work area neat. Lack of order will increase the risk of accidents.

- 14 When working on the unit, wear safety clothing. Depending on the kind of activities these are: safety glasses, ear protection, safety helmet (including visor), safety gloves, protective clothing, safety shoes. Do not wear the hair long and loose (protect long hair with a hairnet), or wear loose clothing or jewellery.
- 15 Take precautions against fire. Handle fuel, oil and anti-freeze with care because they are inflammable substances. Do not smoke or approach with naked flame when handling such substances. Keep a fire-extinguisher in the vicinity.

16a Portable generators (with earthing pin):

Earth the generator as well as the load properly.

16b Portable generators IT:

Note: This generator is built to supply a sheer alternating current IT network.
Earth the load properly.

Safety during transport and installation

To lift a unit, all loose or pivoting parts, e.g. doors and towbar, shall first be securely fastened.

Do not attach cables, chains or ropes directly to the lifting eye; apply a crane hook or lifting shackle meeting local safety regulations. Never allow sharp bends in lifting cables, chains or ropes.

Helicopter lifting is not allowed.

It is strictly forbidden to dwell or stay in the risk zone under a lifted load. Never lift the unit over people or residential areas. Lifting acceleration and retardation shall be kept within safe limits.

- 1 Before towing the unit:
 - check the towbar, the brake system and the towing eye. Also check the coupling of the towing vehicle,
 - check the towing and brake capability of the towing vehicle,
 - check that the towbar, jockey wheel or stand leg is safely locked in the raised position,
 - ascertain that the towing eye can swivel freely on the hook,
 - check that the wheels are secure and that the tyres are in good condition and inflated correctly,
 - connect the signalisation cable, check all lights and connect the pneumatic brake couplers,
 - attach the safety break-away cable or safety chain to the towing vehicle,
 - remove wheel chocks, if applied, and disengage the parking brake.

- 2 To tow a unit use a towing vehicle of ample capacity. Refer to the documentation of the towing vehicle.
- 3 If the unit is to be backed up by the towing vehicle, disengage the overrun brake mechanism (if it is not an automatic mechanism).
- 4 Never exceed the maximum towing speed of the unit (mind the local regulations).
- 5 Place the unit on level ground and apply the parking brake before disconnecting the unit from the towing vehicle. Unclip the safety break-away cable or safety chain. If the unit has no parking brake or jockey wheel, immobilize the unit by placing chocks in front of and/or behind the wheels. When the towbar can be positioned vertically, the locking device must be applied and kept in good order.
- 6 To lift heavy parts, a hoist of ample capacity, tested and approved according to local safety regulations, shall be used.
- 7 Lifting hooks, eyes, shackles, etc., shall never be bent and shall only have stress in line with their design load axis. The capacity of a lifting device diminishes when the lifting force is applied at an angle to its load axis.
- 8 For maximum safety and efficiency of the lifting apparatus all lifting members shall be applied as near to perpendicular as possible. If required, a lifting beam shall be applied between hoist and load.
- 9 Never leave a load hanging on a hoist.
- 10 A hoist has to be installed in such a way that the object will be lifted perpendicular. If that is not possible, the necessary precautions must be taken to prevent load-swinging, e.g. by using two hoists, each at approximately the same angle not exceeding 30° from the vertical.
- 11 Locate the unit away from walls. Take all precautions to ensure that hot air exhausted from the engine and driven machine cooling systems cannot be recirculated. If such hot air is taken in by the engine or driven machine cooling fan, this may cause overheating of the unit; if taken in for combustion, the engine power will be reduced.
- 12 Generators shall be stalled on an even, solid floor, in a clean location with sufficient ventilation. If the floor is not level or can vary in inclination, consult Atlas Copco.
- 13 The electrical connections shall correspond to local codes. The machines shall be earthed and protected against short circuits by fuses or circuit breakers.
- 14 Never connect the generator outlets to an installation which is also connected to a public mains.
- 15 Before connecting a load, switch off the corresponding circuit breaker, and check whether frequency, voltage, current and power factor comply with the ratings of the generator.
- 16 Before transportation of the unit, switch off all the circuit breakers.

Safety during use and operation

- 1 When the unit has to operate in a fire-hazardous environment, each engine exhaust has to be provided with a spark arrestor to trap incendiary sparks.
- 2 The exhaust contains carbon monoxide which is a lethal gas. When the unit is used in a confined space, conduct the engine exhaust to the outside atmosphere by a pipe of sufficient diameter; do this in such a way that no extra back pressure is created for the engine. If necessary, install an extractor. Observe any existing local regulations.

Make sure that the unit has sufficient air intake for operation. If necessary, install extra air intake ducts.
- 3 When operating in a dust-laden atmosphere, place the unit so that dust is not carried towards it by the wind. Operation in clean surroundings considerably extends the intervals for cleaning the air intake filters and the cores of the coolers.
- 4 Never remove a filler cap of the coolant system of a hot engine. Wait until the engine has sufficiently cooled down.
- 5 Never refill fuel while the unit is running, unless otherwise stated in the Atlas Copco Instruction Book (AIB). Keep fuel away from hot parts such as air outlet pipes or the engine exhaust. Do not smoke when fuelling. When fuelling from an automatic pump, an earthing cable should be connected to the unit to discharge static electricity. Never spill nor leave oil, fuel, coolant or cleansing agent in or around the unit.

- 6 All doors shall be shut during operation so as not to disturb the cooling air flow inside the bodywork and/or render the silencing less effective. A door should be kept open for a short period only e.g. for inspection or adjustment.
- 7 Periodically carry out maintenance works according to the maintenance schedule.
- 8 Stationary housing guards are provided on all rotating or reciprocating parts not otherwise protected and which may be hazardous to personnel. Machinery shall never be put into operation, when such guards have been removed, before the guards are securely reinstalled.
- 9 Noise, even at reasonable levels, can cause irritation and disturbance which, over a long period of time, may cause severe injuries to the nervous system of human beings.

When the sound pressure level, at any point where personnel normally has to attend, is:
 - below 70 dB(A): no action needs to be taken,
 - above 70 dB(A): noise-protective devices should be provided for people continuously being present in the room,
 - below 85 dB(A): no action needs to be taken for occasional visitors staying a limited time only,
 - above 85 dB(A): room to be classified as a noise-hazardous area and an obvious warning shall be placed permanently at each entrance to alert people entering the room, for even relatively short times, about the need to wear ear protectors,

- above 95 dB(A): the warning(s) at the entrance(s) shall be completed with the recommendation that also occasional visitors shall wear ear protectors,
 - above 105 dB(A): special ear protectors that are adequate for this noise level and the spectral composition of the noise shall be provided and a special warning to that effect shall be placed at each entrance.
- 10 Insulation or safety guards of parts the temperature of which can be in excess of 80°C (175°F) and which may be accidentally touched by personnel shall not be removed before the parts have cooled to room temperature.
 - 11 Never operate the unit in surroundings where there is a possibility of taking in flammable or toxic fumes.
 - 12 If the working process produces fumes, dust or vibration hazards, etc., take the necessary steps to eliminate the risk of personnel injury.
 - 13 When using compressed air or inert gas to clean down equipment, do so with caution and use the appropriate protection, at least safety glasses, for the operator as well as for any bystander. Do not apply compressed air or inert gas to your skin or direct an air or gas stream at people. Never use it to clean dirt from your clothes.
 - 14 When washing parts in or with a cleaning solvent, provide the required ventilation and use appropriate protection such as a breathing filter, safety glasses, rubber apron and gloves, etc.

- 15 Safety shoes should be compulsory in any workshop and if there is a risk, however small, of falling objects, wearing of a safety helmet should be included.
- 16 If there is a risk of inhaling hazardous gases, fumes or dust, the respiratory organs must be protected and depending on the nature of the hazard, so must the eyes and skin.
- 17 Remember that where there is visible dust, the finer, invisible particles will almost certainly be present too; but the fact that no dust can be seen is not a reliable indication that dangerous, invisible dust is not present in the air.
- 18 Never operate the generator in excess of its limits as indicated in the technical specifications and avoid long no-load sequences.
- 19 Never operate the generator in a humid atmosphere. Excessive moisture causes worsening of the generator insulation.
- 20 Do not open electrical cabinets, cubicles or other equipment while voltage is supplied. If such cannot be avoided, e.g. for measurements, tests or adjustments, have the action carried out by a qualified electrician only, with appropriate tools, and ascertain that the required bodily protection against electrical hazards is applied.
- 21 Never touch the power terminals during operation of the machine.
- 22 Whenever an abnormal condition arises, e.g. excessive vibration, noise, odour, etc., switch the circuit breakers to OFF and stop the engine. Correct the faulty condition before restarting.
- 23 Check the electric cables regularly. Damaged cables and insufficient tightening of connections may cause electric shocks. Whenever damaged wires or dangerous conditions are observed, switch the circuit breakers to OFF and stop the engine. Replace the damaged wires or correct the dangerous condition before restarting. Make sure that all electric connections are securely tightened.
- 24 Avoid overloading the generator. The generator is provided with circuit breakers for overload protection. When a breaker has tripped, reduce the concerned load before restarting.
- 25 If the generator is used as stand-by for the mains supply, it must not be operated without control system which automatically disconnects the generator from the mains when the mains supply is restored.
- 26 Never remove the cover of the output terminals during operation. Before connecting or disconnecting wires, switch off the load and the circuit breakers, stop the machine and make sure that the machine cannot be started inadvertently or there is any residual voltage on the power circuit.
- 27 Running the generator at low load for long periods will reduce the lifetime of the engine.

Safety during maintenance and repair

Maintenance, overhaul and repair work shall only be carried out by adequately trained personnel; if required, under supervision of someone qualified for the job.

- 1 Use only the correct tools for maintenance and repair work, and only tools which are in good condition.
- 2 Parts shall only be replaced by genuine Atlas Copco replacement parts.
- 3 All maintenance work, other than routine attention, shall only be undertaken when the unit is stopped. Steps shall be taken to prevent inadvertent starting. In addition, a warning sign bearing a legend such as “work in progress; do not start” shall be attached to the starting equipment.
On engine-driven units the battery shall be disconnected and removed or the terminals covered by insulating caps.
On electrically driven units the main switch shall be locked in open position and the fuses shall be taken out. A warning sign bearing a legend such as “work in progress; do not supply voltage” shall be attached to the fuse box or main switch.
- 4 Prior to stripping an engine or other machine or undertaking major overhaul on it, prevent all movable parts from rolling over or moving.

- 5 Make sure that no tools, loose parts or rags are left in or on the machine. Never leave rags or loose clothing near the engine air intake.
- 6 Never use flammable solvents for cleaning (fire-risk).
- 7 Take safety precautions against toxic vapours of cleaning liquids.
- 8 Never use machine parts as a climbing aid.
- 9 Observe scrupulous cleanliness during maintenance and repair. Keep away dirt, cover the parts and exposed openings with a clean cloth, paper or tape.
- 10 Never weld on or perform any operation involving heat near the fuel or oil systems. Fuel and oil tanks must be completely purged, e.g. by steam-cleaning, before carrying out such operations. Never weld on, or in any way modify, pressure vessels. Disconnect the alternator cables during arc welding on the unit.
- 11 Support the towbar and the axle(s) securely if working underneath the unit or when removing a wheel. Do not rely on jacks.
- 12 Do not remove any of, or tamper with, the sound-damping material. Keep the material free of dirt and liquids such as fuel, oil and cleansing agents. If any sound-damping material is damaged, replace it to prevent the sound pressure level from increasing.
- 13 Use only lubricating oils and greases recommended or approved by Atlas Copco or the machine manufacturer. Ascertain that the selected lubricants comply with all applicable safety regulations, especially with regard to explosion or fire-risk and the possibility of decomposition or generation of hazardous gases. Never mix synthetic with mineral oil.
- 14 Protect the engine, alternator, air intake filter, electrical and regulating components, etc., to prevent moisture ingress, e.g. when steam-cleaning.
- 15 When performing any operation involving heat, flames or sparks on a machine, the surrounding components shall first be screened with non-flammable material.
- 16 Never use a light source with open flame for inspecting the interior of a machine.
- 17 When repair has been completed, the machine shall be barred over at least one revolution for reciprocating machines, several revolutions for rotary ones to ensure that there is no mechanical interference within the machine or driver. Check the direction of rotation of electric motors when starting up the machine initially and after any alteration to the electrical connection(s) or switch gear, to check that the oil pump and the fan function properly.
- 18 Maintenance and repair work should be recorded in an operator's logbook for all machinery. Frequency and nature of repairs can reveal unsafe conditions.
- 19 When hot parts have to be handled, e.g. shrink fitting, special heat-resistant gloves shall be used and, if required, other body protection shall be applied.
- 20 When using cartridge type breathing filter equipment, ascertain that the correct type of cartridge is used and that its useful service life is not surpassed.
- 21 Make sure that oil, solvents and other substances likely to pollute the environment are properly disposed of.
- 22 Before clearing the generator for use after maintenance or overhaul, submit it to a testrun, check that the AC power performance is correct and that the control and shutdown devices function correctly.

Tool applications safety

Apply the proper tool for each job. With the knowledge of correct tool use and knowing the limitations of tools, along with some common sense, many accidents can be prevented.

Special service tools are available for specific jobs and should be used when recommended. The use of these tools will save time and prevent damage to parts.

Battery safety precautions

Batteries

When servicing batteries, always wear protecting clothing and glasses.

- 1 The electrolyte in batteries is a sulphuric acid solution which is fatal if it hits your eyes, and which can cause burns if it contacts your skin. Therefore, be careful when handling batteries, e.g. when checking the charge condition.
- 2 Install a sign prohibiting fire, open flame and smoking at the post where batteries are being charged.
- 3 When batteries are being charged, an explosive gas mixture forms in the cells and might escape through the vent holes in the plugs.
Thus an explosive atmosphere may form around the battery if ventilation is poor, and can remain in and around the battery for several hours after it has been charged. Therefore:
 - never smoke near batteries being, or having recently been, charged,
 - never break live circuits at battery terminals, because a spark usually occurs.

- 4 When connecting an auxiliary battery (AB) in parallel to the unit battery (CB) with booster cables: connect the + pole of AB to the + pole of CB, then connect the - pole of CB to the mass of the unit. Disconnect in the reverse order.

Leading particulars

General description

The QAS 60-80-100 Pd is an AC generator, built for continuous running at sites where no electricity is available or as stand-by in cases of interruption of the mains. The generator operates at 50/60 Hz, 230/240 V in line-to-neutral mode and 400/480 V in line-to-line mode. The QAS 60-80-100 Pd generator is driven by a water-cooled diesel engine, manufactured by PERKINS. An overview of the main parts is given in the diagram below.

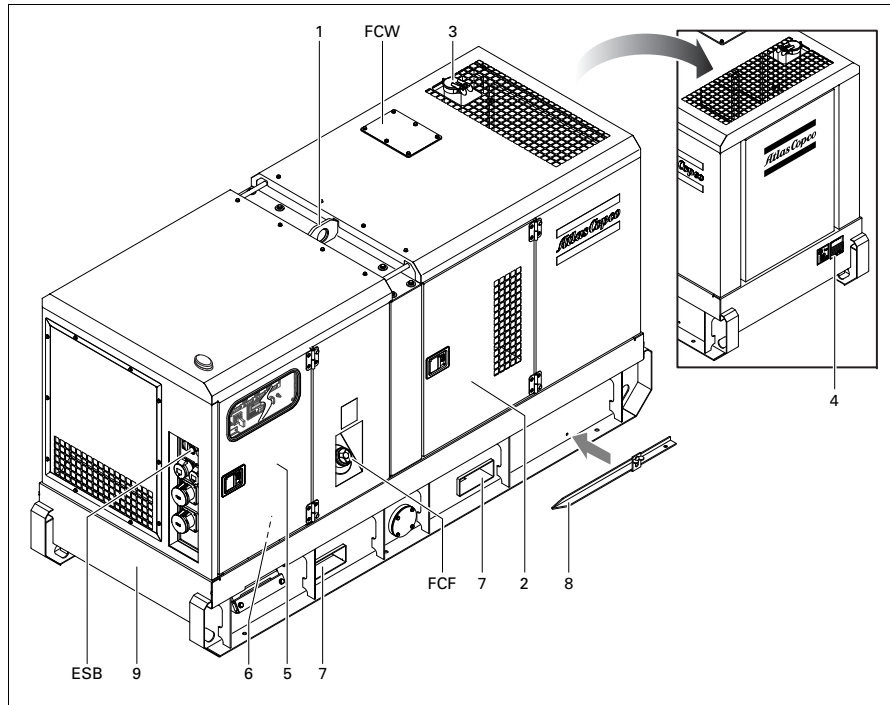

- 1 Access to lifting eye
 - 2 Side doors
 - 3 Engine exhaust outlet with rain cap
 - 4 Data plate
 - 5 Door, access to control and indicator panel
 - 6 Output terminal board
 - 7 Hole for forklift
 - 8 Earthing rod (not available in combination with an IT-relay)
 - 9 Generator frame
- ESB Emergency stop button
FCF Filler cap fuel
FCW Filler cap coolant

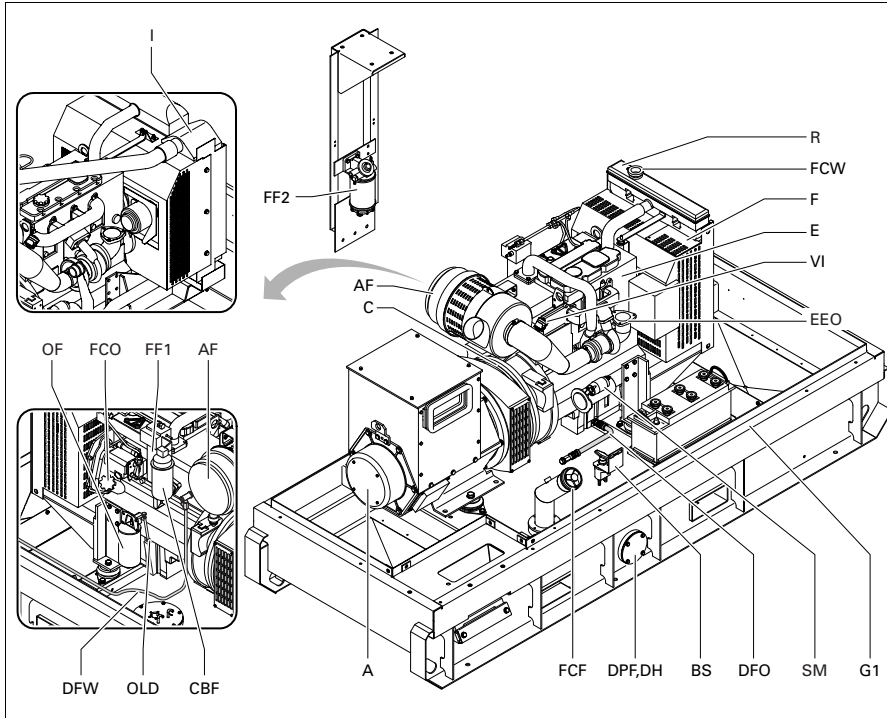

- A Alternator
- AF Air filter
- BS Battery switch
- C Coupling
- CBF Closed breather filter
- DFO Drain flexible engine oil
- DFW Drain flexible coolant
- DH Drain and access hole (in the frame)
- DPF Drain plug fuel
- E Engine
- EEO Engine exhaust outlet
- F Fan
- FCF Filler cap fuel
- FCO Filler cap engine oil
- FCW Filler cap coolant
- FF1 Fuel filter
- FF2 Fuel filter (secondary) with water separator
- G1 Battery
- I Intercooler (only for QAS 80-100 Pd)
- OF Oil filter
- OLD Engine oil level dipstick
- R Radiator
- SM Start motor
- VI Vacuum indicator

Bodywork

The alternator, the engine, the cooling system, etc. are enclosed in a sound-insulated bodywork that can be opened by means of side doors (and service plates).

The lifting beam access to lift the generator by means of crane is integrated in the bodywork and easily accessible from outside.

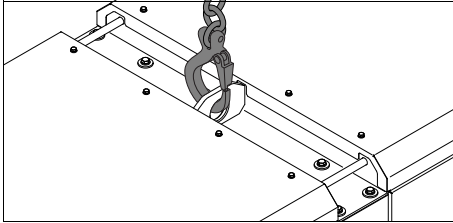

To be able to lift the generator by means of a forklift, rectangular holes are provided at the bottom of the frame.

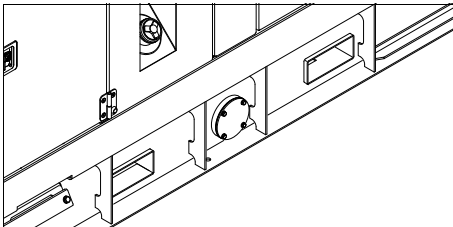

The earthing rod, connected to the generator's earth terminal is located at the bottom of the frame from outside.

Markings

A brief description of all markings provided on the generator is given hereafter.



This symbol indicates the presence of electric shock hazards. Enclosures marked with these symbols should only be opened by trained or instructed people.



Indicates that the engine exhaust is a hot and harmful gas, which is toxic in case of inhalation. Always make sure that the unit is operated outside or in a well-ventilated room.



Indicates that these parts can become very hot during operation (e.g. engine, cooler, etc.). Always make sure that these parts are cooled down before touching them.



Indicates that the guiding rods may not be used to lift the generator. Always use the lifting rod in the roof of the generator to lift it.



Indicates a lifting point of the generator.

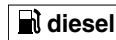

Indicates that the generator may be refuelled with diesel fuel only.

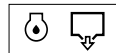

Indicates the drain for the engine oil.

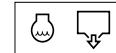

Indicates the drain for the coolant.



Indicates the drain plug for the engine fuel.



Use PAROIL E only.



Indicates the different earthing connections on the generator.



Indicates that the alternator should not be cleaned with high pressurised water.

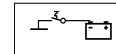

Indicates the battery switch.



Indicates that the unit may start automatically and that the instruction book has to be consulted prior to use.



Read the instruction manual before using the lifting eye.



Indicates the 3-way valve.

Atlas Copco		QAS 60 Pd, QAS 80 Pd, QAS 100 Pd	
SERVICE PACK			
Every 500h (max) 2912 4412 05			
Engine oil		PAROL L	PAROL Extra
5.1	1815 5953 00	1630 0135 00	
20.1	1815 5954 00	1630 0136 00	
209.1	1815 5955 00		
500.1	1815 5956 00		
Engine coolant		PARCOL G3	
5.1	1815 5957 00	1604 5308 00	
20.1	1815 5958 00	1604 5307 01	
210.1	1815 5959 00	1604 5309 00	

Indicates the partnumbers of the different service packs and of the engine oil. These parts can be ordered to the factory.

Drain plugs and filler caps

The drain holes for the engine oil, the coolant and the plug for the fuel, are located and labelled on the frame. The fuel drain plugs are located; one at the bottom of the frame and the other at the cubicle side of the frame.

The drain flexible for engine oil can be brought to the outside of the generator through the drain hole.



The drain hole can also be used to guide external fueltank connections. When connecting an external fueltank, use the 3-way valves. Refer to External fueltank connection (with/without quick couplings).

The filler cap for the engine coolant is accessible via an opening in the roof. The fuel filler cap is located in the side panel.

Control and indicator panel Qc1002™

General description Qc1002™ control panel

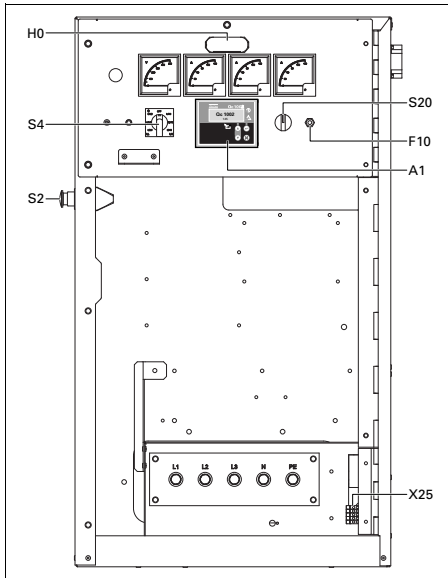

A1 Qc1002™ display

F10 Fuse

The fuse activates when the current from the battery to the engine control circuit exceeds its setting. The fuse can be reset by pushing the button.

H0 Panel light

S2 Emergency stop button

Push the button to stop the generator in case of an emergency. When the button is pressed, it must be unlocked, before the generator can be restarted. The emergency stop button can be secured in the locked position with the key, to avoid unauthorized use.

S20 ON/OFF/REMOTE switch

To start up the unit (locally or remote).

X25 Terminal strip

Qc1002™ Module

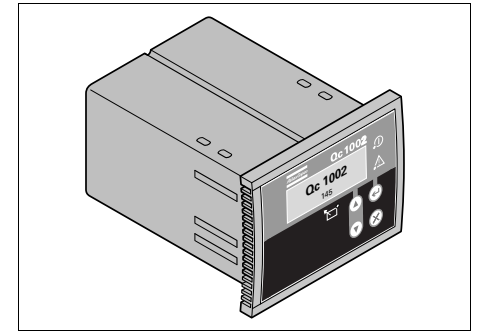

The Qc1002™ module is located inside the control panel. This control module will carry out all necessary tasks to control and protect a generator, regardless of the use of the generator.

This means that the Qc1002™ module can be used for several applications.

Pushbutton and LED functions

Following pushbuttons are used on the Qc1002™



ENTER: Is used to select and confirm changed settings in the Parameter list.



UP: Is used to scroll through the display information and to adjust parameter value upwards.



DOWN: Is used to scroll through the display information and to adjust parameter value downwards.



BACK: Is used to leave the Alarm pop-up window, to leave the Parameter list and to leave menu's without change.

Following LEDs are used on the Qc1002™

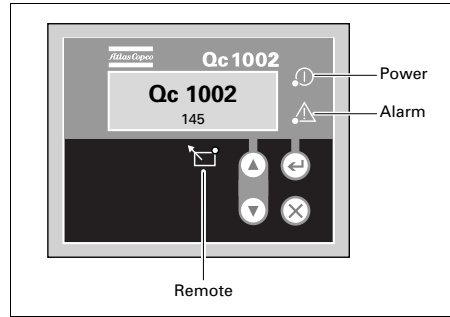

Power

Green LED indicates that the unit is powered up.

Remote

Green LED indicates that the Remote Mode is selected.

Alarm

Flashing red LED indicates that an alarm is present. A continuous red LED indicates that the alarm has been acknowledged by the user. The exact alarm is shown on the display.

Qc1002™ Menu Overview

At Qc1002™, the LCD will show following information:

- in **Normal** condition (scroll through the information using **UP** and **DOWN**):
 - Status (eg: preheat, crank, run, cooldown, extended stop time, ...)
 - Controller type & version
 - Parameter list
 - Alarm list
 - LOG list
 - Service Timer 1 & Service Timer 2
 - Battery Voltage
 - Coolant temperature
 - Oil pressure
 - Fuel level
 - Voltage - frequency - running hours
- in **Alarm** condition (scroll through the information using **UP** and **DOWN**):
 - a list of all active Alarms

It's possible to scroll through the views, using the **UP** and **DOWN** buttons. The scrolling is continuous.

If a Special status comes up, the Status Display is shown.

If an Alarm comes up, the Alarm Display is shown.

Controller type and version display



This view shows the controller type and the ASW version number.

Parameter display

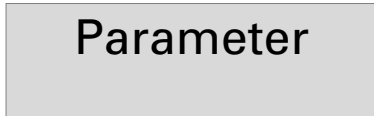

This view shows a number of Parameter settings and gives access to them.

An overview is given in "Parameter list" on page 21.

Alarm list display

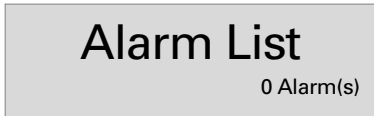

This view shows the number of active alarms and gives access to them.

An overview is given in "Alarm Display (pop-up window)" on page 23.

LOG list display



This view shows the alarm memory and gives access to it.

An overview is given in "LOG list" on page 24.

Service timer 1 & Service timer 2 display

Service 1	59h
Service 2	59h

This view shows both Service timers. The service timer indication is shown when service time has run out. It can be removed by resetting the timers or acknowledging the Service timer indication.

The service timer indications count and give an alarm when value is reached.

Resetting the Service Timers can be done through the Parameter display.

Battery Voltage display

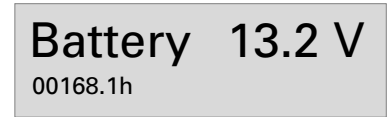

This view shows the Battery voltage and the running hours.

Coolant temperature display

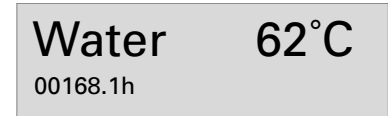

This view shows the Coolant temperature and the running hours.

See also "Parameter list" on page 21 for selection between °C and °F.

Oil pressure display



This view shows the Oil pressure and the running hours.

See also "Parameter list" on page 21 for selection between bar and psi.

Fuel level display

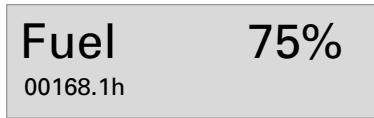

This view shows the Fuel level and the running hours.

Voltage - frequency - running hours display

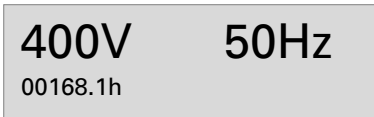

This view shows the voltage, frequency and running hours.

Qc1002™ Menu Description

Status Display (pop-up window)

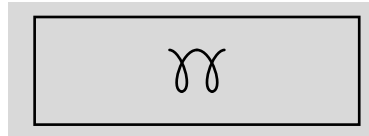

In case special statuses are entered, a pop-up window will automatically be entered for as long as the status is active.

The background screen is not updated when the status pop-up window is active.

These special statuses are:

PREHEAT

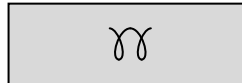

START OFF/
EXTENDED
STOP TIMER



COOLDOWN



DIAGNOSTIC

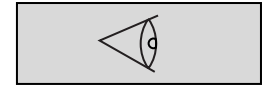

If a special status has elapsed, the active view will be entered again automatically.

If an Alarm comes up, the Alarm Display is shown.

Parameter list

The Parameter Menu's are pre-programmed!

A password will be asked for when an attempt to change a setting is about to be done (user password = 2003).

Menu's shown on the Parameter list LCD:

- Running hours adjust

This menu is used to adjust the amount of running hours. The running hours can only be raised, not lowered.

- Unit Type



Unit type 2 for QAS 60-80-100 Pd !

- Service Timer 2 reset

- Service Timer 1 reset

These menus are used to reset the service timers. When a service timer alarm occurs and is acknowledged, the service timer will be reset automatically.

- Diagnostic Menu

This menu is used to power up the engine electronics without starting the engine. When this setting is switched on, electric power will be supplied to the engine electronics after half a minute delay. The unit can not be started as long as this parameter is switched on.

- Unit Menu

This menu is used to select whether temperature and pressure should appear in °C/bar or °F/psi.

- Language selection

Icons is the default factory set language, but 6 other languages can be selected: English, French, German, Italian, Spanish and Cyrillic (Russian). All information in the Parameter List display is always in English.

- Generator Underfrequency: failclass, enable, delay, setpoint

- Generator Overfrequency: failclass, enable, delay, setpoint

- Generator Undervoltage: failclass, enable, delay, setpoint

- Generator Overvoltage: failclass, enable, delay, setpoint

It's possible to scroll between configuration menu's by using the pushbuttons UP and DOWN.

Pushing the ENTER button activates the configuration menu which is shown at the display.

This is the described menu flow for changing the unit type:

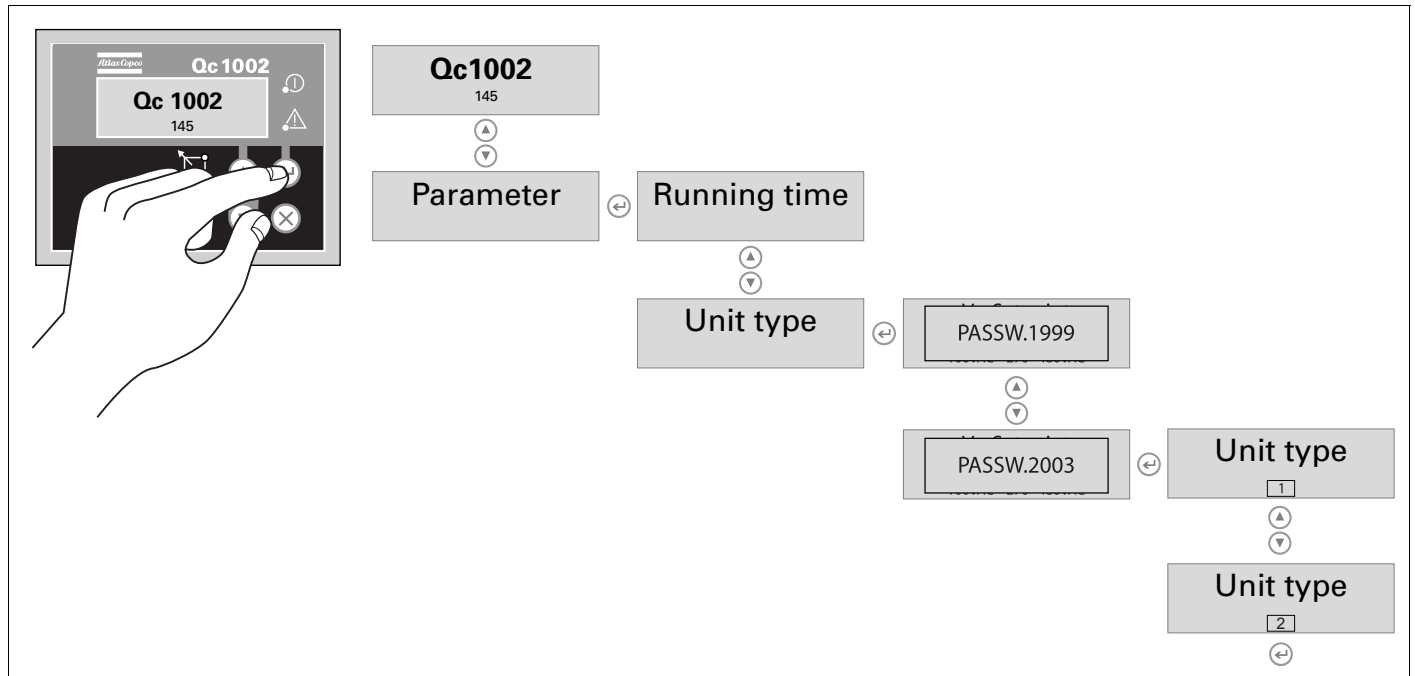

Alarm Display (pop-up window)

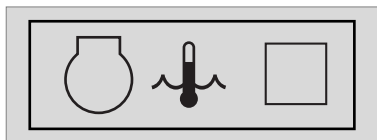

In case an Alarm occurs, a pop-up window will automatically be displayed for as long as the alarm is active, no matter which view is active. The flashing red alarm LED will light up. The alarm icons will be shown together with an acknowledgement check-box. Push the ENTER button to acknowledge the alarm. When the alarm has been acknowledged, a V-marking will appear in the check-box and the red alarm LED will light up continuously.



An alarm should always be acknowledged before solving the problem that causes the alarm.

The Alarm Display can always be left by pushing the BACK button.

If more than one alarm comes up, it's possible to scroll through the alarm messages with the UP and DOWN pushbuttons. The newest alarm will be placed at the bottom of the list (meaning that the older alarm stays at the display when a newer alarm comes up).

If one or more than one alarm is present, an arrow at the right of the display will be shown.

Following general groups of Alarms exist:

- Warning: Alarm LED lights up + Alarm pop-up appears on the display + Alarm relay is empowered (if configured)
- Trip of GB: 'Warning' actions + Generator Contactor opens
- Trip and Stop: 'Trip of GB' actions + unit stops after Cooldown
- Shutdown: 'Trip of GB' actions + unit stops immediately

List of possible alarms:

LOW OIL PRESSURE



HIGH COOLANT TEMPERATURE



CHARGING ALTERNATOR

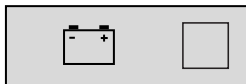

LOW FUEL LEVEL

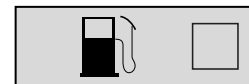

LOW COOLANT LEVEL



GENERATOR OVERVOLTAGE

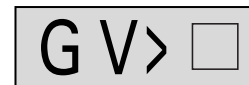

GENERATOR UNDER-VOLTAGE



GENERATOR OVER-FREQUENCY



GENERATOR UNDER-FREQUENCY



SERVICE TIMER 1



SERVICE TIMER 2

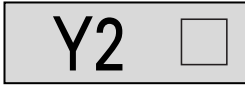

ENGINE ALARM



EMERGENCY STOP



START FAILURE



STOP FAILURE



LOG list

The unit will keep an event log of the latest 30 events.

Events are:

- shutdowns
- service timer 1/2 reset
- unit type changes

Together with each event, the running hours at the time of the event will be stored.

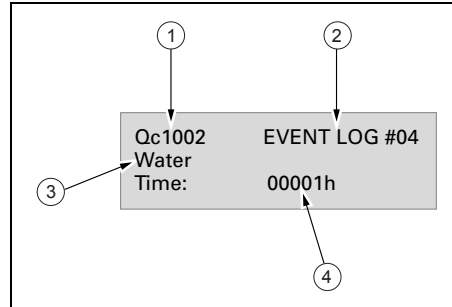

- | | |
|---|-----------------|
| 1 | Controller type |
| 2 | Event number |
| 3 | Event |
| 4 | Running hours |

Remote start operation

Installation wirings:

- X25.1 & X25.2 to be wired for the remote start switch.
- X25.3 & X25.4 to be wired for the remote contactor (open/close).

Fail classes

All the activated alarms of the Qc1002™ have their own pre-defined fail class.

All alarms are enabled according to one of these three statuses:

- disabled alarm, no supervision of alarm (OFF).
- enabled alarm, supervision of alarm all the time (ON).
- running alarm, only supervision when the machine is running (RUN).

Control and indicator panel Qc2002™

General description Qc2002™ control panel

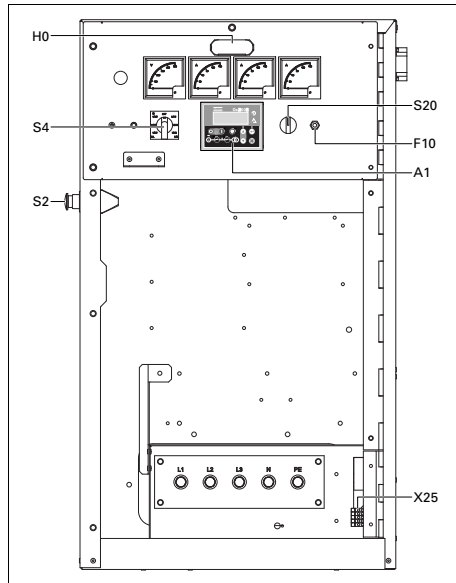

A1 Qc2002™ display

F10 Fuse

The fuse activates when the current from the battery to the engine control circuit exceeds its setting. The fuse can be reset by pushing the button.

H0 Panel light

S20 ON/OFF switch

Position O: No voltage is applied to the Qc2002™ module, the generator will not start.

Position I: Voltage is applied to the Qc2002™ module, it is possible to start up the generator.

X25 Terminal strip

Qc2002™ Module

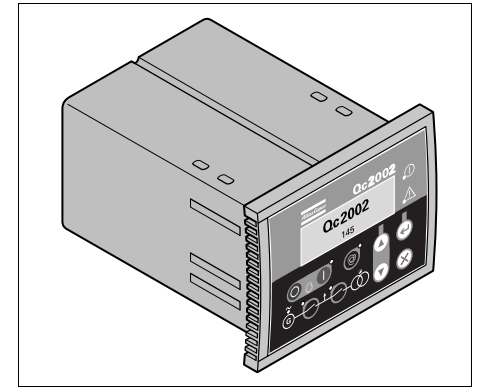

The Qc2002™ module is located inside the control panel. This control module will carry out all necessary tasks to control and protect a generator, regardless of the use of the generator.

This means that the Qc2002™ module can be used for several applications.

Pushbutton and LED functions

Following pushbuttons are used on the Qc2002™



ENTER: Is used to select and confirm changed settings in the Parameter list.



UP: Is used to scroll through the display information and to adjust parameter value upwards.



DOWN: Is used to scroll through the display information and to adjust parameter value downwards.



BACK: Is used to leave the Alarm pop-up window, to leave the Parameter list and to leave menu's without change.



AUTOMATIC: Is used to put the unit in manual or automatic operation.



START: Is used to start the unit in manual operation.



STOP: Is used to stop the unit in manual or automatic operation (without cooldown). When the unit is stopped with the STOP button in automatic operation, it will automatically go to manual operation.



MAINS CONTACTOR:

Is used to open or close the Mains contactor, if the Qc2002™ is in manual operation.



GENERATOR CONTACTOR:

Is used to open or close the Generator contactor, if the Qc2002™ is in manual operation

Following LEDs are used on the Qc2002™

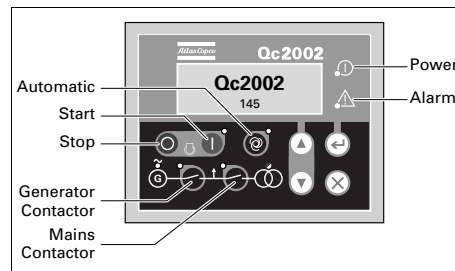

Power

Green LED indicates that the unit is powered up.

Automatic

Green LED indicates that the Qc2002™ is in automatic operation.

Start/Stop

Green LED indicates that the Qc2002™ receives running feedback (via the W/L input, via the RPM value at the Canbus, or via the AC frequency).

Generator contactor

Green LED indicates that the voltage and the frequency of the alternator are within certain limits for a certain time. It will be possible to close the Generator Contactor (both in Island and in AMF mode), if the Mains contactor is open.

Mains contactor

Green LED indicates that it is possible to close the Mains Contactor (only in AMF mode), if the Generator contactor is open.

Alarm

Flashing red LED indicates that an alarm is present. A continuous red LED indicates that the alarm has been acknowledged by the user. The exact alarm is shown on the display.

Qc2002™ Menu Overview

At Qc2002™, the LCD will show following information:

- in **Normal** condition (scroll through the information using **UP** and **DOWN**):
 - Status (eg: preheat, crank, cooldown, extended stop time, ...) (pop-up: this display is only shown when a Special status comes up)
 - Line voltages of the generator
 - Controller type & version
 - Parameter list
 - Alarm list
 - LOG list
 - Service Timer 1 & Service Timer 2
 - Battery Voltage
 - RPM (speed)
 - Coolant temperature
 - Oil pressure
 - Fuel level
 - kWh counter
 - Power factor, the frequency of the generator and the frequency of the mains
 - Line voltage, frequency and active power of the generator
 - Active, reactive and apparent power of the generator
 - Generator currents
 - Phase voltages of the mains
 - Line voltages of the mains
 - Phase voltages of the generator

- in **Alarm** condition (scroll through the information using **UP** and **DOWN**):

- a list of all active Alarms

It's possible to scroll through the views, using the **UP** and **DOWN** buttons. The scrolling is continuous.

If a Special status comes up, the Status Display is shown.

If an Alarm comes up, the Alarm Display is shown.

Line voltages generator display

G L1-L2	400V
G L2-L3	400V
G L3-L1	400V

This view shows the line voltages of the generator.

Controller type and version display

Qc2002
1.00.1

This view shows the controller type and the ASW version number.

Parameter display

Parameter

This view shows a number of Parameter settings and gives access to them.

An overview is given in “Parameter list” on page 30.

Alarm list display

Alarm List

0 Alarm(s)

This view shows the number of active alarms and gives access to them.

An overview is given in “Alarm Display (pop-up window)” on page 35.

LOG list display

LOG List

This view shows the alarm memory and gives access to it.

An overview is given in “LOG list” on page 36.

Service timer 1 & Service timer 2 display

Service 1	59h
Service 2	59h

This view shows both Service timers. The service timer indication is shown when service time has run out. It can be removed by resetting the timers or acknowledging the Service timer indication.

The service timer indications count downwards and give an alarm when the set value 0 (zero) is reached.

Resetting the Service Timers can be done through the Parameter display.

Battery voltage display

Battery 13.2 V

00168.1h

This view shows the Battery voltage and the running hours.

RPM display

RPM 0
00168.1h

This view shows the Battery voltage and the running hours.

Coolant temperature display

Water 62°C
00168.1h

This view shows the Coolant temperature and the running hours.

See also “Parameter list” on page 30 for selection between °C and °F.

Oil pressure display

Oil 3.2bar
00168.1h

This view shows the Oil pressure and the running hours.

See also “Parameter list” on page 30 for selection between bar and psi.

Fuel level display

Fuel	75%
00168.1h	

This view shows the Fuel level and the running hours.

kWh counter display

E	4860kWh
---	---------

This view shows the kWh counter.

Power factor - frequency generator - frequency mains display

PF	0.00
G f L1	50Hz
M f L1	50Hz

This view shows the PF, the frequency of the generator and the frequency of the mains (M f L1: only in AMF mode).

One line voltage - frequency - active power display

G L1-L2	400V
G f L1	50Hz
P	80kW

This view shows one line voltage, frequency and active power of the generator.

Active - reactive - apparent power display

P	80kW
Q	0kVAr
S	80kVA

This view shows the active, reactive and apparent power of the generator.

Generator current display

G I1	100A
G I2	100A
G I3	100A

This view shows the generator current.

Phase voltages mains display

M L1-N	230V
M L2-N	230V
M L3-N	230V

This view shows the phase voltages of the mains (is only shown in AMF mode).

Line voltages mains display

M L1-L2	400V
M L2-L3	400V
M L3-L1	400V

This view shows the line voltages of the mains (is only shown in AMF mode).

Phase voltages generator display

G L1-N	230V
G L2-N	230V
G L3-N	230V

This view shows the phase voltages of the generator.

Qc2002™ Menu Description

Status Display (pop-up window)

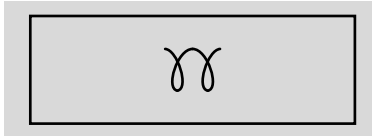

In case special statuses are entered, a pop-up window will automatically be entered for as long as the status is active.

The background screen is not updated when the status pop-up window is active.

These special statuses are:

PREHEAT



START OFF/
EXTENDED
STOP TIMER



COOLDOWN

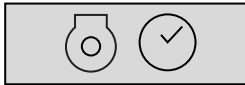

DIAGNOSTIC

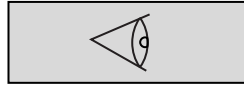

If a special status has elapsed, the active view will be entered again automatically.

If an Alarm comes up, the Alarm Display is shown.

Parameter list

The Parameter Menu's are pre-programmed !

A password will be asked for when an attempt to change a setting is about to be done (user password = 2003).

By entering the parameter list, pushbutton AUTOMATIC is disposed of its normal operations and will not perform any functionality.

It's possible to scroll between configuration menu's by using the pushbuttons UP and DOWN.

Pushing the ENTER button activates the configuration menu which is shown at the display.

Menu's shown on the Parameter list LCD:

Genset mode

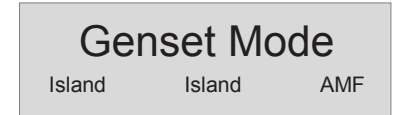

This menu is used to change the mode of the machine. In the Qc2002™ module 2 application modes can be selected:

Island operation

- This operation type is selected for local/remote start applications, without the Mains (= stand-alone).
 - Combined with Manual Operation mode = Local Start operation.
 - The sequences start/stop/close Generator Contactor/open Generator Contactor can be activated manually.
 - Combined with Automatic Operation mode = Remote Start operation.
- The remote start signal can be given with an external switch. After the generator has been started, the Generator Contactor will close automatically.
- Installation wirings for Remote Start operation: wire the RS switch between X25.9 & X25.10.

Automatic Mains Failure (AMF) operation

- This application is only possible in combination with the Auto mode. If the Manual Operation mode is selected the AMF operation will NOT function !
- When the Mains exceeds the defined voltage / frequency limits for a defined delay time, the generator will take over the load automatically.
- When the mains is restored within the defined limits for a defined time, the generator will unload before disconnecting and switching back to the Mains.
- The generator will then go into cooldown and stop.
- Installation wirings: we refer to circuit diagram 9822 0996 05/01 for the correct connections.

Horn delay

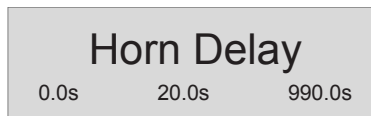

This menu is used to set the delay, how long the general alarm relay stays energized (if present). If set to 0.0s, the general alarm relay will stay energized continuously.

Running hours adjust

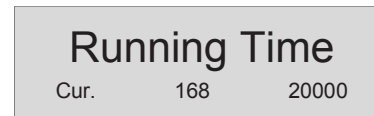

This menu is used to adjust the amount of running hours. The running hours can only be raised, not lowered.

Service timer 2 reset

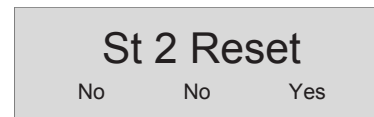

Service timer 1 reset

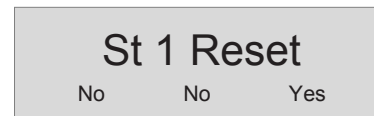

These menus are used to reset the service timers. When a service timer alarm occurs and is acknowledged, the service timer will be reset automatically.

Diagnostic menu

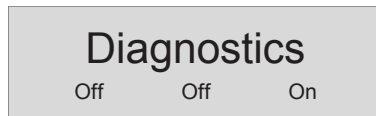

This menu is used to power up the engine electronics without starting the engine. When this setting is switched on, electric power will be supplied to the engine electronics after half a minute delay. The unit can not be started as long as this parameter is switched on.

Unit menu



This menu is used to select the units into which pressures and temperatures will be shown.

Language selection

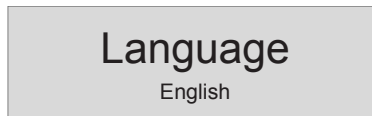

Icons is the default factory set language, but 6 other languages can be selected: English, French, German, Italian, Spanish and Cyrillic (Russian). All information in the Parameter List display is always in English.

MF high frequency

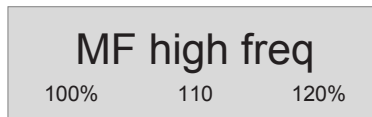

This menu is used to set the maximum limit for the mains frequency, in % of the nominal frequency (in AMF-Auto).

MF low frequency

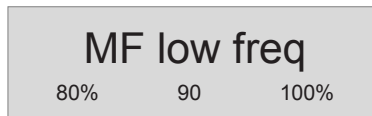

This menu is used to set the minimum limit for the mains frequency, in % of the nominal frequency (in AMF-Auto).

M frequency delay



This menu is used to set the delay, which defines how long the mains frequency has to be back within the limits before there will be switched from generator to mains again (in AMF-Auto). During this delay, the Mains LED flashes in green.

MF frequency delay



This menu is used to set the delay, which defines how long the mains frequency may be above the max limit or below the min limit before there will be switched from mains to generator (in AMF-Auto). During this delay, the Mains LED flashes in red.

MF high voltage

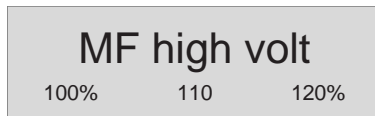

This menu is used to set the maximum limit for the mains voltage, in % of the nominal voltage (in AMF-Auto).

MF low voltage

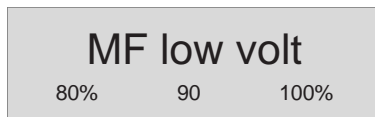

This menu is used to set the minimum limit for the mains voltage, in % of the nominal voltage (in AMF-Auto).

M voltage delay



This menu is used to set the delay, which defines how long the mains voltage has to be back within the limits before there will be switched from generator to mains again (in AMF-Auto). During this delay, the Mains LED flashes in green.

MF voltage delay



This menu is used to set the delay, which defines how long the mains voltage may be above the max limit or below the min limit before there will be switched from mains to generator (in AMF-Auto). During this delay, the Mains LED flashes in red.

Overvoltage enable

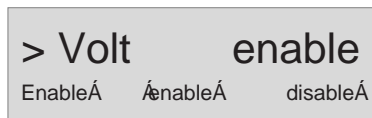

Overvoltage failclass



Overvoltage delay



Overvoltage setpoint

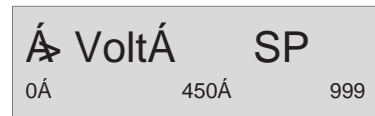

Undervoltage enable



Undervoltage failclass

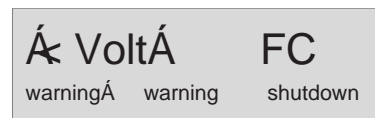

Undervoltage delay

~~Á~~ Volt~~Á~~Delay
0Á 1Á 99Á

Undervoltage setpoint

~~Á~~ VoltÁ SP
0Á 450Á 999

Overfrequency enable

> Freq enable
Enable~~Á~~ enable~~Á~~ disable

Overfrequency failclass

~~Á~~ FreqÁ FC
warningÁ warningÁ shutdown

Overfrequency delay

~~Á~~ Freq~~Á~~Delay
0Á 1Á 99Á

Overfrequency setpoint

~~Á~~ FreqÁ SP
0Á 38Á 70

Underfrequency enable

< Freq enable
Enable~~Á~~ enable~~Á~~ disable

Underfrequency failclass

~~Á~~ FreqÁ FC
warningÁ warning shutdown

Underfrequency delay

~~Á~~ Freq~~Á~~Delay
0Á 1Á 99

Underfrequency setpoint

~~Á~~ FreqÁ SP
0Á 38Á 70

Alarm Display (pop-up window)

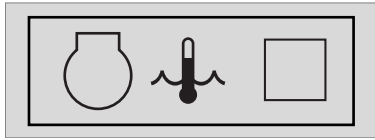

In case an Alarm occurs, a pop-up window will automatically be displayed for as long as the alarm is active, no matter which view is active. The flashing red alarm LED will light up. The alarm icons will be shown together with an acknowledgement check-box. Push the ENTER button to acknowledge the alarm. When the alarm has been acknowledged, a V-marking will appear in the check-box and the red alarm LED will light up continuously.



An alarm should always be acknowledged before solving the problem that causes the alarm.

The Alarm Display can always be left by pushing the BACK button.

If more than one alarm comes up, it's possible to scroll through the alarm messages with the UP and DOWN pushbuttons. The newest alarm will be placed at the bottom of the list (meaning that the older alarm stays at the display when a newer alarm comes up).

If one or more than one alarm is present, an arrow at the right of the display will be shown.

Following general groups of Alarms exist:

- Warning: Alarm LED lights up + Alarm pop-up appears on the display + Alarm relay is empowered (if configured)
- Trip of GB: 'Warning' actions + Generator Contactor opens
- Trip and Stop: 'Trip of GB' actions + unit stops after Cooldown
- Shutdown: 'Trip of GB' actions + unit stops immediately

List of possible alarms:

LOW OIL PRESSURE



HIGH COOLANT TEMPERATURE



CHARGING ALTERNATOR

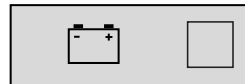

LOW FUEL LEVEL

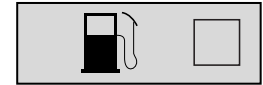

LOW COOLANT LEVEL

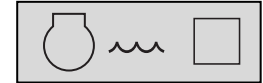

GENERATOR OVERVOLTAGE



GENERATOR UNDER-VOLTAGE



GENERATOR OVER-FREQUENCY



GENERATOR UNDER-FREQUENCY



SERVICE TIMER 1

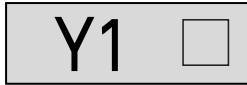

HZ/V FAILURE



SERVICE TIMER 2

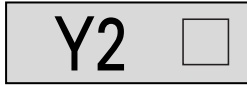

OIL LEVEL



ENGINE ALARM



OIL TEMPERATURE



EMERGENCY STOP



START FAILURE



STOP FAILURE



LOG list

The unit will keep an event log of the latest 30 events.

Events are:

- shutdowns
- service timer 1/2 reset

Together with each event, the real time of the event will be stored.

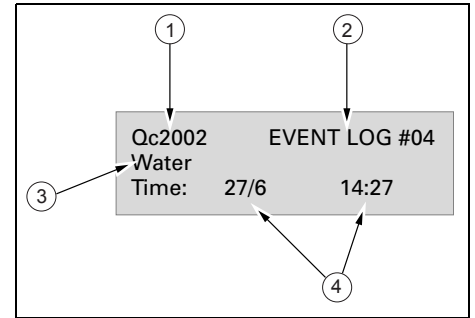

- | | |
|---|----------------------------|
| 1 | Controller type |
| 2 | Event number |
| 3 | Event |
| 4 | Date and hour of the event |

Fail classes

All the activated alarms of the Qc2002™ have their own pre-defined fail class.

All alarms are enabled according to one of these three statuses:

- disabled alarm, no supervision of alarm (OFF).
- enabled alarm, supervision of alarm all the time (ON).
- running alarm, only supervision when the machine is running (RUN).

Control and indicator panel Qc4002™

General description Qc4002™ control panel

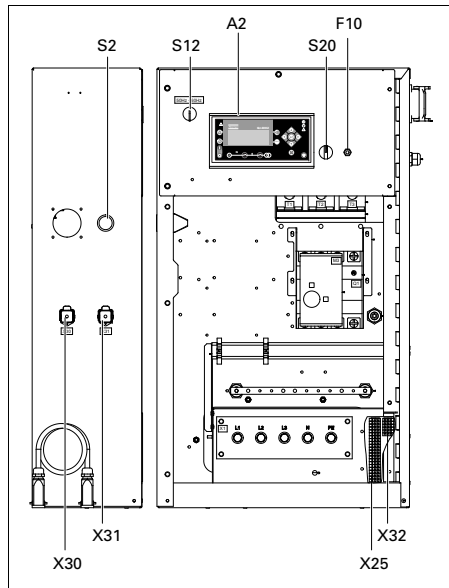

A2 Qc4002™ display

F10 Fuse

The fuse (10 A) activates when the current from the battery to the engine control circuit exceeds its setting. The fuse can be reset by pushing the button.

S2 Emergency stop button

Push the button to stop the generator in case of an emergency. When the button is pressed, it must be unlocked, before the generator can be restarted. The emergency stop button can be secured in the locked position with the key, to avoid unauthorized use.

S12 Frequency selector switch (50 Hz/ 60 Hz)

Allows to choose the frequency of the output voltage: 50 Hz or 60 Hz.



Changing the output frequency is only allowed after shutdown.

S20 ON/OFF switch

Position O: No voltage is applied to the Qc4002™ module, the generator will not start.

Position I: Voltage is applied to the Qc4002™ module, it is possible to start up the generator.

X25 Connection block

Inside the cubicle. Allows customer connections.



Refer to circuit diagram for the correct connection.

X30 Connector X30

Connector for communication with other generators with Qc4002™ when paralleling.

X31 Connector X31

Connector for communication with other generators with Qc4002™ when paralleling.

X32 Connector X32

Connector for PMS communication with other generators with Qc4002™ when paralleling.

Qc4002™ module

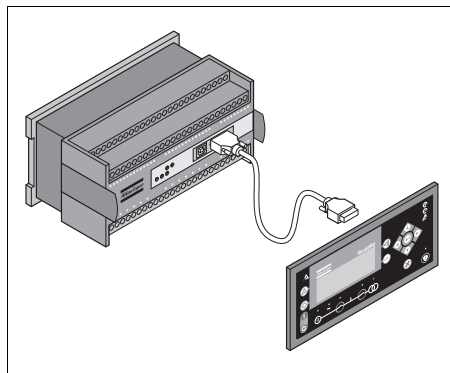

The Qc4002™ module is located inside the control panel, and communicates with a display unit, located in front of the control panel. This control module will carry out all necessary tasks to control and protect a generator, regardless of the use of the generator.

This means that the Qc4002™ module can be used for several applications.

Pushbutton and LED functions

Following pushbuttons are used on the Qc4002™



INFO: Shifts the display 3 lower lines to show the alarm list.



JUMP: Enters a specific menu number selection. All settings have a specific number attached to them. The JUMP button enables the user to select and display any setting without having to navigate through the menus.



START: Start of the gen-set if SEMI-AUTO or MANUAL is selected.



STOP: Stop of the gen-set if SEMI-AUTO or MANUAL is selected.



GB: Manual activation of close breaker and open breaker sequence if SEMI-AUTO is selected.



MB: Manual activation of close breaker and open breaker sequence if SEMI-AUTO is selected.



VIEW: Shifts the first line displaying in the setup menus.



LOG: Displays the LOG SETUP window where you can choose between the Event, Alarm and Battery logs. The logs are not deleted when the auxiliary supply is switched off.



BACK: Jumps one step backwards in the menu (to previous display or to the entry window).



MODE: Changes the menu line (line 4) in the display to mode selection.



SEL: Is used to select the underscored entry in the fourth line of the display.



UP: Increases the value of the selected set point (in the setup menu). In the daily use display, this button function is used for scrolling the View lines in V1 or the second line (in the setup menu) displaying of generator values.



DOWN: Decreases the value of the selected set point (in the setup menu). In the daily use display, this button function is used for scrolling the View lines in V1 or the second line (in the setup menu) displaying of generator values.



LEFT: Moves the cursor left for manoeuvring in the menus.



RIGHT: Moves the cursor right for manoeuvring in the menus.

Following LEDs are used on the Qc4002™

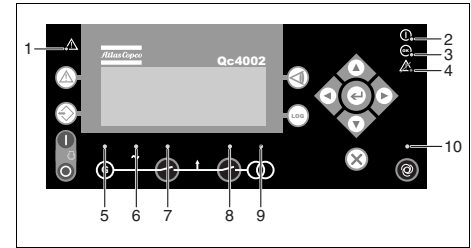

1	Alarm	LED flashing indicates that unacknowledged alarms are present. LED fixed light indicates that ALL alarms are acknowledged.
2	Power	LED indicates that the auxiliary supply is switched on.
3	Self check OK	LED indicates that the self check is OK.
4	Alarm inhibit	Please refer to Alarm inhibit in the chapter 'Additional functions'.
5	Run	LED indicates that the generator is running.
6	Generator voltage	LED green light indicates that the voltage/frequency is present and OK.

7	(GB) ON	LED green light indicates that the generator breaker is closed. LED yellow light indicates that the generator breaker has received a command to close on a black BUS, but the breaker is not yet closed due to interlocking of the GB. LED is flashing orange if the 'Spring load time' signal from the breaker is missing.
8	(MB) ON	LED indicates that the mains breaker is closed.
9	Mains voltage	LED is green, if the mains is present and OK. LED is red at a measured mains failure. LED is flashing green when the mains returns during the 'mains OK delay' time.
10	Auto	LED indicates that auto mode is selected.

The main Qc4002™ control unit includes 5 LEDs

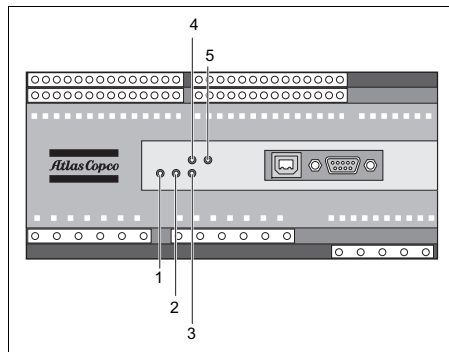

- | | | |
|---|----------------------|---|
| 1 | Power | Green LED indicates that the voltage supply is switched on. |
| 2 | Self check OK | Green LED indicates that the unit is OK. |
| 3 | Alarm inhibit | Green LED indicates that the inhibit input is ON. |
| 4 | CAN 2 | |
| 5 | CAN 1 | |

Qc4002™ menu overview

Main View

The display has 4 different lines. The information on these lines can change, depending on which view is used. There are 4 different main views possible: SETUP / V3 / V2 / V1.

Setup view

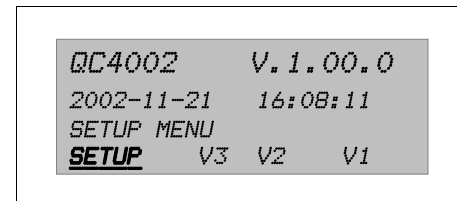

V3 view

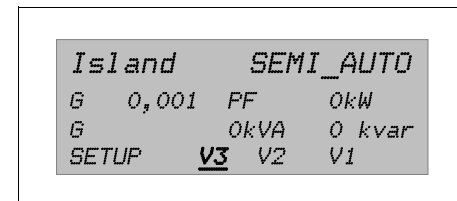

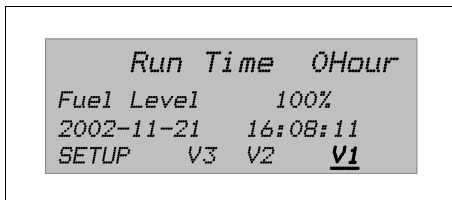
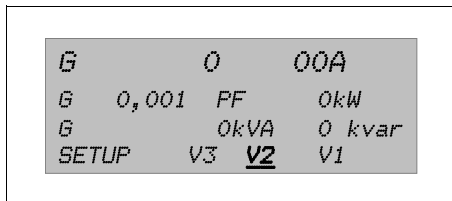

The user can scroll through these views with the scroll buttons:

- The SETUP view shows the module name, the software version, the date and the time.
- The V3 view shows the application type and the mode, and some generator measurements. During synchronisation the V3 view will show a synchronoscope in the first line.
- The V2 view shows some generator measurements.
- In the V1 view the user can scroll up and down to 15 configurable screens showing different measurements of the generator, the bus and the Mains.

SETUP menu

The control and protection parameters can be programmed according to the application. This can be done by scrolling through the setup menu to the appropriate parameter. Each parameter has a specific channel number and is listed in one of the 4 main SETUP menus:

- Protection Setup (PROT): Channels from 1000 to 1999 (steps of 10).
- Control Setup (CTRL): Channels from 2000 to 2999 (steps of 10).
- Input/Output Setup (I/O): Channels from 3000 to 5999 (steps of 10).
- System Setup (SYST): Channels from 6000 and up (steps of 10).

If you select SETUP then you get the following view:

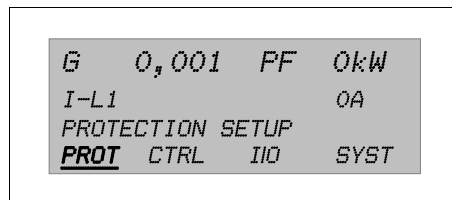

The fourth line is the entry selection for the Menu system. If the SEL button is pressed, the menu indicated with an underscore will be entered.

If PROT is selected, the following view will appear (example of parameter):

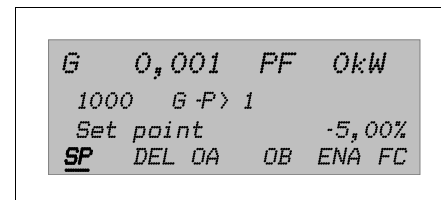

For a protective function the first entry shows the “Generator reverse power (G-P>1)” setting.

Scrolling down will give all the protection parameters:

- The first line shows some generator data.
- The second line shows the channel number and the name of the parameter.
- The third line shows the value of a set point of this parameter.
- The fourth line shows the different possible set points. In this example:

SP	SET POINT, the alarm set point is adjusted in the set point menu. The setting is a percentage of the nominal values.
DEL	DELAY, the timer setting is the time that must expire from the alarm level is reached until the alarm occurs.
OA	OUTPUT A, a relay can be activated by output A.
OB	OUTPUT B, a relay can be activated by output B.

ENA	ENABLE, the alarm can be activated or deactivated. ON means always activated, RUN means that the alarm has run status. This means it is activated when the running signal is present.
FC	FAIL CLASS, when the alarm occurs the unit will react depending on the selected fail class.

The user can scroll to these choices and select one choice with the SEL button.

After selection of SP the following view will be visible:

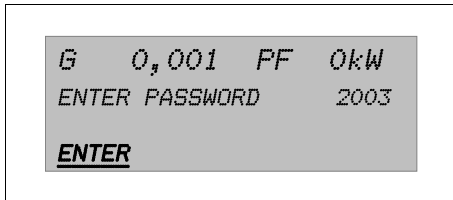

If the correct password is entered, the following view appears:

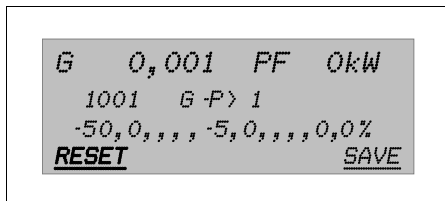

Now the user can change the SP of parameter “G-P>1”. This can be done with the scroll buttons. Then the user has to select SAVE to save the new settings. To exit the user has to press the BACK button several times, until the main view appears.

The JUMP button

Instead of navigating through the entire menu, the user can jump directly to the required parameter, if he knows the channel number of that specific parameter.

If the JUMP button is pushed the password view will appear. Not all parameters can be changed by the end-user. The required password level for each parameter is given in the set point list.

The following menus can only be reached using the JUMP button:

- 9000 Software version
- 9020 Service port
- 911X User password

Level 2 and Level 3 passwords can only be set through the Atlas Copco Utility Software PC Software.

- 9120 Service menu
- 9130 Single/Split/Three phase
- 9140 Angle comp. BB/G

Use the UP and DOWN buttons to change the settings and the SEL button to store the new setting.

This is the described menu flow:

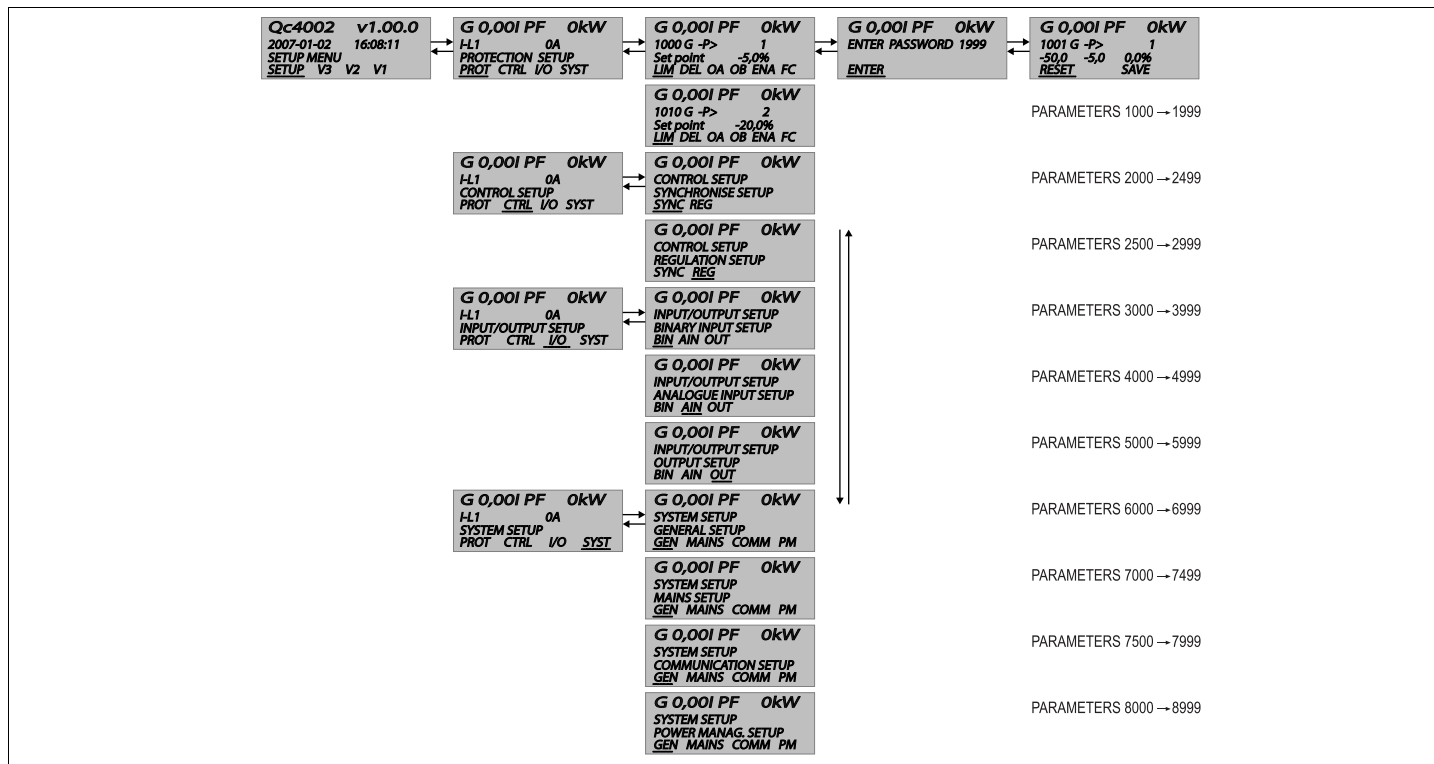

The menu flow is similar in the CONTROL SETUP, I/O SETUP and SYSTEM SETUP.



For more details on the Setup menu we refer to the Qc4002™ User Manual.

Languages

English is the default language ex-factory.

Passwords

Changing different parameters requires different password levels. Some parameters cannot be changed by the end-customer because of safety reasons.

There are 4 different password levels:

- No password
- User password (default setting 2003)
- Service password
- Master password

Once the password has been entered, the user can change all the accessible set points.

The user can change the User password (go with JUMP button to channel 9116).

Changing parameters

Consult the Qc4002™ user manual for all customer level parameters, which can be accessed using password "2003".

In order to receive the default parameters for your unit, please contact Atlas Copco Service staff.

Fail Classes

All the activated alarms of the module are configured with a fail class. The fail class defines the category of the alarm and the subsequent action.

6 different fail classes can be used:

Engine running:

- **Alarm:** Alarm Horn Relay, Alarm Display.
- **Warning:** Alarm Horn Relay, Alarm Display.
- **Trip of GB:** Alarm Horn Relay, Alarm Display, GB Trip.
- **Trip & Stop:** Alarm Horn Relay, Alarm Display, (Deload), GB Trip, Gen-Set cooling down, Gen-Set stop.
- **Shutdown:** Alarm Horn Relay, Alarm Display, GB Trip, Gen-Set stop.
- **Trip of MB:** Alarm Horn Relay, Alarm Display, MB Trip.

Engine stopped:

- **Alarm:** Block engine start.
- **Warning:** -
- **Trip of GB:** Block engine start, Block GB sequence.
- **Trip & Stop:** Block engine start, Block GB sequence.
- **Shutdown:** Block engine start, Block GB sequence.
- **Trip of MB:** Block MB sequence.

All alarms can be disabled or enabled as following:

- **OFF:** disabled alarm, inactive supervision.
- **ON:** enabled alarm.

Standard modes

The unit has four different running modes and one block mode. The required mode can be selected via the MODE pushbutton. Repeat pushing the button until the required mode appears on the display, then press SEL to select or BACK to cancel.

This screen appears when pressing the MODE pushbutton.

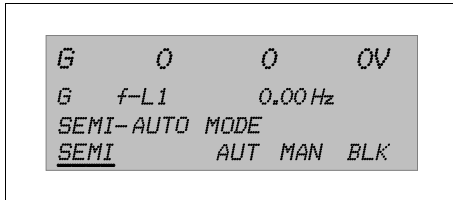

Auto mode

In this mode the Qc4002™ controls the gen-set and the circuit breakers (generator breaker GB and mains breaker MB) automatically according to the operational state.

Semi-Auto mode

In semi-auto mode the operator has to initiate all sequences. This can be done via the pushbutton functions, modbus commands or digital inputs. When started in semi-automatic mode, the gen-set will run at nominal values.

Test mode

Enables the user to test the generator on a regular basis. The generator will follow a predefined sequence of actions.

In this mode it is possible to perform the following tests:

- Simple test
- Load test
- Full test

Manual mode

When manual mode is selected, the gen-set can be controlled with digital inputs.



MAN mode cannot be selected, when AUTO mode is selected. To go from AUTO to MAN it is necessary to go to SEMI-AUTO to make MAN available.

Block mode

When the block mode is selected, the unit is locked for certain actions. This means that it cannot start the gen-set or perform any breaker operations.

To change the running mode from the display, the user will be asked for a password before the change can be made. It is not possible to select 'block mode' when running feedback is present.

The purpose of the block mode is to make sure that the gen-set does not start for instance during maintenance work. If the digital inputs are used to change the mode, then it is important to know that the input configured to block mode is a constant signal. So, when it is ON the unit is in a blocked state, and when it is OFF, it returns to the mode it was in before block mode was selected.

Diagnostics menu

This diagnostics menu can be entered via channel 6700. This menu is used for engine diagnostics situations.

If diagnostics is selected in this menu, the fuel solenoid relay output will be de-energized for 30 seconds (to make sure that the unit is completely stopped), and then gets energized again. Then engine diagnostics can take place.

To leave this status, disable diagnostics in channel 6700, or press stop, or start the machine (not during the first 30 s).



It's only possible to start the generator when Normal is selected.

Standard applications

In the Qc4002™ module 9 application types can be selected. A combination of each application type with the running mode results in a specific application.

Gen-set mode	Running mode				
	Auto	Semi	Test	Man	Block
Automatic Mains Failure (no back sync.)	X	(X)	X	X	X
Automatic Mains Failure (with back sync.)	X	(X)	X	X	X
Island operation	X	X		X	X
Fixed power/base load	X	X	X	X	X
Peak shaving	X	X	X	X	X
Load take over	X	X	X	X	X
Mains power export	X	X	X	X	X
Multiple gen-sets, load sharing	X	X		X	X
Multiple gen-sets, power management	X	(X)	X	X	X

Depending on the application the user has to connect extra wirings to terminal blocks X25. These terminal blocks can be found inside the control box on a DIN-rail. We refer to the circuit diagram 9822 0996 08/01 for the correct connections.

Island operation

This application is possible in combination with SEMI-AUTO mode or AUTO mode. The internal real time clock timer can only be used in AUTO

This operation type is selected for installations with one or more generators, but always without the Mains (= stand-alone). In practice up to 16 generators can be installed in parallel.

Installation wirings

- Terminals X25.10/X25.11 have to be linked. The module always needs a feedback signal from the Mains Breaker MB. In Island mode there is no MB in the system. In this case the MB opened signal is simulated with this link.
- The busbar sensing lines have to be wired to the corresponding control module inputs. Place bridge between:
 - X25.33 (L1) => X25.3
 - X25.34 (L2) => X25.4
 - X25.35 (L3) => X25.5
 - X25.36 (N) => X25.6(The busbar = power cables between GB and load)
- For Remote Start operation:
 - wire the RS switch between X25.9 & X25.10.
- For Paralleling applications with other generators:
 - See “Paralleling” to set up generator for paralleling.

Automatic Mains Failure (AMF) operation

This application is only possible in combination with the AUTO mode. If the SEMI-AUTO mode is selected the AMF operation will NOT function!

The unit automatically starts the gen-set and switches to generator supply at a mains failure after an adjustable delay time.

– AMF no back synchronisation:

When the mains returns, the unit will switch back to mains supply and cool down and stop the gen-set. The switching back to mains supply is done without back synchronisation when the adjusted ‘Mains OK delay’ has expired.

– AMF with back synchronisation:

When the mains returns, the unit will synchronise the mains breaker to the busbar when the ‘Mains OK delay’ has expired. Then the gen-set cools down and stops.

Installation wirings

- The link between X25.10/X25.11 has to be removed.
- Mains breaker feedback lines have to be wired to X25.10/X25.11/X25.12.

- Mains breaker control lines have to be wired to X25.13/X25.14/X25.15/X25.16. These terminals are voltage free contacts. The power for the MB has to be supplied by the customer (24 Vdc/ 230 Vac) (max. contact rating K11, K12 = 250 V/ 16 A).
- The Mains sensing lines L1/L2/L3/N have to be wired to terminals X25.3/X25.4/X25.5/X25.6.
- Make sure the connections between X25.33 & X25.3; X25.34 & X25.4; X25.35 & X25.5; X25.36 & X25.6 are removed.
- If back synchronisation is enabled, all settings for paralleling set up (see “Paralleling”) must be verified also.

Peak Shaving (PS) operation

This application is normally used in combination with the AUTO mode. Installation with the Mains.

The generator will start up when the mains imported power (measured through an optional Power Transducer = PT) exceeds a defined level. The generator will synchronise with the bus, and will take load until the defined allowable mains imported power level is reached.

When the mains imported power decreases below the defined mains imported power level for a defined time, the generator will unload and disconnect from the bus. Then the generator will go into cool down.

Installation wirings

- The link between X25.10/X25.11 has to be removed.
- Mains breaker feedback lines have to be wired to X25.10/X25.11/X25.12.
- Mains breaker control lines have to be wired to X25.13/X25.14/X25.15/X25.16. These terminals are voltage free contacts. The power for the MB has to be supplied by the customer (24 Vdc/ 230 Vac) (max. contact rating K11, K12 = 250 V /16 A).
- The Mains sensing lines L1/L2/L3/N have to be wired to terminals X25.3/X25.4/X25.5/X25.6.
- Make sure the connections between X25.33 & X25.3; X25.34 & X25.4; X25.35 & X25.5; X25.36 & X25.6 are removed.
- Power Transducer lines have to be wired to X25.21 (input) and X25.22 (GND).
- Verify all settings for paralleling set up (see “Paralleling”).

Fixed Power (FP) operation

This application is possible in combination with SEMI-AUTO mode or AUTO mode. Normally it is used in combination with SEMI-AUTO mode in installations with the Mains. The internal real time clock timer can only be used in AUTO mode.

The generator will deliver a defined fixed power to the load or to the Mains.

Installation wirings

- The link between X25.10/X25.11 has to be removed.
- Mains breaker feedback lines have to be wired to X25.10/X25.11/X25.12.
- Mains breaker control lines have to be wired to X25.13/X25.14/X25.15/X25.16. These terminals are voltage free contacts. The power for the MB has to be supplied by the customer (24 Vdc/ 230 Vac) (max. contact rating K11, K12 = 250 V/ 16 A).
- The Mains sensing lines L1/L2/L3/N have to be wired to terminals X25.3/X25.4/X25.5/X25.6.
- Make sure the connections between X25.33 & X25.3; X25.34 & X25.4; X25.35 & X25.5; X25.36 & X25.6 are removed.
- Verify all settings for paralleling set up (see “Paralleling”).

Load Take Over (LTO) operation

This application is normally used in combination with SEMI-AUTO mode or AUTO mode in installations with the Mains.

The purpose of the load take over mode is to transfer the load imported from the mains to the gen-set for operation on generator supply only.

The generator will start-up, synchronise and take over the load from the Mains gradually, before opening the Mains Breaker. To know if the load is completely taken over from the mains, an optional Power Transducer is necessary.

Installation wirings

- The link between X25.10 & X25.11 has to be removed.
- Mains breaker feedback lines have to be wired to X25.10/X25.11/X25.12.
- Mains breaker control lines have to be wired to X25.13/X25.14/X25.15/X25.16. These terminals are voltage free contacts. The power for the MB has to be supplied by the customer (24 Vdc/ 230 Vac) (max. contact rating K11, K12 = 250 V/ 16 A).
- The Mains sensing lines L1/L2/L3/N have to be wired to terminals X25.3/X25.4/X25.5/X25.6.

- Make sure the connections between X25.33 & X25.3; X25.34 & X25.4; X25.35 & X25.5; X25.36 & X25.6 are removed.
- Power Transducer lines have to be wired to X25.21 (input) and X25.22 (GND).
- Verify all settings for paralleling set up (see “Paralleling”).

Mains power export (MPE) operation

This application is possible in combination with SEMI-AUTO mode or AUTO mode. The internal real time clock timer can only be used in AUTO mode. Installation is with the Mains.

The mains power export mode can be used to maintain a constant level of power through the mains breaker. The power can be exported to the mains or imported from the mains, but always at a constant level.

Installation wirings

- The link between X25.10 & X25.11 has to be removed.
- Mains breaker feedback lines have to be wired to X25.10/X25.11/X25.12.

- Mains breaker control lines have to be wired to X25.13/X25.14/X25.15/X25.16. These terminals are voltage free contacts. The power for the MB has to be supplied by the customer (24 Vdc/ 230 Vac) (max. contact rating K11, K12 = 250 V/ 16 A).
- The Mains sensing lines L1/L2/L3/N have to be wired to terminals X25.3/X25.4/X25.5/X25.6.
- Make sure the connections between X25.33 & X25.3; X25.34 & X25.4; X25.35 & X25.5; X25.36 & X25.6 are removed.
- Power Transducer lines have to be wired to X25.21 (input) and X25.22 (GND).
- Verify all settings for paralleling set up (see "Paralleling").

Multiple gen-sets with load sharing

In this application the units are enabled to share the active and reactive load equally in percentage of the nominal power. The load sharing is active when each gen-set is running in island mode and the generator breaker is closed.

Multiple gen-sets with power management (PMS)

PMS (= Power Management System) is a system that will automatically start & stop generators based on the actual load dependency. This will be done through a PMS communication between the different units connected.

PMS applications are always in combination with AUTO mode. If the SEMI-AUTO mode is selected, the PMS operation will NOT function! The Qc4002™ controllers from the gensets need to be programmed as PMS in AUTO mode. When a Qc Mains controller is installed this needs to be programmed in the application that is required (AMF, LTO, FP, MPE) and AUTO mode.



By programming the parameters in AUTO mode, the generator can start up immediately. It is recommended to place the generator in SEMI-AUTO mode while programming all the PMS parameters !

Installations are possible with stand-alone generators or with the Mains (extra Qc4002™ Mains is then needed). A number of Qc4002™ units are being used in the power management application, i.e. one for each mains breaker (Qc4002™ mains controller), if installed, and one for each generator (Qc4002™ genset controller). All units communicate by means of an internal CANbus connection.

In an application with PMS it is important to program correctly the Start & Stop signals between the different generators because of the following reasons:

- The maximum load step needs to be programmed in the Qc4002™ controllers. This never may exceed the power reserve of the running generators. Otherwise the gensets will go in overload with a sudden max. load increase before the next generator is started up and connected to the busbar.
- To prevent the gensets to run in a start - stop loop.

The start signal is the value of the maximum required load step.

The stop signal is the value when the generator should be stopped automatically.

Example: Installation with 3 gensets

G1 = 300 kW; G2 = 200 kW; G3 = 200 kW.

- Start signal is set at 90 kW (maximum load step < 90 kW).

Start signal if:

Total Power needed > (total available power of running gensets - set point start signal).

- Only G1 is running; at 210 kW load (300 kW - 90 kW) => G2 will be started.
- G1 & G2 are running; at 410 kW load (200 kW + 300 kW - 90 kW) => G3 will be started.
- Stop signal is set at 100 kW and priority is set as (high) G1 > G2 > G3 (low).

Stop signal if:

Total Power needed < (Total available power of running gensets - Power of generator with lowest priority - set point stop signal).

- G1 & G2 & G3 are running; at 400 kW (700 kW - 200 kW - 100 kW) => G3 will be stopped.
- G1 & G2 are running; at 200 kW (500 kW - 200 kW - 100 kW) => G2 will be stopped.

The priority on starting & stopping the generators can be chosen on priority settings or on the amount of running hours. In manual mode the start & stop sequence is determined by the chosen priority between the generators. The generator with the lowest priority will start as the latest genset and will stop as first. If running hours are chosen as priority the start & stop sequence will be defined based on the actual running hours of the different generators. The lowest running hours will get the highest priority.



When paralleling generators with PMS, it is no longer necessary to use the analogue load sharing lines. This will be done through the PMS communication lines. Use a screened CAN communication cable with a maximum total distance of 200 meters. Do not connect the cable screen to the ground! Use a 120 Ohm resistor at both end controllers of the PMS.



For more information on this option, see User Manual Qc4002™.

Paralleling

Prior to starting parallel operation of two generators, following connections need to be made:

- Connect the communication cable between the generators (sockets X30 & X31).

Each dedicated generator or SAPE has two of these connections, to enable paralleling more than two generators.

- Connect the load with the generator.

Go via the site distribution panel (to be installed by the customer) to connect the generator(s) and/or the SAPE unit(s) with the load. Always connect generator with the load, and never directly with second generator.

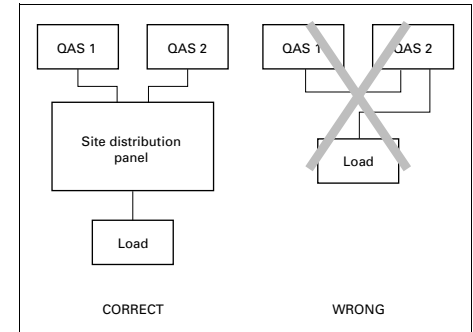

When paralleling, make sure to disable the Earth leakage relay by putting switch S13 into off position.

Overview of applications

Installations with only 1 generator

Application type	Mode	Comments
Island operation	SEMI-AUTO mode	= Local start
	AUTO mode	= Remote start
AMF operation	(SEMI-AUTO mode)	AMF operation will not function properly !
	AUTO mode	= Emergency start @ Mains Failure
Peak shaving	SEMI-AUTO mode	Only with Power Transducer (*)
	AUTO mode	Only with Power Transducer (*)
Fixed Power	SEMI-AUTO mode	
	AUTO mode	
Load Take Over	SEMI-AUTO mode	Only with Power Transducer (*)
	AUTO mode	Only with Power Transducer (*)
Mains Power Export	SEMI-AUTO mode	Only with Power Transducer (*)
	AUTO mode	Only with Power Transducer (*)

(*) A Power Transducer is a device that measures the actual power of the mains and which translates this into a 4...20 mA signal towards the Qc4002™ module. For details, please contact Atlas Copco.

Installations with more generators

Application type	Mode	Comments
Island operation	SEMI-AUTO mode	= Manual paralleling between generators
	AUTO mode	= Remote paralleling between generators
AMF operation	(SEMI-AUTO mode)	AMF operation will not function properly !
	AUTO mode	PMS + Qc4002™ Mains module (**)
Peak shaving	SEMI-AUTO mode	PMS + Qc4002™ Mains module (**)
	AUTO mode	PMS + Qc4002™ Mains module (**)
Fixed Power	SEMI-AUTO mode	PMS + Qc4002™ Mains module (**)
	AUTO mode	PMS + Qc4002™ Mains module (**)
Load Take Over	SEMI-AUTO mode	PMS + Qc4002™ Mains module (**)
	AUTO mode	PMS + Qc4002™ Mains module (**)
Main Power Export	SEMI-AUTO mode	PMS + Qc4002™ Mains module (**)
	AUTO mode	PMS + Qc4002™ Mains module (**)
Power Management System	(SEMI-AUTO mode)	PMS + Qc4002™ Mains module (**)
	AUTO mode	PMS + Qc4002™ Mains module (**)

(**) The power management system (PMS) allows communication between the Qc4002™ modules over CAN-bus. It has a fully intelligent system, which will start/load/stop the generator according to the actual load and to the status of each generator. The installation can contain up to 16 Qc4002™ modules. If the Mains is included in the installation, then an extra Qc4002™ module is required. The installation can be monitored and controlled via the PMS Software Package. For details on this application, please contact Atlas Copco.



1. Each installation has to be prepared and reviewed very carefully before start-up. Wrong or incomplete wirings can damage the installation brutally !
2. Each application requires a specific combination of the following parameters:
 - Auto / Semi-auto / Test / Manual / Block mode.
 - Island / AMF / PS / FP / LTO / MPE / PMS application type (in AUTO mode PS / FP / LTO can be combined with AMF).
 - Back synchronising enabled/disabled (parameter channel 7080).

Wrong parameter settings can damage the installation brutally !

3. To be able to start up in cold conditions, parameter 6181 (Start prepare) can be changed to a higher value to have some preheating. Do not put this value above 60 seconds to avoid any possible damage.
4. For more information on the Qc4002™ module and its applications, we refer to the Qc4002™ User manual. If you need more assistance, please contact Atlas Copco.

Output terminal board

The output terminal board is situated below the control and indicator panel.

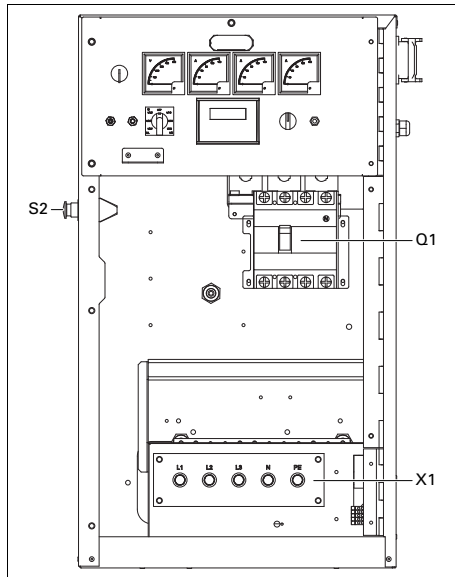

S2Emergency stop button

Push the button to stop the generator in case of an emergency. When the button is pressed, it must be unlocked, by turning it anti-clockwise, before the generator can be restarted. The emergency stop button can be secured in the locked position with the key, to avoid unauthorized use.

Q1Main circuit breaker

Interrupts the power supply to X1 when a short-circuit occurs at the load side, or when the earth leak detector (30 mA) or the overcurrent protection (QAS 60: 100 A, QAS 80: 125 A, QAS 100: 144 A) is activated or when the shunt trip is energized. It must be reset manually after eliminating the problem.

X1Main power supply (400 V AC)

Terminals L1, L2, L3, N (= neutral) and PE (= earthing), hidden behind the control panel door and behind a small transparent door.

Spillage free

A Spillage free skid with forklift slots allows the customer to transport the generator easily with a forklift.

It avoids accidental spilling of engine fluids.

Operating instructions



In your own interest, always strictly observe all relevant safety instructions.

Do not operate the generator in excess of the limitations mentioned in the Technical Specifications.

Local rules concerning the setting up of low voltage power installations (below 1000 V) must be respected when connecting site distribution panels, switch gear or loads to the generator.

At each start-up and at any time a new load is connected, the earthing of the generator must be verified. Earthing must be done either by the earthing rod or, if available, by an existing, suitable earthing installation. The protective system against excessive contact voltage is not effective unless a suitable earthing is made.

The generator is wired for a TN-system to IEC 364-3, i.e. one point in the power source directly earthed - in this case the neutral. The exposed conductive parts of the electric installation must be directly connected to the functional earth.

If operating the generator in another power system, e.g. an IT-system, other protective devices required for these types must be installed. In any case only a qualified electrician is authorized to remove the connection between the neutral (N) and earth terminals in the terminal box of the alternator.

Installation

- Place the generator on a horizontal, even and solid floor.
- The generator should be kept with the doors closed, in order to avoid the ingress of water and dust. Dust ingress reduces the lifetime of filters and may reduce your generator's performance.
- Check that the engine exhaust is not directed towards people. If the generator is operated indoors, install an exhaust pipe of sufficient diameter to duct the engine exhaust towards the outside. Check for sufficient ventilation so that the cooling air is not recirculated. If necessary, consult Atlas Copco.
- Leave enough space for operation, inspection and maintenance (at least 1 meter at each side).
- Check that the inner earthing system is in compliance with the local legislation.
- Use coolant for the engine cooling system. Refer to the Engine instruction book for the proper coolant mixture.

- Check the tightness of the bolts and nuts.
- Install the earthing rod as near as possible to the generator and make sure not to have a contact voltage higher than 25 V.
- Check that the cable end of the earthing rod is connected to the earth terminal.

Connecting the generator

Precautions for non-linear and sensitive loads



Non-linear loads draw currents with high contents in harmonics, causing distortion in the wave form of the voltage generated by the alternator.

The most common non-linear, 3-phase loads are thyristor/rectifier-controlled loads, such as convertors supplying voltage to variable speed motors, uninterruptable power supplies and Telecom supplies. Gas-discharge lighting arranged in single-phase circuits generate high 3rd harmonics and risk for excessive neutral current.

Loads most sensitive to voltage distortion include incandescent lamps, discharge lamps, computers, X-ray equipment, audio amplifiers and elevators.

Consult Atlas Copco for measures against the adverse influence of non-linear loads.

Quality, minimum section and maximum length of cables

The cable connected to the terminal board of the generator must be selected in accordance with local legislation. The type of cable, its rated voltage and current carrying capacity are determined by installation conditions, stress and ambient temperature. For flexible wiring, rubber-sheathed, flexible core conductors of the type H07 RN-F (Cenelec HD.22) or better must be used.

The following table indicates the maximum allowable 3-phase currents (in A), in an ambient temperature of 40°C, for cable types (multiple and single core PVC insulated conductors and H07 RN-F multiple core conductors) and wire sections as listed, in accordance with VDE 0298 installation method C3. Local regulations remain applicable if they are stricter than those proposed below.

Wire section (mm ²)	Max. current (A)		
	Multiple core	Single core	H07 RN-F
2.5	22	25	21
4	30	33	28
6	38	42	36
10	53	57	50
16	71	76	67
25	94	101	88
35	114	123	110
50	138	155	138
70	176	191	170
95	212	228	205

The lowest acceptable wire section and the corresponding maximum cable or conductor length for multiple core cable or H07 RN-F, at rated current (20 A), for a voltage drop e lower than 5% and at a power factor of 0.80, are respectively 2.5 mm² and 144 m. In case electric motors must be started, oversizing the cable is advisable.

The voltage drop across a cable can be determined as follows:

$$e = \frac{\sqrt{3} \cdot I \cdot L \cdot (R \cdot \cos \varphi + X \cdot \sin \varphi)}{1000}$$

e = Voltage drop (V)

I = Rated current (A)

L = Length of conductors (m)

R = Resistance (Ω /km to VDE 0102)

X = Reactance (Ω /km to VDE 0102)

Connecting the load

Site distribution panel

If outlet sockets are provided, they must be mounted on a site distribution panel supplied from the terminal board of the generator and in compliance with local regulations for power installations on building sites.

Protection



For safety reasons, it is necessary to provide an isolating switch or circuit breaker in each load circuit. Local legislation may impose the use of isolating devices which can be locked.

- Check whether frequency, voltage and current comply with the ratings of the generator.
- Provide for the load cable, without excessive length, and lay it out in a safe way without forming coils.
- Open the door of the control and indicator panel and the transparent door in front of the terminal board X1.
- Provide the wire ends with cable lugs suited for the cable terminals.
- Loosen the cable clamp and push the wire ends of the load cable through the orifice and clamp.
- Connect the wires to the proper terminals (L1, L2, L3, N and PE) of X1 and tighten the bolts securely.
- Tighten the cable clamp.
- Close the transparent door in front of X1.

Before starting

- With the generator standing level, check the engine oil level and top up if necessary. The oil level must be near to, but not exceed the high mark on the engine oil level dipstick.
- Check the coolant level in the expansion tank of the engine cooling system. The coolant level must be near to the FULL mark. Add coolant if necessary.
- Drain any coolant and sediment from the fuel pre-filter. Check the fuel level and top up if necessary. It is recommended to fill the tank after the day's operation to prevent coolant/damp in a nearly empty tank from condensing.
- Check the vacuum indicator of the air filter. If the red part shows completely, replace the filter element.
- Press the vacuator valve of the air filter to remove dust.
- Check the generator for leakage, tightness of wire terminals, etc. Correct if necessary.
- Check that fuse F10 has not tripped and that the emergency stop is in the OUT position.
- Check that the load is switched off.
- Check that circuit breaker Q1 is switched off.
- Check that the earth fault protection (N13) has not tripped (reset if necessary).

Operating Qc1002™

Starting Qc1002™

To start up the unit locally, proceed as follows:

- Switch on the battery switch, if applicable.
- Switch off circuit breaker Q1. This is not necessary when a plant contactor is installed between Q1 and the load.
- Put the starter switch S20 in position I (ON). The unit starts a preheating cycle which takes 12 seconds.
- After the preheating period, the unit will start. The starting attempt will take maximum 12 seconds.
- Switch on circuit breaker Q1.

To start up the unit from a remote location, proceed as follows:

- Put the starter switch S20 in position  .
- Switch on circuit breaker Q1.
- Put the remote start/stop switch in position start. The unit starts a preheating cycle which takes 12 seconds.
- After the preheating period, the unit will start. The starting attempt will take maximum 12 seconds.
- An external contactor can be connected and controlled by the Qc1002™.

During operation Qc1002™

Following points should be carried out regularly:

- Check the engine gauges and the lamps for normal readings.



Avoid to let the engine run out of fuel. If it happened, priming will speed up the starting.

- Check for leakage of oil, fuel or coolant.
- Avoid long low-load periods (< 30%). In this case, an output drop and higher oil consumption of the engine could occur.
- Check, by means of the generator gauges, that the voltage between the phases is identical and that the rated current in the third phase (L3) is not exceeded.
- When single-phase loads are connected to the generator output terminals, keep all loads well-balanced.

If circuit breakers are activated during operation, switch off the load and stop the generator. Check and, if necessary, decrease the load.



The generator's doors may only remain opened for short periods during operation, to carry out checks for example.

Stopping Qc1002™

To stop the unit locally, proceed as follows:

- Switch off the load.
- Switch off circuit breaker Q1.
- Let the engine run for about 5 minutes.
- Stop the engine by putting the starter switch S20 in position O.
- Lock the side doors and the door of the indicators and control panel to avoid unauthorized access.

To stop the unit when the starter switch is in position  , proceed as follows:

- Switch off the load.
- Stop the engine by putting the remote start/stop switch in position stop or by putting the starter switch S20 in position O.
- Cooldown period default 15 sec.
- Lock the side doors and the door of the indicators and control panel to avoid unauthorized access.

Operating Qc2002™

Starting Qc2002™

To start up the unit locally, proceed as follows:

- Switch on the battery switch.
- Switch off circuit breaker Q1. This is not necessary when a plant contactor is installed between Q1 and the load.
- Put the starter switch S20 in position I (ON). Voltage is applied to the Qc2002™ module.
- The unit can be started manually by pressing the START button on the Qc2002™ module.
- The unit starts a preheating cycle which takes 12 seconds.
- After the preheating period, the unit will start. The starting attempt will take maximum 12 seconds.
- Switch on circuit breaker Q1 in case no contactor is installed.

To start up the unit from a remote location, proceed as follows:

- Put the starter switch S20 in position I (ON). Voltage is applied to the Qc2002™ module.
- Switch on circuit breaker Q1.
- For remote start:
 - Put the unit in Island mode. Push the AUTOMATIC button. Use an external switch to start the machine.
- or
- Put the unit in AMF mode. Push the AUTOMATIC button. The machine will start automatically when Mains fails.
- The unit starts a preheating cycle which takes 12 seconds.
- After the preheating period, the unit will start. The starting attempt will take maximum 12 seconds.

During operation Qc2002™

Following points should be carried out regularly:

- Check the engine gauges and the lamps for normal readings.



Avoid to let the engine run out of fuel. If it happened, priming will speed up the starting.

- Check for leakage of oil, fuel or coolant.
- Avoid long low-load periods (< 30%). In this case, an output drop and higher oil consumption of the engine could occur.
- Check, by means of the generator gauges, that the voltage between the phases is identical and that the rated current in the third phase (L3) is not exceeded.
- When single-phase loads are connected to the generator output terminals, keep all loads well-balanced.
- If circuit breakers are activated during operation, switch off the load and stop the generator. Check and, if necessary, decrease the load.



The generator's doors may only remain opened for short periods during operation, to carry out checks for example.

Stopping Qc2002™

To stop the unit , proceed as follows:

- Switch off the load.
- Switch off circuit breaker Q1.
- Let the engine run for about 5 minutes.
- Stop the engine by using the STOP button on the Qc2002™ module.
- Put the starter switch S20 in position O (OFF) to shut down the voltage apply towards the Qc2002™ module.
- Lock the side doors and the door of the indicators and control panel to avoid unauthorized access.

To stop the unit when the Qc2002™ module is in AUTOMATIC operation mode, proceed as follows:

- Switch off the load.
- For remote start:
 - When operating in Island mode, use the external switch to stop the machine.
 - When operating in AMF mode, the machine will automatically stop when the Mains returns.



When the unit is stopped with the STOP button in Automatic operation, it will automatically go to Manual Mode.

- Cooldown period default 15 sec.
- Put the starter switch S20 in position O (OFF) to shut down the voltage apply towards the Qc2002™ module.
- Lock the side doors and the door of the indicators and control panel to avoid unauthorized access.

Operating Qc4002™

Starting Qc4002™

- Turn the battery switch to ON.
- Turn the S20 button to the ON position, this will activate the Qc4002™ Controller.
- Select the correct application type and the correct mode on the Qc4002™ module (see “Overview of applications” on page 51 for the possible selections).
- Make the correct wirings and program the applicable parameters (see “Standard applications” on page 46 for more details).
- When in SEMI-AUTO mode, use the START button to start-up the generator. The GB button cannot be used to close the generator breaker.
- When in AUTO mode, the generator will start-up automatically and close the contactors depending on the selected application.



The START button, the GB-close button and the MB-close button cannot be used in AUTO mode.

During operation Qc4002™

Following points should be carried out regularly:

- Check the display for normal readings.



Avoid letting the engine run out of fuel. If this happens, priming will speed up the starting.

- Check for leakage of oil, fuel or cooling water.
- Avoid long low-load periods (< 30%). In this case, an output power drop and higher oil consumption of the engine could occur. It is recommended to operate the generator at full load capacity immediately after any low load operating period.
- When single-phase loads are connected to the generator output terminals, keep all loads well-balanced.



Never turn the optional battery switch to OFF during operation.

If circuit breaker Q1 trips off during operation, switch off the load and stop the generator. Check and, if necessary, decrease the load.

The generator’s side doors may only remain opened for short periods during operation, to carry out checks for example.

Stopping Qc4002™

- When in SEMI-AUTO mode, use the STOP button to stop the generator. The GB button will work to open the GB.
- When in AUTO mode, the STOP and GB button will not function. The generator shuts down automatically depending on the selected application



If you want to stop the generator manually, use the S20 button or the emergency stop button.

Maintenance

Maintenance schedule

 Before carrying out any maintenance activity, check that the start switch is in position O and that no electrical power is present on the terminals.

Maintenance schedule	Daily	Every 500 hours or yearly	Every 1000 hours or 24 months
Service pak	-	2912 4412 05	-
<i>For the most important subassemblies, Atlas Copco has developed service kits that combine all wear parts. These service kits offer you the benefits of genuine parts, save on administration costs and are offered at reduced price, compared to the loose components. Refer to the parts list for more information on the contents of the service kits.</i>			
Check for air, fuel, coolant and oil leakage	x	x	x
Check oil and coolant level	x	x	x
Check or drain water in fuelfilter	x	x	x
Clean air cleaner and dust bowl	x	x	x
Check/clean externally coolers	x	x	x
Check tension and condition of the drive belt	x	x	x
Check condition of cooling fan assembly	x	x	x
Replace engine oil		x	x
Replace engine oil filter		x	x
Grease door hinges and locks		x	x
Replace fuel filter element		x	x
Replace fuel prefilter element		x	x
Check electrolyte level and terminals of battery		x	x
Check fixation of hoses, cables and pipes		x	x
Grease mechanical links		x	x

Check condition of vibration dampers		X	X
Replace air filter element		X	X
Measure alternator insulation resistance		X	X
Check glycol level in coolant (1)		X	X
Check PH level of engine coolant (1)		X	X
Replace safety cartridge		X	X
Replace crankcase breather filter		X	X
Check and adjust engine inlet and outlet valves (2)			X
Check alternator and starter motor			X
Check electrical system for security of cables and wear			X
Inspection by Atlas Copco Service technician		Generators in standby application have to be tested on a regular basis. At least once a month the engine should run for minimum 30 minutes at a high load (50%-70%) that the engine reaches its operating temperature.	

Notes:

In highly dusty environments, these service intervals do not apply. Check and/or replace filters and clean radiator on a regular basis.

- (1) Change coolant every 5 years.
- (2) Gaskets rocker cover can be re-used. New gasket can be ordered with partnumber 2914 9846 00.

Engine maintenance

Refer to the engine's operator manual for full maintenance, including instructions for changing the oil and coolant and replacing the fuel, oil and air filters.

(*) Measuring the alternator insulation resistance

A 500 V megger is required to measure the alternator insulation resistance.

If the N-terminal is connected to the earthing system, it must be disconnected from the earth terminal. Disconnect the AVR.

Connect the megger between the earth terminal and terminal L1 and generate a voltage of 500 V. The scale must indicate a resistance of at least 5 MΩ.

Refer to the alternator operating and maintenance instructions for more details.

Engine fuel specifications

For fuel specifications, please contact your Atlas Copco Customer Center.

Engine oil specifications



It is strongly recommended to use Atlas Copco branded lubrication oils.

High-quality, mineral, hydraulic or synthesized hydrocarbon oil with rust and oxidation inhibitors, anti-foam and anti-wear properties is recommended. The viscosity grade should correspond to the ambient temperature and ISO 3448, as follows.

Engine	Type of lubricant
between -15°C (5°F) and 40°C (104°F)	PAROIL E
between -25°C (-13°F) and 40°C (104°F)	PAROIL Extra



Never mix synthetic with mineral oil.

When changing from mineral to synthetic oil (or the other way around), you will need to do an extra rinse.

After doing the complete change procedure to synthetic oil, run the unit for a few minutes to allow good and complete circulation of the synthetic oil. Then drain the synthetic oil again and fill again with new synthetic oil. To set correct oil levels, proceed as in normal instruction.

Specifications PAROIL

PAROIL from Atlas Copco is the ONLY oil tested and approved for use in all engines built into Atlas Copco compressors and generators.

Extensive laboratory and field endurance tests on Atlas Copco equipment have proven PAROIL to match all lubrication demands in varied conditions. It meets stringent quality control specifications to ensure your equipment will run smoothly and reliably.

The quality lubricant additives in PAROIL allow for extended oil change intervals without any loss in performance or longevity.

PAROIL provides wear protection under extreme conditions. Powerful oxidation resistance, high chemical stability and rust-inhibiting additives help reduce corrosion, even within engines left idle for extended periods.

PAROIL contains high quality anti-oxidants to control deposits, sludge and contaminants that tend to build up under very high temperatures.

PAROIL's detergent additives keep sludge forming particles in a fine suspension instead of allowing them to clog your filter and accumulate in the valve/rocker cover area.

PAROIL releases excess heat efficiently, whilst maintaining excellent bore-polish protection to limit oil consumption.

PAROIL has an excellent Total Base Number (TBN) retention and more alkalinity to control acid formation.

PAROIL prevents Soot build-up.

PAROIL is optimized for the latest low emission EURO -3 & -2, EPA TIER II & III engines running on low sulphur diesel for lower oil and fuel consumption.

PAROIL Extra and PAROIL E

Synthetic engine oil PAROIL Extra

PAROIL Extra is a Synthetic ultra high performance diesel engine oil with a high viscosity- index. Atlas Copco PAROIL Extra is designed to provide excellent lubrication from start-up in temperatures as low as -25°C (-13°F).

	Liter	US gal	Imp gal	cu.ft	Order number
can	5	1.3	1.1	0.175	1630 0135 00
can	20	5.3	4.4	0.7	1630 0136 00

Mineral engine oil PAROIL E

PAROIL E is a mineral based high performance diesel engine oil with a high viscosity- index. Atlas Copco PAROIL E is designed to provide a high level of performance and protection in standard ambient conditions as from -15°C (5°F).

	Liter	US gal	Imp gal	cu.ft	Order number
can	5	1.3	1.1	0.175	1615 5953 00
can	20	5.3	4.4	0.7	1615 5954 00
barrel	209	55.2	46	7.32	1615 5955 00
barrel	1000	264	220	35	1630 0096 00

Engine oil level check

Consult the Engine Operation Manual for the oil specifications, viscosity recommendations and oil change intervals.

For intervals, see section “Maintenance schedule” on page 61.

Check engine oil level according to the instructions in the Engine Operation Manual and if necessary top up with oil.

Engine oil and oil filter change

See section “Maintenance schedule” on page 61.

Engine coolant specifications



Never remove the cooling system filler cap while coolant is hot.

The system may be under pressure. Remove the cap slowly and only when coolant is at ambient temperature. A sudden release of pressure from a heated cooling system can result in personal injury from the splash of hot coolant.

It is strongly recommended to use Atlas Copco branded coolant.

The use of the correct coolant is important for good heat transfer and protection of liquid-cooled engines. Coolants used in these engines must be mixtures of good quality water (distilled or de-ionised), special coolant additives and if necessary freeze protection. Coolant that is not to manufacturer's specification will result in mechanical damage of the engine.

The freezing point of the coolant must be lower than the freezing point that can occur in the area. The difference must be at least 5°C (41°F). If the coolant freezes, it may crack the cylinder block, radiator or coolant pump.

Consult the engine's operation manual and follow the manufacturer's directions.



Never mix different coolants and mix the coolant components outside the cooling system.

Specifications PARCOOL EG

PARCOOL EG is the only coolant that has been tested and approved by all engine manufacturers currently in use in Atlas Copco compressors and generators.

Atlas Copco's PARCOOL EG extended life coolant is the new range of organic coolants purpose designed to meet the needs of modern engines. PARCOOL EG can help prevent leaks caused by corrosion. PARCOOL EG is also fully compatible with all sealants and gasket types developed to join different materials used within an engine.

PARCOOL EG is a ready to use Ethylene Glycol based coolant, premixed in an optimum 50/50 dilution ratio, for antifreeze protection guaranteed to -40°C (-40°F).

Because PARCOOL EG inhibits corrosion, deposit formation is minimized. This effectively eliminates the problem of restricted flow through the engine coolant ducts and the radiator, minimizing the risk for engine overheating and possible failure.

It reduces water pump seal wear and has excellent stability when subjected to sustained high operating temperatures.

PARCOOL EG is free of nitride and amines to protect your health and the environment. Longer service life reduces the amount of coolant produced and needing disposal to minimise environmental impact.

	Liter	US gal	Imp gal	cu.ft	Order number
can	5	1.3	1.1	0.175	1604 5308 00
can	20	5.3	4.4	0.7	1604 5307 01
barrel	210	55.2	46	7.35	1604 5306 00

To ensure protection against corrosion, cavitation and formation of deposits, the concentration of the additives in the coolant must be kept between certain limits, as stated by the manufacturer's guidelines. Topping up the coolant with water only, changes the concentration and is therefore not allowed.

Liquid-cooled engines are factory-filled with this type of coolant mixture.

Coolant check

Monitoring coolant condition

In order to guarantee the lifetime and quality of the product, thus to optimise engine protection, regular coolant-condition-analysis is advisable.

The quality of the product can be determined by three parameters.

Visual check

- Verify the outlook of the coolant regarding colour and make sure that no loose particles are floating around.



Long service intervals

5-year drain interval to minimize service costs (when used in accordance with the instructions).

pH measurement

- Check the pH value of the coolant using a pH-measuring device.
- The pH-meter can be ordered from Atlas Copco with part number 2913 0029 00.
- Typical value for EG = 8.6.
- If the pH-level is below 7 or above 9.5, the coolant should be replaced.

Glycol concentration measurement

- To optimise the unique engine protection features of the PARCOOL EG the concentration of the Glycol in the water should be always above 33 vol.%.
- Mixtures with more than 68 vol.% mix ratio in water are not recommended, as this will lead to high engine operating temperatures.
- A refractometer can be ordered from Atlas Copco with part number 2913 0028 00.



In case of a mix of different coolant products this type of measurement might provide incorrect values.

Topping up of coolant

- Verify if the engine cooling system is in a good condition (no leaks, clean,...).
- Check the condition of the coolant.
- If the condition of the coolant is outside the limits, the complete coolant should be replaced (see section “Replacing the coolant”).
- Always top-up with PARCOOL EG.
- Topping up the coolant with water only, changes the concentration of additives and is therefore not allowed.

Replacing the coolant

Drain

- Completely drain the entire cooling system.
- Used coolant must be disposed or recycled in accordance with laws and local regulations.

Flush

- Flush twice with clean water. Used coolant must be disposed or recycled in accordance with laws and local regulations.
- From the Atlas Copco Instruction book, determine the amount of PARCOOL EG required and pour into the radiator top tank.
- It should be clearly understood that the risk for contamination is reduced in case of proper cleaning.
- In case a certain content of ‘other’ coolant remains in the system, the coolant with the lowest properties influences the quality of the ‘mixed’ coolant.

Fill

- To assure proper operation and the release of trapped air, run the engine until normal engine operation temperature is reached. Turn off the engine and allow to cool.
- Recheck coolant level and add if necessary.

Storage of the generator

Storage

- Store the generator in a dry, frost-free room which is well ventilated.
- Run the engine regularly, e.g. once a week, until it is warmed up. If this is impossible, extra precautions must be taken:
 - Consult the engine's operator manual.
 - Remove the battery. Store it in a dry, frost-free room. Keep the battery clean and its terminals lightly covered with petroleum jelly. Recharge the battery regularly.
 - Clean the generator and protect all electrical components against moisture.
 - Place silica gel bags, VCI paper (Volatile Corrosion Inhibitor) or another drying agent inside the generator and close the doors.
 - Stick sheets of VCI paper with adhesive tape on the bodywork to close off all openings.
 - Wrap the generator, except the bottom, with a plastic bag.

Preparing for operation after storage

Before operating the generator again, remove the wrapping, VCI paper and silica gel bags and check the generator thoroughly (go through the checklist "Before starting" on page 57).

- Consult the engine's operator manual.
- Check that the insulation resistance of the generator exceeds 5 M Ω .
- Replace the fuel filter and fill the fuel tank. Vent the fuel system.
- Reinstall and connect the battery, if necessary after being recharged.
- Submit the generator to a test run.

Checks and trouble shooting



Never perform a test run with connected power cables. Never touch an electrical connector without a voltage check.

When a failure occurs, always report what you experienced before, during and after the failure. Information with regard to the load (type, size, power factor, etc.), vibrations, exhaust gas colour, insulation check, odours, output voltage, leaks and damaged parts, ambient temperature, daily and normal maintenance and altitude might be helpful to quickly locate the problem. Also report any information regarding the humidity and location of the generator (e.g. close to sea).

Checking voltmeter P4

- Put a voltmeter in parallel with voltmeter P4 on the control panel.
- Check that the read-out of both voltmeters is the same.
- Stop the generator and disconnect one terminal.
- Check that the internal resistance of the voltmeter is high.

Checking ammeters P1, P2 and P3

- Measure the outgoing current during the load, by means of a clamp-on probe.
- Compare the measured current with the current indicated on ammeter. Both readings should be the same.

Alternator troubleshooting

<i>Symptom</i>	<i>Possible cause</i>	<i>Corrective action</i>
<i>Alternator gives 0 Volt</i>	Blown fuse. No residual voltage.	Replace fuse. Excite the alternator by applying a 12V battery voltage with a 30 Ω resistor in series on the + and - terminals of the electronic regulator, respecting the polarities.
<i>After being excited the alternator still gives 0 Volt.</i>	Connections are interrupted.	Check connection cables, measure winding resistances and compare with values mentioned in the alternator manual.
<i>Low voltage at no load</i>	Voltage potentiometer out of setting. Intervention of protection. Winding failure.	Reset voltage. Check frequency/voltage regulator. Check windings.
<i>High voltage at no load</i>	Voltage potentiometer out of setting. Failed regulator.	Reset voltage. Substitute regulator.
<i>Lower than rated voltage at load</i>	Voltage potentiometer out of setting. Intervention by protection. Failed regulator. Rotating bridge failure.	Reset voltage potentiometer. Current too high, power factor lower than 0.8; speed lower than 10% of rated speed. Substitute regulator. Check diodes, disconnect cables.
<i>Higher than rated voltage at load</i>	Voltage potentiometer out of setting. Failed regulator.	Reset voltage potentiometer. Substitute regulator.
<i>Unstable voltage</i>	Speed variation in engine. Regulator out of setting.	Check regularity of rotation. Regulate stability of regulator by acting on STABILITY potentiometer.

Engine trouble shooting

The table below gives an overview of the possible engine problems and their possible causes.

The starter motor turns the engine too slowly

- Battery capacity too low.
- Bad electrical connection.
- Fault in starter motor.
- Wrong grade of lubricating oil.

The engine does not start or is difficult to start

- Starter motor turns engine too slowly.
- Fuel tank empty.
- Fault in fuel control solenoid.
- Restriction in a fuel pipe.
- Fault in fuel lift pump.
- Dirty fuel filter element.
- Air in fuel system.
- Fault in atomisers.
- Cold start system used incorrectly.
- Fault in cold start system.
- Restriction in fuel tank vent.
- Wrong type or grade of fuel used.
- Restriction in exhaust pipe.

Not enough power

- Restriction in a fuel pipe.
- Fault in fuel lift pump.
- Dirty fuel filter element.
- Restriction in air filter/cleaner or induction system.
- Air in fuel system.
- Fault in atomisers or atomisers of an incorrect type.
- Restriction in fuel tank vent.
- Wrong type or grade of fuel used.
- Restricted movement of engine speed control.
- Restriction in exhaust pipe.
- Engine temperature is too high.
- Engine temperature is too low.

Misfire

- Restriction in a fuel pipe.
- Fault in fuel lift pump.
- Dirty fuel filter element.
- Air in fuel system.
- Fault in atomisers or atomisers of an incorrect type.
- Fault in cold start system.
- Engine temperature is too high.

- Incorrect valve tip clearances.

The pressure of the lubricating oil is too low

- Wrong grade of lubricating oil.
- Not enough lubricating oil in sump.
- Defective gauge.
- Dirty lubricating oil filter element.

High fuel consumption

- Restriction in air filter/cleaner or induction system.
- Fault in atomisers or atomisers of an incorrect type.
- Fault in cold start system.
- Wrong type or grade of fuel used.
- Restricted movement of engine speed control.
- Restriction in exhaust pipe.
- Engine temperature is too low.
- Incorrect valve tip clearances.

Black exhaust smoke

- Restriction in air filter/cleaner or induction system.
- Fault in atomisers or atomisers of an incorrect type.
- Fault in cold start system.
- Wrong type or grade of fuel used.
- Restriction in exhaust pipe.
- Engine temperature is too low.
- Incorrect valve tip clearances.
- Engine overload.

Blue or white exhaust smoke

- Wrong grade of lubricating oil.
- Fault in cold start system.
- Engine temperature is too low.

The engine knocks

- Fault in fuel lift pump.
- Fault in atomisers or atomisers of an incorrect type.
- Fault in cold start system.
- Wrong type or grade of fuel used.
- Engine temperature is too high.
- Incorrect valve tip clearances.

The engine runs erratically

- Fault in fuel control.
- Restriction in a fuel pipe.
- Fault in fuel lift pump.
- Dirty fuel filter element.
- Restriction in air filter/cleaner or induction system.
- Air in fuel system.
- Fault in atomisers or atomisers of an incorrect type.
- Fault in cold start system.
- Restriction in fuel tank vent.
- Restricted movement of engine speed control.
- Engine temperature is too high.
- Incorrect valve tip clearances.

Vibration

- Fault in atomisers or atomisers of an incorrect type.
- Restricted movement of engine speed control.
- Engine temperature is too high.
- Fan damaged.
- Fault in engine mounting or flywheel housing.

The pressure of the lubricating oil is too high

- Wrong grade of lubricating oil.
- Defective gauge.

The engine temperature is too high

- Restriction in air filter/cleaner or induction system.
- Fault in atomisers or atomisers of an incorrect type.
- Fault in cold start system.
- Restriction in exhaust pipe.
- Fan damaged.
- Too much lubricating oil in sump.
- Restriction in air or coolant passages of radiator.
- Insufficient coolant in system.

Crankcase pressure

- Restriction in breather pipe.
- Vacuum pipe leaks or fault in exhauster.

Bad compression

- Restriction in air filter/cleaner or induction system.
- Incorrect valve tip clearances.

The engine starts and stops

- Dirty fuel filter element.
- Restriction in air filter/cleaner or induction system.
- Air in fuel system.

The engine shuts down after approx. 15 sec.

- Bad connection towards oil pressure switch/coolant temperature switch.

Options available for QAS 60, QAS 80 and QAS 100 units

Circuit diagrams

The engine control circuit diagrams and the power circuit diagrams for the standard QAS 60, QAS 80 and QAS 100 units:

Power circuit

<i>Unit</i>	<i>Circuit</i>
QAS 60-80-100 Pd	9822 0996 00
QAS 60-80-100 Pd - 2V-50Hz 1ph	9822 0996 01
QAS 60-80-100 Pd - 2V-50 Hz	9822 0996 02

Controller circuit

<i>Unit</i>	<i>Circuit</i>
QAS 60-80-100 Pd Qc1002™	9822 0996 05
QAS 60-80-100 Pd Qc2002™	9822 0996 06
QAS 60-80-100 Pd Qc4002™	9822 0996 08

Overview of the electrical options

The following electrical options are available for the QAS 60, QAS 80 and QAS 100 units:

- Automatic battery charger
- Battery switch
- Engine coolant heater
- Outlet sockets (S) - Set 1
- Outlet sockets (S) - Set 2
- Outlet sockets (S) - Set 3 QAS 60-80 Pd
- Outlet sockets (S) - Set 3 QAS 100 Pd
- Single frequency with electronic speed control (SF)
- Dual frequency with electronic speed control (DF)
- Electronic speed regulator
- Low voltage (LV)
- Dual voltage (2V)
- Earth leakage relay
- IT-relay
- “Electricité de France” (EDF)
- COSMOS™

Description of the electrical options



The positioning of the components mentioned in the description of the QAS 60-80-100 options, may differ slightly depending on the generator model.

Automatic battery charger

The automatic battery charger charges the battery completely and is disconnected once the unit starts up.

Besides the output terminals (secondary side) the automatic battery charger has a trim potentiometer for setting of the output voltage. By means of an insulated slotted screwdriver or adjusting pin the output voltage can be set in the range 23.5-27.5 V respectively 11.8-13.8 V.

The LED on the front indicates that the unit is operational.

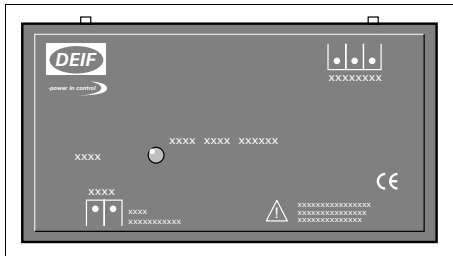

Setting:

- Lower output voltage = Counterclockwise rotation
- Higher output voltage = Clockwise rotation

To use the battery charger:

- Provide the X25 connector, located at the side of the power cubicle, with external power to use the battery charger.



The automatic battery charger is standard on units with Qc2002™ or Qc4002™ controller.

Battery switch

The battery switch is situated inside the sound-insulated bodywork. It allows to open or to close the electrical connection between the battery and the engine circuits.



Never turn the battery switch to OFF during operation.

Engine coolant heater

To make sure that the engine can start and accept load immediately, an external coolant heater (1000 W, 240 V) is provided which keeps the engine temperature between 38°C and 49°C.

Outlet sockets (S) - Set 1

A brief description of all outlet sockets and circuit breakers provided on the generator is given hereafter:

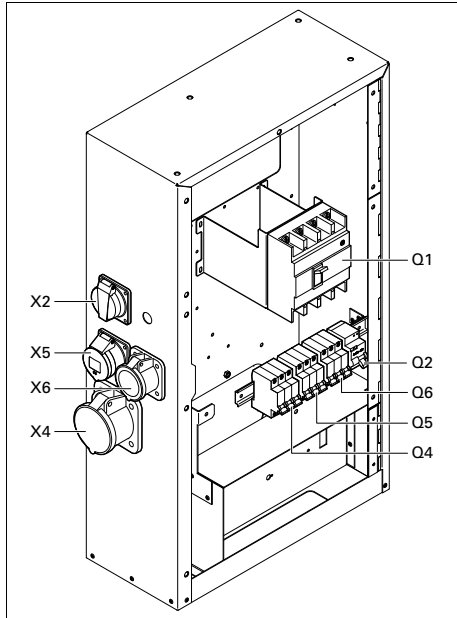

X2 1-phase outlet socket (230 V AC)

Provides phase L3, neutral and earthing.

X4 3-phase outlet socket (400 V AC)

Provides phases L1, L2 and L3, neutral and earthing.

X5 3-phase outlet socket (400 V AC)

Provides phases L1, L2 and L3, neutral and earthing.

X6 3-phase outlet socket (400 V AC)

Provides phases L1, L2 and L3, neutral and earthing.

Q2 Circuit breaker for X2

Interrupts the power supply to X2 when a short-circuit occurs at the load side, or when the overcurrent protection (16 A) is activated. When activated, Q2 interrupts phase L3 and the neutral towards X2. It can be activated again after eliminating the problem.

Q4 Circuit breaker for X4

Interrupts the power supply to X4 when a short-circuit occurs at the load side, or when the overcurrent protection (63 A) is activated. When activated, Q4 interrupts the three phases towards X4. It can be activated again after eliminating the problem.

Q5 Circuit breaker for X5

Interrupts the power supply to X5 when a short-circuit occurs at the load side, or when the overcurrent protection (32 A) is activated. When activated, Q5 interrupts the three phases towards X5. It can be activated again after eliminating the problem.

Q6 Circuit breaker for X6

Interrupts the power supply to X6 when a short-circuit occurs at the load side, or when the overcurrent protection (16 A) is activated. When activated, Q6 interrupts the three phases towards X6. It can be activated again after eliminating the problem.



Circuit breaker Q1 does not only interrupt the power supply towards X1, but also towards X2, X4, X5 and X6.

Make sure to switch on circuit breakers Q1, Q2, Q4, Q5 and Q6 after starting the generator when power supply is done by means of X2, X4, X5 or X6.

Outlet sockets (S) - Set 2

A brief description of all outlet sockets and circuit breakers provided on the generator is given hereafter:

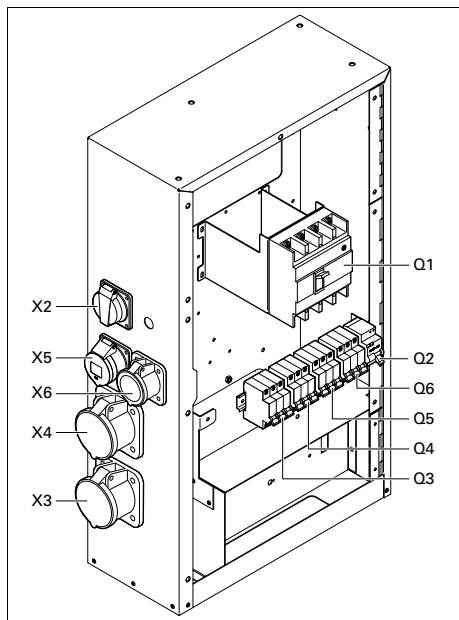

X2..... 1-phase outlet socket (230 V AC)

Provides phase L3, neutral and earthing.

X3..... 3-phase outlet socket (400 V AC)

Provides phases L1, L2 and L3, neutral and earthing.

X4..... 3-phase outlet socket (400 V AC)

Provides phases L1, L2 and L3, neutral and earthing.

X5..... 3-phase outlet socket (400 V AC)

Provides phases L1, L2 and L3, neutral and earthing.

X6..... 3-phase outlet socket (400 V AC)

Provides phases L1, L2 and L3, neutral and earthing.

Q2..... Circuit breaker for X2

Interrupts the power supply to X2 when a short-circuit occurs at the load side, or when the overcurrent protection (16 A) is activated. When activated, Q2 interrupts phase L3 and the neutral towards X2. It can be activated again after eliminating the problem.

Q3..... Circuit breaker for X3

Interrupts the power supply to X3 when a short-circuit occurs at the load side, or when the overcurrent protection (63 A) is activated. When activated, Q3 interrupts the three phases towards X3. It can be activated again after eliminating the problem.

Q4..... Circuit breaker for X4

Interrupts the power supply to X4 when a short-circuit occurs at the load side, or when the overcurrent protection (63 A) is activated. When activated, Q4 interrupts the

three phases towards X4. It can be activated again after eliminating the problem.

Q5..... Circuit breaker for X5

Interrupts the power supply to X5 when a short-circuit occurs at the load side, or when the overcurrent protection (32 A) is activated. When activated, Q5 interrupts the three phases towards X5. It can be activated again after eliminating the problem.

Q6..... Circuit breaker for X6

Interrupts the power supply to X6 when a short-circuit occurs at the load side, or when the overcurrent protection (16 A) is activated. When activated, Q6 interrupts the three phases towards X6. It can be activated again after eliminating the problem.



Circuit breaker Q1 does not only interrupt the power supply towards X1, but also towards X2, X3, X4, X5 and X6.

Make sure to switch on circuit breakers Q1, Q2, Q3, Q4, Q5 and Q6 after starting the generator when power supply is done by means of X2, X3, X4, X5 or X6.

Outlet sockets (S) - Set 3 QAS 60-80 Pd

A brief description of all outlet sockets and circuit breakers provided on the generator is given hereafter:

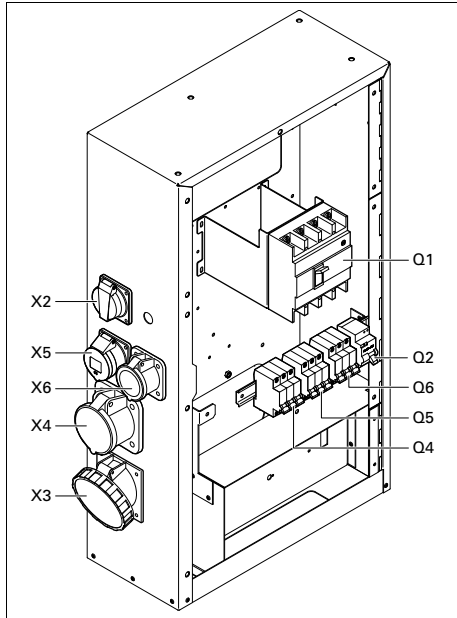

X2.....1-phase outlet socket (230 V AC)

Provides phase L3, neutral and earthing.

X3.....3-phase outlet socket (400 V AC)

Provides phases L1, L2 and L3, neutral and earthing.

X4.....3-phase outlet socket (400 V AC)

Provides phases L1, L2 and L3, neutral and earthing.

X5.....3-phase outlet socket (400 V AC)

Provides phases L1, L2 and L3, neutral and earthing.

X6.....3-phase outlet socket (400 V AC)

Provides phases L1, L2 and L3, neutral and earthing.

Q2.....Circuit breaker for X2

Interrupts the power supply to X2 when a short-circuit occurs at the load side, or when the overcurrent protection (16 A) is activated. When activated, Q2 interrupts phase L3 and the neutral towards X2. It can be activated again after eliminating the problem.

Q4.....Circuit breaker for X4

Interrupts the power supply to X4 when a short-circuit occurs at the load side, or when the overcurrent protection (63 A) is activated. When activated, Q4 interrupts the three phases towards X4. It can be activated again after eliminating the problem.

Q5.....Circuit breaker for X5

Interrupts the power supply to X5 when a short-circuit occurs at the load side, or when the overcurrent protection (32 A) is activated. When activated, Q5 interrupts the three phases towards X5. It can be activated again after eliminating the problem.

Q6.....Circuit breaker for X6

Interrupts the power supply to X6 when a short-circuit occurs at the load side, or when the overcurrent protection (16 A) is activated. When activated, Q6 interrupts the three phases towards X6. It can be activated again after eliminating the problem.



Circuit breaker Q1 does not only interrupt the power supply towards X1, but also towards X2, X3, X4, X5 and X6.

Make sure to switch on circuit breakers Q1, Q2, Q4, Q5 and Q6 after starting the generator when power supply is done by means of X2, X3, X4, X5 or X6.

Outlet sockets (S) - Set 3 QAS 100 Pd

A brief description of all outlet sockets and circuit breakers provided on the generator is given hereafter:

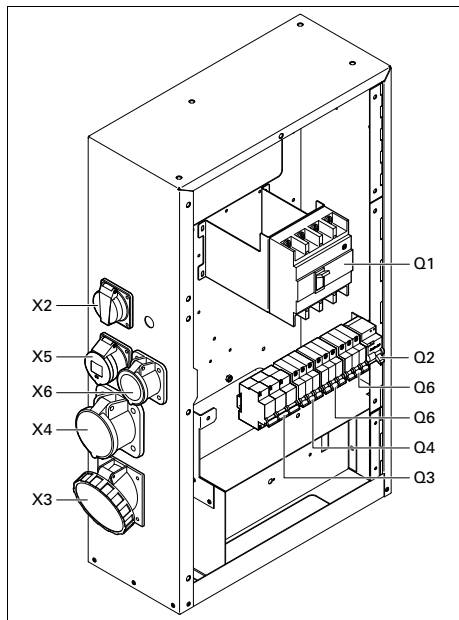

X2 1-phase outlet socket (230 V AC)

Provides phase L3, neutral and earthing.

X3 3-phase outlet socket (400 V AC)

Provides phases L1, L2 and L3, neutral and earthing.

X4 3-phase outlet socket (400 V AC)

Provides phases L1, L2 and L3, neutral and earthing.

X5 3-phase outlet socket (400 V AC)

Provides phases L1, L2 and L3, neutral and earthing.

X6 3-phase outlet socket (400 V AC)

Provides phases L1, L2 and L3, neutral and earthing.

Q2 Circuit breaker for X2

Interrupts the power supply to X2 when a short-circuit occurs at the load side, or when the overcurrent protection (16 A) is activated. When activated, Q2 interrupts phase L3 and the neutral towards X2. It can be activated again after eliminating the problem.

Q3 Circuit breaker for X3

Interrupts the power supply to X3 when a short-circuit occurs at the load side, or when the overcurrent protection (125 A) is activated. When activated, Q3 interrupts the three phases towards X3. It can be activated again after eliminating the problem.

Q4 Circuit breaker for X4

Interrupts the power supply to X4 when a short-circuit occurs at the load side, or when the overcurrent protection (63 A) is activated. When activated, Q4 interrupts the three phases towards X4. It can be activated again after eliminating the problem.

Q5 Circuit breaker for X5

Interrupts the power supply to X5 when a short-circuit occurs at the load side, or when the overcurrent protection (32 A) is activated. When activated, Q5 interrupts the three phases towards X5. It can be activated again after eliminating the problem.

Q6 Circuit breaker for X6

Interrupts the power supply to X6 when a short-circuit occurs at the load side, or when the overcurrent protection (16 A) is activated. When activated, Q6 interrupts the three phases towards X6. It can be activated again after eliminating the problem.



Circuit breaker Q1 does not only interrupt the power supply towards X1, but also towards X2, X3, X4, X5 and X6.

Make sure to switch on circuit breakers Q1, Q2, Q3, Q4, Q5 and Q6 after starting the generator when power supply is done by means of X2, X3, X4, X5 or X6.

Single frequency with electronic speed control (SF)

The Single frequency option provides an electric speed controller which improves the output frequency of the generator at 50 Hz/60 Hz at constant load.

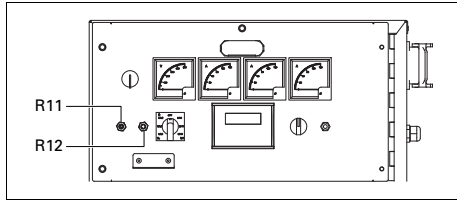

R11 *Supply voltage adjust potentiometer*

See “Electronic speed regulator”.

R12 *Voltage adjustment*

Allows to adjust the output voltage.



Single frequency with electronic speed control is standard for the QAS 80-100 Pd.

It is not available for units with Qc4002™ controller.

Dual frequency with electronic speed control (DF)

The Dual frequency with electronic speed control option allows the unit to work at 50 Hz or at 60 Hz at constant load. The frequency selection is done by means of switch S12.

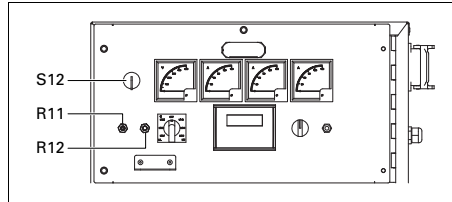

R11 *Speed adjustment*

See “Electronic speed regulator”.

R12 *Voltage adjustment*

Allows to adjust the output voltage.

S12 *Frequency selector switch (50 Hz/60 Hz)*

Allows to choose the frequency of the output voltage: 50 Hz or 60 Hz.



Changing the output frequency is only allowed after shutdown.

After changing the output frequency, adjust the output voltage by means of potentiometer R12 to the required value.

Dual frequency with electronic speed control is standard for units with Qc4002™ controller.

Electronic speed regulator

The electronic speed regulator makes sure that the output frequency of the generator is 50 Hz/60 Hz, independent of the amount of load.

Low voltage (LV)

The Low voltage option allows to run the unit at low voltage (= high current).



All the cables that are used must be suitable for high current.

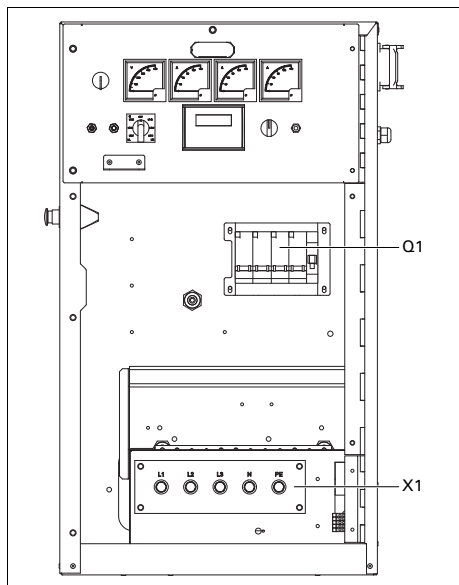

Q1.....Circuit breaker for low voltage, high current

Interrupts the low voltage power supply towards X1 when a short-circuit occurs at the load side or when the overcurrent protection (QAS 60: 175 A, QAS 80: 237 A, QAS 100: 280 A) is activated. It must be reset manually after eliminating the problem.

Dual voltage (2V)



The dual voltage option is only available on 50 Hz units with Qc1002™ controller.

1 phase - 3 phase

The generator can run in two different modes:

1 phase, lower voltage

When using this selection, the generator provides a 230 V output voltage.

3 phase, higher voltage

When using this selection, the generator provides a 400 V output voltage.

3 phase - 3 phase

3 phase, lower voltage

When using this selection, the generator provides a 230 V output voltage. (IT = active)

3 phase, higher voltage

When using this selection, the generator provides a 400 V output voltage. (ELR = active)

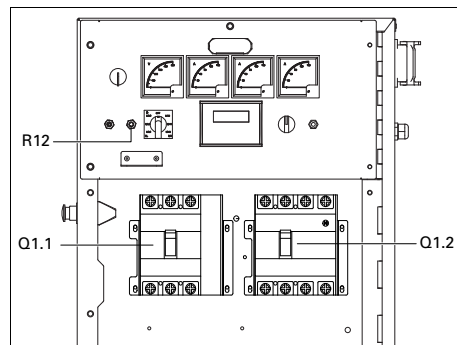

Q1.1....Circuit breaker for low voltage, high current

Interrupts the low voltage power supply towards X1 when a short-circuit occurs at the load side or when the overcurrent protection (1 phase - 3 phase: QAS 60: 175 A, QAS 80: 250 A, QAS 100: 280 A / 3 phase - 3 phase: QAS 60: 152 A, QAS 80: 200 A, QAS 100: 250 A) is activated. It must be reset manually after eliminating the problem.

Q1.2....Circuit breaker for high voltage, low current

Interrupts the high voltage power supply towards X1 when a short-circuit occurs at the load side or when the overcurrent protection (QAS 60: 100 A, QAS 80: 125 A, QAS 100: 144 A) is activated. It must be reset manually after eliminating the problem.

R12 Voltage adjustment

Allows to adjust the output voltage.



AMF operation is not possible with a dual voltage generator.

Depending on which mode the generator is running in, circuit breaker Q1.1 or Q1.2 will be operational.

Circuit breakers Q1.1 and Q1.2 cannot be switched on at the same time. This is prevented by means of the auxiliary voltage selection relays K11 and K12 (refer to circuit diagram 9822 0996 01/01) or S10b and S10c (refer to circuit diagram 9822 0996 02/01).

The selection between the two modes is done by means of S10.

S10 Output voltage selection switch

Allows to select a 3 phase high output voltage or a 1 phase / 3 phase low output voltage. Selector switch S10 is located on the alternator.



Changing the output voltage is only allowed when the unit has stopped. After changing the output voltage by means of the selection switch S10, adjust the output voltage by means of potentiometer R12 to the required value.

Earth leakage relay

The Earth relay option provides a detector that will trip the main circuit breaker Q1 when an earth fault current is detected.

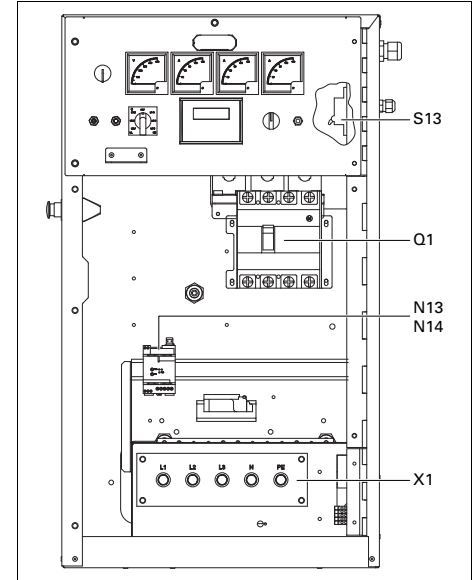

Q1 Main circuit breaker

N13.....Earth leak detector

Detects and indicates an earth fault current and activates the main circuit breaker Q1. The detection level can be set at 30 mA fixed with instantaneous trip but can also be adjusted between 0.1 A and 1 A with time delayed (0 - 0.5 sec) trip. N13 has to be reset manually after eliminating the problem (reset button marked R). It can be overridden by means of the earth leak switch (S13, labelled IΔN) but has to be tested monthly by pushing test button T13.

S13Lock-out switch for earth fault protection (N13)

This switch is located inside the cubicle and is labelled IΔN.

Position O: No de-energising of the main circuit breaker Q1 when an earth fault occurs.

Position I: De-energising of the main circuit breaker Q1 when an earth fault occurs.



Position O will only be used in conjunction with an external earth fault protection unit (e.g. integrated in a distribution board).

If S13 is in position O, proper earthing is of the utmost importance for the safety of the user. Eliminating any earth fault protection can lead to serious injury or even death for anybody touching the unit or the load.

IT-relay

The generator is wired for an IT network i.e. no supply lines of the power supply are directly earthed. A failure in insulation resulting in a too low insulation resistance, is detected by the insulation monitoring relay.



The generator shall not be operated with other networks (such as TT or TN). Doing so will cause tripping of the insulation monitoring relay.

The generator is wired for an IT network i.e. no supply lines of the power supply are directly earthed. A failure in insulation resulting in too low an insulation resistance, is detected by the insulation monitoring relay.

At each start-up and any time a new load is connected, the insulation resistance must be verified. Check for the correct setting of the insulation monitoring relay (factory set at 13 kΩ).

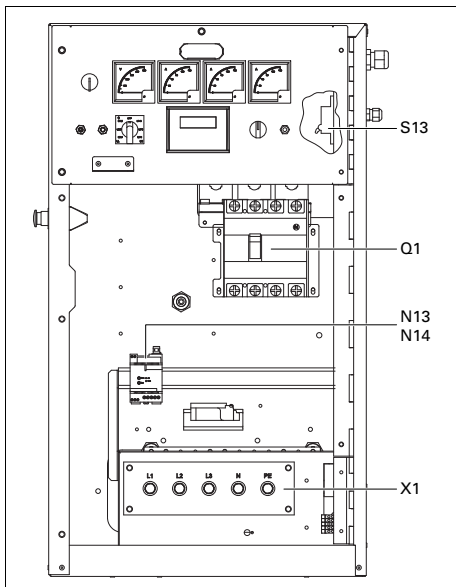

Q1..... Circuit breaker for X1

Interrupts the power supply X1 when a short-circuit occurs at the load side, or when the overcurrent protection is activated. When activated, Q1 interrupts the three phases towards X1. It must be reset manually after eliminating the problem.

X1 Main power supply (400 Vac)

Terminals L1, L2, L3, N (= neutral) and PE (= earthing), hidden behind the control panel door and behind a small transparent door.

N14..... Insulation monitoring relay

Checks the insulation resistance and activates Q1 when the insulation resistance is too low.

S2 Emergency stop button

Push the button to stop the generator in case of an emergency. When the button is pressed, it must be unlocked, by turning it anti-clockwise, before the generator can be restarted. The emergency stop button can be secured in the locked position with the key, to avoid unauthorized use.

“Electricité de France” (EDF)

When the EDF-option is installed, the unit operates as a standard unit when the neutral and the PE terminals are connected to each other (see figure below). In this case, an earth leakage at the side of the generator or at the side of the load will switch off the circuit breaker.

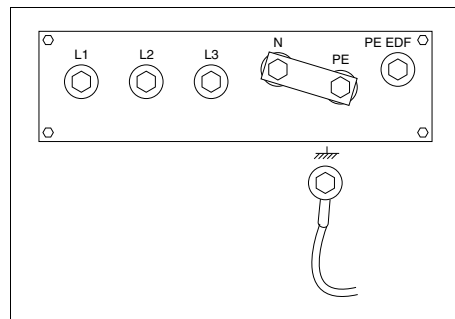

When EDF-option is installed, the unit operates as EDF-unit when the earthing, the PE and the PE EDF terminals are connected to each other (see figure below). In this case, an earth leakage at the side of the generator will switch off the circuit breaker. An earth leakage at the side of the load will not switch off the circuit breaker.

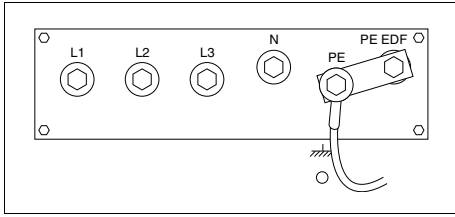

Changing the operation mode from standard unit to EDF-unit or vice versa has to be carried out by a qualified person from “Electricité de France”.

COSMOS™

COSMOS™ is a web-based global remote monitoring system that electronically tracks every aspect of equipment from its location to its operating parameters. The Cosmos system can send e-mails or SMS messages to the contractor or owner in real time, with all critical and non-critical events and data involving your compressors and generators. It allows optimal servicing.

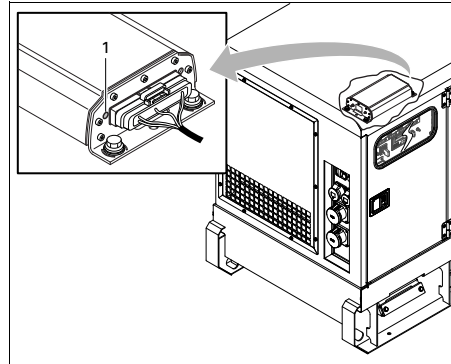

When starting up the generator, the green Power Led (1) of the Cosmos module will light up when the installation has been carried out correctly.

For information about COSMOS™, consult your local Atlas Copco dealer.

Overview of the mechanical options

The following mechanical options are available for the QAS 60, QAS 80 and QAS 100 units:

- External fueltank connection (with/without quick couplings)
- Undercarriage (axle, towbar, towing eyes)
- Skid fueltank
- Integrated spark arrestor
- Air inlet shut-off valve

Description of the mechanical options

External fueltank connection (with/without quick couplings)

The option external fueltank connection allows to bypass the internal fueltank and to connect an external fueltank to the unit.

View outside

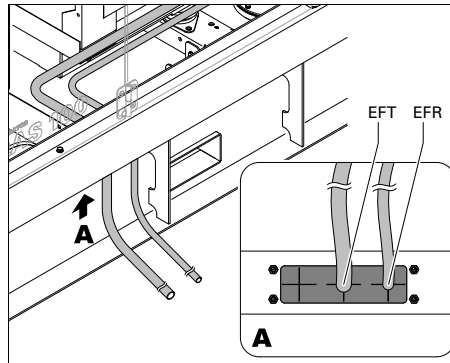

View inside

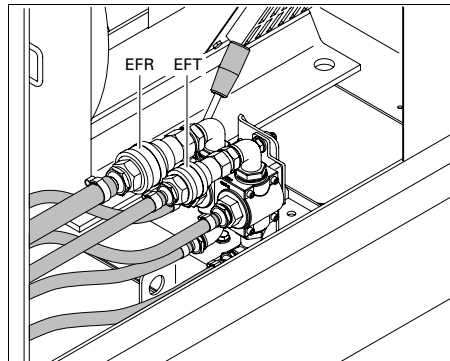

EFT | External fuel tank feed connection
EFR | External fuel tank return connection

When using this option, make sure to connect the fuel supply line as well as the fuel return line. Connections to fuellines ought to be air-tight to prevent air from entering the fuel system. Turn the handle of 3-way valve to desired condition.

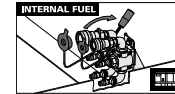

Internal fuel: Indicates that the fuel supply line to the engine is connected to the internal fueltank.

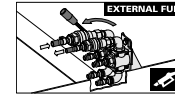

External fuel: Indicates that the fuel supply line to the engine is connected to the external fueltank.

Undercarriage (axle, towbar, towing eyes)

The undercarriage is equipped with an adjustable towbar with brakes, with BNA-, NATO-, DIN-, ITA-, ISO-eye and Ball coupling and with road signalisation which is approved by EC legislation.

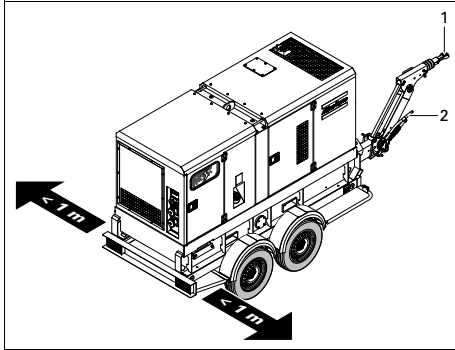

When using this option

- Make sure that the towing equipment of the vehicle matches the towing eye before towing (1) the generator.
- Never move the generator while electrical cables are connected to the unit.
- Always apply the hand brake (2) when parking the generator.
- Leave enough space for operation, inspection and maintenance (at least 1 meter at each side).

To maintain the undercarriage

- Check the tightness of the towbar bolts, the axle bolts and the wheel nuts at least twice a year and after the initial 50 hours of operation.
- Grease the wheel axle suspension bearings, the drawbar to the steering gear shaft and the spindle of the brake handle at least twice a year. Use ball bearing grease for the wheel bearings and graphite grease for the drawbar and spindle.
- Check the brake system twice a year.
- Check the condition of the vibration dampers twice a year.
- Repack the wheel hub bearings once a year using grease.
- Wheel chocks allows to park the generator on sloping ground. Place wheel chocks in front of or behind the wheels to immobilize the generator.

Integrated spark arrestor

The integrated spark arrestor option is included in the refinery equipment pack.

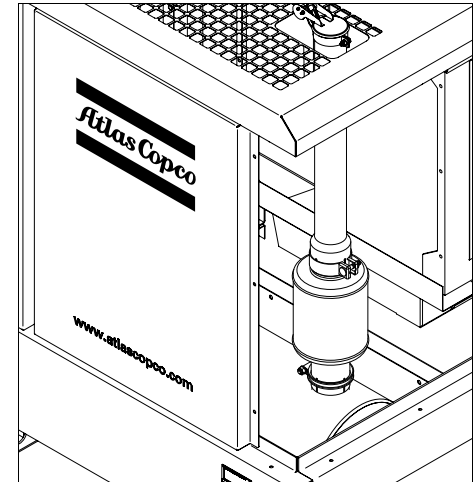

Air inlet shut-off valve

The engine air inlet shut-off valve option is included in the refinery equipment pack. It will prevent over-speeding of the engine due to combustible gases being traced within the normal engine air intake.

Technical specifications

Technical specifications for QAS 60 units

Readings on gauges

<i>Gauge</i>	<i>Reading</i>	<i>Unit</i>
Ammeter L1-L3 (P1-P3)	Below max. rating	A
Voltmeter (P4)	Below max. rating	V

Settings of switches

<i>Switch</i>	<i>Function</i>	<i>Activates at</i>
Engine oil pressure	Shut down	0.5 bar
Engine coolant temperature	Shut down	103°C

Specifications of the engine/alternator/unit

		<i>50 Hz</i>	<i>60 Hz</i>
<i>Reference conditions 1) 4)</i>	Rated frequency	50 Hz	60 Hz
	Rated speed (optional)	1500 rpm	1800 rpm
	Generator service duty	PRP	PRP
	Absolute air inlet pressure	100 kPa	100 kPa
	Relative air humidity	30%	30%
	Air inlet temperature	25°C	25°C
<i>Limitations 2)</i>	Maximum ambient temperature	50°C	50°C
	Altitude capability	4000 m	4000 m
	Maximum relative air humidity	85%	85%
	Minimum starting temperature unaided	-18°C	-18°C
	Minimum starting temperature aided (optional)	-25°C	-25°C
<i>Performance data 2) 3) 5)</i>	Rated active power (PRP) 3ph	47 kW	54.6 kW
	Rated active power (PRP) 1ph (optional)	40 kW	45 kW

Application data

Rated power factor (lagging) 3ph	0.8 cos ϕ	0.8 cos ϕ
Rated power factor (lagging) 1ph (optional)	1 cos ϕ	1 cos ϕ
Rated PRP power 3ph	58.8 kVA	68.3 kVA
Rated PRP power 1ph (optional)	40 kVA	45 kVA
Rated voltage 3ph line to line	400 V	480 V
Rated voltage 3ph line to line lower voltage	230 V	240 V
Rated voltage 1ph (optional)	230 V	240 V
Rated current 3ph	84.9 A	82.2 A
Rated current 3ph lower voltage	147.6 A	164.3 A
Rated current 1ph (optional)	173.9 A	187.5 A
Performance class (acc.ISO 8528-5:1993)	G2	G2
Single step load acceptance (0-PRP)	100%	TBA
Frequency droop (optional)	< 5%	< 5%
	isochronous	isochronous
Fuel consumption at no load (0%)	1.8 kg/h	2.4 kg/h
Fuel consumption at 50% load	6.1 kg/h	7.5 kg/h
Fuel consumption at 75% load	8.4 kg/h	10.4 kg/h
Fuel consumption at full load (100%)	11.3 kg/h	13.4 kg/h
Specific fuel consumption at full load (100%)	0.239 kg/kWh	0.245 kg/kWh
Fuel autonomy at full load with standard tank	17.4 h	14.7 h
Fuel autonomy at full load with standard tank and optional skid fuel tank	41.3 h	34.5 h
Max. oil consumption at full load	16.9 g/h	TBA
Maximum sound power level (LWA) measured according to 2000/14/EC OND	87 dB(A)	90 dB(A)
Capacity of fuel tank	230 l	230 l
Capacity of optional skid fuel tank	545 l	545 l
Single step load acceptance	100%	TBA
Mode of operation	PRP	PRP
Site	land use	land use
Operation	single	single
Start-up and control mode	manual/automatic	manual/automatic
Start-up time	unspecified	unspecified

	Mobility/Config. acc. to ISO 8528-1:1993 (optional)	transportable/D mobile/E	transportable/D mobile/E
	Mounting	fully resilient	fully resilient
	Climatic exposure	open air	open air
	Degree of protection (cubicle)	IP 54	IP 54
	Status of neutral (TT or NT)	earthed	earthed
	Status of neutral (IT) (optional)	insulated	-
<i>Alternator 4)</i>	Standard	IEC34-1	IEC34-1
		ISO 8528-3	ISO 8528-3
	Make	CUMMINS	CUMMINS
	Model	UCI224-E1	UCI224-E1
	Rated output, class H temperature rise	60 kVA	75 kVA
	rating type acc. ISO 8528-3	BR	BR
	Degree of protection	IP 23	IP 23
	Insulation stator class	H	H
	Insulation rotor class	H	H
	Number of wires	12	12
<i>Engine 4)</i>	Standard	ISO 3046	ISO 3046
		ISO 8528-2	ISO 8528-2
	Type PERKINS	1104C-44TG3	
	(optional)	1104C-44TG2	1104C-44TG2
	Rated net output	53 kW	61 kW
	rating type acc. ISO 3046-7	ICXN	ICXN
	production tolerance	± 5%	± 5%
	Coolant	water	water
	Combustion system	direct injection	direct injection
	Aspiration	turbo charged	turbo charged
	Number of cylinders	4	4
	Swept volume	4.41 l	4.41 l
	Speed governing	mechanical	
	(optional)	electronic	electronic
	Capacity of oil sump	8.5 l	8.5 l
	Capacity of cooling system	12.6 l	12.6 l

Power circuit

Electrical system	12 Vdc	12 Vdc
Circuit-breaker, 3ph.		
Number of poles	4	4
Thermal release I_t (thermal release is higher at 25°C)	100 A	100 A
Magnetic release I_m	3..5x I_n	3..5x I_n
Circuit-breaker, 3ph., lower voltage		
Number of poles (optional)	3	4
Thermal release I_t (thermal release is higher at 25°C)	152 A	175 A
Magnetic release I_m	3..5x I_n	3..5x I_n
Circuit-breaker, 1ph.		
Number of poles (optional)	3	4
Thermal release I_t (thermal release is higher at 25°C)	175 A	187.5 A
Magnetic release I_m	3..5x I_n	3..5x I_n
Fault current protection		
Residual current release I_{Dn}	0.030-30 A	0.030-30 A
Insulation resistance (optional)	10-100 kOhm	10-100 kOhm
Outlet sockets (optional)		
Following three socket configuration is possible:	i) domestic 2p + PE 16 A/230 V	
1. i + ii + iii + iv		
2. i + ii + iii + iv (2x)		
3. i + ii + iii + iv + v	ii) CEE form 3p + N + PE 16 A/400 V	
	iii) CEE form 3p + N + PE 32 A/400 V	
	iv) CEE form 3p + N + PE 63 A/400 V	

<i>Unit</i>	Dimensions (LxWxH)	v) CEE form 3p + N + PE 125 A/400 V	
	Weight net mass	2910 x 1100 x 1560 mm	2910 x 1100 x 1560 mm
	Weight wet mass	1585 kg	1585 kg
		1805 kg	1805 kg

Notes

- 1) Reference conditions for engine performance to ISO 3046-1.
- 2) See derating diagram or consult the factory for other conditions.
- 3) At reference conditions unless otherwise stated.
- 4) Rating definition (ISO 8528-1):
LTP: Limited Time Power is the maximum electrical power which a generating set is capable of delivering (at variable load), in the event of a utility power failure (for up to 500 hours per year of which a maximum of 300 hours is continuous running). No overload is permitted on these ratings. The alternator is peak continuous rated (as defined in ISO 8528-3) at 25°C.
PRP: Prime Power is the maximum power available during a variable power sequence, which may be run for an unlimited number of hours per year, between stated maintenance intervals and under the stated ambient conditions. A 10% overload is permitted for 1 hour in 12 hours. The permissible average power output during a 24h period shall not exceed the stated load factor of 80%.
- 5) Specific mass fuel used: 0.86 kg/l.

Derating

Height (m)	Temperature (°C)										
	0	5	10	15	20	25	30	35	40	45	50
0	100	100	100	100	100	100	100	98	97	86	76
500	100	100	100	100	100	100	99	98	97	86	76
1000	100	100	100	100	100	99	98	97	96	86	75
1500	97	97	97	97	97	97	97	96	95	85	73
2000	94	94	94	94	94	94	94	94	93	82	71
2500	88	88	88	88	88	88	88	88	88	77	67
3000	88	88	88	88	88	88	88	88	88	77	67
3500	82	82	82	82	82	82	82	82	82	72	62
4000	82	82	82	82	82	82	82	82	82	72	62

For use of generator outside these conditions, please contact Atlas Copco.

Technical specifications for QAS 80 units

Readings on gauges

<i>Gauge</i>	<i>Reading</i>	<i>Unit</i>
Ammeter L1-L3 (P1-P3)	Below max. rating	A
Voltmeter (P4)	Below max. rating	V

Settings of switches

<i>Switch</i>	<i>Function</i>	<i>Activates at</i>
Engine oil pressure	Shut down	0.5 bar
Engine coolant temperature	Shut down	103°C

Specifications of the engine/alternator/unit

		<i>50 Hz</i>	<i>60 Hz</i>
<i>Reference conditions 1) 4)</i>	Rated frequency	50 Hz	60 Hz
	Rated speed (optional)	1500 rpm	1800 rpm
	Generator service duty	PRP	PRP
	Absolute air inlet pressure	100 kPa	100 kPa
	Relative air humidity	30%	30%
	Air inlet temperature	25°C	25°C
<i>Limitations 2)</i>	Maximum ambient temperature	50°C	50°C
	Altitude capability	4000 m	4000 m
	Maximum relative air humidity	85%	85%
	Minimum starting temperature unaided	-18°C	-18°C
	Minimum starting temperature aided (optional)	-25°C	-25°C
<i>Performance data 2) 3) 5)</i>	Rated active power (PRP) 3ph	64 kW	72.8 kW
	Rated active power (PRP) 1ph (optional)	56.5 kW	62.5 kW
	Rated power factor (lagging) 3ph	0.8 cos ϕ	0.8 cos ϕ
	Rated power factor (lagging) 1ph (optional)	1 cos ϕ	1 cos ϕ

Application data

Rated PRP power 3ph	80 kVA	91 kVA
Rated PRP power 1ph (optional)	56.5 kVA	62.5 kVA
Rated voltage 3ph line to line	400 V	480 V
Rated voltage 3ph line to line lower voltage	230 V	240 V
Rated voltage 1ph (optional)	230 V	240 V
Rated current 3ph	115.5 A	109.5 A
Rated current 3ph lower voltage	200.8 A	218.9 A
Rated current 1ph (optional)	245.7 A	260.4 A
Performance class (acc.ISO 8528-5:1993)	G2	G2
Single step load acceptance (0-PRP)	90%	100%
Frequency droop (optional)	< 5%	< 5%
	isochronous	isochronous
Fuel consumption at no load (0%)	2.2 kg/h	3.0 kg/h
Fuel consumption at 50% load	7.9 kg/h	9.7 kg/h
Fuel consumption at 75% load	10.9 kg/h	13.6 kg/h
Fuel consumption at full load (100%)	14.5 kg/h	16.8 kg/h
Specific fuel consumption at full load (100%)	0.225 kg/kWh	0.232 kg/kWh
Fuel autonomy at full load with standard tank	13.7 h	11.7 h
Fuel autonomy at full load with standard tank and optional skid fueltank	32.4 h	27.8 h
Max. oil consumption at full load	21.9 g/h	25.7 g/h
Maximum sound power level (LWA) measured according to 2000/14/EC OND	92 dB(A)	95 dB(A)
Capacity of fuel tank	230 l	230 l
Capacity of optional skid fuel tank	545 l	545 l
Single step load acceptance	100%	100%
Mode of operation	PRP	PRP
Site	land use	land use
Operation	single	single
Start-up and control mode	manual/automatic	manual/automatic
Start-up time	unspecified	unspecified
Mobility/Config. acc. to ISO 8528-1:1993 (optional)	transportable/D mobile/E	transportable/D mobile/E

<i>Alternator 4)</i>	Mounting	fully resilient	fully resilient
	Climatic exposure	open air	open air
	Degree of protection (cubicle)	IP 54	IP 54
	Status of neutral (TT or NT)	earthed	earthed
	Status of neutral (IT) (optional)	insulated	-
	Standard	IEC34-1	IEC34-1
	Make	ISO 8528-3	ISO 8528-3
	Model	CUMMINS	CUMMINS
	Rated output, class H temp. rise	UCI224-G1	UCI224-G1
	rating type acc. ISO 8528-3	85 kVA	103.8 kVA
	Degree of protection	BR	BR
	Insulation stator class	IP 23	IP 23
	Insulation rotor class	H	H
Number of wires	H	H	
<i>Engine 4)</i>	Standard	12	12
	Type PERKINS	ISO 3046	ISO 3046
	Rated net output	ISO 8528-2	ISO 8528-2
	rating type acc. ISO 3046-7	1104C-44TAG1	1104C-44TAG1
	production tolerance	71 kW	80 kW
	Coolant	ICXN	ICXN
	Combustion system	± 5%	± 5%
	Aspiration	water	water
	Number of cylinders	direct injection	direct injection
	Swept volume	turbo-charged intercooled	turbo-charged intercooled
	Speed governing	4	4
	(optional)	4.41 l	4.41 l
	Capacity of oil sump	mechanical	mechanical
Capacity of cooling system	electronic	electronic	
Electrical system	8.5 l	8.5 l	
	12.6 l	12.6 l	
	12 Vdc	12 Vdc	

Power circuit

Circuit-breaker, 3ph.

Number of poles	4	4
Thermal release It (thermal release is higher at 25°C)	125 A	125 A
Magnetic release Im	3..5xIn	3..5xIn

Circuit-breaker, 3ph., lower voltage

Number of poles (optional)	3	4
Thermal release It (thermal release is higher at 25°C)	200 A	225 A
Magnetic release Im	3..5xIn	3..5xIn

Circuit-breaker, 1ph.

Number of poles (optional)	3	4
Thermal release It (thermal release is higher at 25°C)	250 A	250 A
Magnetic release Im	3..5xIn	3..5xIn

Fault current protection

Residual current release IDn	0.030-30 A	0.030-30 A
Insulation resistance (optional)	10-100 kOhm	10-100 kOhm

Outlet sockets (optional)

Following three socket configuration is possible:

1. i + ii + iii + iv
16 A/230 V
 2. i + ii + iii + iv (2x)
16 A/400 V
 3. i + ii + iii + iv + v
32 A/400 V
- ii) CEE form
3p + N + PE
16 A/400 V
- iii) CEE form
3p + N + PE
32 A/400 V
- iv) CEE form
3p + N + PE
63 A/400 V

<i>Unit</i>		v) CEE form 3p + N + PE 125 A/400 V	
	Dimensions (LxWxH)	2910 x 1100 x 1560 mm	2910 x 1100 x 1560 mm
	Weight net mass	1705 kg	1705 kg
	Weight wet mass	1925 kg	1925 kg

Notes

- 1) Reference conditions for engine performance to ISO 3046-1.
- 2) See derating diagram or consult the factory for other conditions.
- 3) At reference conditions unless otherwise stated.
- 4) Rating definition (ISO 8528-1):
LTP: Limited Time Power is the maximum electrical power which a generating set is capable of delivering (at variable load), in the event of a utility power failure (for up to 500 hours per year of which a maximum of 300 hours is continuous running). No overload is permitted on these ratings. The alternator is peak continuous rated (as defined in ISO 8528-3) at 25°C.
PRP: Prime Power is the maximum power available during a variable power sequence, which may be run for an unlimited number of hours per year, between stated maintenance intervals and under the stated ambient conditions. A 10% overload is permitted for 1 hour in 12 hours. The permissible average power output during a 24h period shall not exceed the stated load factor of 80%.
- 5) Specific mass fuel used: 0.86 kg/l.

Derating

Height (m)	Temperature (°C)										
	0	5	10	15	20	25	30	35	40	45	50
0	100	100	100	100	100	100	99	98	97	86	76
500	100	100	100	100	100	100	99	98	97	86	76
1000	100	100	100	100	100	99	98	97	96	85	75
1500	100	100	100	100	99	98	96	96	95	85	74
2000	99	99	99	98	97	96	95	94	93	83	74
2500	92	92	92	92	92	92	92	92	92	81	69
3000	92	92	92	92	92	92	91	90	89	79	69
3500	86	86	86	86	86	86	86	86	86	75	65
4000	86	86	86	86	86	86	85	84	83	74	65

For use of generator outside these conditions, please contact Atlas Copco.

Technical specifications for QAS 100 units

Readings on gauges

<i>Gauge</i>	<i>Reading</i>	<i>Unit</i>
Ammeter L1-L3 (P1-P3)	Below max. rating	A
Voltmeter (P4)	Below max. rating	V

Settings of switches

<i>Switch</i>	<i>Function</i>	<i>Activates at</i>
Engine oil pressure	Shut down	0.5 bar
Engine coolant temperature	Shut down	103°C

Specifications of the engine/alternator/unit

		<i>50 Hz</i>	<i>60 Hz</i>
<i>Reference conditions 1) 4)</i>	Rated frequency	50 Hz	60 Hz
	Rated speed (optional)	1500 rpm	1800 rpm
	Generator service duty	PRP	PRP
	Absolute air inlet pressure	100 kPa	100 kPa
	Relative air humidity	30%	30%
	Air inlet temperature	25°C	25°C
<i>Limitations 2)</i>	Maximum ambient temperature	50°C	50°C
	Altitude capability	4000 m	4000 m
	Maximum relative air humidity	85%	85%
	Minimum starting temperature unaided	-18°C	-18°C
	Minimum starting temperature aided (optional)	-25°C	-25°C
<i>Performance data 2) 3) 5)</i>	Rated active power (PRP) 3ph	80 kW	92 kW
	Rated active power (PRP) 1ph (optional)	60 kW	67.5 kW
	Rated power factor (lagging) 3ph	0.8 cos ϕ	0.8 cos ϕ
	Rated power factor (lagging) 1ph (optional)	1 cos ϕ	1 cos ϕ

Rated PRP power 3ph	100 kVA	115 kVA
Rated PRP power 1ph (optional)	60 kVA	67.5 kVA
Rated voltage 3ph line to line	400 V	480 V
Rated voltage 3ph line to line lower voltage	230 V	240 V
Rated voltage 1ph (optional)	230 V	240 V
Rated current 3ph	144.3 A	138.3 A
Rated current 3ph lower voltage	251.0 A	276.6 A
Rated current 1ph (optional)	260.9 A	281.3 A
Performance class (acc.ISO 8528-5:1993)	G2	G2
Frequency droop (optional)	< 5%	< 5%
	isochronous	isochronous
Fuel consumption at no load (0%)	2.2 kg/h	2.8 kg/h
Fuel consumption at 50% load	10.2 kg/h	12.6 kg/h
Fuel consumption at 75% load	14.2 kg/h	17.5 kg/h
Fuel consumption at full load (100%)	18.8 kg/h	23.1 kg/h
Specific fuel consumption at full load (100%)	0.236 kg/kWh	0.255 kg/kWh
Fuel autonomy at full load with standard tank	10.5 h	8.6 h
Fuel autonomy at full load with standard tank and optional skid fuel tank	25.0 h	20.3 h
Max. oil consumption at full load	28.2 g/h	34.7 g/h
Maximum sound power level (LWA) measured according to 2000/14/EC OND	92 dB(A)	95 dB(A)
Capacity of fuel tank	230 l	230 l
Capacity of optional skid fuel tank	545 l	545 l
Single step load acceptance	80%	90%
<i>Application data</i>		
Mode of operation	PRP	PRP
Site	land use	land use
Operation	single	single
Start-up and control mode	manual/automatic	manual/automatic
Start-up time	unspecified	unspecified
Mobility/Config. acc. to ISO 8528-1:1993 (optional)	transportable/D mobile/E	transportable/D mobile/E
Mounting	fully resilient	fully resilient

	Climatic exposure	open air	open air
	Degree of protection (cubicle)	IP 54	IP 54
	Status of neutral (TT or NT)	earthed	earthed
	Status of neutral (IT)	insulated	-
<i>Alternator 4)</i>	Standard	IEC34-1	IEC34-1
		ISO 8528-3	ISO 8528-3
	Make	CUMMINS	CUMMINS
	Model	UCI274-C1	UCI274-C1
	Rated output, class H temp. rise	100 kVA	125 kVA
	rating type acc. ISO 8528-3	BR	BR
	Degree of protection	IP 23	IP 23
	Insulation stator class	H	H
	Insulation rotor class	H	H
	Number of wires	12	12
<i>Engine 4)</i>	Standard	ISO 3046	ISO 3046
		ISO 8528-2	ISO 8528-2
	Type PERKINS	1104C-44TAG2	1104C-44TAG2
	Rated net output	89 kW	100 kW
	rating type acc. ISO 3046-7	ICXN	ICXN
	production tolerance	± 5%	± 5%
	Coolant	water	water
	Combustion system	direct injection	direct injection
	Aspiration	turbo-charged intercooled	turbo-charged intercooled
	Number of cylinders	4	4
	Swept volume	4.41 l	4.41 l
	Speed governing	electronic	electronic
	Capacity of oil sump	8.5 l	8.5 l
	Capacity of cooling system	12.6 l	12.6 l
	Electrical system	12 Vdc	12 Vdc

Power circuit

Circuit-breaker, 3ph.

Number of poles	4	4
Thermal release It (thermal release is higher at 25°C)	144 A	144 A
Magnetic release Im	3..5xIn	3..5xIn

Circuit-breaker, 3ph., lower voltage

Number of poles (optional)	3	4
Thermal release It (thermal release is higher at 25°C)	252 A	280 A
Magnetic release Im	3..5xIn	3..5xIn

Circuit-breaker, 1ph.

Number of poles (optional)	3	4
Thermal release It (thermal release is higher at 25°C)	280 A	280 A
Magnetic release Im	3..5xIn	3..5xIn

Fault current protection

Residual current release IDn	0.030-30 A	0.030-30 A
Insulation resistance (optional)	10-100 kOhm	10-100 kOhm

Outlet sockets (optional)

Following three socket configuration is possible:

1. i + ii + iii + iv
16 A/230 V
 2. i + ii + iii + iv (2x)
16 A/400 V
 3. i + ii + iii + iv + v
32 A/400 V
- ii) CEE form
3p + N + PE
16 A/400 V
- iii) CEE form
3p + N + PE
32 A/400 V
- iv) CEE form
3p + N + PE
63 A/400 V

<i>Unit</i>		v) CEE form 3p + N + PE 125 A/400 V	
	Dimensions (LxWxH)	2910 x 1100 x 1560 mm	2910 x 1100 x 1560 mm
	Weight net mass	1730 kg	1730 kg
	Weight wet mass	1950 kg	1950 kg

Notes

- 1) Reference conditions for engine performance to ISO 3046-1.
- 2) See derating diagram or consult the factory for other conditions.
- 3) At reference conditions unless otherwise stated.
- 4) Rating definition (ISO 8528-1):
LTP: Limited Time Power is the maximum electrical power which a generating set is capable of delivering (at variable load), in the event of a utility power failure (for up to 500 hours per year of which a maximum of 300 hours is continuous running). No overload is permitted on these ratings. The alternator is peak continuous rated (as defined in ISO 8528-3) at 25°C.
PRP: Prime Power is the maximum power available during a variable power sequence, which may be run for an unlimited number of hours per year, between stated maintenance intervals and under the stated ambient conditions. A 10% overload is permitted for 1 hour in 12 hours. The permissible average power output during a 24h period shall not exceed the stated load factor of 80%.
- 5) Specific mass fuel used: 0.86 kg/l.

Derating

Height (m)	Temperature (°C)										
	0	5	10	15	20	25	30	35	40	45	50
0	100	100	100	100	100	100	100	98	97	87	75
500	100	100	100	100	100	100	99	98	97	87	75
1000	100	100	100	100	100	99	98	97	96	86	75
1500	97	97	97	97	97	97	97	96	95	85	73
2000	94	94	94	94	94	94	94	94	93	82	71
2500	88	88	88	88	88	88	88	88	88	77	66
3000	88	88	88	88	88	88	88	88	88	77	66
3500	82	82	82	82	82	82	82	82	82	72	62
4000	82	82	82	82	82	82	82	82	82	72	62

For use of generator outside these conditions, please contact Atlas Copco.

Conversion list of SI units into British units

1 bar	=	14.504 psi
1 g	=	0.035 oz
1 kg	=	2.205 lb
1 km/h	=	0.621 mile/h
1 kW	=	1.341 hp (UK and US)
1 l	=	0.264 US gal
1 l	=	0.220 imp gal (UK)
1 l	=	0.035 cu.ft
1 m	=	3.281 ft
1 mm	=	0.039 in
1 m ³ /min	=	35.315 cfm
1 mbar	=	0.401 in wc
1 N	=	0.225 lbf
1 Nm	=	0.738 lbf.ft
t_{F}	=	$32 + (1.8 \times t_{\text{C}})$
t_{C}	=	$(t_{\text{F}} - 32)/1.8$

A temperature difference of 1°C = a temperature difference of 1.8°F.

Dataplate

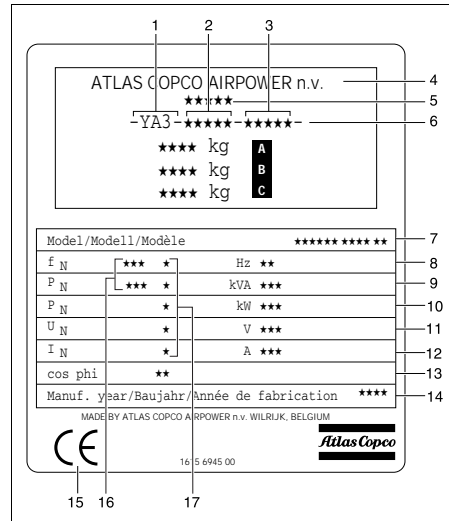

- A Maximum permitted total weight of the vehicle
- B Maximum permitted front axle load
- C Maximum permitted load on towing eye
- 1 Company code
- 2 Product code
- 3 Unit serial number
- 4 Name of manufacturer
- 5 EEC or national type approved number
- 6 Vehicle identification number
- 7 Model number
- 8 Frequency
- 9 Apparant power - PRP
- 10 Active power - PRP
- 11 Nominal rated voltage
- 12 Nominal rated current
- 13 Power factor
- 14 Manufacturing year
- 15 EEC mark in accordance witt Machine Directive 89/392E
- 16 Mode of operation
- 17 Winding connections

Disposal

General

When developing products and services, Atlas Copco tries to understand, address, and minimize the negative environmental effects that the products and services may have, when being manufactured, distributed, and used, as well as at their disposal.

Recycling and disposal policy are part of the development of all Atlas Copco products. Atlas Copco company standards determine strict requirements.

Selecting materials the substantial recyclability, the disassembly possibilities and the separability of materials and assemblies are considered as well as the environmental perils and dangers to health during the recycling and disposal of the unavoidable rates of not recyclable materials.

Your Atlas Copco generator consists for the most part of metallic materials, that can be remelted in steelworks and smelting works and that is therefore almost infinite recyclable. The plastic used is labelled; sorting and fractioning of the materials for recycling in the future is foreseen.



This concept can only succeed with your help. Support us by disposing professionally. By assuring a correct disposal of the product you help to prevent possible negative consequences for environment and health, that can occur with an inappropriate waste handling.

Recycling and re-usage of material helps to preserve natural resources.

Disposal of materials

Dispose contaminated substances and material separately, according to local applicable environmental legislations.

Before dismantling a machine at the end of its operating lifetime drain all fluids and dispose of according the applicable local disposal regulations.

Remove the batteries. Do not throw batteries into the fire (explosion risk) or into the residual waste. Separate the machine into metal, electronics, wiring, hoses, insulation and plastic parts.

Dispose all components according to the applicable disposal regulations.

Remove spilled fluid mechanically; pick up the rest with absorbing agent (for example sand, sawdust) and dispose it according the applicable local disposal regulations. Do not drain into the sewage system or surface water.

Circuit diagrams

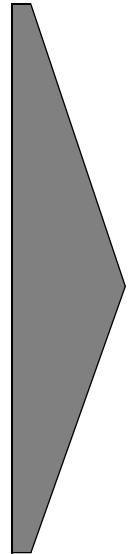

9822 0996 00/01 A
Applicable for QAS 60-80-100 Pd - Power circuit

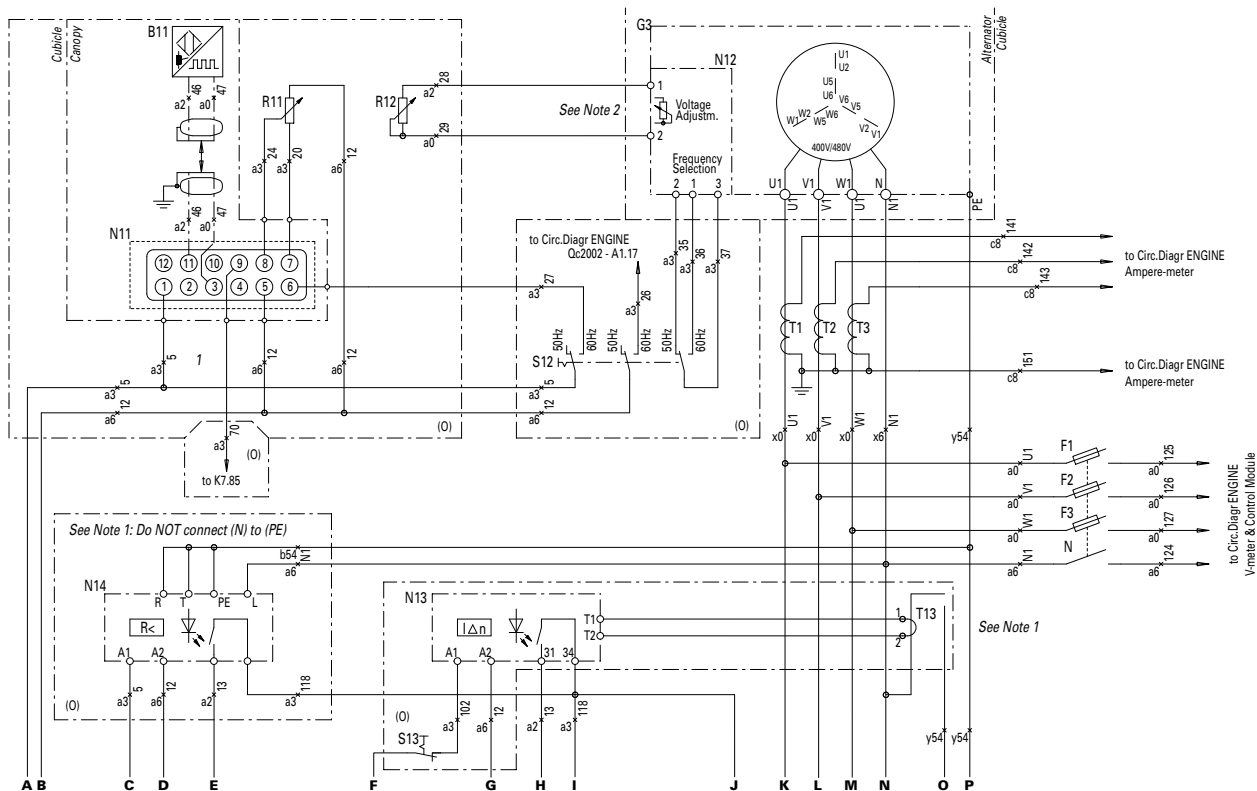

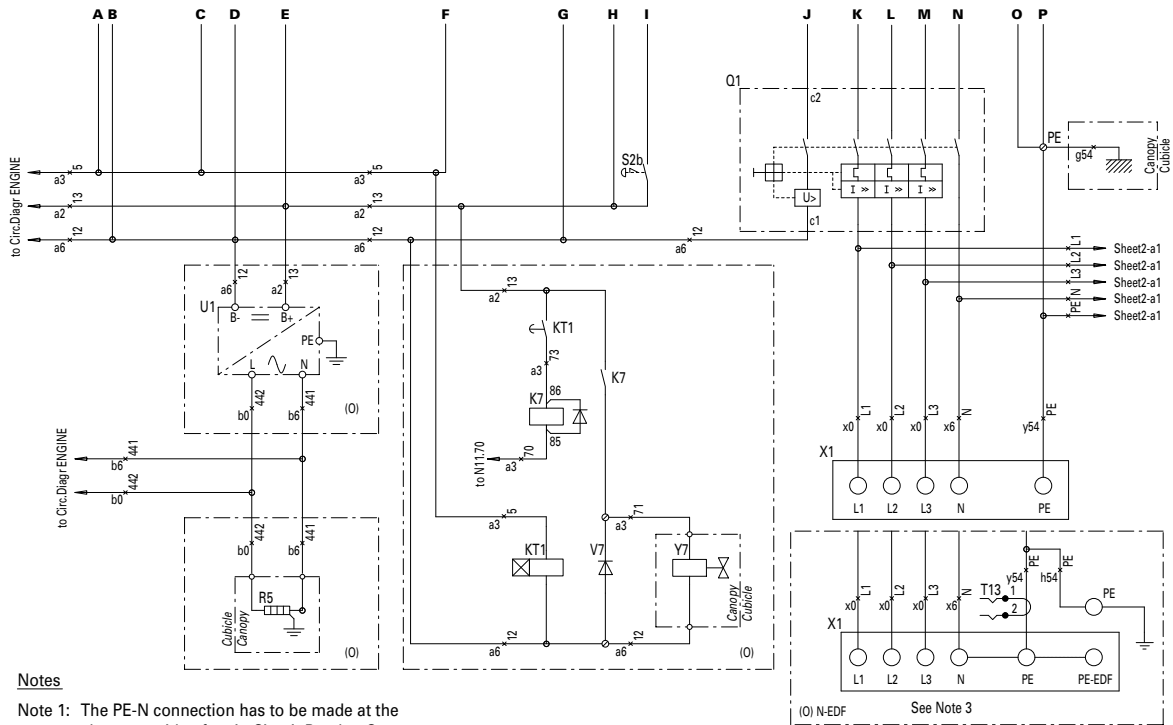

- Legend**
- Wire size :**
- a = 1 mm²
 - b = 1.5 mm²
 - c = 2.5 mm²
 - d = 4 mm²
 - e = 6 mm²
 - f = 10 mm²
 - g = 16 mm²
 - h = 25 mm²
 - i = 35 mm²
 - j = 50 mm²
 - k = 70 mm²
 - l = 95 mm²
 - lx = 95 mm² EPR-CSP (BS6195-4C)
 - bx = 1.5 mm² NSGA0eU
- Colour code :**
- 0 = black
 - 1 = brown
 - 2 = red
 - 3 = orange
 - 4 = yellow
 - 5 = green
 - 6 = blue
 - 7 = purple
 - 8 = grey
 - 9 = white
 - 54 = green/yel.

Notes

- Note 1: The PE-N connection has to be made at the alternator-side of main Circuit Breaker Q1.
- Note 2: Link N12.1 to N12.2 on gen-sets without Electronic Speed Regulation (= no potentiometer R12).
- Note 3: With "TB EDF", do NOT connect (N) to (PE) at Q1. T13 is to be mounted on the (PE)-conductor, instead of on the PE-N connection in the cubicle.

	QAS	T1	Q1	Wire Size x	Wire Size y
 400V/480V	60	100/5A	100A	35mm ²	16mm ²
	80	150/5A	125A	50mm ²	25mm ²
	100	150/5A	144A	50mm ²	25mm ²

B11	Speed sensor MPU (O)
F1-F3	Fuses 4 A
G3	Alternator
K7	Auxiliary relay for Y7 (O)
N11	Speed controller (O)
N12	Automatic voltage regulator
N13	Earth leakage relay (O)
N14	IT-relay (O)
Q1	Circuit breaker
R5	Coolant heater (O)
R11	Speed adjustment 5K (O)
R12	Voltage adjustment 1K (O)
S2b	Emergency stop (S2a: see Engine circuit)
S12	50/60 Hz-switch (O)
S13	E.L.R. disable switch (O)
T1-T3	Current transformers
T13	Torus earth leakage (O)
U1	Battery charger (O)
V7	Free-wheeling diode Y7
X1	Terminal board
Y7	Air inlet shutdown valve (O)
(O)	Optional equipment

9822 0996 00/01 B
Applicable for QAS 60-80-100 Pd - Power Circuit

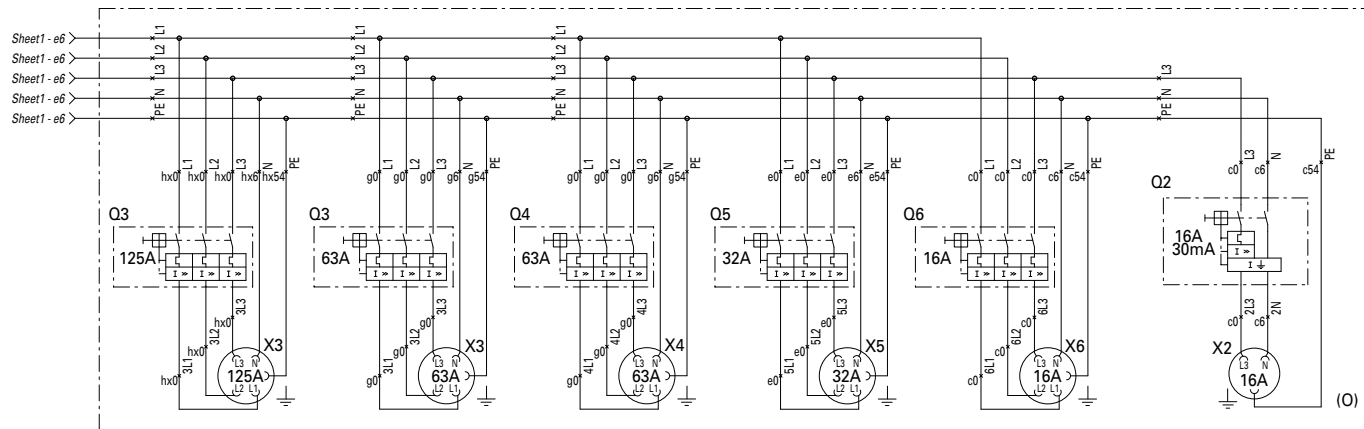

Legend

Wire size :

aa = 0.5 mm ²	0 = black
a = 1 mm ²	1 = brown
b = 1.5 mm ²	2 = red
c = 2.5 mm ²	3 = orange
d = 4 mm ²	4 = yellow
e = 6 mm ²	5 = green
f = 10 mm ²	6 = blue
g = 16 mm ²	7 = purple
h = 25 mm ²	8 = grey
i = 35 mm ²	9 = white
j = 50 mm ²	54 = green/yellow
k = 70 mm ²	
l = 95 mm ²	
n = 150 mm ²	
hx = 25 mm ² EPR-CSP to BS6195 4C	
ix = 35 mm ² EPR-CSP to BS6195 4C	
kx = 70 mm ² EPR-CSP to BS6195 4C	
lx = 95 mm ² EPR-CSP to BS6195 4C	
mx = 120 mm ² EPR-CSP to BS6195 4C	
nx = 150 mm ² EPR-CSP to BS6195 4C	

Q2	Circuit breaker 16 A/30 mA
Q3	Circuit breaker 63 A or 125 A
Q4	Circuit breaker 63 A
Q5	Circuit breaker 32 A
Q6	Circuit breaker 16 A
X2	Outlet socket 16 A 1ph
X3	Outlet socket 63 A or 125 A
X4	Outlet socket 63 A
X5	Outlet socket 32 A
X6	Outlet socket 16 A
(O)	Optional equipment

9822 0996 01/01

Applicable for QAS 60-80-100 Pd - Power circuit - Dual voltage, 50 Hz, 1 phase

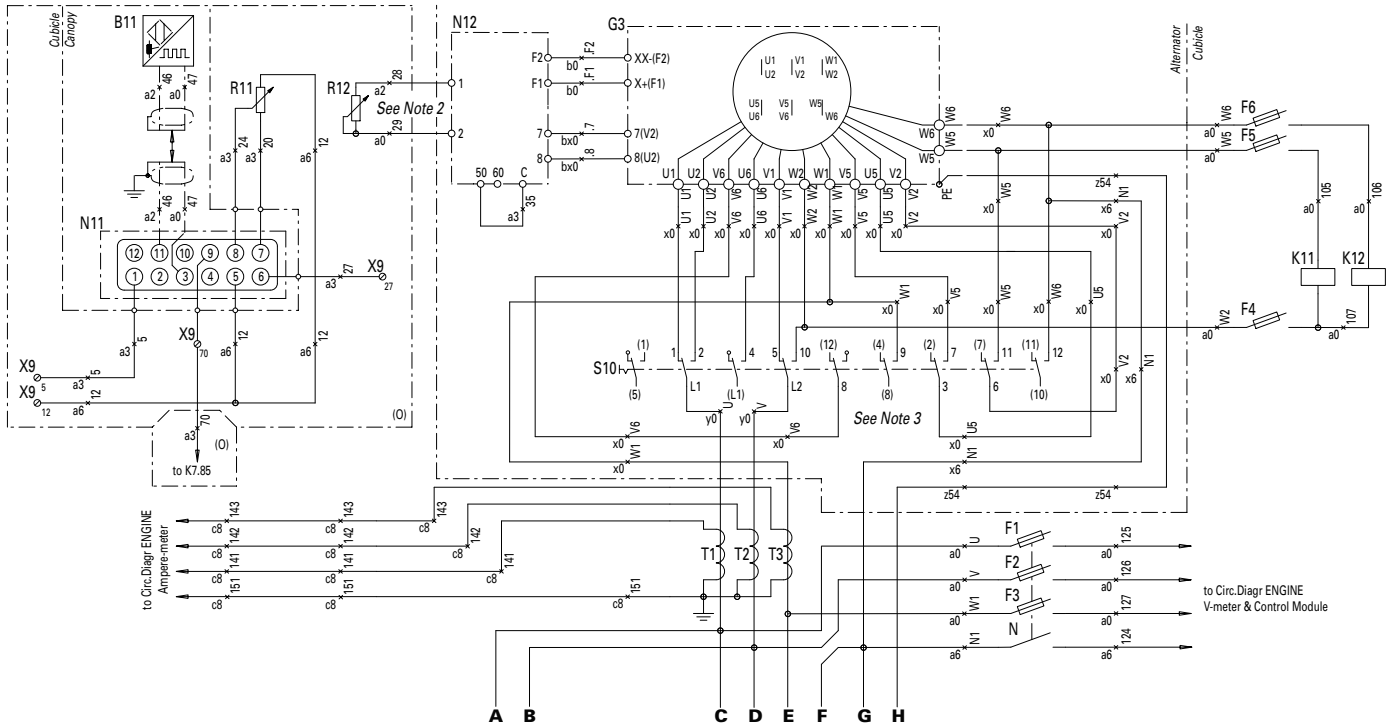

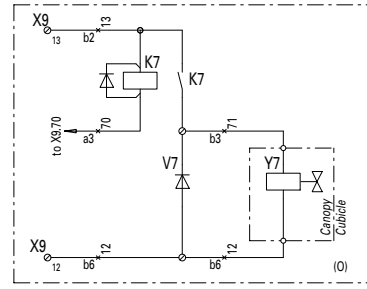
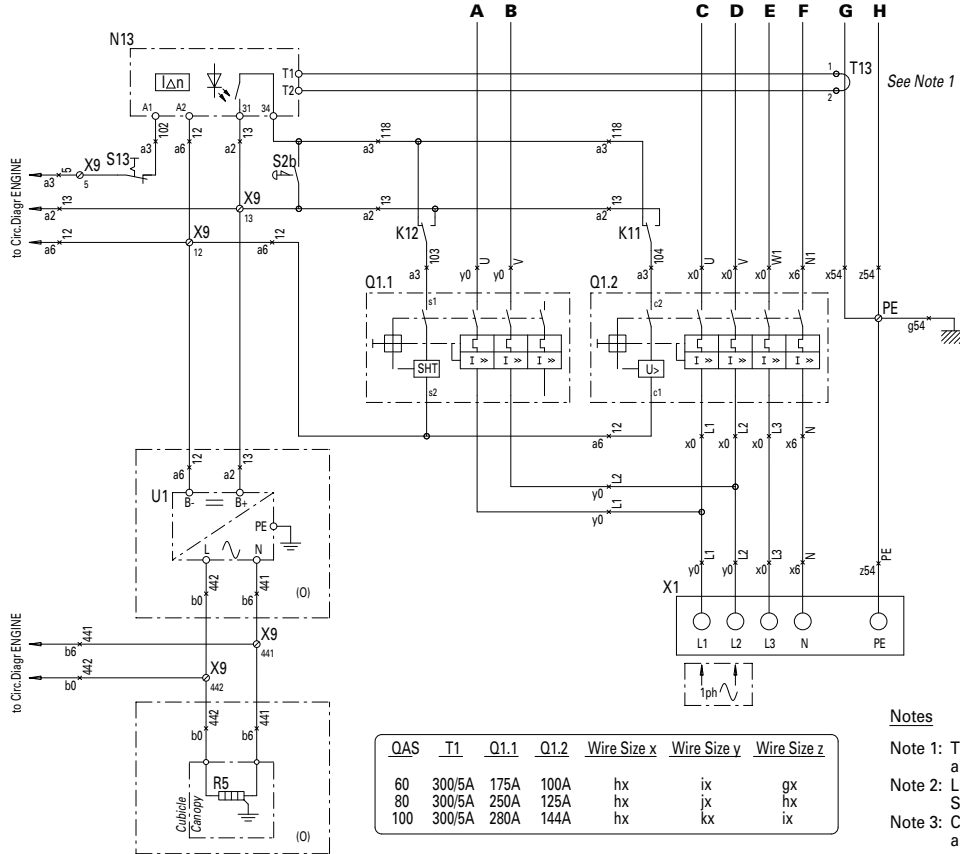

See Note 1

Legend

- Wire size :**
- a = 1 mm²
 - b = 1.5 mm²
 - c = 2.5 mm²
 - d = 4 mm²
 - e = 6 mm²
 - f = 10 mm²
 - g = 16 mm²
 - h = 25 mm²
 - i = 35 mm²
 - j = 50 mm²
 - k = 70 mm²
 - l = 95 mm²
 - lx = 95 mm² EPR-CSP (BS6195-4C)
 - bx = 1.5 mm² NSGAFOeU
 - gx = 16 mm² EPR-CSP to BS6195 4C
 - hx = 25 mm² ERP-CSP to BS6195 4C
 - ix = 35 mm² ERP-CSP to BS6195 4C
 - jx = 50 mm² ERP-CSP to BS6195 4C
 - kx = 70 mm² ERP-CSP to BS6195 4C
- Colour code :**
- 0 = black
 - 1 = brown
 - 2 = red
 - 3 = orange
 - 4 = yellow
 - 5 = green
 - 6 = blue
 - 7 = purple
 - 8 = grey
 - 9 = white
 - 54 = green/yel.

Notes

- Note 1: The PE-N connection has to be made at the alternator-side of main Circuit Breaker Q1.
- Note 2: Link N12.1 to N12.2 on gen-sets without Electronic Speed Regulation (= no potentiometer R12).
- Note 3: Contacts on S10 indicated between brackets, e.g.(6) aren't to be connected. They are linked internally.

QAS	T1	Q1.1	Q1.2	Wire Size x	Wire Size y	Wire Size z
60	300/5A	175A	100A	hx	ix	gx
80	300/5A	250A	125A	hx	jx	hx
100	300/5A	280A	144A	hx	kx	ix

B11	Speed sensor MPU (O)
F1-F6	Fuses 4 A
G3	Alternator
K7	Auxiliary relay for Y7 (O)
K11	Aux. relay select 230Vzz (lower voltage)
K12	Aux. relay select 400Vy (higher voltage)
N11	Speed controller (O)
N12	Automatic voltage regulator
N13	Earth leakage relay (O)
Q1.1	Circuit breaker 230Vzz (lower voltage)
Q1.2	Circuit breaker 400Vy (higher voltage)
R5	Coolant heater (O)
R11	Speed adjustment 5K (O)
R12	Voltage adjustment 1K (O)
S2b	Emergency stop (S2a: see Engine circuit)
S10	Voltage selector switch
S13	E.L.R. disable switch (O)
T1-T3	Current transformers
T13	Torus earth leakage (O)
U1	Battery charger (O)
V7	Free-wheeling diode Y7
X1	Terminal board
X9	Terminal strip
Y7	Air inlet shutdown valve (O)
(O)	Optional equipment

9822 0996 02/01

Applicable for QAS 60-80-100 Pd - Power circuit - Dual voltage, 50 Hz

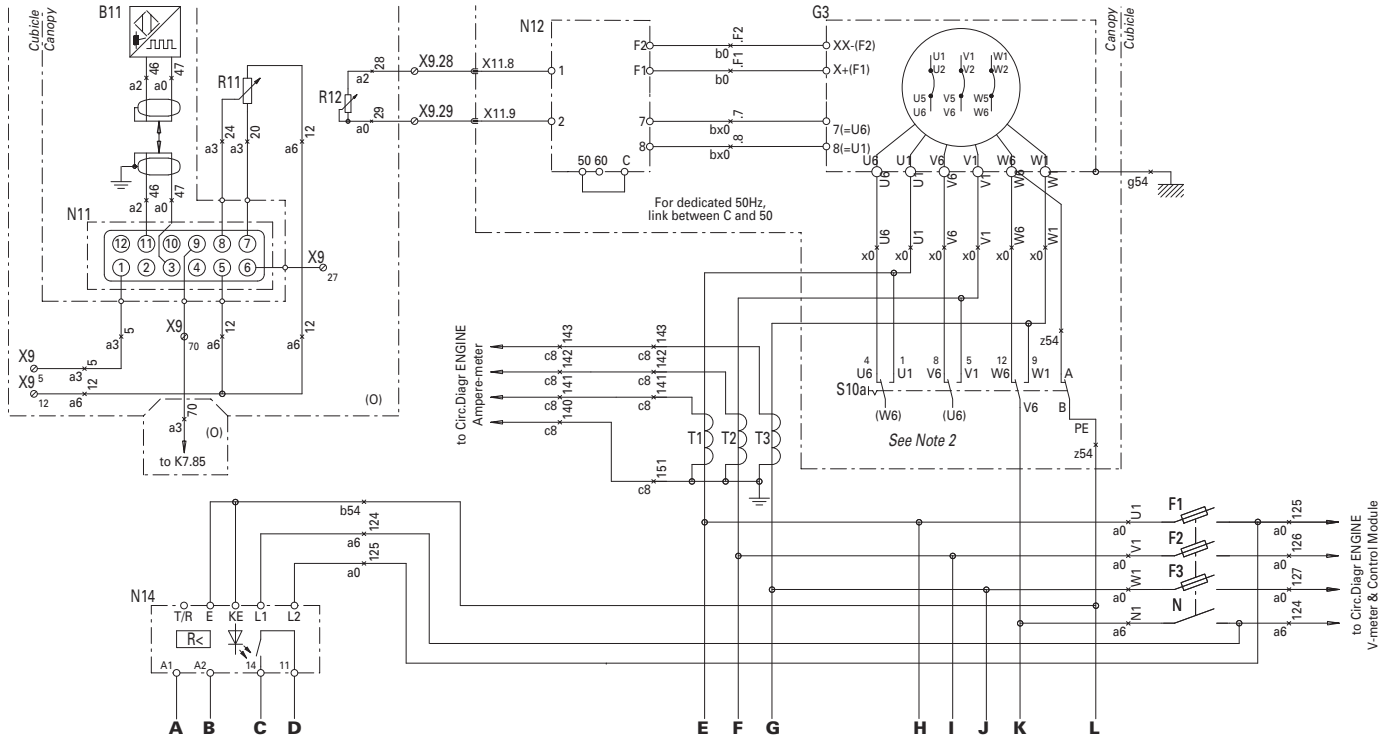

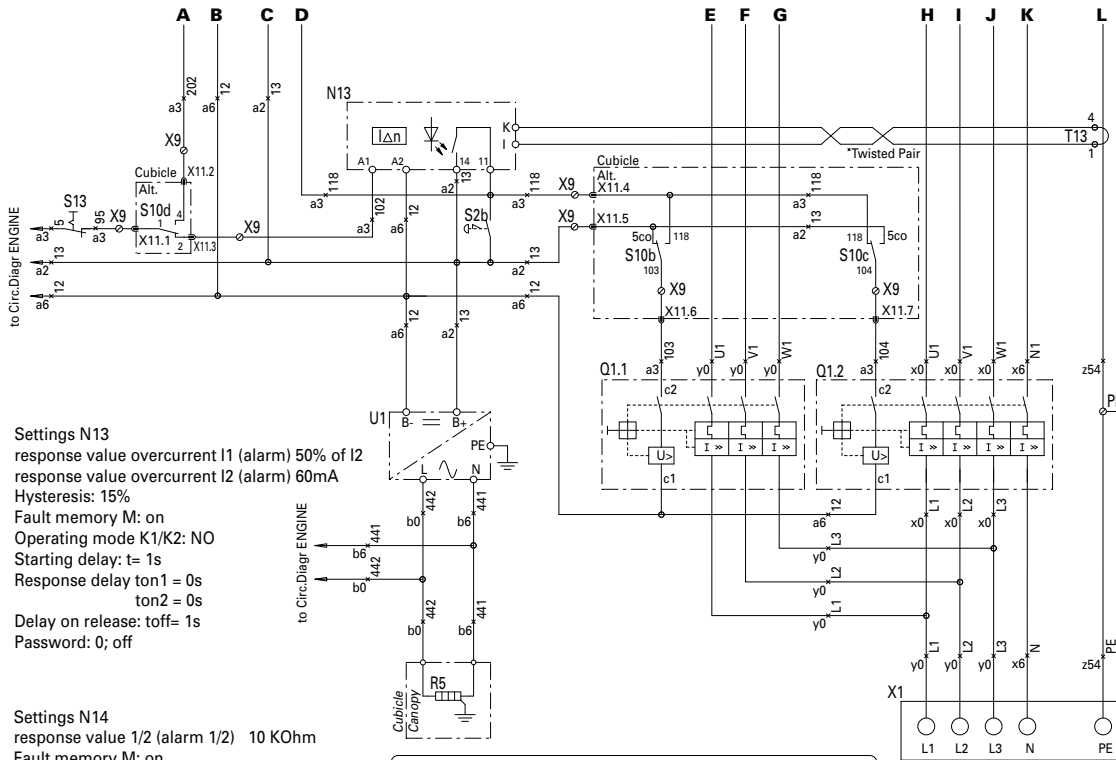

Settings N13

response value overcurrent I1 (alarm) 50% of I2
 response value overcurrent I2 (alarm) 60mA
 Hysteresis: 15%
 Fault memory M: on
 Operating mode K1/K2: NO
 Starting delay: t= 1s
 Response delay ton1 = 0s
 ton2 = 0s
 Delay on release: toff= 1s
 Password: 0; off

Settings N14

response value 1/2 (alarm 1/2) 10 KOhm
 Fault memory M: on
 Operating mode K1/K2: NO
 Starting delay: t= 1s
 Response delay ton = 0s
 Password: off

OAS	T1	Q1.1	Q1.2	Wire Size x	Wire Size y	Wire Size z
60	150/5A	152A	100A	hx	hx	gx
80	300/5A	200A	125A	hx	ix	hx
100	300/5A	250A	144A	hx	jx	hx

Legend

Wire size :	Colour code :
aa = 0.5 mm ²	0 = black
a = 1 mm ²	1 = brown
b = 1.5 mm ²	2 = red
c = 2.5 mm ²	3 = orange
d = 4 mm ²	4 = yellow
e = 6 mm ²	5 = green
f = 10 mm ²	6 = blue
g = 16 mm ²	7 = purple
h = 25 mm ²	8 = grey
i = 35 mm ²	9 = white
j = 50 mm ²	54 = green/yel.
k = 70 mm ²	
bx = 1.5 mm ² NSGAFOeU	
gx = 16 mm ² EPR-CSP to BS6195 4C	
hx = 25 mm ² EPR-CSP to BS6195 4C	
ix = 35 mm ² EPR-CSP to BS6195 4C	
jx = 50 mm ² EPR-CSP to BS6195 4C	

Notes

- Note 1: The PE-N connection has to be made at the alternator-side. Inspection of switch/connection required before each start-up.
- Note 2: Contacts on S10 indicated between brackets, e.g.(U6) aren't to be connected. They are linked internally.

B11	Speed sensor MPU (O)
F1-F3	Fuses 4 A
G3	Alternator
N11	Speed controller (O)
N12	Automatic voltage regulator
N13	Earth leakage relay (O)
N14	IT relay
Q1.1	Circuit breaker 230Vd (lower voltage)
Q1.2	Circuit breaker 400Vy (higher voltage)
R5	Coolant heater (O)
R11	Speed adjustment 5K (O)
R12	Voltage adjustment 1K (O)
S2b	Emergency stop (S2a: see Engine circuit)
S10a-d	Voltage selector switch
S13	E.L.R. disable switch (O)
T3	Current transformers
T13	Torus earth leakage (O)
U1	Battery charger (O)
V7	Free-wheeling diode Y7
X1	Terminal board
X9	Terminal strip
(O)	Optional equipment

9822 0996 05/01
Applicable for QAS 60-80-100 Pd - Engine Circuit Qc1002™

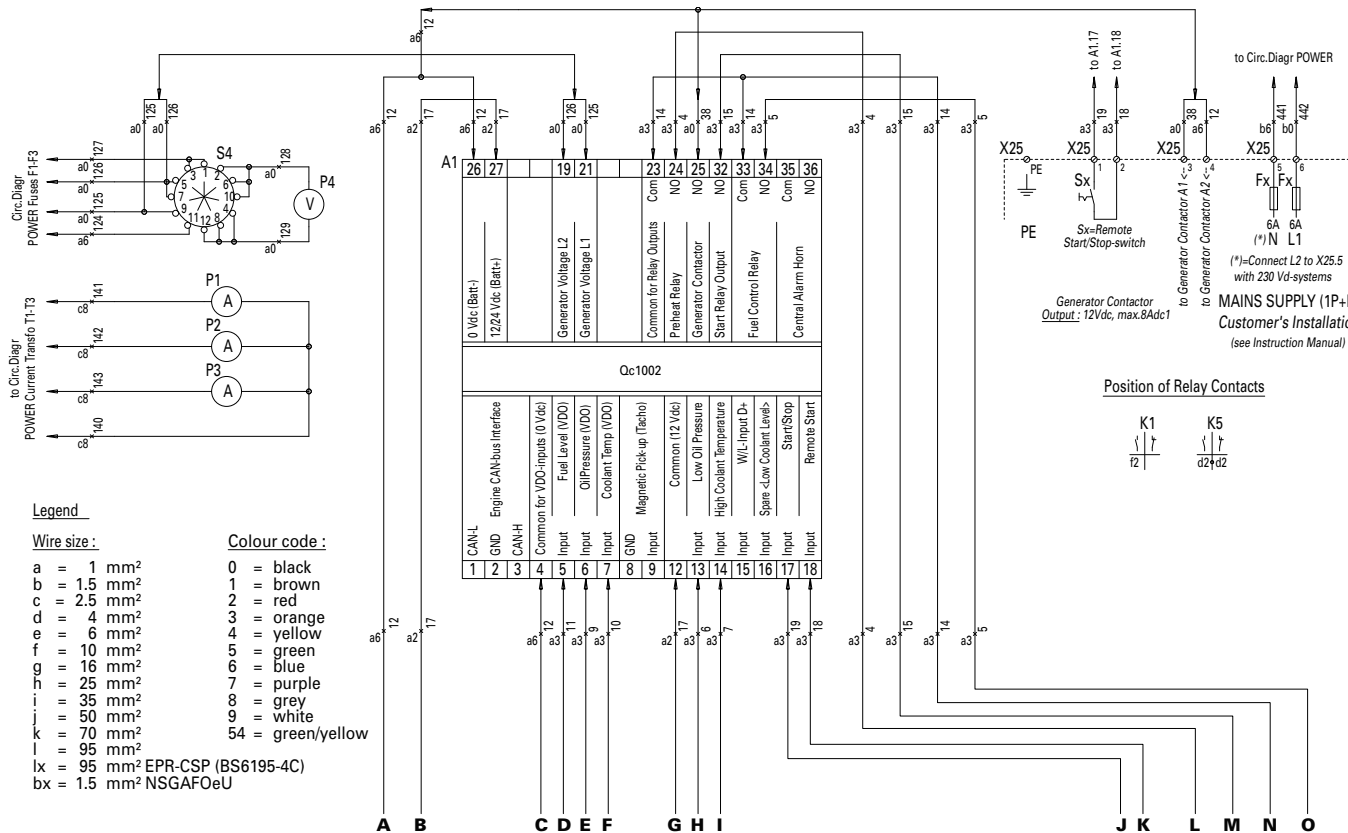

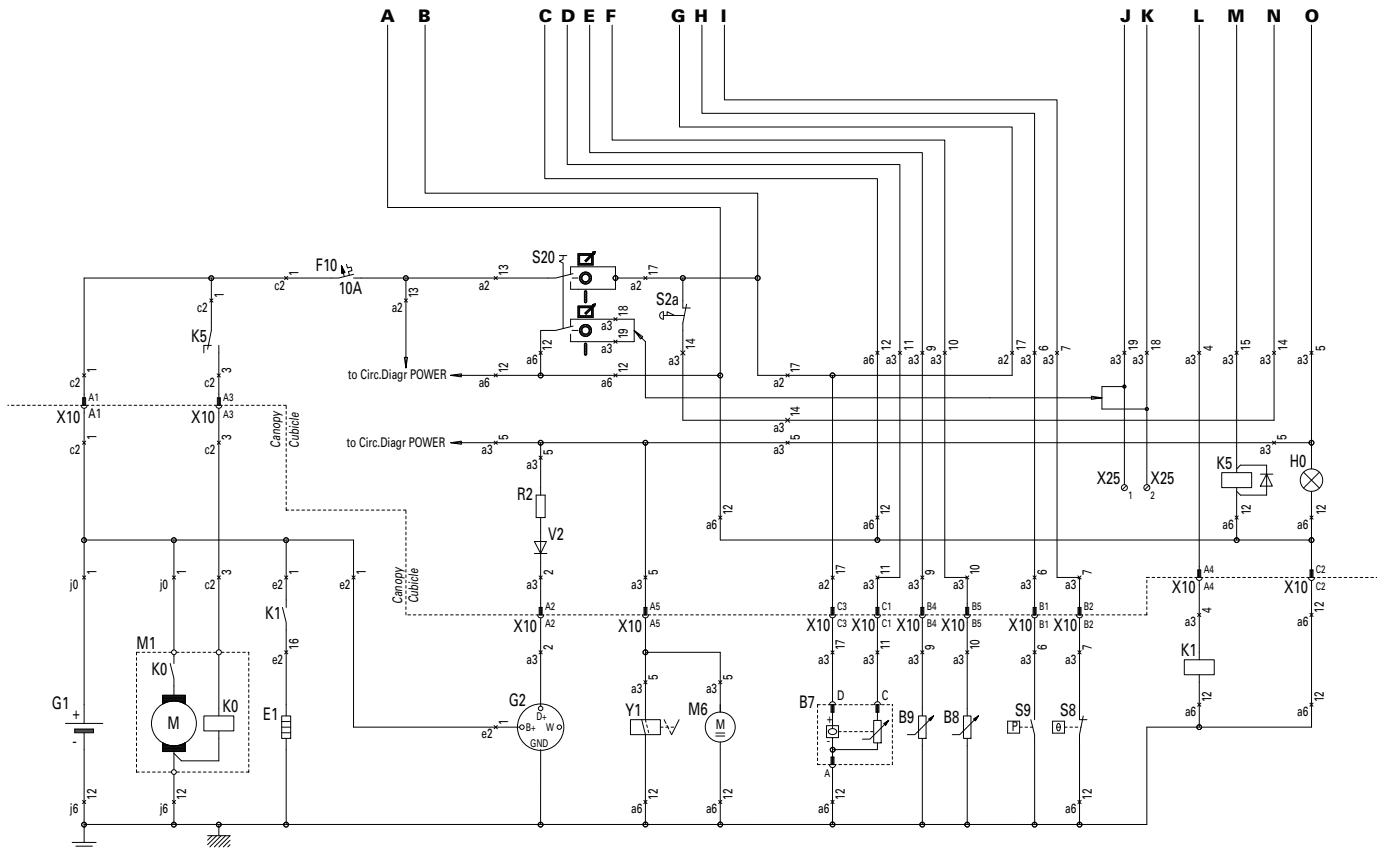

A1	Generator control unit (set A1 in UNIT-type 2)
B7	Fuel level sensor
B8	Coolant temperature sensor
B9	Oil pressure sensor
E1	Preheat resistor
F10	Fuse 10A DC
G1	Battery 12 Vdc
G2	Charging alternator
H0	Panel light
K0	Starter solenoid
K1	Preheat relay
K5	Starter relay
M1	Starter motor
M6	Fuel feed pump
P1-P3	A-meter
P4	V-meter
R2	Excitation resistor 47ohm
S2a	Emergency stop (S2b: see Power circuit)
S4	V-meter change-over switch
S8	High coolant temperature switch
S9	Low oil pressure switch
S20	ON/OFF/REMOTE-switch
V2	Excitation diode
X10	Connector wire harness
X25	Customer's terminal strip
Y1	Fuel stop solenoid

9822 0996 06/01
Applicable for QAS 60-80-100 Pd - Engine Circuit Qc2002™

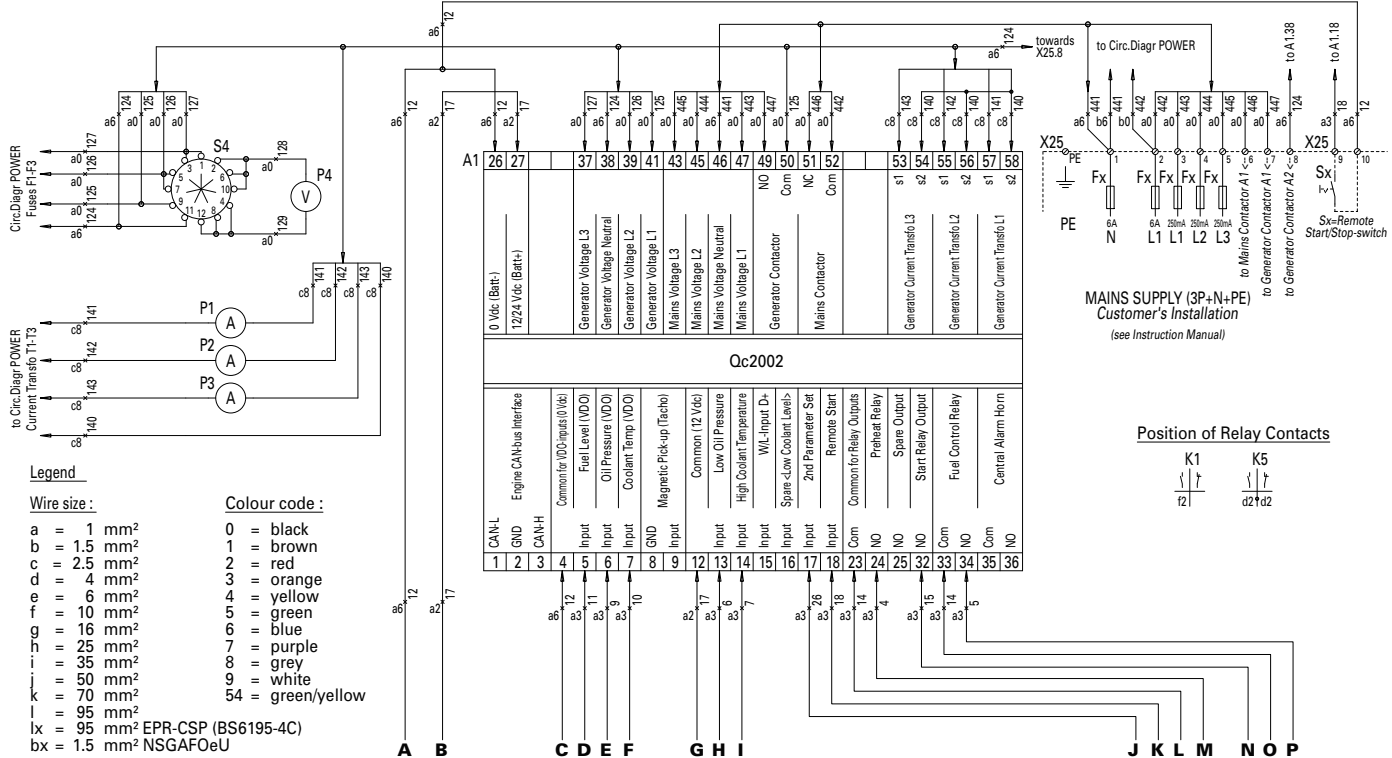

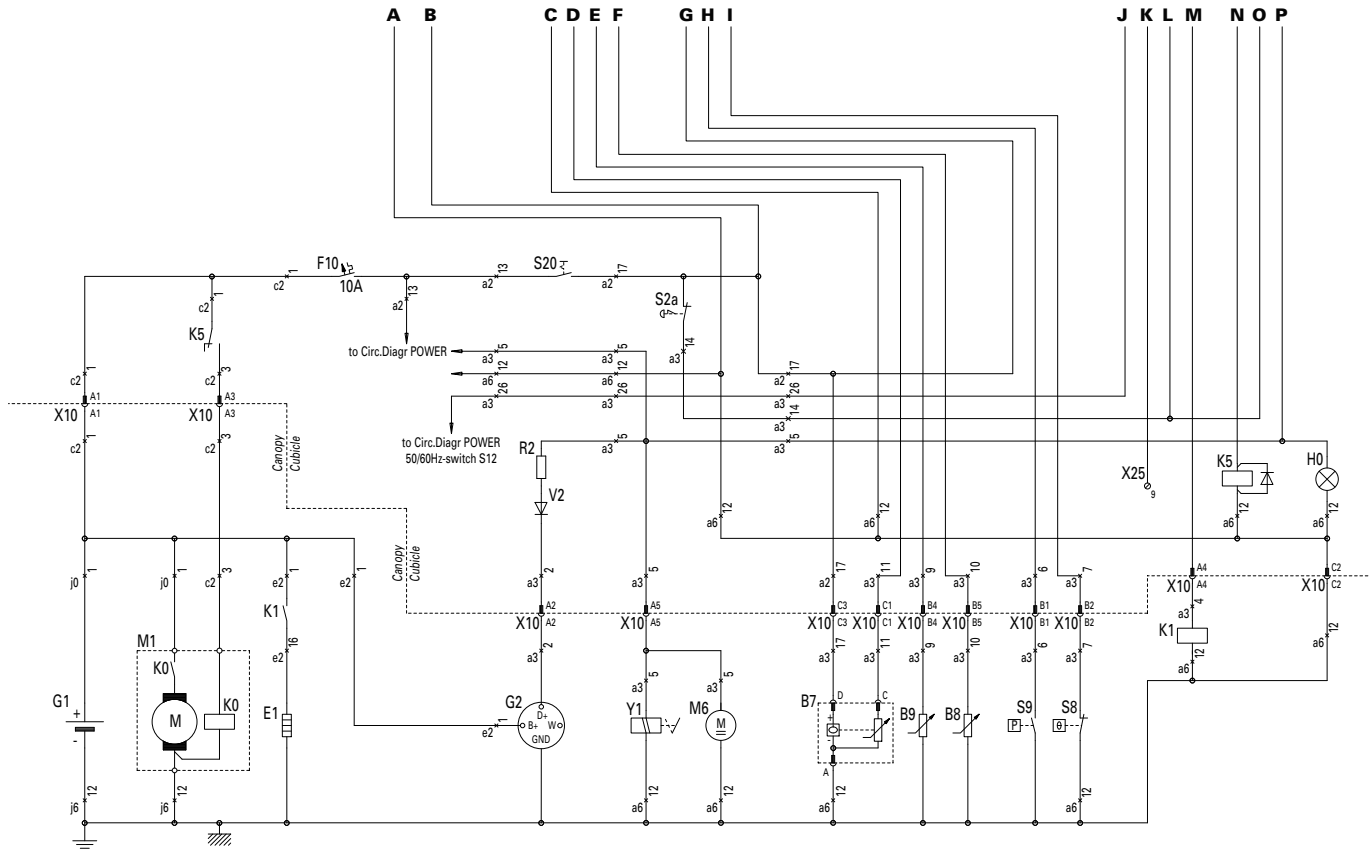

A1	Generator control unit
B7	Fuel level sensor
B8	Coolant temperature sensor
B9	Oil pressure sensor
E1	Preheat resistor
F10	Fuse 10A DC
G1	Battery 12 Vdc
G2	Charging alternator
K0	Starter solenoid
K1	Preheat relay
K5	Starter relay
M1	Starter motor
M6	Fuel feed pump
P1-P3	A-meter
P4	V-meter
R2	Excitation resistor 47ohm
S2a	Emergency stop (S2b: see Power circuit)
S4	V-meter change-over switch
S8	High coolant temperature switch
S9	Low oil pressure switch
S20	ON/OFF-switch
V2	Excitation diode
X10	Connector wire harness
X25	Customer's terminal strip
Y1	Fuel stop solenoid

9822 0996 08/01

Applicable for QAS 60-80-100 Pd - Engine Circuit Qc4002™

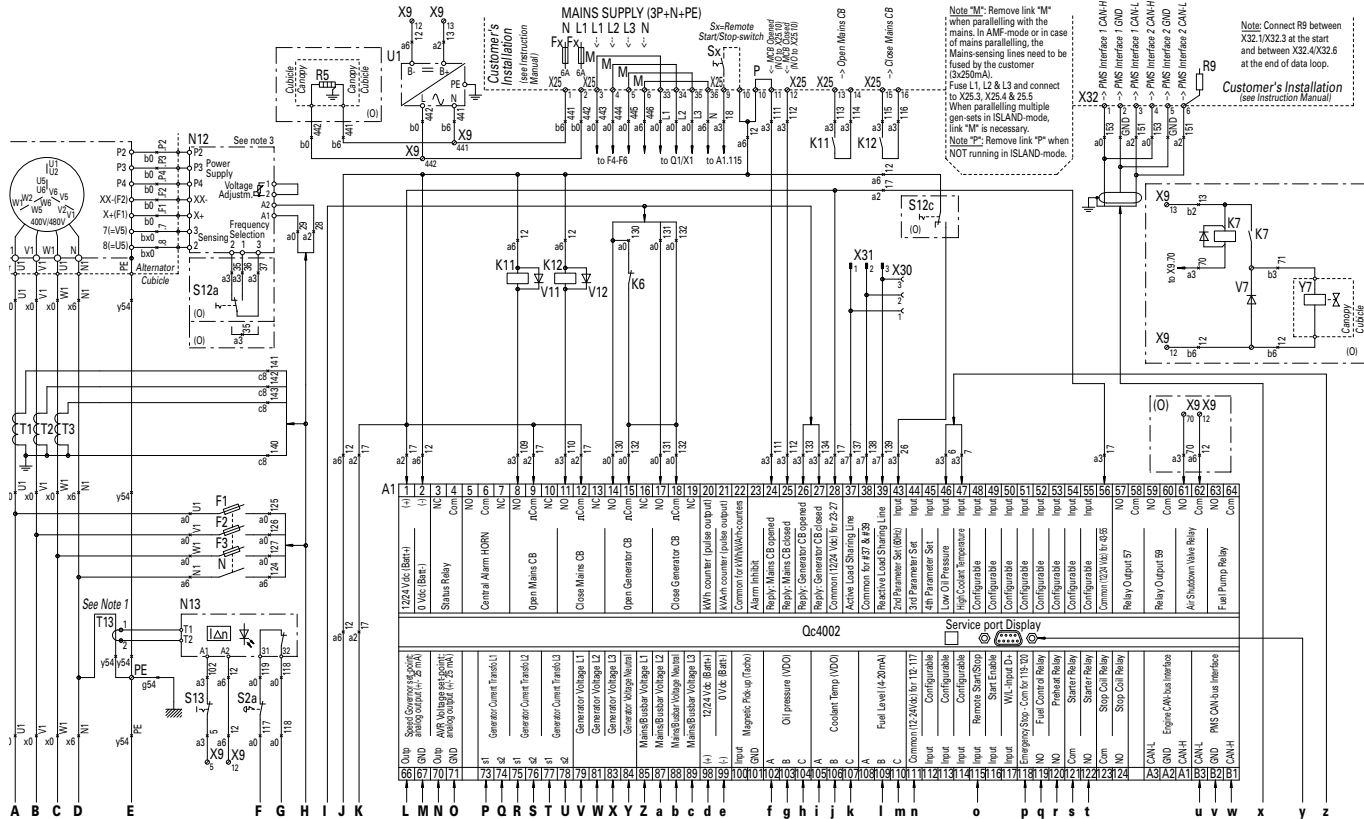

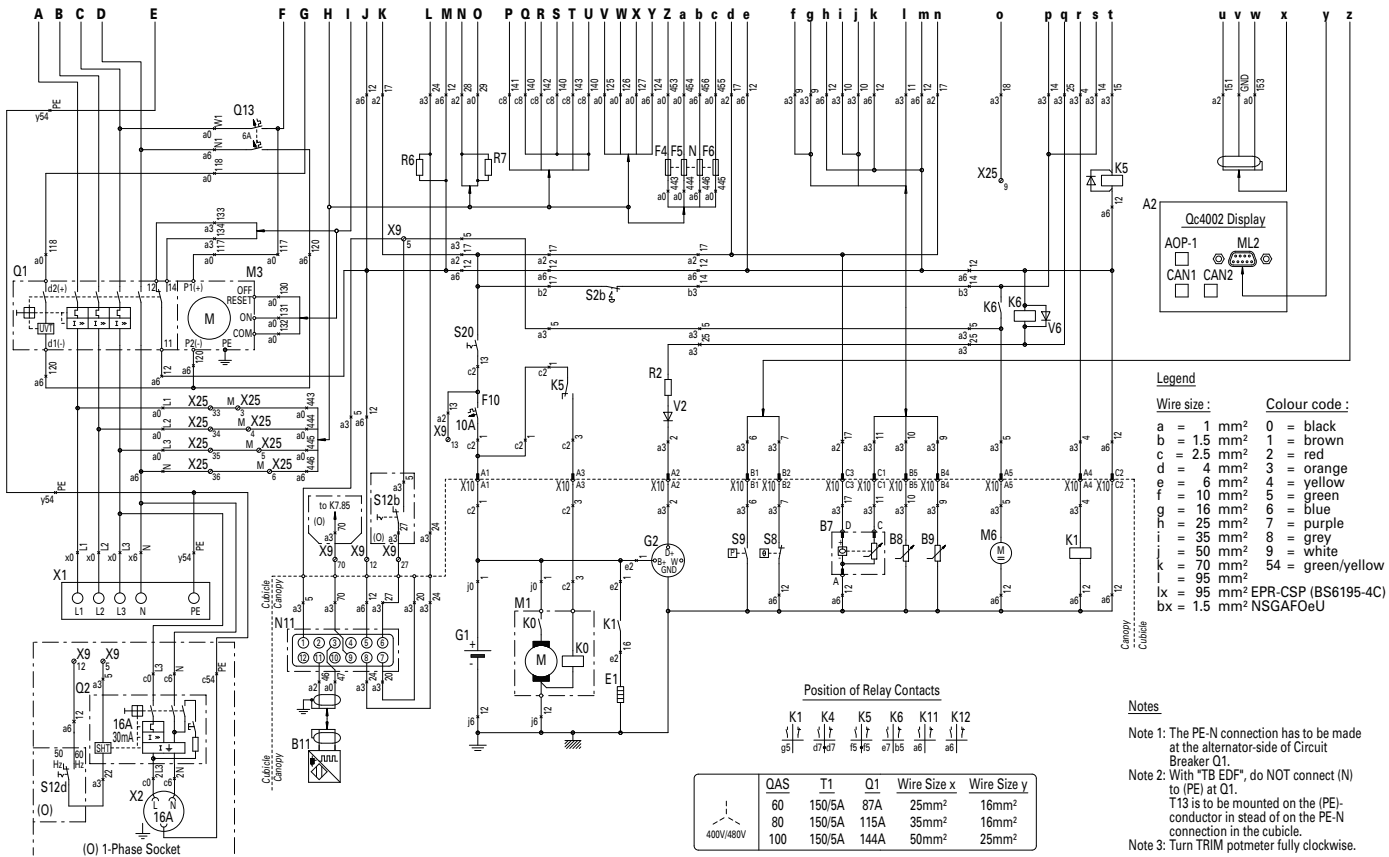

A1	Generator control unit	N11	Speed controller	X1	Terminal board
A2	LCD display	N12	Automatic voltage regulator	X2	Socket outlet (16A-1phase)
A3	PMS CAN-communication	N13	Earth leakage relay	X9	Terminal strip
B7	Fuel level sensor	Q1	Circuit breaker	X10	Connector wire harness
B8	Coolant temperature sensor	Q2	Circuit breaker 16 A	X25	Customer's terminal strip
B9	Oil pressure sensor	Q13	Circuit breaker 6 A	X30, 31	Connector load sharing lines
B11	Speed sensor MPU	R2	Excitation resistor 47 ohm	X32	PMS interface terminals
E1	Preheat resistor	R5	Coolant heater (O)	Y7	Air inlet shutdown valve
F1-6	Fuse 250mA	R6	Resistor 120 Ohm (speed adj)		
F10	Fuse 10A DC	R7	Resistor 220 Ohm (volt adj)		
G1	Battery 12Vdc	R9	Resistor 120 Ohm (PMS CAN-bus)		
G2	Charging alternator	S2	Emergency stop		
G3	Alternator	S8	High coolant temperature switch		
K0	Starter solenoid	S9	Low oil pressure switch		
K1	Prehaet relay	S12	Dual frequency switch		
K4	W/L inverter relay	S13	Earth leak. disable switch		
K5	Starter relay	S20	ON/OFF switch		
K6	Fuel solenoid relay	T1-T3	Current transformers		
K7	Aux.relay for Y7 (O)	T13	Torus earth leakage		
K11	Aux.relay open MCB	U1	Battery charger		
K12	Aux.relay close MCB	V2	Excitation diode		
M1	Starter motor	V6	Free-wheeling diode K6		
M3	Motor drive for Q1	V7	Free-wheeling diode Y7 (O)		
M6	Fuel feed pump	V11,V12	Free-wheeling diode K11,K12		

Following documents are provided with this unit:

- Test Certificate
- EC Declaration of Conformity:



EC DECLARATION OF CONFORMITY

We, Atlas Copco Airpower n.v., declare under our sole responsibility, that the product
 Machine name : **Power generator (< 400 kW)**
 Commercial name :
 Serial number :

Which falls under the provisions of article 12.2 of the EC Directive 2006/42/EC on the approximation of the laws of the Member States relating to machinery, is in conformity with the relevant Essential Health and Safety Requirements of this directive.

The machinery complies also with the requirements of the following directives and their amendments as indicated:

Directive on the approximation of laws of the Member States relating to	Harmonized and/or Technical Standards used	Att: mt
Machinery safety	2006/42/EC EN ISO 12100-1 EN ISO 12100-2 EN 10123-1	
Electromagnetic compatibility	2004/108/EC EN 61000-6-2 EN 61000-6-4	
Low voltage equipment	2006/95/EC EN 60334 EN 60204-1 EN 60439	
Outdoor noise emission	2000/14/EC ISO 3744	x

The harmonized and the technical standards used are identified in the attachments hereafter
 Atlas Copco Airpower n.v. is authorized to compile the technical file

Conformity of the specification to the Directives	Conformity of the product to the specification and by implication to the directives
Issued by Name Signature Place , Date	Product engineering Manufacturing

Form No. 00001006.03
 02.01.2006 10:00:00

Atlas Copco Airpower n.v. A company within the Atlas Copco Group
 Postal address Visitors address Phone: +32 (0)3 870 21 11 Com. Reg. Actwerp 44651
 P.O. Box 100 Boompsteennweg 957 Fax: +32 (0)3 870 24 43 V.A.T. 403.992.231
 B-2010 Willebroek B-2010 Willebroek-Achterep
 Belgium Belgium
 www.atlascopco.com For info, please contact your local Atlas Copco representative

p.1/2



www.atlascopco.com

Printed in Belgium 11/2010 - 2954 3690 01