

RX 70 Technical Data

Diesel and LPG Forklift Truck

[RX 70-20/600](#)

[RX 70-25](#)

[RX 70-25/600](#)

[RX 70-30](#)

[RX 70-30/600](#)

[RX 70-35](#)





			STILL	STILL	STILL	STILL	STILL	STILL	STILL	STILL	STILL	STILL	STILL	STILL		
Distinguishing marks	1.1	Manufacturer														
	1.2	Manufacturer's type designation		RX 70-20/600	RX 70-20T/600	RX 70-25	RX 70-25/600	RX 70-25 T	RX 70-25 T/600	RX 70-30	RX 70-30/600	RX 70-30 T	RX 70-30 T/600	RX 70-35	RX 70-35 T	
	1.2.1	Manufacturer's model number		7394	7400	7395	7396	7401	7402	7397	7398	7403	7404	7399	7405	
	1.3	Drive		Diesel	LPG	Diesel	Diesel	LPG	LPG	Diesel	Diesel	LPG	LPG	Diesel	LPG	
	1.4	Operation		Seated	Seated	Seated	Seated	Seated	Seated	Seated	Seated	Seated	Seated	Seated	Seated	
	1.5	Nominal load capacity/load	Q	kg	2000	2000	2500	2500	2500	2500	3000	3000	3000	3000	3500	3500
	1.6	Load centre distance	c	mm	600	600	500	600	500	600	500	600	500	600	500	500
	1.8	Load distance	x	mm	455	455	455	460	455	460	468	468	468	468	468	468
	1.9	Wheel base	y	mm	1760	1760	1760	1820	1760	1820	1820	1820	1820	1820	1820	1820
Weights	2.1	Service weight		kg	4009	4090	4009	4329	4090	4410	4362	4638	4443	4719	4638	4719
	2.2	Axle load, laden	front/rear	kg	5178/831	5250/840	5763/746	5959/870	5908/682	6032/878	6637/725	6788/850	6710/733	6860/859	7389/749	7462/757
	2.3	Axle load, unladen	front/rear	kg	1980/2020	2051/2039	1980/2030	2003/2326	2051/2039	2076/2334	2042/2321	2028/2611	2114/2329	2100/2619	2028/2611	2100/2619
Tyres/chassis	3.1	Tyres			Superelastic	Superelastic	Superelastic	Superelastic	Superelastic	Superelastic	Superelastic	Superelastic	Superelastic	Superelastic	Superelastic	
	3.2	Tyre size	front		23x9-10	23x9-10	23x9-10	23x9-10	23x9-10	23x9-10	23x9-10	23x10-12	23x9-10	23x10-12	23x10-12	
	3.3	Tyre size	rear		21x8-9	21x8-9	21x8-9	21x8-9	21x8-9	21x8-9	21x8-9	21x8-9	21x8-9	21x8-9	21x8-9	
	3.5	Number of wheels (x = driven)	front/rear		2x/2	2x/2	2x/2	2x/2	2x/2	2x/2	2x/2	2x/2	2x/2	2x/2	2x/2	
	3.6	Track width	front	b ₁₀	mm	992	992	992	992	992	992	952	992	952	952	
	3.7	Track width	rear	b ₁₁	mm	920	920	920	920	920	920	920	920	920	920	
	3.8	Track width			mm	920	920	920	920	920	920	920	920	920	920	
Basic dimensions	4.1	Tilt of mast/fork carriage	forward/backward	α/β	°	6/7	6/7	6/7	6/7	6/7	6/7	6/7	6/7	6/7	6/7	
	4.2	Height of mast	when retracted	h ₁	mm	2175	2175	2175	2175	2175	2175	2175	2175	2175	2175	
	4.3	Free lift		h ₂	mm	160	160	160	160	160	160	160	160	160		
	4.4	Lift		h ₃	mm	2970	2970	2970	2970	2970	2970	2970	2970	2970		
	4.5	Height of mast	when extended	h ₄	mm	3610	3610	3610	3610	3610	3760	3760	3760	3760	3760	
	4.7	Height above protective roof (cab)		h ₆	mm	2190	2190	2190	2190	2190	2190	2195	2190	2195	2195	
	4.8	Seat height in terms of SIP/stand height		h ₇	mm	1220	1220	1220	1220	1220	1220	1220	1220	1220	1220	
	4.12	Coupling height		h ₁₀	mm	340/455	340/455	340/455	340/455	340/455	340/455	340/455	340/455	340/455	340/455	
	4.19	Overall length		l ₁	mm	3607	3607	3607	3702	3607	3702	3775	3702	3775	3775	
	4.20	Length including fork backs		l ₂	mm	2607	2607	2607	2702	2607	2702	2775	2702	2775	2775	
	4.21	Overall width		b ₁	mm	1199	1199	1199	1199	1199	1199	1200	1199	1200	1200	
	4.22	Fork thickness		s	mm	40	40	40	45	40	45	50	50	50	50	
	4.22.1	Fork width		e	mm	100	100	100	100	100	100	100	100	100	100	
	4.22.2	Fork length		l	mm	1000	1000	1000	1000	1000	1000	1000	1000	1000	1000	
	4.23	Fork carriage ISO 2328, class/form A, B				ISO II A	ISO II A	ISO II A	ISO II A	ISO II A	ISO II A	ISO III A	ISO III A	ISO III A	ISO III A	
	4.24	Fork carriage width		b ₃	mm	1150	1150	1150	1150	1150	1150	1150	1150	1150	1150	
	4.31	Ground clearance under mast, laden		m ₁	mm	120	120	120	120	120	115	120	115	120	115	
	4.32	Ground clearance, centre of wheel base		m ₂	mm	140	140	140	140	140	135	140	135	140	140	
	4.33	Working aisle width with 1000 x 1200 pallet crossways		A _{st}	mm	3924	3924	3924	4044	3924	4044	4052	4136	4052	4136	
	4.34	Working aisle width with pallet 800 x 1200 lengthways		A _{st}	mm	4125	4125	4125	4244	4125	4244	4252	4336	4252	4336	
4.35	Turning radius		W _a	mm	2270	2270	2270	2384	2270	2384	2384	2468	2384	2468		
4.36	Smallest pivoting distance		b ₁₃	mm	469	469	469	595	496	595	595	640	595	640		
Performance data	5.1	Travel speed	laden/unladen		km/h	21/21	21/21	21/21	21/21	21/21	21/21	21/21	21/21	21/21	21/21	
	5.2	Lift speed	laden/unladen		m/s	0.63/0.65	0.61/0.63	0.63/0.65	0.63/0.65	0.61/0.63	0.61/0.63	0.58/0.60	0.56/0.60	0.56/0.60	0.58/0.60	
	5.3	Lowering speed	laden/unladen		m/s	0.60/0.53	0.60/0.53	0.60/0.53	0.60/0.53	0.60/0.53	0.60/0.53	0.60/0.53	0.60/0.53	0.60/0.53	0.60/0.53	
	5.5	Drawbar pull, laden			N	23500	17500	24100	24000	18000	21000	24000	23000	25500	24000	
	5.5.1	Drawbar pull, unladen			N	14400	13500	14400	15000	13500	17000	15000	14500	15000	15000	
	5.7	Gradeability	laden/unladen		%	35/30	29/26	37/30	30/27	30/28	32/31	28/27	26/25	32/31	29/25	
	5.9	Acceleration time	laden/unladen		s	4.8/4.4	4.8/4.5	4.9/4.5	5.0/4.5	4.9/4.5	5/4.6	5.1/4.5	5.2/4.6	5/4.6	5.1/4.7	
	5.10	Service brake				Electrical/hydraulic	Electrical/hydraulic	Electrical/hydraulic	Electrical/hydraulic	Electrical/hydraulic	Electrical/hydraulic	Electrical/hydraulic	Electrical/hydraulic	Electrical/hydraulic	Electrical/hydraulic	
	5.11	Service brake				Electrical/hydraulic	Electrical/hydraulic	Electrical/hydraulic	Electrical/hydraulic	Electrical/hydraulic	Electrical/hydraulic	Electrical/hydraulic	Electrical/hydraulic	Electrical/hydraulic	Electrical/hydraulic	
IC engine	7.1	Engine manufacturer				STILL	STILL	STILL	STILL	STILL	STILL	STILL	STILL	STILL		
	7.1.1	Type				DM02VB	PM02V	DM02VB	DM02VB	PM02V	PM02V	DM02VB	DM02VB	PM02V		
	7.2	Engine performance in accordance with ISO 1585		kW	45	36	45	45	36	36	45	45	36	45		
	7.3	Nominal speed		1/min	2150	2150	2150	2150	2150	2150	2150	2150	2150	2150		
	7.4	Number of cylinders			4	4	4	4	4	4	4	4	4	4		
	7.4.1	Capacity		cm ³	2400	2400	2400	2400	2400	2400	2400	2400	2400	2400		
		Emissions level acc. to EU Regulation 2016/1628				EU V	EU V	EU V	EU V	EU V	EU V	EU V	EU V	EU V		
	7.5	Fuel consumption in accordance with EN 16796		l/h kg/h	2.4	2.6	2.5	2.7	2.7	2.8	2.8	2.9	2.8	2.9		
	7.9	On-board voltage		V	12	12	12	12	12	12	12	12	12	12		
Miscellaneous	8.1	Design of the transmission drive				Diesel-electric	Diesel-electric	Diesel-electric	Diesel-electric	Diesel-electric	Diesel-electric	Diesel-electric	Diesel-electric	Diesel-electric		
	10.1	Working pressure for accessory equipment		bar	250	250	250	250	250	250	250	250	250	250		
	10.2	Oil volume for accessory equipment		l/min	35	35	35	35	35	35	35	35	35	35		
	10.4	Fuel tank content		l/kg	58	11	58	58	11	11	58	11	58	11		
	10.7	Sound pressure level L _{paz} ¹ (operator's position)		dB(A)	76	74	76	76	74	74	76	74	74	76		
	10.7.1	Sound power level LWAZ (working cycles)		dB(A)	93	93	93	93	93	93	93	93	93	93		
	10.8	Trailer coupling, item/DIN type				Bolt	Bolt	Bolt	Bolt	Bolt	Bolt	Bolt	Bolt	Bolt		

¹ Without cab, different values with cab

RX 70-20/35 Diesel and LPG Forklift Truck Mast Tables



			Telescopic mast								HiLo mast						Triplex mast									
RX 70-25 / RX 70-20/600	Nominal lift	h_3	mm	2870	2970	3170	3270	3670	4170	4570	5070	2990	3090	3290	3690	4090	4590	4440	4590	4890	5390	5690	6040	6640	7390	
	Height	h_1	mm	2125	2175	2275	2325	2525	2775	2975	3225	2125	2175	2275	2475	2675	2925	2125	2175	2275	2475	2575	2725	2925	3175	
	Free lift	h_2	mm	160	160	160	160	160	160	160	160	1500	1550	1650	1850	2050	2300	1500	1550	1650	1850	1950	2100	2300	2550	
	Maximum height, 4-roller fork carriage	h_4	mm	3510	3610	3810	3910	4310	4810	5210	5710	3650	3750	3950	4350	4750	5250	5120	5270	5570	6070	6370	6720	7320	8070	
	Tilt of mast/fork carriage	forward/backward	α/β	°	6/7								6/7						6/7							
RX 70-25 / RX 70-20/600	Fork lock-in position centre-centre		mm	216 / 368 / 535 / 673 / 826 / 902 (4R 1150 mm)												267 / 368 / 437 / 673 / 876 (4R 1150 mm)										
	Tyres	front/rear		23*9-10/21*8-9						23*9-10/21*8-9						23*9-10/21*8-9										
	Track	front/rear	mm	992/920						992/920						992/920			1096/920							
	Maximum width	b_1	mm	1199						1199						1199			1303							
	Nominal lift	h_3	mm	2870	2970	3170	3270	3670	4170	4570	5070	2990	3090	3290	3690	4090	4590	4440	4590	4890	5390	5690	6040	6640	7390	
RX 70-25 / RX 70-20/600	Height	h_1	mm	2125	2175	2275	2325	2525	2775	2975	3225	2125	2175	2275	2475	2675	2925	2125	2175	2275	2475	2575	2725	2925	3175	
	Free lift	h_2	mm	160	160	160	160	160	160	160	160	1500	1550	1650	1850	2050	2300	1500	1550	1650	1850	1950	2100	2300	2550	
	Maximum height, 4-roller fork carriage	h_4	mm	3510	3610	3810	3910	4310	4810	5210	5710	3650	3750	3950	4350	4750	5250	5120	5270	5570	6070	6370	6720	7320	8070	
	Tilt of mast/fork carriage	forward/backward	α/β	°	6/7								6/7						6/7							
	Fork lock-in position centre-centre		mm	216 / 368 / 535 / 673 / 826 / 902 (4R 1150 mm)												267 / 368 / 439 / 673 / 876 (4R 1150 mm)										
RX 70-30	Tyres	front/rear		23*9-10/21*8-9						23*9-10/21*8-9						23*9-10/21*8-9			23*10-12/21*8-9			315/45-12 // 21*8-9				
	Track	front/rear	mm	992/920						992/920						992/920			1050/920			1100/920				
	Maximum width	b_1	mm	1199						1199						1199			1298			1399				
	Nominal lift	h_3	mm	2870	2970	3170	3270	3670	4170	4570	5070	2990	3090	3290	3690	4090	4590	4440	4590	4890	5190	5390	5690	6040	6640	7390
	Height	h_1	mm	2125	2175	2275	2325	2525	2775	2975	3225	2125	2175	2275	2475	2675	2925	2125	2175	2275	2375	2475	2575	2725	2925	3175
RX 70-30	Free lift	h_2	mm	160	160	160	160	160	160	160	160	1490	1540	1640	1840	2040	2290	1490	1540	1640	1740	1840	1940	2090	2290	2540
	Maximum height, 4-roller fork carriage	h_4	mm	3660	3760	3960	4060	4460	4960	5360	5860	3660	3760	3960	4360	4760	5260	5120	5270	5570	5870	6070	6370	6720	7320	8070
	Tilt of mast/fork carriage	forward/backward	α/β	°	6/7								6/7						6/7							
	Fork lock-in position centre-centre		mm	267 / 368 / 540 / 673 / 876 (4R 1150 mm)												267 / 368 / 439 / 673 / 876 (4R 1150 mm)										
	Tyres	front/rear		23*9-10/21*8-9						23*9-10/21*8-9						23*9-10/21*8-9			23*10-12/21*8-9			315/45-12 // 21*8-9				
RX 70-30 / RX 70-30/600	Track	front/rear	mm	992/920						992/920						992/920			1050/920			1100/920				
	Maximum width	b_1	mm	1199						1199						1199			1298			1399				
	Nominal lift	h_3	mm	2870	2970	3170	3270	3670	4170	4570	5070	2990	3090	3290	3690	4090	4590	4440	4590	4890	5190	5390	5690	6040	6640	7390
	Height	h_1	mm	2125	2175	2275	2325	2525	2775	2975	3225	2125	2175	2275	2475	2675	2925	2125	2175	2275	2375	2475	2575	2725	2925	3175
	Free lift	h_2	mm	160	160	160	160	160	160	160	160	1490	1540	1640	1840	2040	2290	1490	1540	1640	1740	1840	1940	2090	2290	2540
RX 70-35 // RX 70-30/600	Maximum height, 4-roller fork carriage	h_4	mm	3660	3760	3960	4060	4460	4960	5360	5860	3660	3760	3960	4360	4760	5260	5120	5270	5570	5870	6070	6370	6720	7320	8070
	Tilt of mast/fork carriage	forward/backward	α/β	°	6/7								6/7						6/7							
	Fork lock-in position centre-centre		mm	267 / 368 / 540 / 673 / 876 (4R 1150 mm)												267 / 368 / 439 / 673 / 876 (4R 1150 mm)										
	Tyres	front/rear		23*10-12/21*8-9						23*10-12/21*8-9						23*10-12/21*8-9			315/45-12 // 21*8-9							
	Track	front/rear	mm	952/920						1050/920						952/920			1050/920			1100/920				
RX 70-35 // RX 70-30/600	Maximum width	b_1	mm	1200						1298						1200			1298			1399				

Technical Drawings

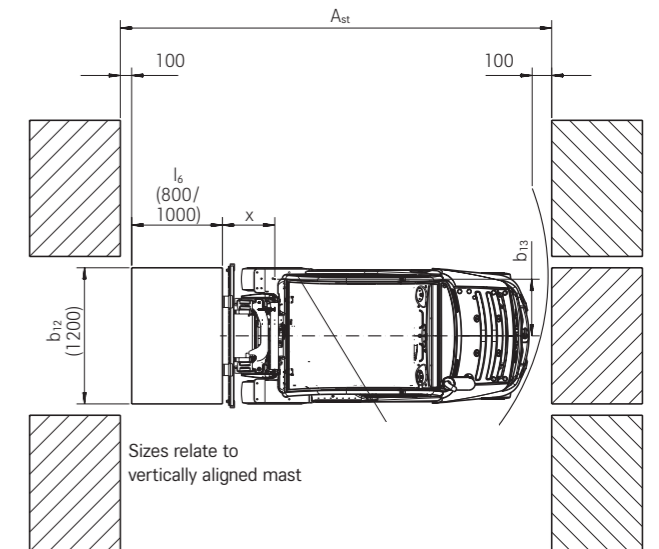
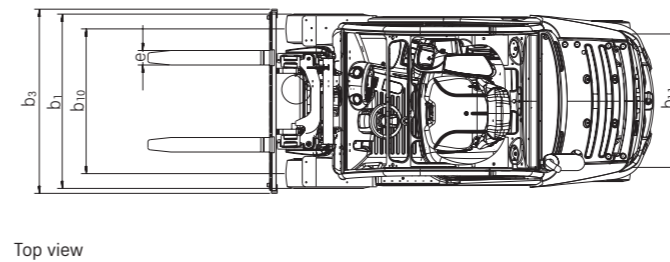
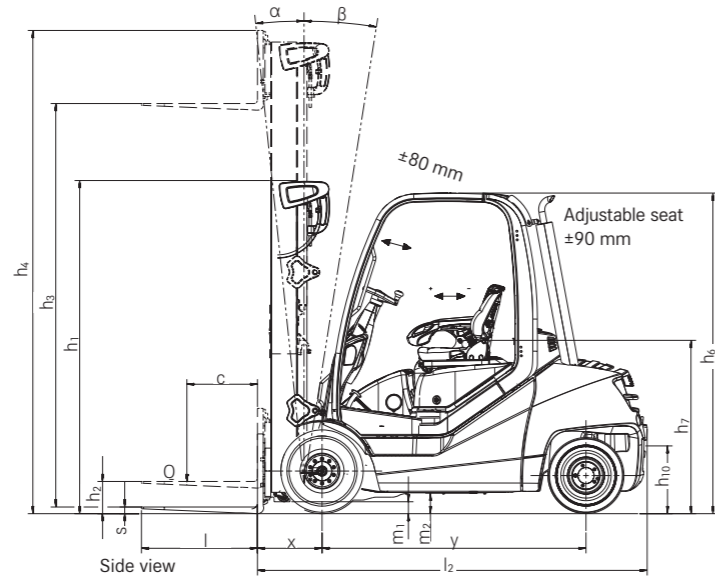

RX 70-20/35 Diesel and LPG Forklift Truck

Basic Load Capacities

RX 70-20/600 Telescopic/HiLo mast
Single superelastic tyres

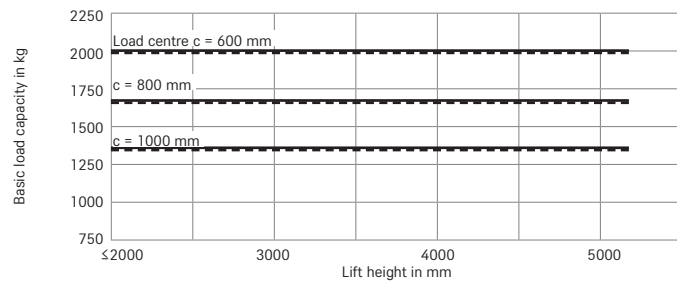

RX 70-20/600 600 triplex mast
Single superelastic tyres

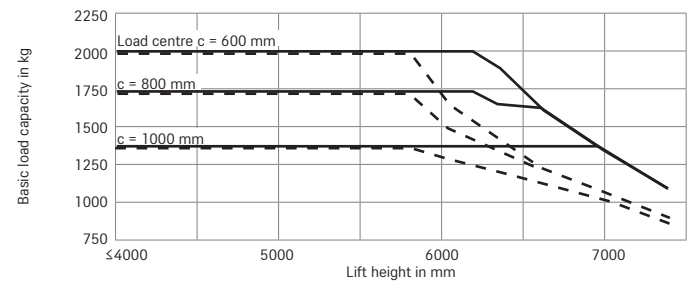

RX 70-25 Telescopic/HiLo mast
Single superelastic tyres

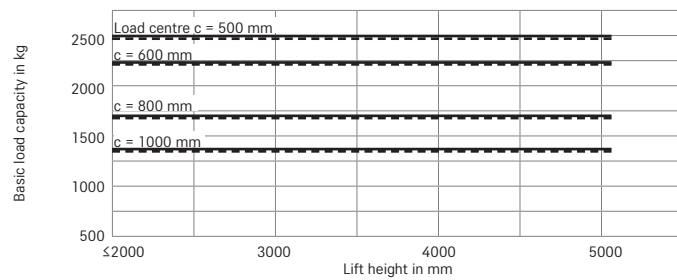

RX 70-25 triplex mast
Single superelastic tyres

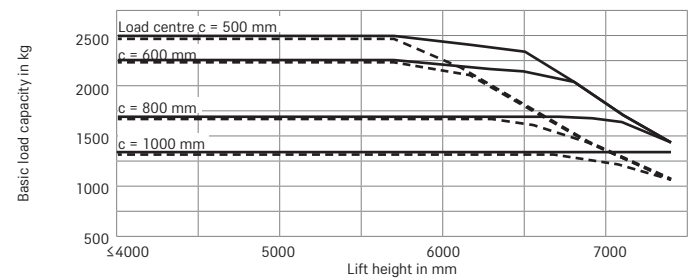

RX 70-25/600 Telescopic/HiLo mast
Single superelastic tyres

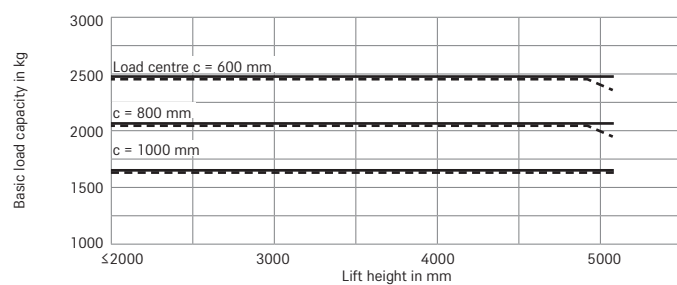

RX 70-25/600 triplex mast
Single superelastic tyres

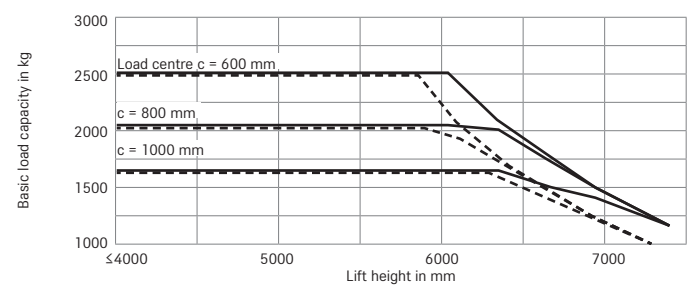

— With standard forks - - - With integrated side shifter and standard forks
The listed values may vary depending on the truck's features.

RX 70-20/35 Diesel and LPG Forklift Truck

Basic Load Capacities

RX 70-30 Telescopic/HiLo mast
Single superelastic tyres

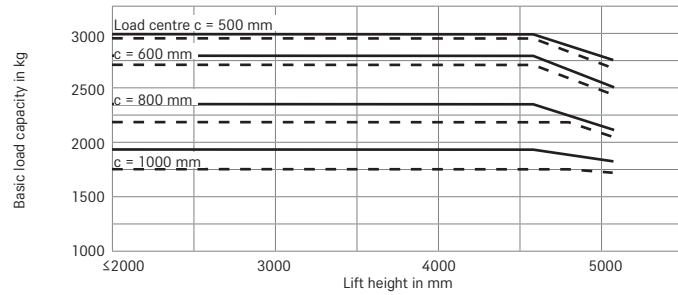

RX 70-30 triplex mast
Single superelastic tyres

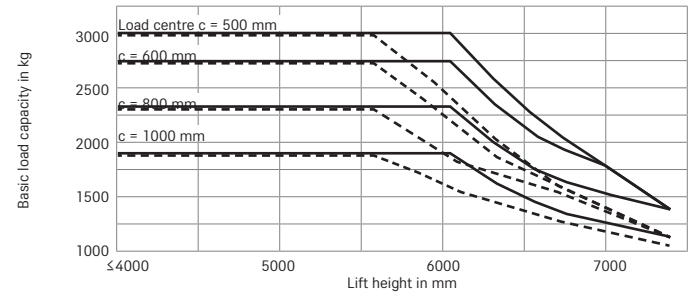

RX 70-30/600 Telescopic/HiLo mast
Single superelastic tyres

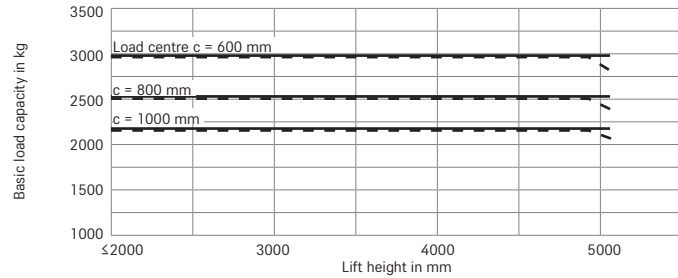

RX 70-30/600 triplex mast
Single superelastic tyres

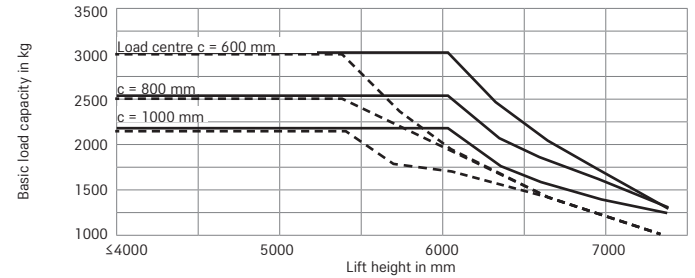

RX 70-35 Telescopic/HiLo mast
Single superelastic tyres

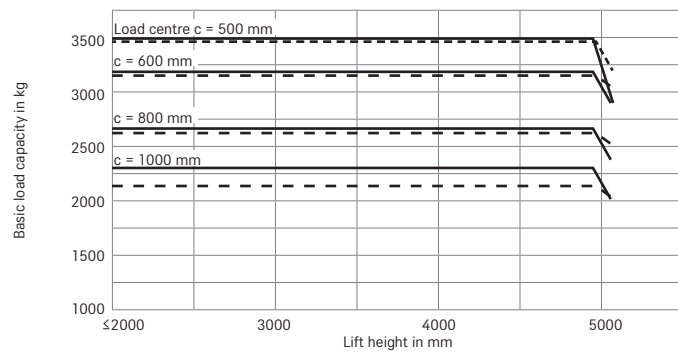

RX 70-35 triplex mast
Single superelastic tyres

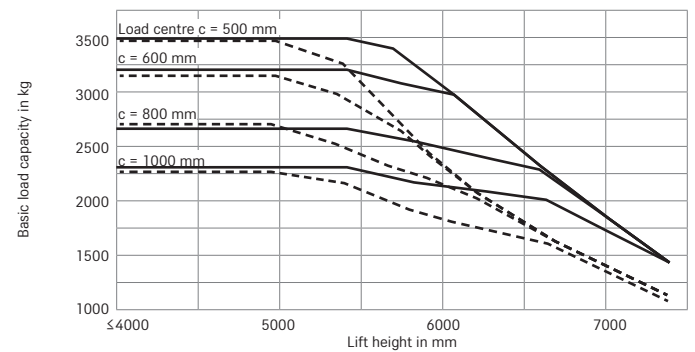

— With standard forks - - - With integrated side shifter and standard forks
The listed values may vary depending on the truck's features.

RX 70-20/35 Diesel and LPG Forklift Truck
Detailed Photos



For better performance: comfortable and ergonomic driver's cab for fatigue-free operation

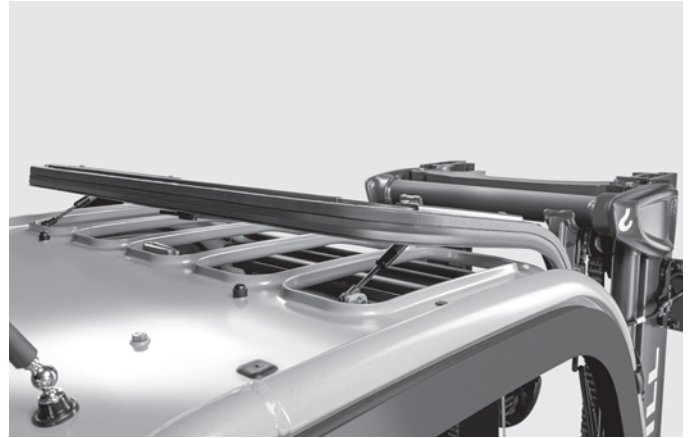

Adjustable roof window for a comfortable workplace climate

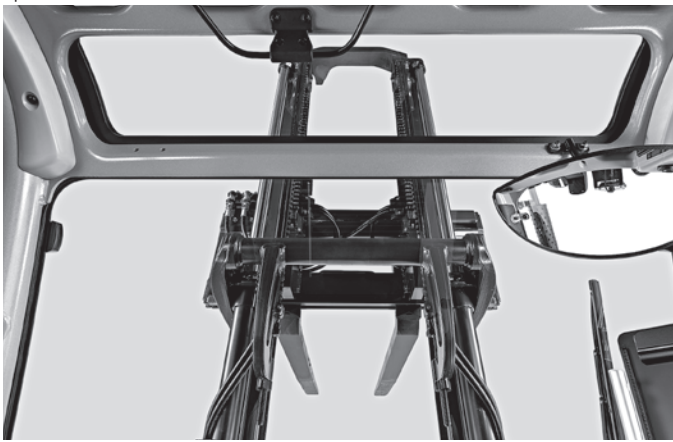

Optimal panoramic view: slim mast and extra-large window



Everything in view at all times: sun blind for the windscreen as well as the roof and rear window



Perfect stability in every position thanks to the electro-hydraulic parking brake



User-friendly: plenty of space for the driver for all-round efficient operation



Individual adjustment of the steering column



Safe, intuitive operation with the STILL Easy Control display and control module

RX 70-20/35 Diesel and LPG Forklift Truck Performance meets efficiency

Powerful, efficient and precise: STILL Performance System with perfectly coordinated components

Complete control: the STILL Easy Control on-board computer - performance functions at the push of a button, relevant info at a glance

Clear view ahead: optimal visibility thanks to the slim mast, large windows and thermoformed dashboard



Full speed ahead: the industrial engine with over 20 percent more power means that the RX 70-20/35 can move more goods to their destination even faster – and yet it remains impressively efficient! This is made possible by the STILL Performance System: perfectly coordinated components combine a powerful and efficient drive with precise and sensitive control. Every RX 70-20/35 is built to impress for years: durable material and compact design meet unmatched performance dynamics. The top performer has a multitude of strengths that are effectively adapted to every situation thanks to the intuitive operating elements. What's more, every detail of the comfortable

driver's cab has been carefully considered, from the large footwell through to the thermoformed dashboard for maximum visibility. The STILL Easy Control is the cockpit's smart centrepiece. The smart on-board computer provides direct access to performance functions and displays relevant truck information at a glance. Reversing in tight spaces, frequent driving up and down ramps, changing operating conditions – with the RX 70-20/35 you have the load handling under control at all times, even in tough and challenging situations. Experience intelligent performance at its best!

The 'Simply Efficient' factors: Performance attributes as a measure of economic efficiency



Simply easy

- Intuitive handling: standard, easy-to-use operating concept across the whole RX product line
- Climb in, get comfortable and get going: spacious driver's cab with adjustable steering column
- One glance or click is all you need: the STILL Easy Control on-board computer activates performance functions at the push of a button and displays all the relevant information at a glance
- Work made easier: a range of assistance functions make work easier and improve safety



Simply powerful

- Strong performance: powerful drive meets precise control
- Effective goods handling: travel speed of up to 21 km/h
- Agile performance: parallel operation makes it possible to drive and lift or tilt at the same time
- Flexible power control: electrically adjustable hydraulic pump
- The new STILL Performance System perfectly coordinates the entire system of all drive components and operating functions
- The powerful and quiet diesel-electric drive in hybrid technology ensures exceptional handling performance with low consumption, low noise emissions and minimised environmental impact



Simply safe

- Perfect all-round view: large viewing window, also in the protective roof
- Good tracking and stability: outstanding driving stability when turning and a low centre of gravity
- Guided safety check: the truck is released after a display-guided function check
- Safe entry and exit: large non-slip steps that are also visible from above as well as grab handles on the protective roof
- Consistent drive power: every drive wheel is separately controlled and makes sure that the truck is always kept on track



Simply flexible

- Flexible control options: mini-lever, Fingertip or Joystick 4Plus
- Safety and comfort in every situation: flexibly adjustable driving and lifting performance
- Perfectly tailored operating power: extensive equipment options for maximum performance in every application



Simply connected

- Digital Performance Boost: optional interface for integration into fleet management software, such as STILL neXXt fleet
- Flexible networking: the provision for MMS means that the truck can be integrated into every material flow management system with ease

RX 70-20/35 Diesel and LPG Forklift Truck
Equipment Variants



	RX 70-20/600	RX 70-20/600 T ¹	RX 70-25	RX 70-25 T ¹	RX 70-25/600	RX 70-25/600 T ¹	RX 70-30	RX 70-30 T ¹	RX 70-30/600	RX 70-30/600 T ¹	RX 70-35	RX 70-35 T ¹
Driver's cab												
Impact-absorbing driver's seat for optimal comfort on uneven routes	●	●	●	●	●	●	●	●	●	●	●	●
Protective steel roof	●	●	●	●	●	●	●	●	●	●	●	●
Weather protection design in different variants	○	○	○	○	○	○	○	○	○	○	○	○
Driver's cab	○	○	○	○	○	○	○	○	○	○	○	○
Tarpaulin cab	○	○	○	○	○	○	○	○	○	○	○	○
Tinted front windscreen, rear and front windows, windscreen washing/wiping facility	○	○	○	○	○	○	○	○	○	○	○	○
Driver's cab set low, height approx. 2120 mm	○	○	○	○	○	○	○	○	○	○	○	○
Single-pedal drive control	●	●	●	●	●	●	●	●	●	●	●	●
Double-pedal drive control	○	○	○	○	○	○	○	○	○	○	○	○
Built-in storage and drink holder	●	●	●	●	●	●	●	●	●	●	●	●
Display and function buttons protected from water spray	●	●	●	●	●	●	●	●	●	●	●	●
Writing pad support and clipboard (removable) with a light	○	○	○	○	○	○	○	○	○	○	○	○
Grammer driver's seat with leatherette cover	●	●	●	●	●	●	●	●	●	●	●	●
Grammer comfort driver's seat with textile cover and lumbar support	○	○	○	○	○	○	○	○	○	○	○	○
Grammer driver's seat exclusively with leatherette or textile cover, mechanical or airsprung, extra-wide seat pad, large suspension travel, lumbar support, height-adjustable back extension and heated seat	○	○	○	○	○	○	○	○	○	○	○	○
Horizontal spring plate for driver's seat to minimise human vibrations	○	○	○	○	○	○	○	○	○	○	○	○
Colour display with intuitive menu layout	●	●	●	●	●	●	●	●	●	●	●	●
12 V truck power socket and USB plug	●	●	●	●	●	●	●	●	●	●	●	●
Bluetooth hands-free DAB+ radio/MP3 player with USB plug	○	○	○	○	○	○	○	○	○	○	○	○
Adjustable roof window	○	○	○	○	○	○	○	○	○	○	○	○
Protective sunshade and sun blind	○	○	○	○	○	○	○	○	○	○	○	○
Water heating with blower and defroster nozzles for front windscreen and footwell	○	○	○	○	○	○	○	○	○	○	○	○
Air conditioning	○	○	○	○	○	○	○	○	○	○	○	○
Telescopic free view mast with and without full free lift	○	○	○	○	○	○	○	○	○	○	○	○
Triplex free view mast	○	○	○	○	○	○	○	○	○	○	○	○
Fork wear protection	○	○	○	○	○	○	○	○	○	○	○	○
Different fork carriage widths, integrated side shifter and fork adjusters	○	○	○	○	○	○	○	○	○	○	○	○
Load backrest	○	○	○	○	○	○	○	○	○	○	○	○
Automatic vertical mast position	○	○	○	○	○	○	○	○	○	○	○	○
Hydraulic accumulator in the lifting cylinder to attenuate pressure peaks in the hydraulic system	○	○	○	○	○	○	○	○	○	○	○	○
Angle of incline 6/7 degrees front/rear incline	●	●	●	●	●	●	●	●	●	●	●	●
Superelastic tyres, SIT system, single or twin	●	●	●	●	●	●	●	●	●	●	●	●
Superelastic tyres, SIT system, natural colour or anti-static	○	○	○	○	○	○	○	○	○	○	○	○
Pneumatic tyres, single or twin	○	○	○	○	○	○	○	○	○	○	○	○
Hydraulics												
Proportional valve technology for especially sensitive movements	●	●	●	●	●	●	●	●	●	●	●	●
Up to three hydraulic circuits for controlling accessories	○	○	○	○	○	○	○	○	○	○	○	○
Custom parametrisation of hydraulic functions	●	●	●	●	●	●	●	●	●	●	●	●
Mini-lever with armrest, two levers	●	●	●	●	●	●	●	●	●	●	●	●
Mini-lever with armrest, three or four levers, Joystick 4Plus or Fingertip	○	○	○	○	○	○	○	○	○	○	○	○
Five driving programmes for different driving and braking behaviour	●	●	●	●	●	●	●	●	●	●	●	●
Blue-Q energy saving mode	●	●	●	●	●	●	●	●	●	●	●	●
Smooth acceleration and reversing	●	●	●	●	●	●	●	●	●	●	●	●
Maintenance-free drives for driving, steering and lifting	●	●	●	●	●	●	●	●	●	●	●	●
Travel and lift drive components enclosed to protect against dust and dirt	●	●	●	●	●	●	●	●	●	●	●	●
Dry air filter with maintenance indicator	●	●	●	●	●	●	●	●	●	●	●	●
Additional air filter or cyclone pre-separator	○	○	○	○	○	○	○	○	○	○	○	○
55 l and 70 l LPG tanks	—	○	—	○	—	○	—	○	—	○	—	○
Automatic engine shut-off	○	○	○	○	○	○	○	○	○	○	○	○
Engine preheating via external power connection	○	○	○	○	○	○	○	○	○	○	○	○
Regulated three-way catalytic converter	○	●	○	●	○	●	○	●	○	●	○	●
Additional insulation package to lower noise emission	○	○	○	○	○	○	○	○	○	○	○	○
Diesel particle filter	●	●	●	●	●	●	●	●	●	●	●	●
Brake												
Wear-free disc brakes that run in an oil bath	●	●	●	●	●	●	●	●	●	●	●	●
Electro-hydraulic parking brake	●	●	●	●	●	●	●	●	●	●	●	●
Safety												
Low centre of gravity and steering axle with high self-aligning bearing for optimum levels of safety	●	●	●	●	●	●	●	●	●	●	●	●
Simple and safe entry and exit via large non-slip steps	●	●	●	●	●	●	●	●	●	●	●	●
Protective grille roof	○	○	○	○	○	○	○	○	○	○	○	○
Narrow protective roof profile for an optimum all-round view	●	●	●	●	●	●	●	●	●	●	●	●
EasyBelt restraint system for quick and safe fastening and unfastening	○	○	○	○	○	○	○	○	○	○	○	○
IWS restraint system with strap opening located on both sides	○	○	○	○	○	○	○	○	○	○	○	○
Lighting system with LED design, approvable	○	○	○	○	○	○	○	○	○	○	○	○
Working lights with LED design	○	○	○	○	○	○	○	○	○	○	○	○
Warning flash light	○	○	○	○	○	○	○	○	○	○	○	○
STILL Safety Light warning device, illuminated blue	○	○	○	○	○	○	○	○	○	○	○	○
Seat belt control, drive unit only enabled when seat belt is fastened	●	●	●	●	●	●	●	●	●	●	●	●
Curve Speed Control	●	●	●	●	●	●	●	●	●	●	●	●
Speed limiter adjustable by driver	○	○	○	○	○	○	○	○	○	○	○	○
Tempomat cruise control	○	○	○	○	○	○	○	○	○	○	○	○
Lifting height sensor for exact measurement of the lifting height with optional assistance functions	○	○	○	○	○	○	○	○	○	○	○	○
Stability assistant Dynamic Load Control	○	○	○	○	○	○	○	○	○	○	○	○
Load measuring with ±2% precision	○	○	○	○	○	○	○	○	○	○	○	○
FleetManager: access authorisation, shock detection, reports	○	○	○	○	○	○	○	○	○	○	○	○

¹ LPG ● Standard ○ Option — Not available



STILL GmbH
Berzeliusstr. 10
22113 Hamburg
Germany
Tel.: +49 40 73 39 20 00
Fax: +49 40 73 39 20 01
info@still.de

For further information please visit
www.still.eu

STILL is certified in the following areas: Quality management, occupational safety, environmental protection and energy management.



first in intralogistics