



**WACKER  
NEUSON**  
*all it takes!*

## Operator's manual

## Mobile excavator

# EW65



<b>Machine models</b>	<b>E14-02</b>
<b>Edition</b>	<b>1.5</b>
<b>Document order number</b>	<b>5100024873</b>
<b>Language</b>	<b>us/us</b>
<b>From serial number</b>	<b>WNCE1402PPAL00162</b>

This Operator's Manual includes  
the AEM Safety Manual



Documentation	Language	Order no.
Operator's manual	us/us	5100024873
Spare parts catalog EW65 (E14-02)	de/en/fr	1000346413
	de/it/es	1000346414

Legend	
<b>Original Operator's Manual</b>	<b>x</b>
<b>Translation</b> of original Operator's Manual	–
Issue	1.5
Date	03/2022
Document	BA E14 wheel us/us*

Copyright © 2022 Wacker Neuson Linz GmbH, Hörsching

Printed in Austria

All rights reserved, in particular the copyright, the right of reproduction and the right of distribution applicable worldwide.

This document may be used by the receiver only for the designated purpose. It may in no way be duplicated or translated in any other language, in whole or in part, without prior permission in writing from the manufacturer.

No reproduction or translation of this publication, in whole or in part, without the written consent from Wacker Neuson Linz GmbH.

Violations of legal regulations, in particular of the copyright protection, will be subject to civil and criminal prosecution.

Wacker Neuson Linz GmbH keep abreast of the latest technical developments and constantly improve their products. For this reason, we may from time to time need to make changes to figures and descriptions in this documentation that do not reflect products that have already been delivered and that will not be implemented on these machines.

Technical data, dimensions and weights are only given as an indication. Non-metric values are rounded off. Responsibility for errors or omissions not accepted.

The cover features the vehicle with possible optional equipment. Not all options in this operator's manual must be available in every destination country.

Photographs and graphics are symbolic representations and may differ from the actual products.

Wacker Neuson is authorized to publish copyright-protected material, for example that owned by Perkins Engines Company Ltd.

The Operator's Manual and any amendments to it must always be available at the location where the vehicle is operated. Possible amendments are included at the end of the Operator's Manual.



Wacker Neuson Linz GmbH

Flughafenstraße 7

A-4063 Hörsching

Phone: +43 (0) 7221 63000

Fax: +43 (0) 7221 63000-2200

E-mail: office.linz@wackerneuson.com

www.wackerneuson.com

---

 **WARNING**

The engine exhaust from this product contains chemicals known to the State of California to cause cancer, birth defects, or other reproductive harm.

---

---

 **WARNING**

Diesel engine exhaust and some of its constituents are known to the State of California to cause cancer, birth defects, and other reproductive harm.

---

---

 **WARNING**

Cancer and Reproductive Harm -  
[www.P65Warnings.ca.gov](http://www.P65Warnings.ca.gov).

---

---

 **WARNING**

Batteries, battery posts, terminals and related accessories contain lead and lead compounds, and other chemicals known to the State of California to cause cancer and birth defects or other reproductive harm.  
WASH HANDS AFTER HANDLING.

---



**Notes:**

# Table of contents

<b>1 Foreword</b>	
1.1 Operator's manual .....	1-1
1.2 Warranty and liability .....	1-8
<b>2 Safety</b>	
2.1 Safety symbols and signal words .....	2-1
2.2 Qualification of operating personnel .....	2-2
2.3 Conduct .....	2-3
2.4 Operation .....	2-4
2.5 Lifting gear applications .....	2-8
2.6 Trailer operation .....	2-11
2.7 Attachment operation .....	2-11
2.8 Towing, loading and transporting .....	2-13
2.9 Maintenance .....	2-15
2.10 Measures for avoiding risks .....	2-18
<b>3 Introduction</b>	
3.1 Machine overview .....	3-1
3.2 Brief description of the vehicle .....	3-2
3.3 Information and regulations on use .....	3-4
3.4 Labels .....	3-6
<b>4 Putting into operation</b>	
4.1 Cabin/control stand .....	4-1
4.2 Overview of control elements .....	4-29
4.3 Control and warning lights overview .....	4-36
4.4 Preparatory work .....	4-45
4.5 Starting and stopping the engine .....	4-50
<b>5 Operation</b>	
5.1 Steering system .....	5-1
5.2 Accelerator actuation .....	5-1
5.3 Brakes .....	5-6
5.4 Machine travel .....	5-9
5.5 Differential lock .....	5-29
5.6 Lights/signaling system .....	5-29
5.7 Wiper/wash system .....	5-34
5.8 Heating, ventilation and air conditioning system .....	5-35
5.9 Operating hydraulics .....	5-37
5.10 Attachments .....	5-76
5.11 Work operation .....	5-80
5.12 Emergency lowering .....	5-88
5.13 Options .....	5-89
5.14 Putting out of operation/back into operation .....	5-93
5.15 Permanently putting out of operation .....	5-95
<b>6 Transportation</b>	
6.1 Towing the vehicle .....	6-1
6.2 Loading the vehicle .....	6-7
6.3 Transporting the vehicle .....	6-12



<b>7</b>	<b>Maintenance</b>	
7.1	Information on maintenance .....	7-1
7.2	Maintenance overview .....	7-2
7.3	Fluids and lubricants .....	7-21
7.4	Maintenance accesses .....	7-25
7.5	Cleaning and maintenance .....	7-29
7.6	Lubrication work.....	7-31
7.7	Fuel system .....	7-32
7.8	Engine lubrication system.....	7-40
7.9	Cooling system .....	7-43
7.10	Air filter.....	7-46
7.11	V-belt .....	7-47
7.12	Hydraulic system .....	7-47
7.13	Electrical system.....	7-52
7.14	Heating, ventilation and air conditioning system.....	7-53
7.15	Washer system .....	7-53
7.16	Axles/traveling drive.....	7-53
7.17	Braking system .....	7-53
7.18	Tires .....	7-54
7.19	Maintenance of attachments.....	7-58
7.20	Maintenance of options.....	7-58
7.21	Exhaust gas cleaning (404F-22T).....	7-59
7.22	Exhaust gas cleaning (404J-E22T).....	7-68
7.23	Machine preservation .....	7-73
<b>8</b>	<b>Malfunctions</b>	
8.1	Diesel engine.....	8-1
8.2	Malfunctions (display element/multi-functional display).....	8-3
<b>9</b>	<b>Technical data</b>	
9.1	Models and trade names .....	9-1
9.2	Engine.....	9-1
9.3	Traveling drive .....	9-3
9.4	Brakes.....	9-3
9.5	Tires .....	9-4
9.6	Steering system .....	9-4
9.7	Operating hydraulics.....	9-4
9.8	Electrical system.....	9-5
9.9	Tightening torques .....	9-10
9.10	Coolant .....	9-12
9.11	Noise emissions.....	9-12
9.12	Vibrations.....	9-12
9.13	Weights.....	9-13
9.14	Lift capacity/load .....	9-17
9.15	Dimensions .....	9-44



**EC Declaration of Conformity**

**Manufacturer**

Wacker Neuson Linz GmbH, Flughafenstraße 7, 4063 Hörsching, Austria



**Product**

Machine designation	<b>Hydraulic excavator</b>
Machine model	
Trade name	
Serial number	
Engine/output kW	
Measured sound power level dB(A)	
Guaranteed sound power level dB(A)	

**Conformity assessment procedure**

Notified body according to directive 2006/42/EC, appendix XI:  
DGUV Test, test and certification body  
construction department, Am Knie 6, 81241 München, Germany  
Notified body of the EU, identification number: 0515

**For 2000/14/EG notified body involved in procedure**

Industrial Supervisory Board SÜD Industrie Service GmbH  
Westendstraße 199  
D 80686 München  
Notified Body of the EU, identification number: 0036

**Directives and standards**

We hereby declare that this product corresponds to the relevant regulations of the following Directives and standards:

2006/42/EG, 2005/88/EG, 2000/14/EG - Appendix VIII, 2014/30/EU, 2014/53/EU (if telematics option is installed);

DIN EN ISO 12100:2010, DIN EN 474-1:2006+A4:2013, DIN EN 474-5:2006+A3:2013,  
DIN EN ISO 3471:2010, DIN EN ISO 3744:1995, DIN EN ISO 3449:2009

**Authorized representative for the compilation of technical documentation**

Wacker Neuson Linz GmbH  
Flughafenstraße 7  
4063 Hörsching  
Austria

\_\_\_\_\_  
Robert Finzel,  
Managing director

The indications specified above correspond to the existing information at time of going to press. They have possibly changed in the meantime (refer to the original declaration of conformity supplied with the vehicle). Applies to EU countries, and countries with legislation similar to that of the EU. Applies to all vehicles with CE marks that have not been modified without authorization since the product was placed on the market.



---

Notes:

# 1 Foreword

## 1.1 Operator's manual

### Information on this Operator's Manual

The Operator's Manual is stored in the compartment on the left side of the seat.

A document box behind the seat is available as an option.

This operator's manual contains important information on how to work safely, correctly and economically with the vehicle. Therefore, it aims not only at new personnel, but it also serves as a reference for experienced personnel.

Furthermore, the reliability and the service life of the vehicle will be increased by following the instructions in the Operator's Manual. This is why the Operator's Manual must be kept at hand in the vehicle.

The operator must carefully read and understand the Operator's Manual before starting up, servicing or repairing the vehicle.

This Operator's Manual will help to familiarize yourself more easily with the vehicle, thereby enabling you to use it more safely and efficiently.

This Operator's Manual does not include special superstructures.

Please contact your dealer if you require more information on the vehicle or the Operator's Manual.

---

## Explanation of symbols and abbreviations

### Explanation of symbols

- Identifies a list
  - Identifies a subdivision of a list
  - Description of a result
- 1. Identifies an activity  
Follow the order of the activity!
- 2. Continuation of an activity  
Follow the order of the activity!

**A** Identifies an alphabetical list

**B** Continuation of an alphabetical list

Cross references: see page **1-1** (page)

Cross references: **7** (pos. no. or table no.)

Cross-references: *Fig. 2* (Fig. no. 1)

Cross references: – see chapter “5 Operation” on page 5-1  
(see chapter)

Cross references: – see “Operation” on page 5-1 (-see text)

---



### Information

Identifies an information that, when followed, provides for a more efficient and economical use of the vehicle.

---



### Environment

Failure to observe the instructions identified by this symbol can cause damage to the environment.

---




**Abbreviations**

Fig.	=	Figure
AUX	=	Additional control circuit
B	=	Width
o/h	=	Operating hours
approx.	=	approximately
DPF	=	Diesel particulate filter
FGPS	=	Front Guard Protective Structure
FOPS	=	Falling Objects Protective Structure
if nec.	=	if necessary
Hydrau- lic quick- hitch	=	Hydraulic quickhitch (for example Easy Lock)
max.	=	maximum
min.	=	minimum
MSWS	=	Mechanical quickhitch
Pos.	=	Position
hp	=	Stabilizer blade
ROPS	=	Roll Over Protective Structure (without losing contact with the ground)
TOPS	=	Tip Over Protective Structure
e. g.	=	for example



## Glossary

Attachment	All exchangeable equipment (for example buckets) released by Wacker Neuson and developed for work with the machine.
Working lights	The lights on the roof, chassis and boom are referred to as working lights.
Towing	Tow the excavator out of the immediate danger zone (for example railroad crossing or job site).
DOC	Diesel oxidation catalytic converter; removes carbon monoxide and residues of unburned fuel from the exhaust fumes.
DPF	Diesel particulate filter; burns soot particles in the exhaust fumes
Operating company/person	A company (or person) operating the vehicle. This can be a job site operating company, for example.
Operators	Person performing vehicle travel or operation.
Vehicle	Unless otherwise specified, the term “ <b>machine</b> ” refers to the excavator described in this Operator’s Manual. In some cases, the vehicle is also referred to as excavator to avoid confusion with other vehicles.
Machine operation	All work (for example vehicle travel, moving material, daily maintenance) an operator is allowed to or has to perform in connection with the vehicle. The term “ <b>machine operation</b> ” does not include maintenance only a Wacker Neuson service center is allowed to perform.
Lift capacity table	The maximum weight which may be lifted in excavating operations. If the upper carriage is rotated, pay attention to the values of the <b>load diagrams</b> .
Creep gear	Perform vehicle travel as slowly as possible and jerk free.
Hose rupture	Hydraulic oil under pressure escapes from a hydraulic hose.
Check the threaded fittings for tightness	Check the threaded fittings and corresponding components/assemblies visually or manually (without using tools) for tightness. In case of slack screw connections, contact an authorized service center.
Visual aids	Visual aids are, for example, rearview mirrors, cameras, but also persons assisting the operator during machine operation.
Control lever base	The foldable control lever base on the left.

EU Stage III/EPA Tier 4	The vehicles comply with different exhaust-gas standards depending on optional equipment. Engine variants are described separately if there are engine-specific differences (for example regarding operation) – see <i>chapter “Model designations and trade names” on page 3-2.</i>
Load diagram	Specifies the maximum load at a given boom extension with which the upper carriage may be rotated by 360° and the excavator may travel in creep gear with the stabilizer blade raised without tipping over.
Loading weight	The actual weight of the vehicle at the beginning of transportation. This weight refers to vehicles which are equipped exclusively with options approved by Wacker Neuson.
Additional control circuits	Additional control circuits required for certain attachments. <ul style="list-style-type: none"> <li>• AUX I: auxiliary hydraulics (for example for hydraulic hammer or offset bucket)</li> <li>• AUX II: 3rd control circuit (for example for universal grab)</li> <li>• AUX III: for example Powertilt</li> <li>• AUX IV: hydraulic quickhitch (for example Easy Lock)</li> <li>• AUX V: oscillating grab</li> </ul>
Image description	
	Symbolizes a full battery

### Right/left/front/rear

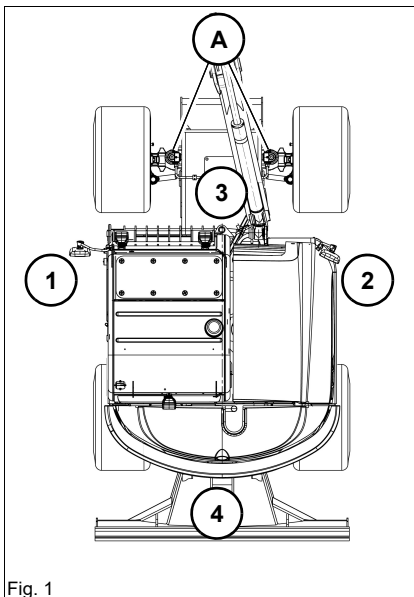


Fig. 1

These terms are used from the view of an operator in the cabin if the front of the cabin faces toward the oscillating-axle cylinders **A**.

- 1: left
- 2: right
- 3: front
- 4: rear

## Target-group definition

This Operator's Manual is intended for professional construction site personnel.

Any operator must have fully read and understood this Operator's Manual completely.

A dealer or person renting the vehicle must instruct the operator and have this confirmed in writing.

## Operator qualification and requirements for safe operation

Among other things, safe vehicle operation depends on the following points:

- Machine model and its outfitting
- Machine maintenance
- Work and driving speed
- Nature of ground and work environment

The most important points are the operator's qualification and power of judgment. A well-trained operator following the Operator's Manual and maintenance plan ensures a long service life and durability of the vehicle.

Specific training enables the operator to acquire, among other things, the following skills:

- Correct assessment of work situations
- Feeling for the vehicle
- Recognition of possible risk situations
- Safe working by making the correct decisions for man, vehicle and the environment

The operator is at risk if the vehicle is not operated correctly.

Follow the operating procedures and instructions described for the vehicle.

Access to the vehicle or vehicle operation is prohibited for children and persons under the influence of alcohol, drugs, or medicine.

**Conversion table**

The rounded imperial values are indicated in brackets, for example 1060 cm<sup>3</sup> (64.7 in<sup>3</sup>).

<b>Volume unit</b>	
1 cm <sup>3</sup>	(0.061 in <sup>3</sup> )
1 m <sup>3</sup>	(35.31 ft <sup>3</sup> )
1 ml	(0.034 US fl.oz.)
1 l	(0.26 gal)
1 l/min	(0.26 gal/min)
<b>Unit of length</b>	
1 mm	(0.039 in)
1 m	(3.28 ft)
<b>Weight</b>	
1 kg	(2.2 lbs)
1 g	(0.035 oz)
<b>Pressure</b>	
1 bar	(14.5 psi)
1 kg/cm <sup>2</sup>	(14.22 lbs/in <sup>2</sup> )
<b>Force/output</b>	
1 kN	(224.81 lbf)
1 kW	(1.34 hp)
1 PS	(0.986 hp)
<b>Torque</b>	
1 Nm	(0.74 ft.lbs.)
<b>Speed</b>	
1 km/h	(0.62 mph)
<b>Acceleration</b>	
1 m/s <sup>2</sup>	(3.28 ft/s <sup>2</sup> )



## 1.2 Warranty and liability

### Exemption from warranty and liability

#### Warranty

Warranty claims can be made only if the conditions of warranty have been observed. They are included in the General Conditions of Sales and Delivery for new vehicles and spare parts sold by the dealers of Wacker Neuson Linz GmbH. Furthermore, all instructions in this Operator's Manual must be observed.

Have the maintenance, delivery inspection and the entries in the service booklet performed by a Wacker Neuson service center, otherwise warranty claims will not be acknowledged.

#### Exemption from liability

- Modifying Wacker Neuson products and fitting them with additional equipment and attachments that are not included in our delivery program requires Wacker Neuson's written authorization, otherwise warranty and product liability for possible damage caused by these modifications shall not be applicable.
- The safety of the vehicle can be negatively affected by performing vehicle modifications without proper authority and by using spare parts, equipment, attachments and optional equipment that have not been checked and released by Wacker Neuson. Warranty and product liability for possible damage caused by these modifications shall not be applicable.
- Wacker Neuson Linz GmbH shall not be liable for injury and/or damage to property caused by failure to observe the safety instructions, warnings and the Operator's Manual, and by the negligence of the duty to exercise due care when:
  - Handling
  - Operating
  - Servicing and performing maintenance
  - Repairing the vehicle. This is also applicable in those cases in which special attention has not been drawn to the duty to exercise due care, in the safety instructions as well as in the Operator's and maintenance manuals.
  - Read and understand the Operator's Manual before starting up, servicing or repairing the vehicle. Observe all safety instructions and warnings.

## 2 Safety

### 2.1 Safety symbols and signal words

#### Explanation

The following symbol identifies safety instructions. It is used for warning against potential personal risk or danger.

---

 **DANGER**

**DANGER identifies a situation causing death or serious injury if it is not avoided.**

Consequences in case of non-observance.

- ▶ Avoidance of injury or death.

---

 **WARNING**

**WARNING identifies a situation that can cause death or serious injury if it is not avoided.**

Consequences in case of non-observance.

- ▶ Avoidance of injury or death.

---

 **CAUTION**

**CAUTION identifies a situation that can cause injury if it is not avoided.**

Consequences in case of non-observance.

- ▶ Avoidance of injury.

---

**NOTICE**

NOTICE identifies a situation that causes damage to the vehicle if it is not observed.

- ▶ Avoidance of damage to property.
-

### 2.2 Qualification of operating personnel

#### Owner's duties

- Only allow specifically authorized, trained and experienced persons to operate, drive and perform maintenance on the vehicle.
- Do not allow persons to be trained or instructed by anyone other than an authorized and experienced person.
- Have persons to be trained or instructed practice under supervision until they are familiar with the machine and its behavior (for example with the steering and braking behavior).
- Access to the vehicle or vehicle operation is prohibited for children and persons under the influence of alcohol, drugs or medicine.
- Clearly and unequivocally define the responsibilities of the operating and maintenance personnel.
- Clearly and unequivocally define the responsibilities on the job site, also in view of traffic regulations.
- Give the operator the authority to refuse safety instructions from third parties.
- Have the vehicle serviced and repaired only by an authorized service center.

#### Required knowledge of the operator

- The operator is responsible for third parties.
- Avoid any operational mode that might be prejudicial to safety.
- The specific national driving license is required.
- The vehicle may only be operated by authorized and safety-conscious persons who are fully aware of the risks involved in operating the vehicle.
- The operator and owner are obligated to operate the vehicle only in a safe and working condition.
- All persons working on or with the vehicle must have read and understood the safety instructions in this Operator's Manual before starting work.
- Follow, and instruct the operator in, legal and other mandatory regulations relevant to accident prevention.
- Observe and instruct the operator in regulations regarding road traffic and environmental protection.
- Use only the defined accesses for getting on and off the vehicle.
- Be familiar with the emergency exit of the vehicle.

## **Preparatory measures for the operator**

- Before starting, check the vehicle whether it can be driven and operated safely.
- Tie back long hair and remove all jewelry.
- Wear close-fitting work clothes that do not hinder movement.

## **2.3 Conduct**

### **Prerequisites for operation**

- The vehicle has been designed and built in accordance with state-of-the-art standards and the recognized safety regulations. Nevertheless its use can cause danger to the operator or third parties, or damage to the vehicle.
- Store this Operator's Manual in the place provided for this in or on the vehicle. Immediately replace a damaged or illegible Operator's Manual and any supplements to it.
- The vehicle must only be operated in accordance with its designated use and the instructions set forth in this Operator's Manual.
- The operator and owner are obligated not to put a damaged or malfunctioning vehicle into operation or operate it.
  - If a damage or malfunction occurs during operation, put the vehicle out of operation immediately and secure it against restart.
  - Have all malfunctions jeopardizing the safety of the operator or third parties immediately repaired by an authorized service center.
- Do not put the vehicle into operation or operate it after an accident; have it inspected for damage by an authorized service center.
  - Have the seat belt replaced by an authorized service center after an accident, even if there is no visible damage.
  - Cabin and protective structures
- Remove all dirt, snow and ice from climbing aids (for example from the handholds, footholds, handrails).
- The owner is responsible for requiring the operating and maintenance personnel to wear protective clothing and equipment as required by the circumstances.



## 2.4 Operation

### Preparatory measures

- Operation is only allowed with correctly installed and intact protective structures.
- Keep the vehicle clean. This reduces injury, accident and fire hazards.
- Safely store objects you carry with you in the places provided for this (for example in the storage compartment, drinks holder).
- Do not carry objects with you that protrude into the user's work space. They can create another danger in case of an accident.
- Observe all safety, warning and information labels.
- Start and operate the vehicle only with the seat belt fastened and only from the place provided for this.
- Check the condition and the fastening of the seat belt. Have malfunctioning seat belts and mounting hardware replaced by an authorized service center.
- Before starting work, adjust the seating position so that all control elements can be reached and fully operated.
- Only make personal settings when the vehicle is at a standstill (e.g. seat, steering column).
- Ensure that all safety devices are properly installed and functional before starting work.
- Before starting work or after interrupting work, ensure that the brake, steering, signaling and light systems are functional.
- Before putting the vehicle into operation, ensure that nobody is in the danger zone.

## Job site

- The operator is responsible for third parties.
- Before starting work, familiarize yourself with the job site. This applies to, for example:
  - Obstacles in the job site and vehicle travel area
  - Any barriers separating the job site from public roads
  - Soil weight-bearing capacity
  - Existing overhead and underground lines
  - Special operating conditions (for example dust, steam, smoke, asbestos)
- The operator must know the maximum dimensions of the vehicle and the attachment – see “Technical data”.
- Maintain a safe distance (for example from buildings, edges of building pits).
- During work in buildings or in enclosed areas, look out for:
  - Height of the ceiling/clearances
  - Width of entries/passages
  - Maximum load of ceilings and floors
  - Sufficient room ventilation (for example risk of carbon monoxide poisoning)
- Use existing visual aids to stay aware of the danger zone.
- In conditions of darkness and poor visibility, switch on existing work lights and ensure that motorists are not blinded by these lights.
- If the existing lights of the vehicle are not sufficient for performing work safely, ensure additional lighting of the job site.
- Due to hot vehicle parts, maintain a safe distance from easily flammable material (for example from hay, dry leaves).

## Danger zone

- The danger zone is the area in which persons are in danger due to the movements of the vehicle, attachment and/or load.
- The danger zone also includes the area that can be affected by falling material, equipment or by parts that are thrown out.
- Extend the danger zone sufficiently in the immediate vicinity of buildings, scaffolds or other elements of construction.
- Seal off the danger zone should it not be possible to keep a sufficient safety distance.
- Stop vehicle operation immediately if persons do not stay clear of the danger zone.



### **Carrying passengers**

- Carrying passengers with the vehicle is PROHIBITED.
- Carrying passengers on/in attachments/tools is PROHIBITED.
- Carrying passengers on/in trailers is PROHIBITED.

### **Mechanical integrity**

- The operator and owner are obligated to operate the vehicle only in a safe and working condition.
- Operate the machine only if all protective and safety-oriented equipment (for example protective structures such as a cabin or rollbar, removable safety devices) is installed and functional.
- Check the vehicle for visible damage and defects.
- In case of damage and/or unusual behavior, put the vehicle out of operation immediately and secure it against restart.
- Have all malfunctions jeopardizing the safety of the operator or third parties immediately repaired by an authorized service center.

### **Starting the engine of the vehicle**

- Start the engine only according to the Operator's Manual.
- Observe all warning and indicator lights.
- Do not use any liquid or gaseous starting aids (for example ether or starting fuel).

## Machine operation

- Start and operate the vehicle only with the seat belt fastened and only from the place provided for this.
- Put the vehicle into operation only if visibility is sufficient (have another person guide you if necessary).
- Operation on slopes:
  - Travel/work only uphill or downhill.
  - Avoid vehicle travel across a slope, observe the vehicle's permissible inclination (and of the trailer if necessary).
  - Keep loads on the uphill side of the vehicle and as close as possible to it.
  - Keep attachments/work equipment close to the ground.
- Adapt the travel speed to the circumstances (for example the ground conditions, weather conditions).
- There is increased danger during backward vehicle travel. Persons in the blind spot of the vehicle cannot be seen by the operator.
  - Ensure that nobody is in the danger zone when you change the travel direction.
- Never get on a moving vehicle and never jump off the vehicle.

## Machine travel on public roads/sites

- The specific national driving license is required.
- Observe the national regulations (for example the road traffic regulations) during machine travel on public roads/sites.
- Ensure that the vehicle is in compliance with the national regulations.
- In order not to blind other motorists, using the existing work lights during vehicle travel on public roads/site is prohibited.
- When crossing underpasses, bridges, tunnels, for example, ensure that the clearance height and width is sufficient.
- The attachment fitted onto the machine must be certified for travel on public roads/sites (see for example the registration documents).
- The attachment fitted onto the vehicle must be empty and in transport position.
- The attachment fitted onto the vehicle must be equipped with the mandatory lights and protective equipment.
- Take measures against unintentional operation of the operating hydraulics.
- If the vehicle has different steering modes, ensure that the mandatory steering mode is selected.



### Stopping the engine of the vehicle

- Stop the engine only according to the Operator's Manual.
- Before stopping the engine, lower the work equipment/attachment to the ground.

### Stopping and securing the vehicle

- Unbuckle the seat belt only after stopping the engine.
- Before leaving the machine, secure it to prevent it from rolling away (for example with the parking brake, suitable wheel chocks).
- Remove the starting key and secure the vehicle against unauthorized operation.

## 2.5 Lifting gear applications

### Requirements

- Have loads fastened and the operator guided by a qualified person who has specific knowledge of lifting gear applications and the usual hand signals.
- The person giving instructions to the operator must stay in visual contact with the operator when fastening, guiding or removing the load (maintain visual contact).
- If this is not possible, ask one more person with the same qualifications to guide.
- The operator may not leave his seat as long as the load is raised.



## **Fastening, guiding and removing loads**

- Follow the applicable specific regulations for fastening, guiding and removing a load.
- Wear protective clothing and equipment when fastening, guiding and removing loads (for example a hard hat, safety glasses, protective gloves, safety boots).
- Do not place lifting and fastening gear over sharp edges or rotating parts. Loads must be fastened so as to prevent them from slipping or falling.
- Move loads only on horizontal, level and firm ground.
- Move loads close to the ground.
- In order to avoid oscillating movements of loads:
  - Perform smooth, slow movements with the vehicle.
  - Use cables to guide the load (do not use hands to guide).
  - Bear in mind the weather conditions (for example the wind force).
  - Keep a minimum safety distance from objects.
- The operator may allow the load to be fastened and removed only if the vehicle and its work equipment are not being moved.
- Danger zones must not overlap with the work zones of other vehicles.



### Lifting gear applications

- The vehicle must be certified for lifting gear applications.
- Observe the national regulations for lifting gear applications.
- Lifting gear applications are procedures involving raising, transporting and lowering loads with the help of lifting and fastening gear.
- The help of an accompanying person is necessary for fastening, guiding and removing the load.
- There must be nobody under the load.
- Stop the vehicle immediately and stop the engine if persons enter the danger zone.
- Use the machine for lifting gear applications ONLY if the mandatory lifting gear (for example a joint rod and load hook) and safety equipment (for example optical and acoustic warning devices, hose burst valve, stability table) is installed and functional.
- Use only lifting and fastening gear certified by a test/certification body, observe the inspection intervals (use only chains and shackles. No belts, slings or cables).
- Do not use any lifting and fastening gear that is dirty, damaged or not of sufficient size.
- Do not interrupt the work process with a load attached.

## 2.6 Trailer operation

### Trailer operation

- The vehicle must be certified for trailer operation.
- Observe the national regulations for trailer operation.
- The specific national driving license is required.
- Carrying passengers on/in trailers is PROHIBITED.
- Observe the maximum permissible vertical and trailer load.
- Do not exceed the permissible trailer speed.
- Trailer operation with the towing gear of the vehicle is prohibited.
- Trailer operation changes the vehicle's operating behavior; the operator must be familiar with this and act accordingly.
- Bear in mind the vehicle's steering mode and the trailer's turning circle.
- Before hitching/unhitching the trailer, secure it to prevent it from rolling away (for example with the parking brake, suitable wheel chocks).
- There must be nobody between the vehicle and the trailer when hitching a trailer.
- Hitch the trailer onto the vehicle correctly.
- Ensure that all equipment works correctly (for example the brakes, lights).
- Before starting vehicle travel, ensure that nobody is between the vehicle and the trailer.

## 2.7 Attachment operation

### Attachments

- Use only attachments that are certified for the machine or its protective equipment (for example a shatter protection).
- All other attachments require the vehicle manufacturer's release.
- The danger zone and the work zone depend on the attachment used – see the Operator's Manual of the attachment.
- Secure the load.
- Do not overload attachments.
- Check the correct position of the lock.



### Operating

- Carrying persons on/in an attachment is prohibited.
- Installing a work platform is prohibited.
  - Exception: The vehicle is certified and equipped with the necessary safety equipment.
- Attachments and counterweights modify handling, as well as the steering and brake capability of the vehicle.
- The operator must be familiar with these modifications and act accordingly.
- Before starting work, operate the attachment to check that it works correctly.
- Before putting the attachment into operation, ensure that nobody is in danger.
- Lower the attachment to the ground before leaving the seat.

### Removing and fitting attachments

- Before uncoupling or coupling hydraulic connections:
  - Stop the engine.
  - Release the pressure in the operating hydraulics
- Picking up and lowering attachments to the ground requires special care:
  - Pick up and safely lock the attachment in accordance with the Operator's Manual.
  - Lower the attachment only to firm, level ground and secure it to prevent it from tipping over or rolling away.
- Put the vehicle and the attachment into operation only if:
  - The protective equipment has been installed and is functional.
  - The connections for the lights and the hydraulic system have been established and are functional.
- Perform a visual check of the lock after locking the attachment.
- There must be nobody between the vehicle and the equipment when picking up or lowering an attachment to the ground.

## 2.8 Towing, loading and transporting

### Towing

- Seal off the danger zone.
- Ensure that no one is near the towing bar or cable. The safety distance is equal to 1.5 times the length of the towing equipment.  
Use a towing cable for vehicles with a total weight of up to 4.0 tons.  
Use a towing bar for vehicles with a total weight of over 4.0 tons.
- Observe the mandatory transport position, permissible speed and itinerary.
- A tractor vehicle of the same weight category must be used as a minimum. Furthermore, the tractor vehicle must be equipped with a safe braking system and sufficient tractive power.
- Use only towing bars or cables certified by a test/certification body, observe the inspection intervals.
- Do not use any towing bars or cables that are dirty, damaged or not of sufficient size.
- Fasten towing bars or cables only at the defined points.
- Tow away only in accordance with this Operator's Manual to avoid damage to the vehicle.
- Observe the national regulations (for example the light regulations) when towing on public roads/sites.



### Crane-lifting

- Seal off the danger zone.
- The crane and the lifting gear must have suitable dimensions.
- Observe the vehicle's overall weight – see "Technical data".
- Wear protective clothing and equipment when fastening, guiding and removing the machine (for example a hard hat, safety glasses, safety boots).
- Use only lifting and fastening gear certified by a test/certification body (for example cables, belts, hooks, shackles), observe the inspection intervals.
- Do not use any lifting and fastening gear that is dirty, damaged or not of sufficient size.
- Perform a visual check to ensure that all slinging points are neither damaged nor worn (no widening, no sharp edges, no cracks).
- Have loads fastened and crane operators only guided by experienced persons.
- The person guiding the crane operator must be within sight or sound of him.
- Observe all movements of the vehicle and lifting gear.
- Secure the vehicle against unintentional movement.
- Raise the vehicle only after it is safely attached and the person attaching the vehicle has given his approval.
- Use only the slinging points provided for fastening the lifting gear (for example cables, belts).
- Do not attach the machine by twining the lifting gear (for example cables, belts) around it.
- Ensure an even load distribution (center of gravity!) when fastening the lifting gear.
- Ensure that no one is in, on or under the vehicle when loading the vehicle.
- Observe the national regulations (for example "Merkheft Erdbau-maschinen", leaflet on earth moving machines of the German employers' liability insurance association for construction engineering).
- Load the vehicle only in accordance with this Operator's Manual to avoid damage to the vehicle.
- Do not raise a machine that is stuck or frozen onto the ground, for example.
- Bear in mind the weather conditions (for example the wind force, visibility conditions).

## Transportation

- For the safe transportation of the vehicle:
  - The transport vehicle must have a sufficient load capacity and platform – see “Technical data”
  - The maximum weight rating of the transport vehicle must not be exceeded.
- Use only lifting and fastening gear certified by a test/certification body, observe the inspection intervals.
- Do not use any lifting and fastening gear that is dirty, damaged or not of sufficient size.
- In order to secure the vehicle on the platform, use only the fastening points provided for this purpose.
- Ensure that nobody is in or on the vehicle during transportation.
- Observe the national regulations (for example “Merkheft Erdbau-maschinen”, leaflet on earth moving machines of the German employers’ liability insurance association for construction engineering).
- Bear in mind the weather conditions (for example ice, snow).
- Ensure the minimum load on the steering axle(s) of the transport vehicle, and ensure an even load distribution.

## 2.9 Maintenance

### Maintenance

- Observe the intervals prescribed by law and those specified in this Operator’s Manual for routine checks/inspections and maintenance.
- For inspection and maintenance, ensure that all tools and service center equipment are adapted to the performance of the task described in this Operator’s Manual.
- Do not use any damaged or malfunctioning tools.
- The vehicle and the engine must be stopped during maintenance.
- Once maintenance is over, correctly install safety equipment again that has been removed.
- Wait for the vehicle to cool down before touching components.



### Personal safety measures

- Avoid any operational mode that might be prejudicial to safety.
- Wear protective clothing and equipment (for example a hard hat, protective gloves, safety boots).
- Tie back long hair and remove all jewelry.
- If maintenance on a running engine cannot be avoided:
  - Only work in groups of two.
  - Both persons must be authorized and trained for the operation of the vehicle.
  - One person must be seated on the seat and stay in contact with the second person.
  - Keep a safe distance from rotating parts (for example from fan blades, belts).
  - Keep a safe distance from hot parts (for example from the exhaust system).
  - Perform maintenance only in well-ventilated rooms or rooms with an exhaust-gas suction system.
- Safely lock/support vehicle components before starting work.
- Apply special care when working on the fuel system due to the increased fire hazard.

## Preparatory measures

- Attach a warning label to the control elements (for example “Machine being serviced, do not start”).
- Before performing assembly work on the vehicle, support the areas to be serviced and use suitable lifting and supporting equipment for the replacement of parts over 9 kg (20 lbs).
- Perform maintenance only if:
  - the vehicle is positioned on firm and level ground
  - the machine is secured to prevent it from rolling away (for example with the parking brake, wheel chocks), and if all attachments/the work equipment is lowered to the ground
  - the engine is stopped
  - the starting key has been removed
  - the pressure in the operating hydraulics has been released
- If maintenance has to be performed under a raised machine/attachment, support the machine/attachment (for example with a lift platform, trestles) ensuring safety and stability.
- Hydraulic cylinders or jacks alone do not sufficiently secure a raised vehicle/attachment.

## Measures for performing maintenance

- Perform only the maintenance described in this Operator’s Manual.
- All work that is not described in this Operator’s Manual must be performed by qualified and authorized technical personnel.
- Follow the maintenance plan – see “Maintenance plan”.
- Always use specially designed or otherwise safety-oriented ladders and working platforms to perform overhead maintenance. Do not use vehicle parts or attachments as a climbing aid.
- Do not use attachments/work equipment as a lift platform for persons.
- Remove all dirt, snow and ice from climbing aids (for example from the handholds, footholds, handrails).
- Disconnect the negative terminal of the battery before working on the electrical system.

### Modifications and spare parts

- Do not modify the machine and the work equipment/attachment (for example the safety equipment, lights, tires, straightening and welding work).
- Modifications must be approved by the manufacturer and performed by an authorized service center.
- Use only original spare parts.

### Protective structures

- The cab, rollbar and protective grate are tested protective structures and may not be changed (e.g. no drilling, bending, welding).
- Perform a visual check according to the maintenance plan (for example check fastenings for damage).
- If damage or defects are detected, have them immediately checked and repaired by an authorized service center.
- Have retrofitting work only performed by an authorized service center.
- Replace self-locking fasteners (for example self-locking nuts) by new ones after removing them.

## 2.10 Measures for avoiding risks

### Tires

- Have repair work on the tires only performed by trained technical personnel.
- Check the tires for correct pressure and visible damage (for example cracks, cuts).
- Tighten the wheel nuts to the specified tightening torque. (See chapter 7.18 Tires/tracks).
- Use only approved tires.
- The machine must have identical tires (for example profile, revolutions per mile).

### Tracks

- Repair work on tracks may be performed only by trained technicians.
- Check the tracks for correct tension and visible damage (for example cracks, cuts).
- Proceed with extreme care on slippery ground (for example on steel plates, ice), increased slipping hazard.
- Use only approved tracks.

## Hydraulic and compressed-air system

- Check all lines, hoses and screw connections regularly for leaks and visible damage.
- Splashed oil can cause injury and fire.
- Leaking hydraulic and compressed-air lines can cause the full loss of the brake effect.
- Have damage and leaks immediately repaired by an authorized service center.
- Check the hydraulic hose in the recommended interval and get it changed.

## Electrical system

- Use only fuses with the specified current rating.
- In case of damage or malfunction in the electrical system:
  - Put the vehicle out of operation immediately and secure it against restart
  - Disconnect the battery or operate the battery master switch
  - Have the malfunction repaired
- Ensure that work on the electrical system is only performed by trained technical personnel.
- Have the electrical system checked regularly and malfunctions repaired immediately (for example loose connections, scorched cables).
- The operating voltage of machine, the attachment and the trailer must be the same (for example 12 V).



### Battery

#### California proposal 65

---

#### **WARNING**

Batteries, battery poles, terminals and corresponding accessory parts contain lead and its compounds and other chemicals that, according to the state of knowledge of the state of California, cause cancer, birth defects or reproductive harm. Wash your hands after use.

---

#### **WARNING**

Cancer and Reproductive Harm - [www.P65Warnings.ca.gov](http://www.P65Warnings.ca.gov).

---

- Batteries contain caustic substances (for example sulfuric acid). When handling the battery observe the specific safety instructions and regulations relevant to accident prevention.
- A volatile oxyhydrogen mixture forms in batteries during normal operation and especially during charging. Always wear gloves and eye protection when working with batteries.
- Do not perform battery maintenance near open flames.
- Perform battery maintenance only in well-ventilated areas (for example due to vapors harmful to health, explosion hazard).
- Starting the vehicle with battery jumper cables is dangerous if performed improperly. Observe the safety instructions regarding the battery.

---

**Safety instructions regarding internal combustion engines****California proposal 65**

---

 **WARNING**

The engine exhaust fumes of this product contain chemicals that, according to the state of knowledge of the state of California, cause cancer, birth defects or reproductive harm.

---

 **WARNING**

Diesel engine exhaust fumes and some of its components cause, according to the state of knowledge of the state of California, cancer, birth defects or reproductive harm.

---

 **WARNING**

Cancer and Reproductive Harm - [www.P65Warnings.ca.gov](http://www.P65Warnings.ca.gov).

---

- Internal combustion engines present special hazards during operation and fueling.
- Failure to follow the warnings and safety instructions can cause serious injury or death.
- Keep the area around the exhaust system free of flammable materials.
- Check the engine and fuel system for leaks (for example loose fuel lines). Don't start or let the engine run in case of leaks.
- Breathing the exhaust fumes causes death very quickly.
- Engine exhaust contains gases you cannot see or smell (for example carbon monoxide and dioxide).
  - Never operate the machine in enclosed premises or areas (for example in pits), if there is no suitable ventilation (for example exhaust-gas filters, suction systems).
- Do not operate the vehicle in potentially explosive areas.
- Do not touch the engine, exhaust system and cooling system as long as the engine is still running or has not cooled down yet.
- Do not remove the radiator cap when the engine is running or hot.
- The coolant is hot, under pressure and can cause serious burns.



### **Bleeding the fuel system and refueling**

- Do not bleed the fuel system or refuel near open flames.
- Bleed the fuel system and refuel only in well-ventilated areas (for example due to vapors harmful to health, explosion hazard).
- Wipe away fuel spills immediately (for example due to fire hazard, slipping hazard).
- Firmly close the fuel tank cap; replace a malfunctioning fuel tank cap.

### **Handling oil, grease and other substances**

- When handling oil, grease and other chemical substances (for example the battery acid, coolant), observe the safety data sheets.
- Wear appropriate protective equipment (for example protective gloves, safety glasses).
- Be careful when handling hot consumables – burn hazard.
- In polluted environment (dust, vapors, smoke, asbestos), work only with appropriate personal protective equipment (for example with a breathing mask).
- Do not operate the vehicle in radioactively, biologically or chemically contaminated areas.

### **Fire hazard**

- Fuel, lubricants and coolants are flammable.
- Do not put the vehicle into operation if there is a fire hazard.
- Do not use flammable detergents.
- Keep the area around the exhaust system free of flammable materials.
- Due to hot vehicle parts, maintain a safe distance from easily flammable material (for example from hay, dry leaves).
  - Stop and park the vehicle only in fire-protected areas.
- If the vehicle is equipped with a fire extinguisher, have it installed in its specific location.
- Keep the vehicle clean to reduce the fire hazard.

### **Working near electric supply lines**

- Before performing any work, the operator must check whether there are any electrical supply lines in the designated working area.
- If there are electrical supply lines, only a vehicle with cab may be used (Faraday cage).
- Keep a safe distance from existing electric supply lines.
- If this is not possible, the operator must initiate other safety measures in agreement with the owner or operator of the supply lines (e.g. shutdown the power).
- If supply lines are exposed, they must be fastened, supported and secured accordingly.
- If live supply lines are touched nevertheless:
  - Do not leave/touch the cab (Faraday cage)
  - If possible, drive the vehicle out of the danger zone
  - Warn others against approaching and touching the vehicle
  - Have the live wire de-energized
  - Do not leave the vehicle until the supply lines that have been touched or damaged have been safely de-energized.

### **Working near non-electric supply lines**

- Before performing any work, the operator must check whether there are any non-electrical supply lines in the designated working area.
- If non-electrical supply lines exist, the operator must initiate safety measures in agreement with the owner or operator of the supply lines (e.g. shutdown the supply line).
- If supply lines are exposed, they must be fastened, supported and secured accordingly.



### Behavior during thunderstorm

- Stop machine operation if a thunderstorm is gathering, stop the machine, secure and leave it, and avoid being near it.

### Noise

- Observe the noise regulations (for example, during applications in enclosed premises).
- Bear in mind external sources of noise (compressed-air hammer, concrete saw).
- Do not remove the sound baffles of the machine/attachment.
- Have damaged sound baffles immediately replaced (for example, an insulating mat, muffler).
- Before starting work, get informed on the noise level of the machine/attachment (for example on the adhesive label) – wear ear protectors.
- Do not wear ear protectors during machine travel on public roads/sites.

### Cleaning

- Risk of injury from compressed air and high-pressure cleaners.
  - Wear appropriate protective clothes.
- Do not use any dangerous and aggressive detergents.
  - Wear appropriate protective clothes.
- Operate the machine only in a clean condition.
  - Remove all dirt, snow and ice from climbing aids (for example from the handholds, footholds, handrails).
  - Keep the cabin glazing and visual aids clean.
  - Keep the light system and reflectors clean.
  - Keep the control elements and indicators clean.
  - Keep the safety, warning and information labels clean, and replace damaged and missing labels by new ones.
- Perform cleaning work only if the engine is stopped and cooled down.
- Bear in mind sensitive components and protect them accordingly (for example electronic control units, relays).

### 3 Introduction

#### 3.1 Machine overview



Pos.	Description	Pos.	Description
1	Stabilizer blade	10	Engine cover
2	Chassis	11	Boom
3	Tires	12	Transport bar for clamshell bucket
4	Tool kit	13	Triple articulation boom (option)
5	Mirrors	14	Shovel arm
6	Chassis working lights	15	Bucket
7	Rocker cover	16	Cab
8	Rotating beacon (option)	17	Exhaust
9	Auxiliary hydraulics	18	Roof lights (option)

## Model designations and trade names

Machine model	Trade name	Engine
E14-02	EW65	Perkins 404D-22T
		Perkins 404F-22T
		Perkins 404F-E22TA
		Perkins 404J-E22T

## 3.2 Brief description of the vehicle

The Wacker Neuson model E14 excavators are self-propelled work machines.

These vehicles are powerful, highly flexible and efficient construction vehicles with minimum environmental impact. They are mainly used for loosening and moving earth, for example for digging and filling up construction pits. A wide range of attachments offers a large number of applications, for example hammer operation or bulk-material handling with a grab.



### Information

The machine can be equipped with the **Telematic** option (for transmitting operating data, location, etc. via satellite).

**Cabin**

The cabin has been specially designed for protection in case of an accident.

- ROPS/TOPS tested cabin.
- Standard protective FOPS structure (category I) integrated in cabin
- Protective FOPS structure category II (option) for driver' cabin; Protective structure against falling objects.
- Front guard category II (option) for driver's cabin; Protective structure to guard against objects from the front (e.g. pipes, tree roots).

**Definition of FOPS/Front Guard categories****Category I (FOPS):**

Protection against small falling (FOPS) objects (for example bricks, small pieces of concrete, tools) for vehicles which are used for tasks such as road repair, landscaping work and work on other construction sites.

**Category II (FOPS/Front Guard):**

Protection against heavy falling objects (FOPS) or heavy objects penetrating into the cabin from the front (Front Guard), for example trees or pieces of rock, for machines that are used for tasks such as clearance, demolition and forestry work.

### 3.3 Information and regulations on use

#### Designated use

The vehicle is intended for:

- Moving earth, gravel or rubble, for hammer and grab operation as well as for
- Working only with the attachments indicated in chapter *Technical data of attachments on page 9-15*.
- Every other use is regarded as not designated for the use of the vehicle. Wacker Neuson will not be liable for damage resulting from use other than mentioned above. The user/operating company alone will bear the risk.

Designated use also includes observing the instructions set forth in the Operator's Manual and observing the maintenance and service conditions.

- In applications with lifting gear, the machine is used according to its designated use only if the mandatory devices are installed and functional!
- Use the quickhitch only with the corresponding attachments.
- A restricted work range applies to work with attachments (for example hammer) that can cause fragments to fly around.

**Earth moving machinery on public roads (Austria as an example)**

Earth moving machines may be used on public roads only if they are equipped according to the road traffic regulations of your country.

**Equipment**

Austrian road traffic regulations, for example §53 StVO, require to have the following equipment on board:

- A warning vest according to ÖNORM EN 471
- An approved warning triangle
- An approved warning light
- A first-aid kit in accordance with DIN 13 164 sheet 1 as a minimum

**Machine inspections**

All employer's liability insurance associations require a safety-specific inspection of the machine according to VBG 40 §50, which must be performed once a year by an expert (test report).

In addition, an inspection tag must be affixed to the machine to remind the user when the next inspection by an expert is due.

Observe the legal regulations of your country for recurrent inspections.

**On-board documents**

- Driving license
- Test report according to VBG 40 §50

**Driving license**

Earth moving machinery may be driven on public roads only if the user has a driving license as stipulated by national road traffic regulations for a specific machine.



### 3.4 Labels

---

 **WARNING**

**Injury hazard due to missing or damaged labels!**

An insufficient warning of dangers can cause serious injury or death.

- ▶ Do not remove warning and information labels.
  - ▶ Immediately replace damaged warning and information labels.
- 

---

 **Information**

Type, quantity, and position of the labels depend on options, country and vehicle.

---

## Type labels



Fig. 3 (symbolic representation)

The vehicle type label is located at the right hand side of the vehicle, behind the swiveling console.

### Serial number

The serial number is stamped on the vehicle chassis. It is also located on the type label.

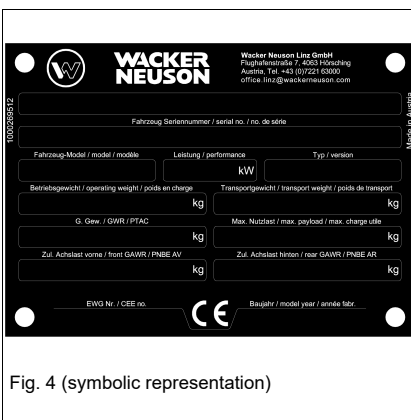


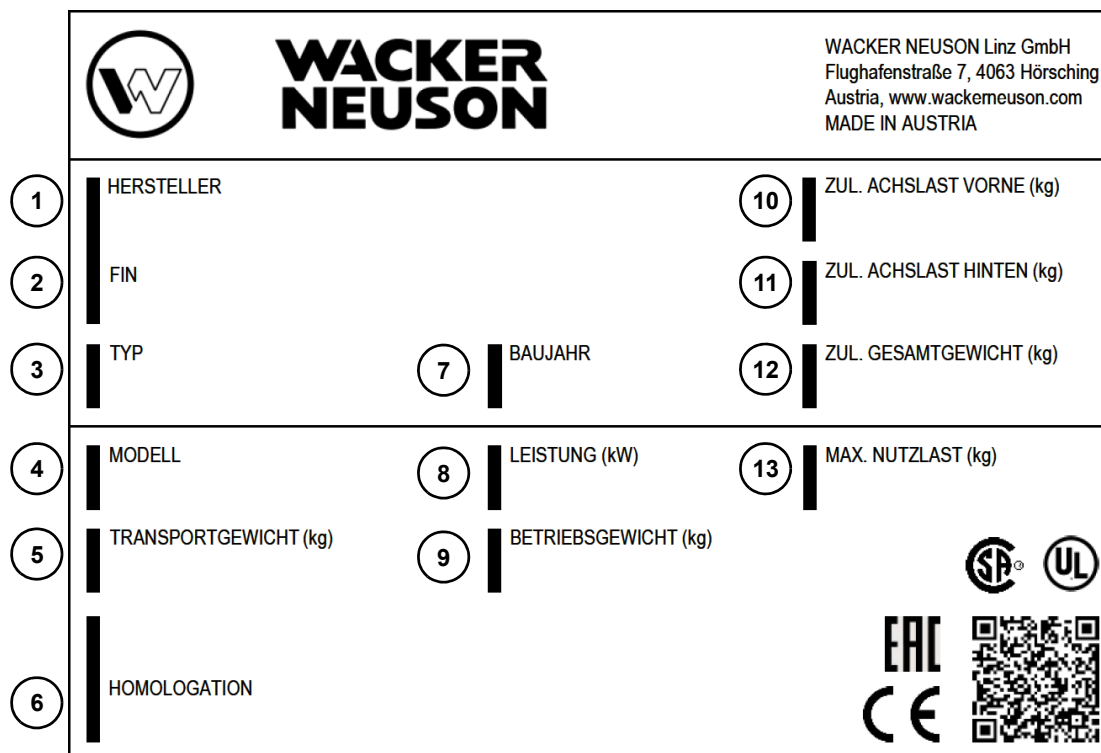
Fig. 4 (symbolic representation)

### Type label (version 1)

The vehicle type label contains the following information:

Description of attachment	HYDRAULIC EXCAVATOR
Vehicle serial no. /serial no.	Machine serial number
Fahrzeug Modell/model/modèle:	Machine designation
Leistung/performance:	Engine power
Typ/version:	Machine type
Betriebsgewicht/operating weight/poids en charge:	Operating weight
Transportgewicht/transport weight/poids en transport:	Transport weight
G. weight/GWR/PTAC:	Gross weight rating (permissible)
Max. Nutzlast/max. payload/max. charge utile:	Maximum payload
Zul. Achslast vorne/front GAWR/PNBE AV:	Front gross axle weight rating
Zul. Achslast hinten/rear GAWR/PNBE AR:	Rear gross axle weight rating
EWG Nr./CEE no.:	EEC check number
Baujahr/model year/année fabr.:	Year of construction

Type label (version 2)



Number	Type label
1	Manufacturer
2	Machine serial number
3	Internal model designation
4	Trade name
5	Transport weight
6	Certification
7	Year of construction
8	Power
9	Operating weight
10	Front gross axle weight rating
11	Rear gross axle weight rating
12	Permissible maximum weight
13	Maximum payload

**i** Information

The type label is bright for better legibility. The language on the type label may vary.



**17-digit serial number**

The 17-digit serial number has additional information, in order to make vehicle identification easier.

**Version 1:**

Manufacturer code	Machine model	Internal model designation	Check letter	Production site	Serial number
WNC	E (Excavator)	1301	K	PAL	12345
	D (Dumper)				
	A (Unit)				
	S (Skid steer loader)				

**Variant 2:**

Manufacturer code	Machine model	Internal model designation	Check letter	Serial number
WNC (Austria) WNP (China)	E (Excavator)	1301	K	00012345
	D (Dumper)			
	A (Unit)			



**Information**

Wacker Neuson components (for example Easy Lock, tilt bucket, rollbar) have numeric serial numbers only.

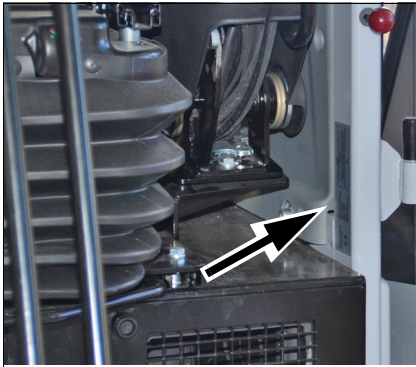


Fig. 5

**Cabin number**

The type label is located on the B pillar on the left.

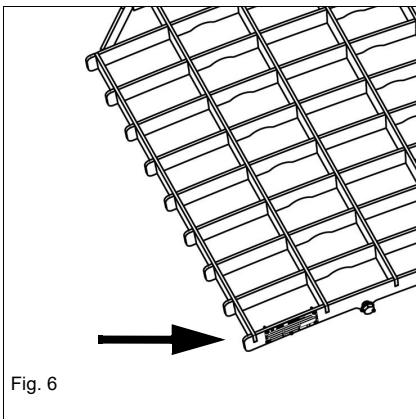


Fig. 6

**FOPS screen type label**

The type label is located at the front left on the chassis.

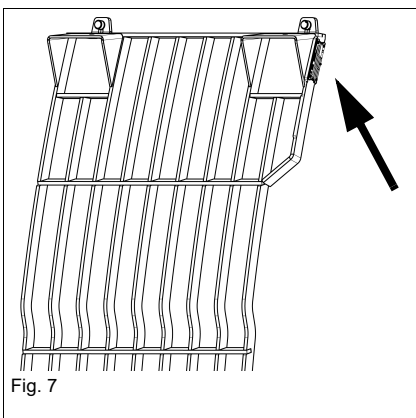


Fig. 7

**Front Guard type label**

The type label is located at the upper left of the chassis.

Warning labels

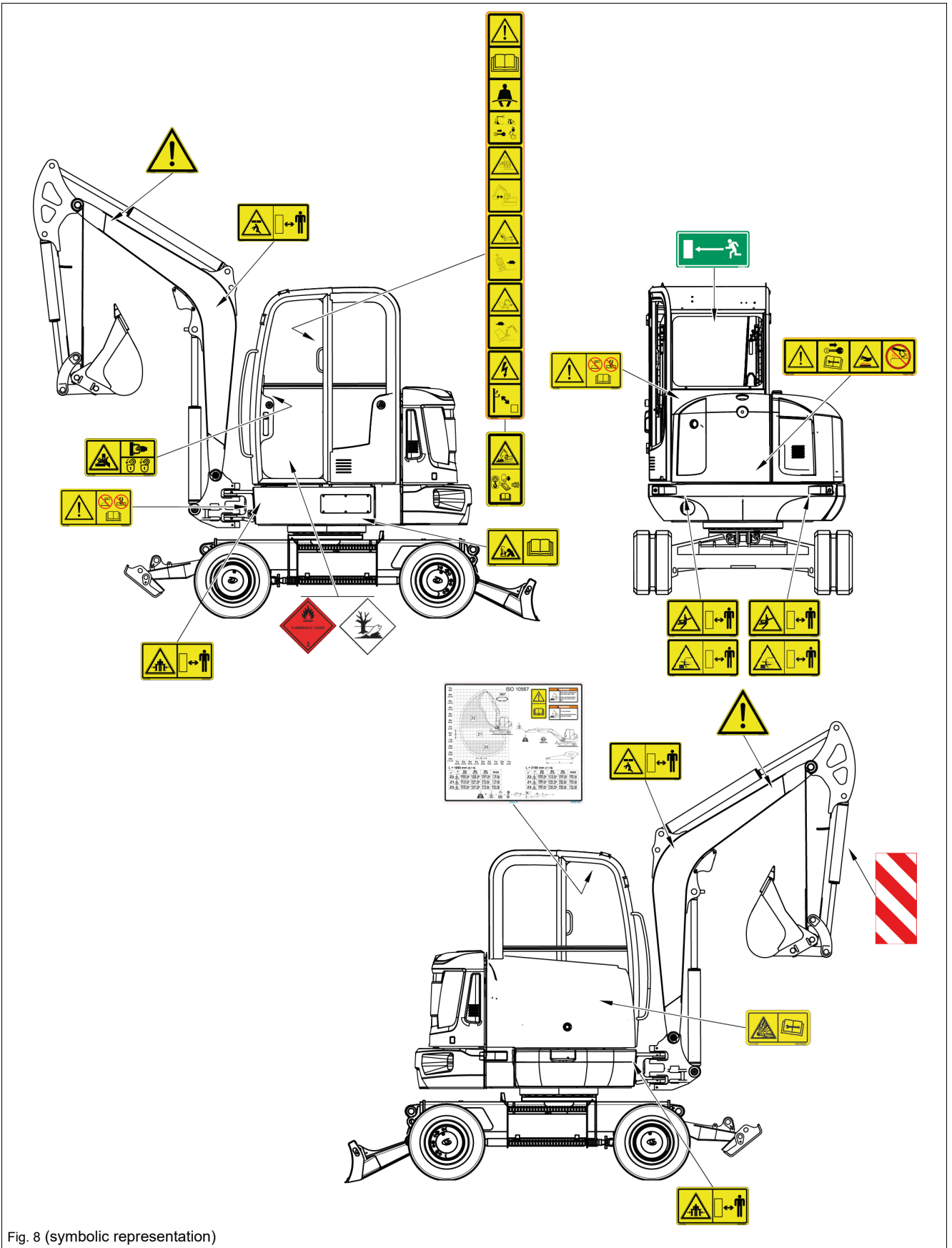


Fig. 8 (symbolic representation)

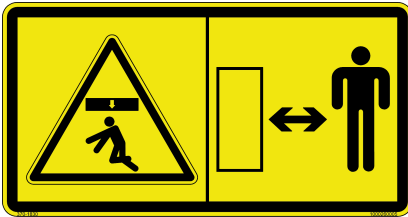


Fig. 9

**Meaning**

Crush Hazard

All persons must stay clear of a raised load or of the danger zone.

**Position**

On the left and right side on the lifting arm

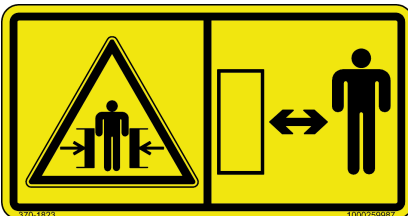


Fig. 10

**Meaning**

Crush Hazard

Do not allow anyone to stay in the danger zone of the vehicle.

**Position**

At the front left and right of the chassis



Fig. 11

**Meaning**

Explosion hazard due to wrong connection of battery jumper cables.

**Position**

Next to the battery

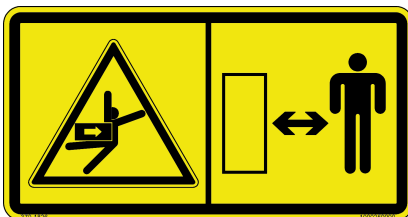


Fig. 12

**Meaning**

Crush Hazard

Do not allow anyone to stay in the swiveling range of the vehicle.

**Position**

On the left and right side of the engine hood

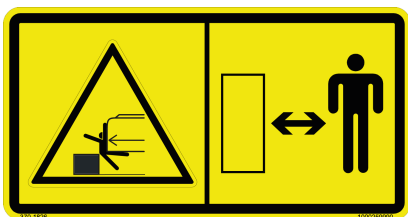


Fig. 13

**Meaning**

Crush Hazard

Do not allow anyone to stay in the swiveling range of the vehicle.

**Position**

On the rear weight left and right

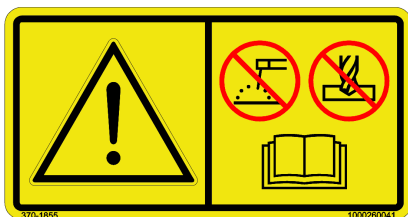


Fig. 14

**Meaning**

Modifications to the structure (for example welding, drilling), retrofitting, and incorrect repairs affect the protective effect of the cabin and can cause serious injury and even death.

**Position**

On the rear left of the cabin

**Alternative Position**

At middle front of chassis



Fig. 15

**Meaning**

Crush Hazard

1. Use the handholds for opening and closing the front window.
2. Lock the window into place.

**Position**

On the window wiper motor

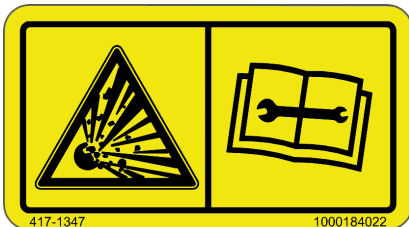


Fig. 16

**Meaning**

Accumulator is under high pressure. Maintenance or repair work may be performed only by a Wacker Neuson service center.

**Position**

Under the valve cover

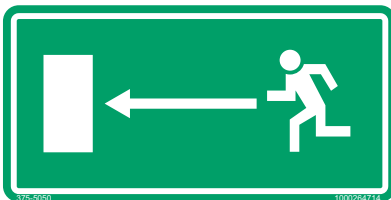


Fig. 17

**Meaning (option)**

 Emergency exit if equipped with **Front Guard** option

**Position**

Inside the cabin on the rear window

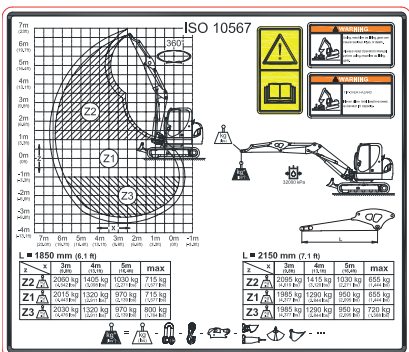


Fig. 18

**Meaning (option)**

Load diagram

**Position**

On the headliner



Fig. 19

**Meaning**

Read the Operator's Manual before starting the vehicle.

Fasten your seat belt.

Lower the boom and the stabilizer blade to the ground.

Remove the starting key and carry it with you.

Raise the control lever base.

**Crush Hazard**

Possible serious vehicle damage.

Keep a safe distance from the cabin.

**Crush Hazard**

Possible serious vehicle damage.

During vehicle operation on slopes, pay attention to the maximum gradient angle and maximum lateral angle of inclination.

Do not drive in speed range 2.

Risk of fatal injuries due to electric shock

During vehicle operation, maintain a safe distance from overhead electric lines.

**Position**

On the B pillar on the left



Fig. 20

**Meaning (option)**

Switch on the safe load indicator during lifting gear applications.

A vehicle can cause serious injury or death if it tips over.

Possible serious vehicle damage

Read and understand the Operator's Manual.

**Position**

On the B pillar on the left



Fig. 21

**Meaning**

Read the Operator's Manual before starting the vehicle.

Remove the starting key and carry it with you.

Injury hazard due to rotating parts

- Open the engine cover only at engine standstill.

Burn hazard due to hot surfaces.

- Let the engine cool down.

Burn hazard due to hot fluid.

Injury hazard due to fluid escaping under pressure.

- Let the engine cool down.
- Release the pressure in the hydraulic system, then open the locks carefully.

**Position**

On the engine cover

**Meaning**

Burn hazard due to hot surfaces (lines, plug connections, screw connections, hydraulic cylinders, couplings, etc.)

**Position**

On the boom on the left and right



Fig. 22

**Meaning**

Environmentally hazardous substances (A)

Easily flammable fluids (B)

The tank and fuel lines contain diesel fuel according to the ADR guidelines (European Agreement concerning the International Carriage of Dangerous Goods by Road).

**Position**

On the travel gear on the left

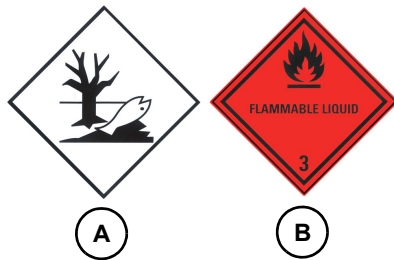


Fig. 23

**Meaning**

Optical warning system

**Position**

On the bucket ram



Fig. 24

Information labels

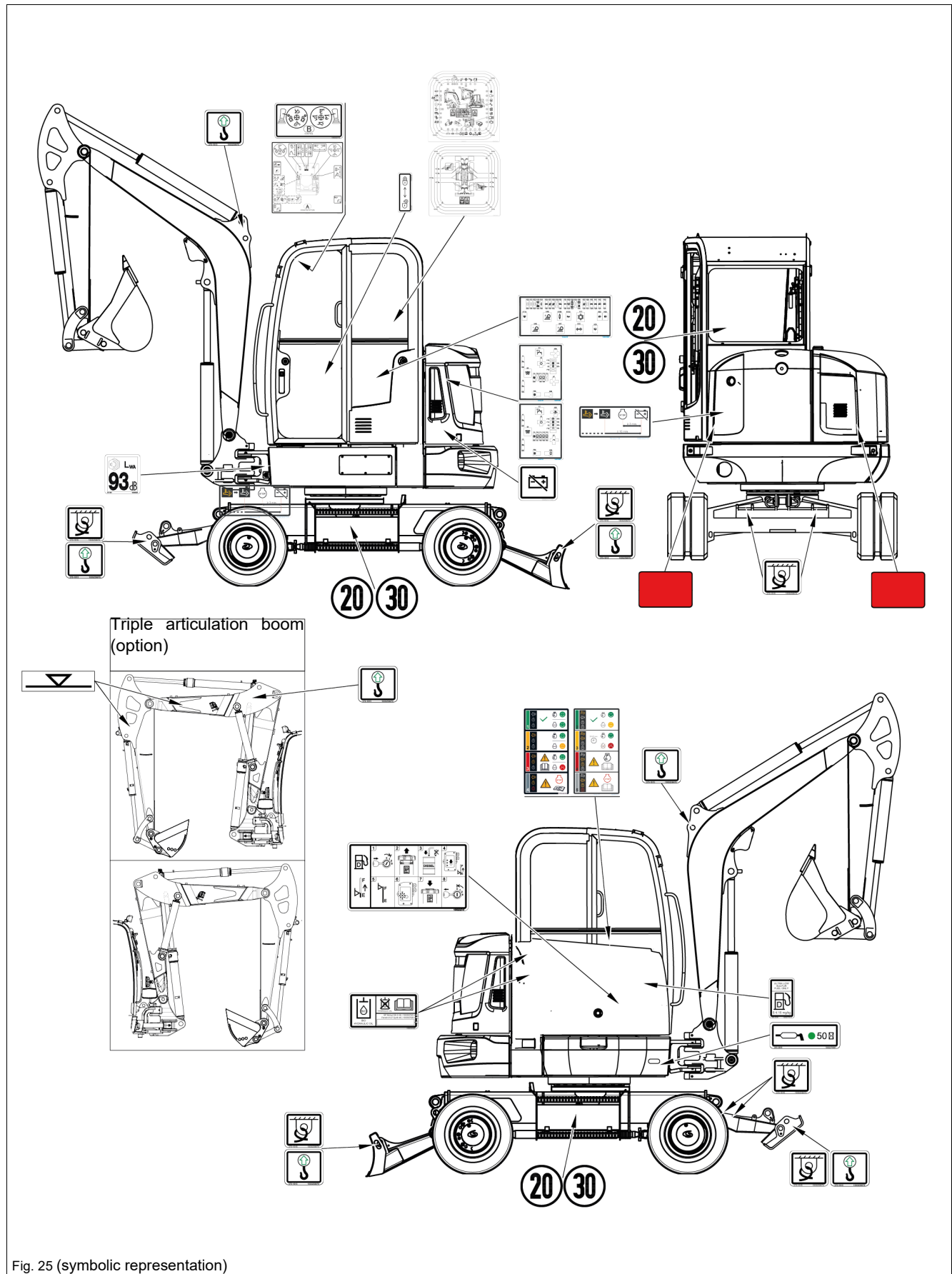


Fig. 25 (symbolic representation)



Fig. 27

**Meaning**

Only refuel with diesel fuel with a sulfur content of < 15 mg/kg (= 0.0015%).

**Position**

Next to the fuel tank filler inlet

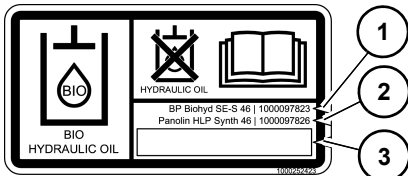


Fig. 28

**Meaning (option)**

The reservoir contains biodegradable hydraulic oil.

This label is notched on the side depending on the biodegradable hydraulic oil used.

1. BP Biohyd SE-S 46
2. Panolin HLP Synth 46
3. Other biodegradable hydraulic oil

**Position**

Next to the filler neck of the hydraulic oil tank

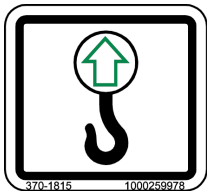


Fig. 29

**Meaning**

Lifting eyes

**Position**

One-piece boom: right and left side, near lifting eye.

Triple articulation boom: left side, near articulated joint

Stabilizer blade: outside left and right

Parallel stabilizer blade: left and right farther toward the inside

Stabilizer legs: one lifting eye each



Fig. 30

**Meaning**

Tie-down points

**Position**

Front travel gear: 2

Rear travel gear: 2

**i Information**

There are no tie-down points on the stabilizer blades or stabilizer legs.

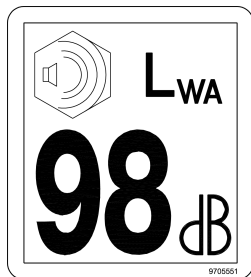


Fig. 31 (symbolic representation)

**Meaning**

Indication of sound power level produced by the vehicle.

$L_{WA}$  = sound power level

Engine	Sound power level
404D-22T	97 dB
404F-22T	98 dB
404F-E22TA	99 dB
404J-E22T	97dB

**Position**

At the front left of the chassis

**Meaning**

Lubrication interval

**Position**

On the right side of the chassis

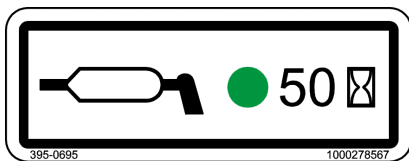


Fig. 32

**Meaning**

Hydraulic functions active or locked.

**Position**

On control lever base

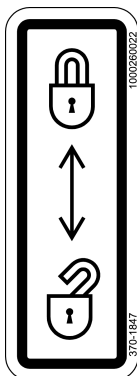


Fig. 33

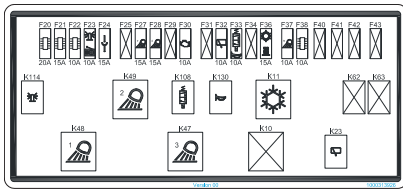
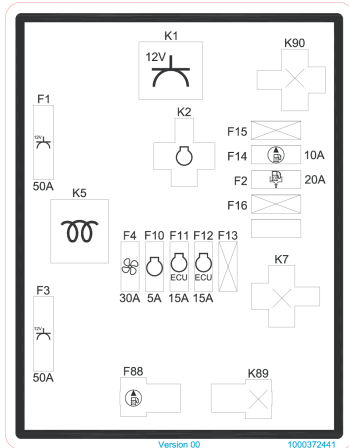
**A****B****Meaning**Cabin relays and fuses **(A)**Engine compartment relays and fuses **(B)****Position****A:** on the outside of the fuse box cover**B:** on the partition wall in the engine compartment

Fig. 34 (symbolic representation)

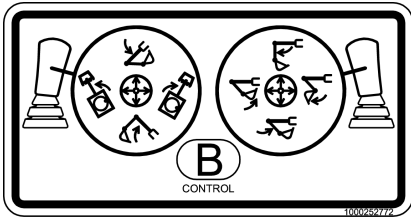


Fig. 35

**Meaning (option)**

Operating procedures differing from the ISO controls if the SAE controls are set.

**Position**

On the roof window on the right

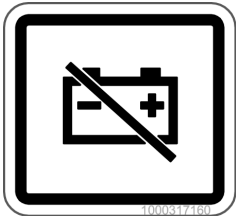


Fig. 36

**Meaning**

Battery master switch

**Position**

At battery master switch

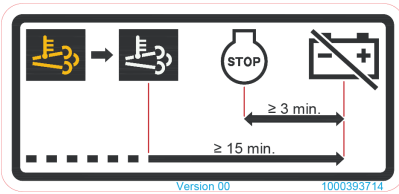


Fig. 37

**Meaning**

Battery battery master switch waiting time

**Position**

In the engine compartment on the left



Fig. 38 (symbolic representation)

**Meaning**

Design-specific speed of the vehicle

**Position**

On the left and right of the tool kit and on the rear window



Fig. 39

**Meaning (option)**

Alignment marks for the triple boom

**Position**

On the left of the triple boom and on the stick

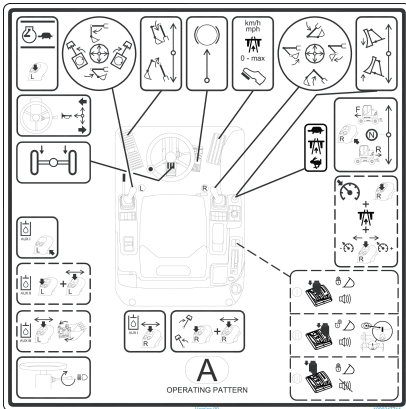


Fig. 40

**Meaning**

Functional overview (ISO controls).

Check the selected control mode before starting the vehicle.

**Position**

On the roof window

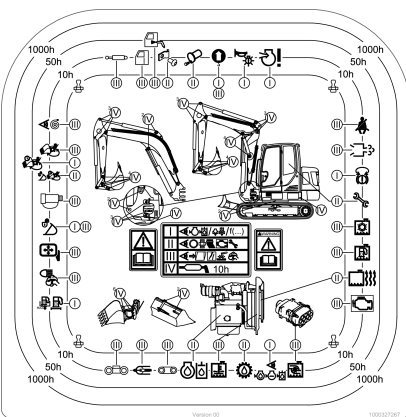


Fig. 41

**Meaning**

Maintenance intervals

**Position**

On the cabin, left side

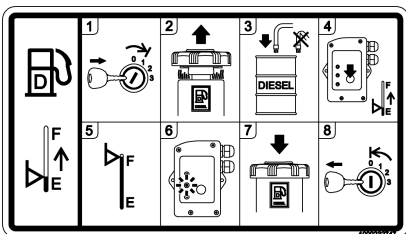


Fig. 42

**Meaning**

Fuel-filling pump

**Position**

Under the valve cover



Fig. 43

**Meaning (option)**

Reflectors

**Position**

At the rear left and right of the vehicle

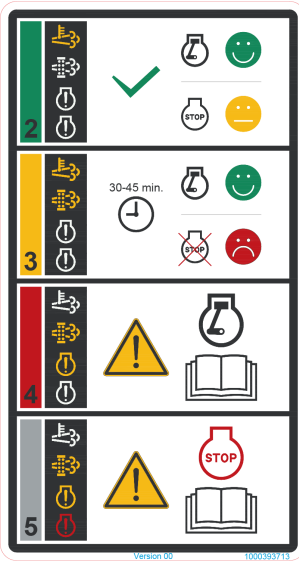


Fig. 44

**Meaning**

DPF loading condition

**Position**

On the right inside the cab

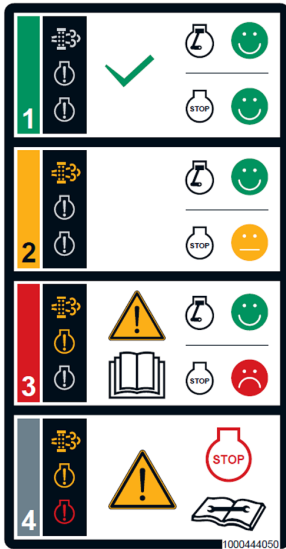


Fig. 45

**i Information**

Type, quantity, and position of the labels depend on options, country and vehicle.



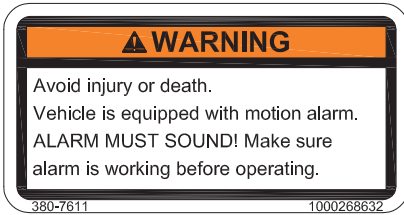


Fig. 47

**Position**  
On the headliner



Fig. 48

**Position**  
On the headliner

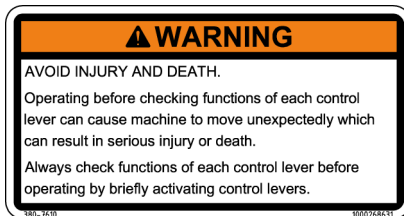


Fig. 49

**Position**  
On the headliner

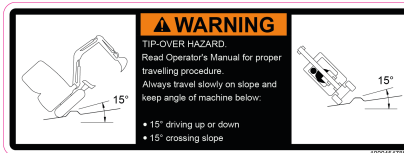


Fig. 50

**Position**  
On the headliner

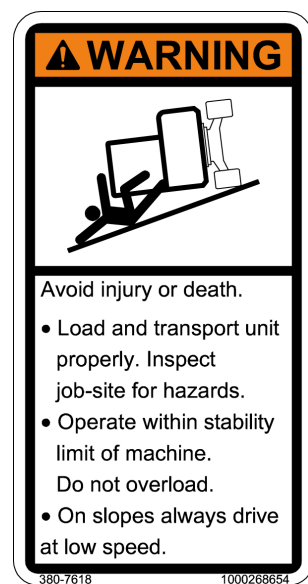


Fig. 51

**Position**  
On the B pillar on the left

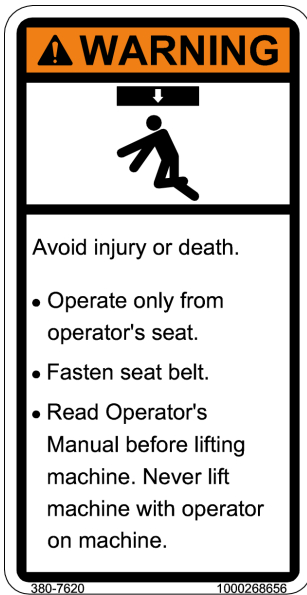


Fig. 52

**Position**

On the B pillar on the left

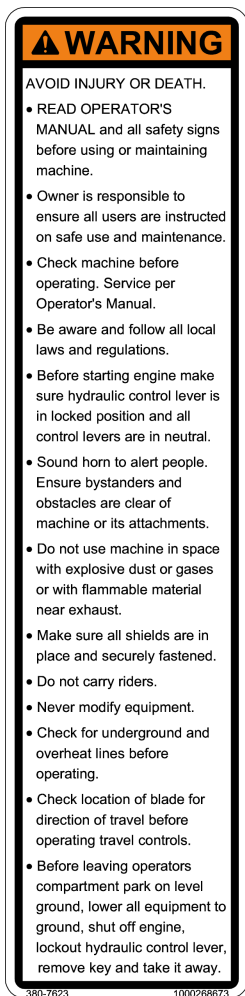


Fig. 53

**Position**

On the B pillar on the left

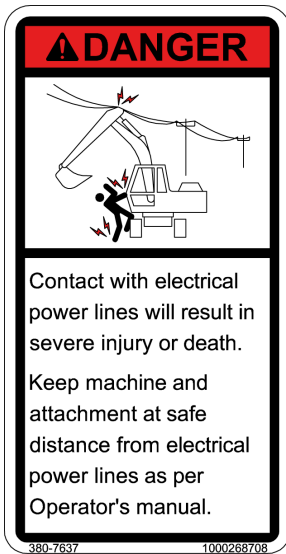


Fig. 54

**Position**

On the B pillar on the left



Fig. 55

**Position**

In the engine compartment on the bulkhead

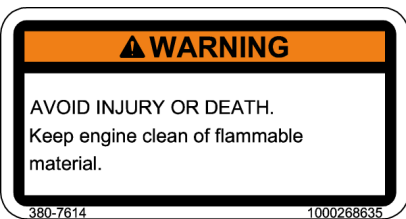


Fig. 56

**Position**

In the engine compartment on the bulkhead

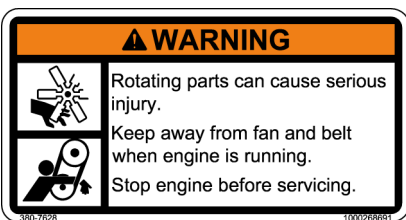


Fig. 57

**Position**

In the engine compartment on the bulkhead

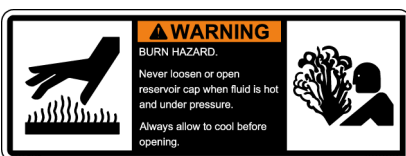


Fig. 58

**Position**

In the engine compartment on the bulkhead

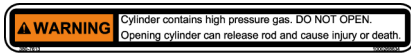


Fig. 59

**Position**

On the gas struts of the engine cover, the rocker cover and the front window

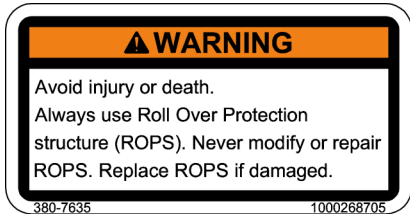


Fig. 60

**Position**

On the right side of the roof

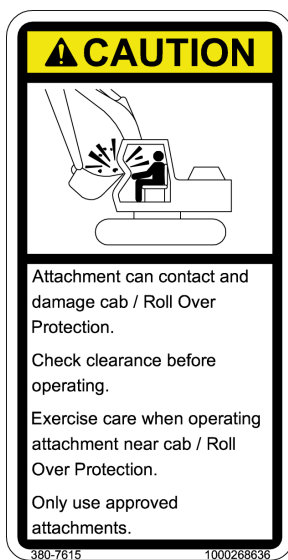


Fig. 61

**Position**

On the left side of the roof



Fig. 62

**Position**

On the boom on the left and right

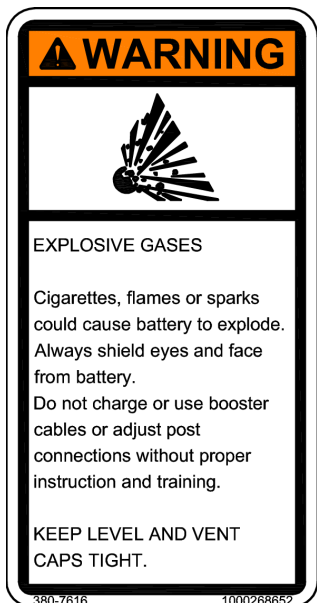


Fig. 63

**Position**

On the battery cover

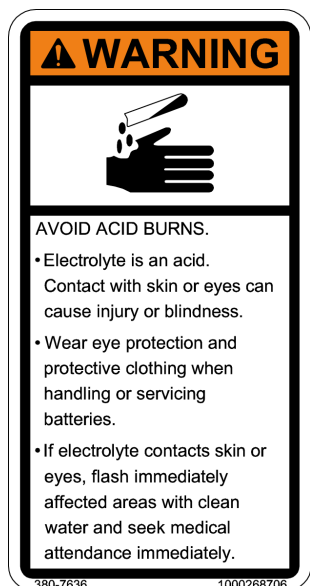


Fig. 64

**Position**

On the battery cover

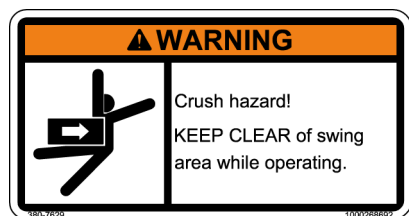


Fig. 65

**Position**

At the bottom left of the rear window

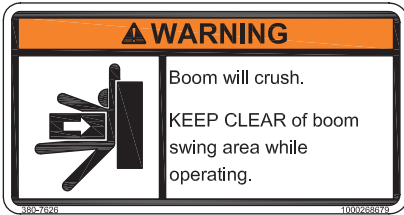


Fig. 66

**Position**

At the front left and right of the chassis



Fig. 67

**Position**

On the front window

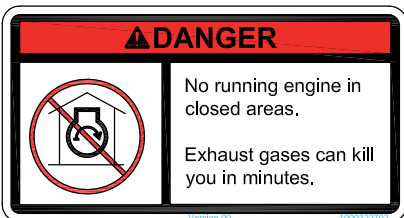


Fig. 68

**Position**

On the headliner



Fig. 69

**Position**

On the engine cover



Fig. 70

**Meaning**

Do not use starting-aid sprays.

**Position**

In the engine compartment on the bulkhead



Notes:

## 4 Putting into operation

### 4.1 Cabin/control stand

---

 **CAUTION****Risk of injury when getting on and off!**

Entering or exiting incorrectly can cause injury.

- ▶ Keep the mandatory stages **A** and handles **B** clean and only use them for entering and exiting.
  - ▶ Face the vehicle as you enter and leave it.
  - ▶ Have damaged stages and handles replaced. Do not operate the vehicle.
- 

---

 **CAUTION****Crushing hazard due to incorrectly locked door!**

Unlocked cabin doors can cause crushing.

- ▶ Lock the cabin door.
  - ▶ Use the handholds for closing.
- 

---

 **CAUTION****Injury hazard when opening or closing the front window!**

Opening or closing the front window can cause injury.

- ▶ Use both handles.
  - ▶ Duck your head.
  - ▶ Let both locks lock into place.
  - ▶ Keep the window channel clear.
-

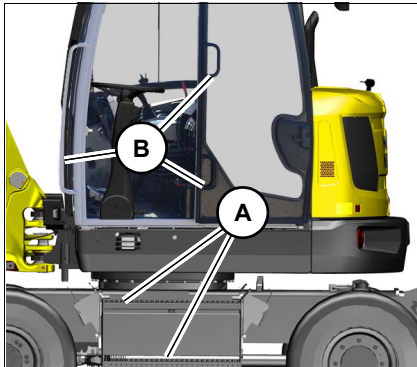


Fig. 71

### Getting on and off

Use footholds **A** and handles **B**. Do support yourself on the control elements.

Two hands and one foot must be always in contact with the vehicle when getting on and off.



### Information

When entering or leaving the cabin, the door must be locked in the arrester.

### Unlocking and locking the door

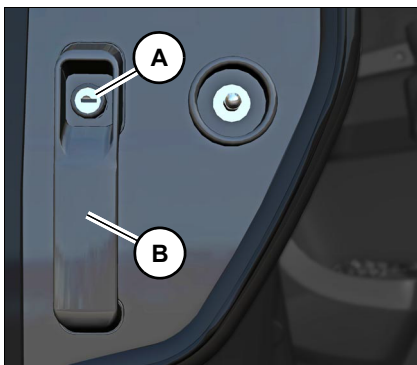


Fig. 72

#### Unlocking:

Turn the key in door lock **A** anticlockwise.

#### Locking:

Turn the key in door lock **A** clockwise.

## Opening and closing the door

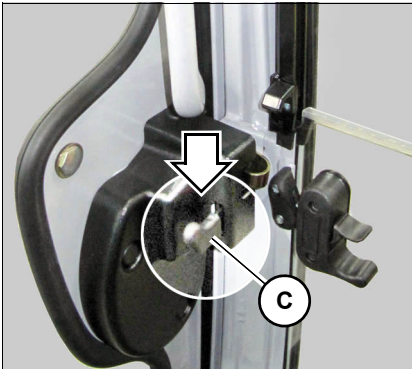


Fig. 73 (symbolic representation)

### Opening:

Press door lock **A** and pull door handle **B**.

### Closing:

Close the door applying firm pressure.

### Opening the door from the inside:

Press lever **C** on the door lock downward.

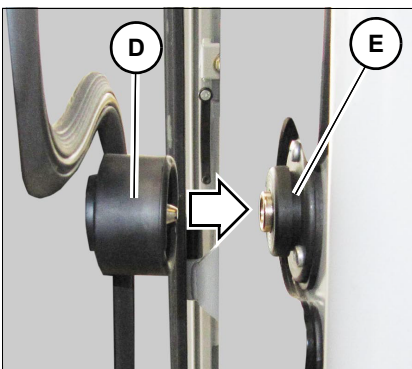


Fig. 74 (symbolic representation)

### Securing an open door

Press bracket **D** firmly against arrester **E**.

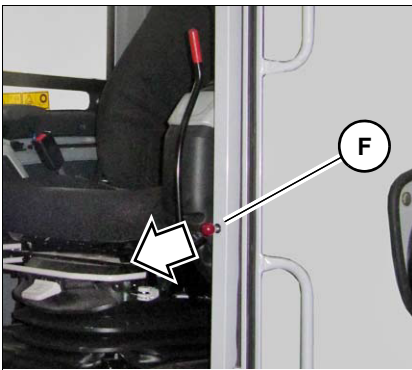


Fig. 75

### Releasing the door arrester

Pull button **F**.

### Opening/closing the front window

#### **NOTICE**

Before opening/closing either of the front windows, put the steering column in the rear position to avoid damaging the window – see chapter “[Adjusting the steering column](#)” on page 4-22.



Fig. 76

#### **Opening the upper front window**

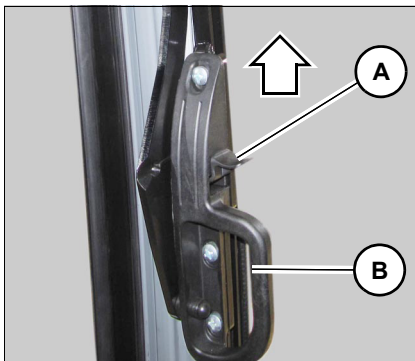


Fig. 77

1. Press and hold levers **A** on the left and right, and pull the front window forward with handles **B** on the left and right.
2. Release levers **A** and press the window upward until it engages.

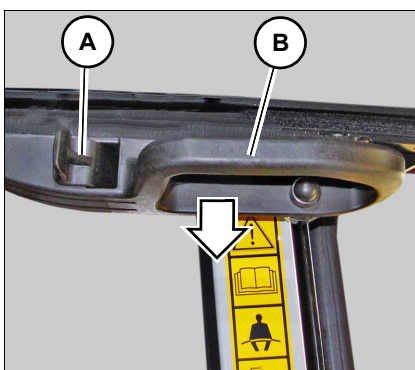


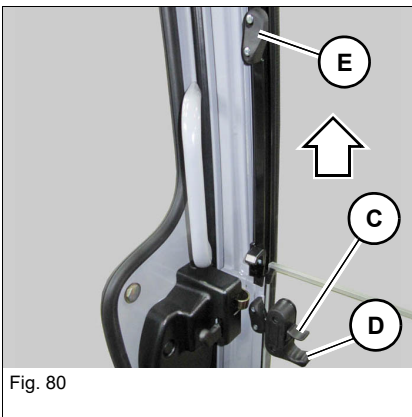
Fig. 78

#### **Closing the upper front window**

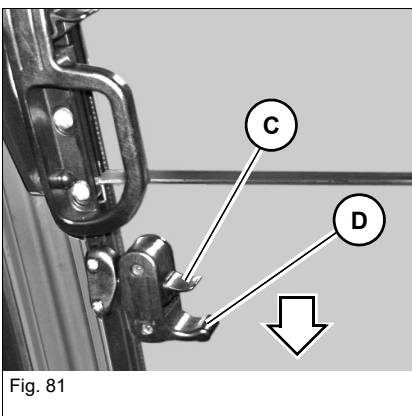
1. Press levers **A** on the left and right, and pull the front window downward with handles **B** on the left and right.
2. Press the front window fully forward and release levers **A**.



### Opening the lower front window



Press levers **C** on the left and right, and pull the front window upward with handles **D** on the left and right until the front window engages with guide **E**.



### Closing the lower front window

Keep levers **C** pressed on the left and right, and pull the lower front window downward with handles **D** until the front window engages.



Fig. 82

### Opening the whole front window

1. Open the lower front window as described on page 4-5.
2. Open both windows together as described on page 4-4.

### Closing the whole front window

1. Close both windows together as described on page 4-4.
2. Close the lower front window as described on page 4-5.

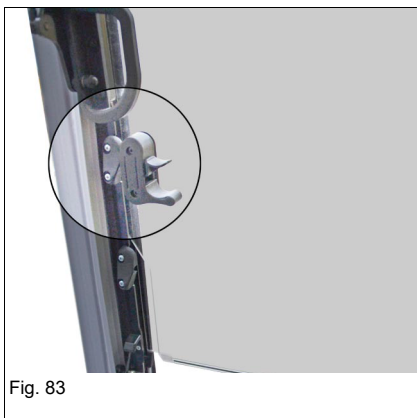


Fig. 83

---

### NOTICE

If the protective Front Guard structure is installed, the front windows can be damaged.

- ▶ The lower front window must be fully open when the entire front window is opened or closed (*Fig. 83*).
- 



Fig. 84

### Opening the front window to a gap (ventilation position)

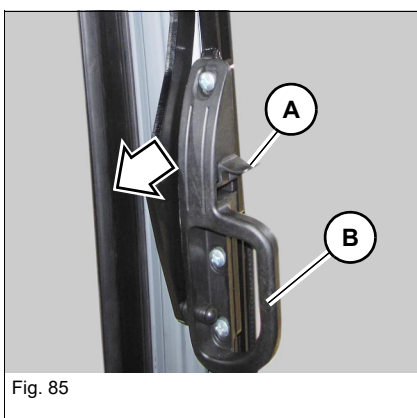


Fig. 85

1. Press levers **A** on the left and right, and slightly pull handles **B** on the left and right.
  - The front window is unlocked.
2. Release levers **A** and pull handles **B** on the left and right until the front window engages.



Fig. 86

**Integrated rain shield**

When the entire front window is open, the lower front window can be used as an additional means of protection against rain.

**Information**

The rain canopy cannot be used when the Front Guard is mounted.

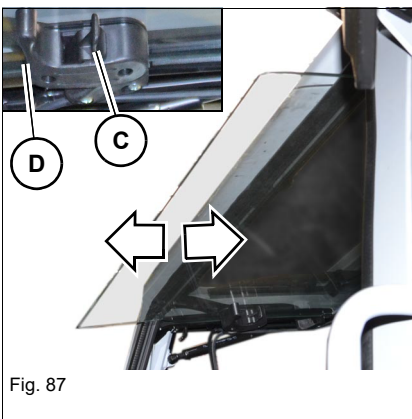


Fig. 87

**Open**

1. Press and hold levers **C** on the left and right, and push the front window all the way forward.
2. Pull the front window backward with handles **D** on the left and right until it engages.

**Close**

1. Press levers **C** on the left and right and pull the front window backward.
2. Release levers **C** and pull the window all the way backward until it engages.

**Opening/closing the side windows**

Both side windows on the right can be opened.

**Open**

Press lever **A** and let the side window engage in the required recess.

**Close**

Press lever **A** and close the side window.

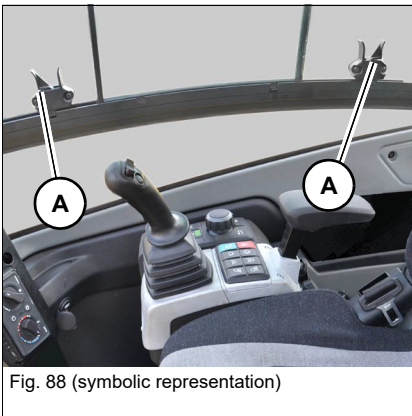


Fig. 88 (symbolic representation)

### Sun blind

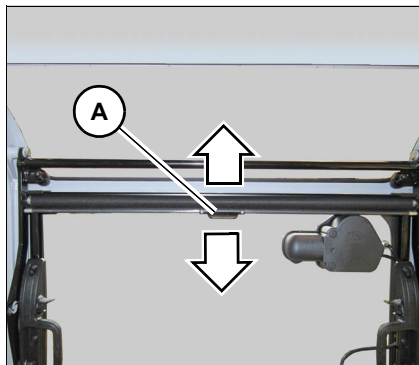


Fig. 89

The sun blind protects the operator against direct sunlight through the front or roof windows.

The sun blind can be fastened at the headliner or front window with flap **A**.

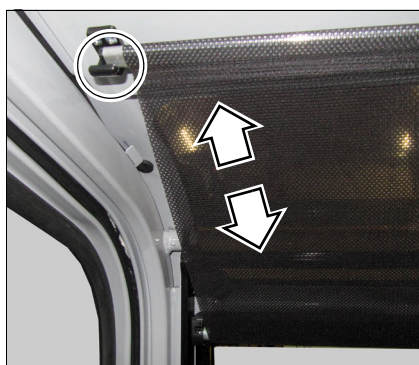


Fig. 90

#### Fastening the sun blind at the roof window

Pull the sun blind upward with flap **A** and hitch it on the headliner on the left and right.

#### Removing the sun blind at the roof window

Unhitch and roll up the sun blind.

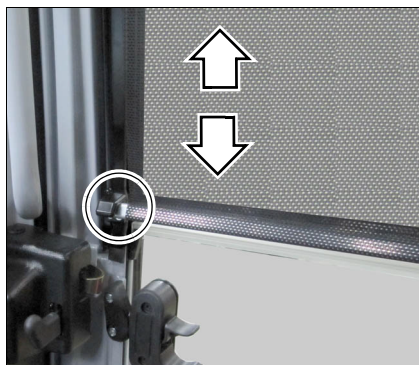


Fig. 91

#### Fastening the sun blind at the front window

Pull the sun blind downward with flap **A** and hitch it on the front window on the left and right.

---

#### Information

If the front window is raised, the sun blind then protects against the sun shining through the roof window.

---

#### Removing the sun blind at the front window

Unhitch and roll up the sun blind.

## Emergency exit

There are several possibilities for an emergency exit:

- Front Guard not installed: front or right window
- Front Guard installed: rear window

---

### **WARNING**

#### **Injury hazard when leaving the cabin in an emergency!**

An emergency exit can cause serious injury or death.

- ▶ The front and the right of the vehicle have neither footholds nor handles for safely exiting the cabin.

---

## Emergency exit on vehicles equipped with protective Front Guard structures (option)

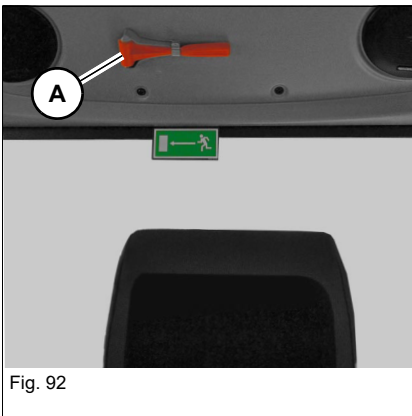
---

### **WARNING**

#### **Injury hazard when leaving the cabin in an emergency!**

An emergency exit can cause serious injury or death.

- ▶ There are no footholds nor handles for safely exiting the cabin at the rear and the right side of the vehicle.
- ▶ Protect your face and eyes from the glass splinters flying around when you smash a window.
- ▶ Pay attention to glass splinters during an emergency exit.



The rear or right windows can be used as an emergency exit if the cabin door or front windows are blocked.

Smash the rear window with emergency hammer **A** above the rear window.

### Comfort seat

---

#### **WARNING**

##### **Accident hazard due to seat adjustment during vehicle operation!**

Adjusting the operator seat during vehicle operation can cause serious injury or death.

- ▶ Adjust the operator seat before putting the vehicle into operation.
  - ▶ Ensure that the levers are locked into place.
- 

#### **Weight adjustment**

---

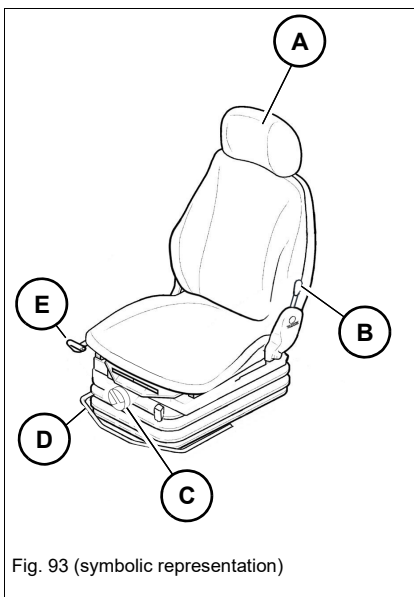
#### **CAUTION**

##### **Spinal cord injury due to incorrect seat adjustment!**

An incorrect weight adjustment can cause injury to the spinal cord.

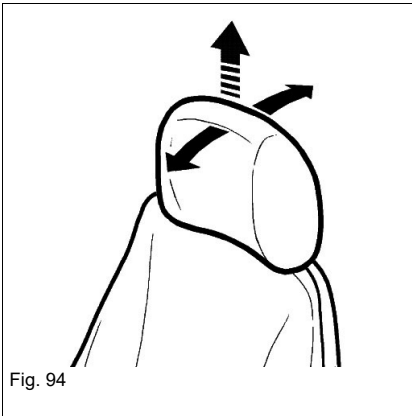
- ▶ Ensure that the seat is correctly adjusted to the operator's weight before vehicle travel or operation.
- 

The comfort seat can be adjusted as follows:

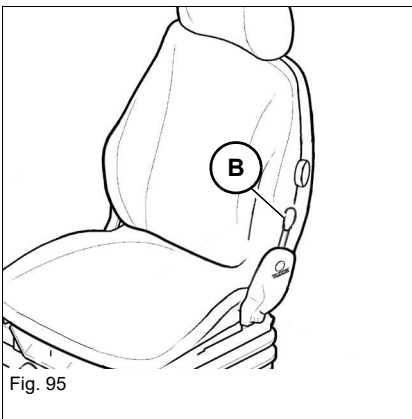


- A** Headrest
- B** Backrest
- C** Weight
- D** Horizontal adjustment of seat and control lever console
- E** Horizontal seat adjustment

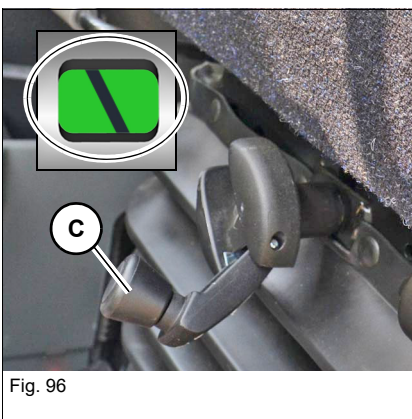
Fig. 93 (symbolic representation)

**Headrest**

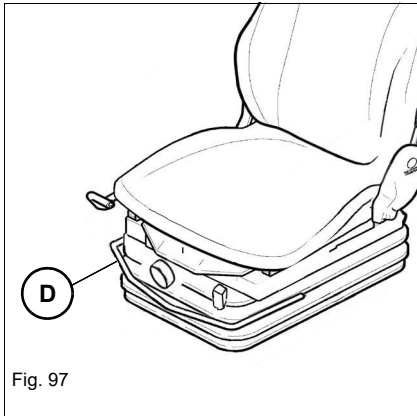
Function	Operation
Height adjustment	Pull up or push down
Inclination adjustment	Push forward or backward

**Backrest**

1. Sit down on the operator seat.
2. Push lever **B** backward and adjust the backrest.

**Adjusting the weight**

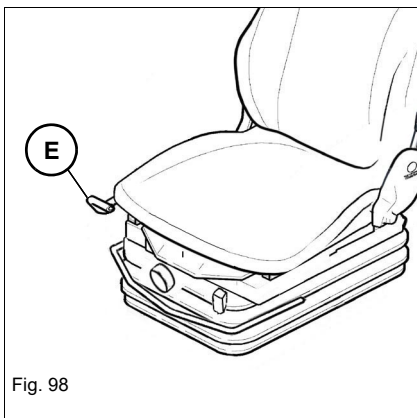
1. Sit down on the operator seat and unfold crank **C**.
2. Rotate crank **C** until the highlighted symbol appears.



### Horizontal adjustment of seat and control lever console

The seat and control lever console can be adjusted simultaneously. This ensures a constant distance between the operator seat and the control levers.

1. Sit down on the operator seat.
2. Pull lever **D** upward and lock seat console into place.



### Horizontal seat adjustment

1. Sit down on the operator seat.
2. Pull lever **E** upward and lock seat console into place.

**Air-suspension comfort seat (option)**

**WARNING**
**Accident hazard due to seat adjustment during vehicle operation!**

Adjusting the operator seat during vehicle operation can cause serious injury or death.

- ▶ Adjust the operator seat before putting the vehicle into operation.
- ▶ Ensure that the levers are locked into place.

**Weight adjustment**

**CAUTION**
**Spinal cord injury due to incorrect seat adjustment!**

An incorrect weight adjustment can cause injury to the spinal cord.

- ▶ Ensure that the seat is correctly adjusted to the operator's weight before vehicle travel or operation.


**Information**

The weight can only be adjusted when the starter is engaged.

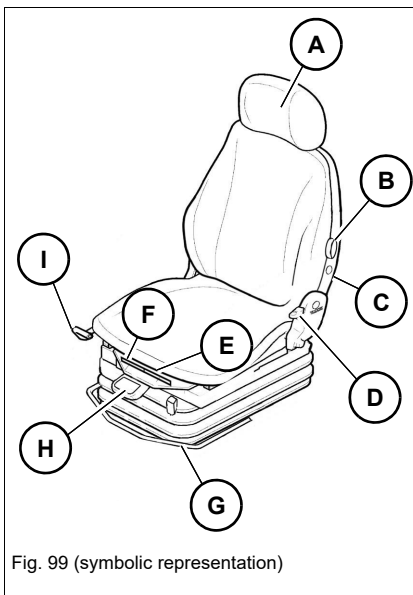
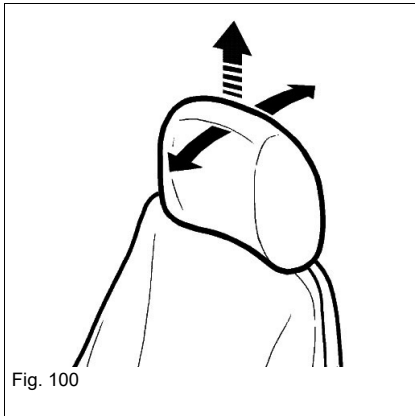


Fig. 99 (symbolic representation)

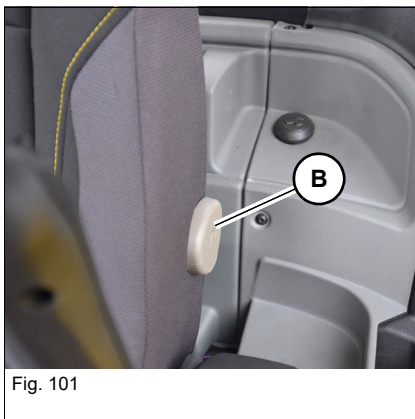
The air-suspension seat can be adjusted as follows:

- A** Headrest
- B** Lumbar support
- C** Heated seat
- D** Backrest
- E** Length of seat surface
- F** Inclination of seat surface
- G** Horizontal adjustment of seat and control lever console
- H** Operator weight
- I** Horizontal seat adjustment



### Headrest

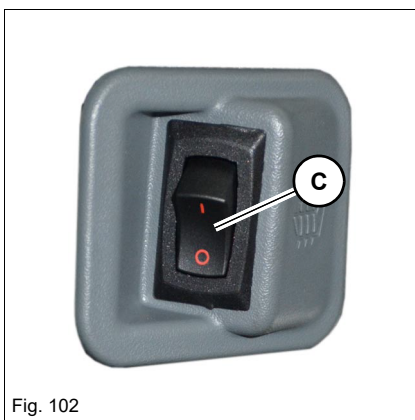
Function	Operation
Height adjustment	Pull up or push down
Inclination adjustment	Push forward or backward



### Lumbar support

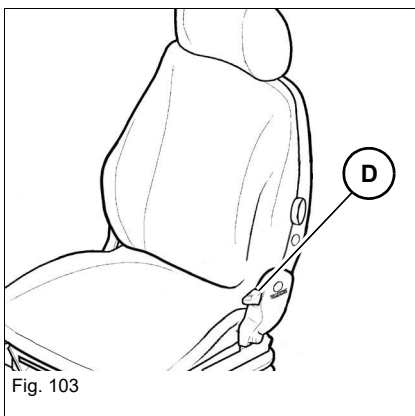
The lumbar support can be adjusted to the natural curvature of the spine. This reduces the load on the spine and ensures a non-fatiguing seating position.

Adjust the lumbar support: Turn knob **B**



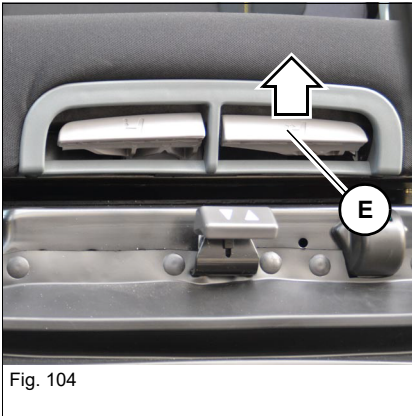
### Heated seat

Press button **C** to switch on or off.

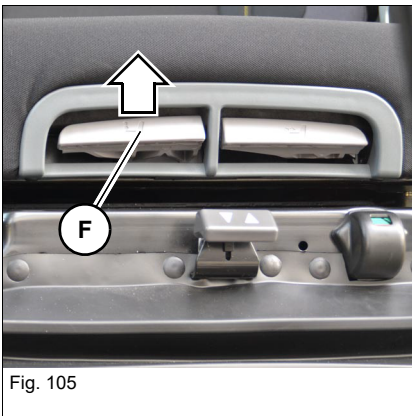


### Backrest

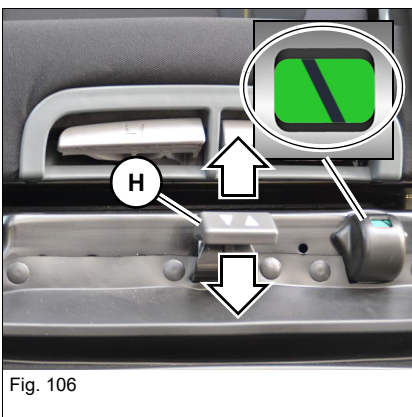
1. Sit down on the operator seat.
2. Pull lever **D** and adjust the backrest.

**Length of seat surface**

1. Sit down on the operator seat.
2. Pull lever **E** upward and adjust the length of the seat surface.
  - The seat surface must engage.

**Inclination of seat surface**

1. Sit down on the operator seat.
2. Pull lever **F** upward and adjust the inclination of the seat surface.
  - The seat surface must engage.

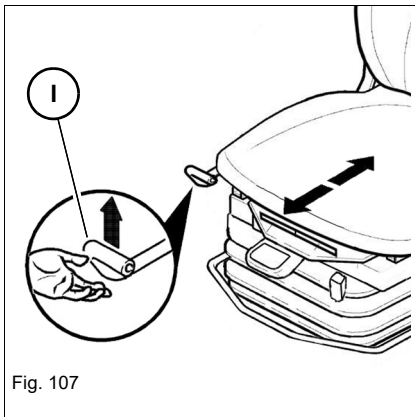
**Weight adjustment**

1. Sit down on the operator seat.
2. Push or pull push button **H** until the highlighted symbol appears.

**NOTICE**

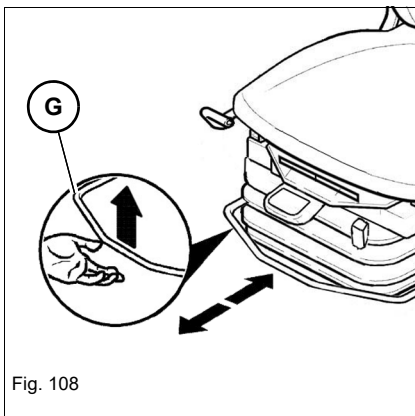
Possible damage to the compressor due to long operation of the switch.

- ▶ Do not hold the push button more than one minute.



### Horizontal seat adjustment

1. Sit down on the operator seat.
2. Pull lever **I** upward and lock seat console in the required position.



### Horizontal adjustment of seat and control lever console

The seat and control lever console can be adjusted simultaneously. This ensures a constant distance between the operator seat and the control levers.

1. Sit down on the operator seat.
2. Pull lever **G** upward and lock seat console in the required position.



## Seat belt

---

 **WARNING**

**Injury hazard if the seat belt is not fastened correctly or not at all!**

Fastening the seat belt incorrectly, or not at all, can cause serious injury or death.

- ▶ Firmly fasten your seat belt over your hips before starting the engine.
  - ▶ Do not loosen the seat belt while the engine is running. This also applies to the work interruptions.
  - ▶ Do not fasten a twisted seat belt, and do not place it over hard, edged or fragile items in your clothes.
  - ▶ Ensure that the buckle is inserted.
  - ▶ Do not use seat belt extensions.
- 

 **CAUTION**

**Injury hazard due to damaged or dirty seat belt!**

A damaged or dirty seat belt can cause serious injury or death.

- ▶ Keep the seat belt and buckle clean, and check them for damage.
  - ▶ Have a damaged seat belt and buckle immediately replaced by an authorized service center.
  - ▶ Have the seat belt immediately replaced after every accident and the load-bearing capacity of the fastening points and seat fixtures checked by an authorized service center.
-

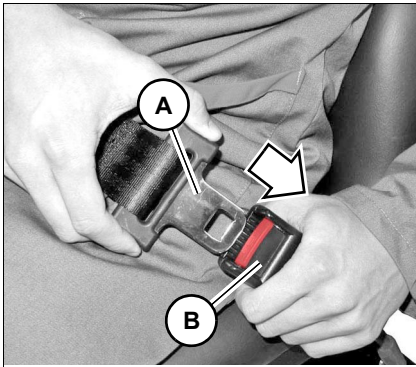


Fig. 109

### Fastening the seat belt

Insert buckle latch **A** into seat belt buckle **B** until it engages.

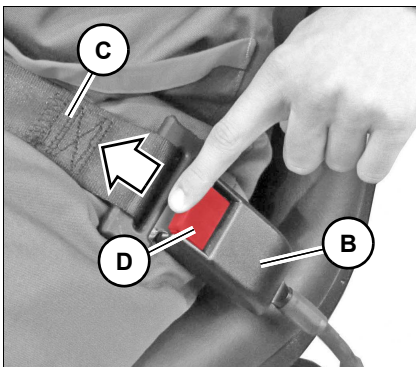


Fig. 110

### Unfastening the seat belt

Press the red button **D** on the buckle **B** until the buckle latch comes out.

➔ Seat belt **C** is automatically retracted.

## Visual aids

---

### **WARNING**

#### **Risk of injury to persons in the danger zone!**

Persons in the danger area are possibly not seen when reversing the vehicle and this can cause accidents with serious injuries or death.

- ▶ Adjust the existing visual aids (for example the rearview mirrors) correctly.
  - ▶ Interrupt work immediately if persons enter the danger zone.
  - ▶ Pay attention to the movements and changing positions of attachments and persons.
-

---

 **WARNING****Accident hazard due to restricted field of vision on the job site!**

Accidents resulting in serious injury or death can be caused by a restricted field of vision.

- ▶ Do not allow anyone to stay in the danger zone.
  - ▶ Use suitable visual aids if necessary (for example a camera, mirrors, guide).
  - ▶ Additional equipment or attachments must not be installed if they impair visibility.
- 

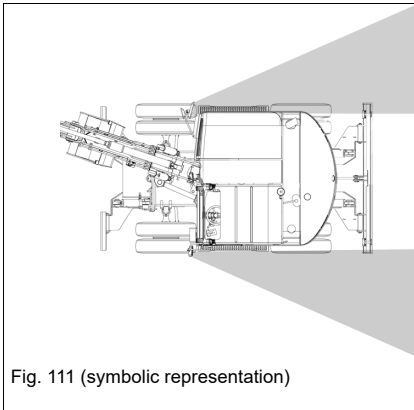
---

 **WARNING****Accident hazard due to incorrect adjustment of visual aids!**

Incorrectly adjusted visual aids can cause serious injury or death.

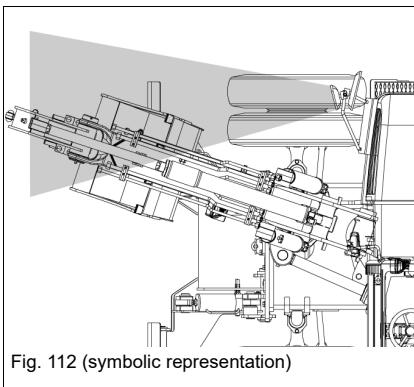
- ▶ Before starting work, ensure that all visual aids are clean, functional and adjusted in accordance with the instructions in this Operator's Manual.
  - ▶ If no image appears on the camera monitor, stop vehicle operation. Only put the vehicle back into operation once the damage has been repaired.
  - ▶ Immediately replace damaged or broken visual aids.
  - ▶ Convex mirrors enlarge, reduce or distort the field of view.
  - ▶ The operator must follow the national and regional regulations.
- 

- Use safety-oriented ladders or work platforms for adjustment work on the machine.
- Do not use vehicle parts or attachments as a climbing aid.
- Set the boom to travel position before adjusting the mirrors.



### Outside rearview mirrors on left and right

- Ensure sufficient visibility from the operator seat onto the job site.
- Ensure maximum visibility to the rear.
- Ensure visibility of the rear left edge of the vehicle in the mirror on the left.
- Ensure visibility of the rear right edge of the vehicle in the mirror on the right.



### Upper carriage mirror on the front

- Ensure sufficient visibility from the operator seat onto the job site.
- The area covered by the boom and the area in front of the track on the right must be visible in the mirror.
- The front edge of the track on the right must be barely visible in the mirror.



### Information

Wacker Neuson recommends adjusting the mirrors with two persons.



### Information

Do not make any changes or modifications that impair visibility. Otherwise the vehicle does not meet the requirements for conformity and registration.

## Reversing camera (option)

The reversing camera is located on top of the engine cover. It allows the operator to see the area behind the vehicle.

toggling between camera view (1) and status display (2):

1. Press control button **A**.
2. Turn control button **A** to select menu item **camera view** or **status display**.
3. Press control button **A**.

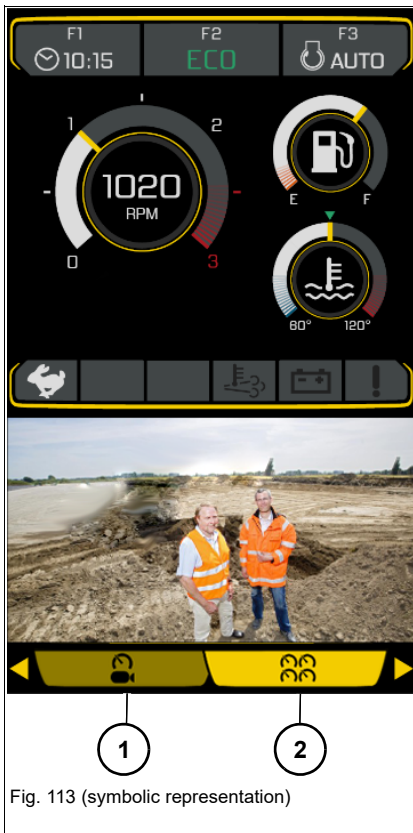


Fig. 113 (symbolic representation)



Fig. 114

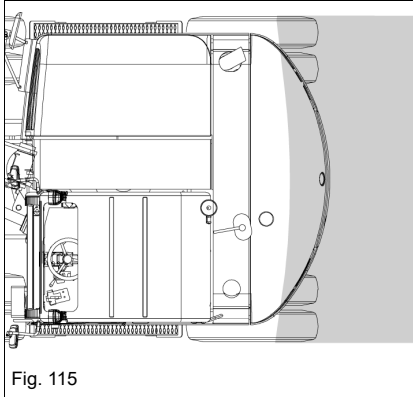


Fig. 115

### Adjusting the camera – rear visual range

- Ensure sufficient visibility from the operator seat onto the job site.
- The immediate area at the rear of the vehicle and the outside left and right sides of the stabilizer blade must be visible.

### Adjusting the steering column

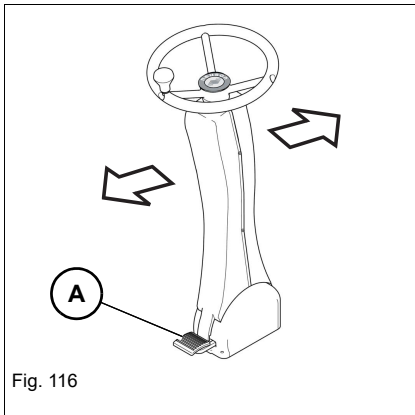
---

**!** **WARNING****Accident hazard during steering column adjustment!**

Adjusting the steering column during machine operation can cause serious injury or death.

► Adjust the steering column only at machine standstill.

---



1. Press and hold pedal **A** and move the steering column continuously to the front or rear.
2. Release pedal **A**.

## Armrest

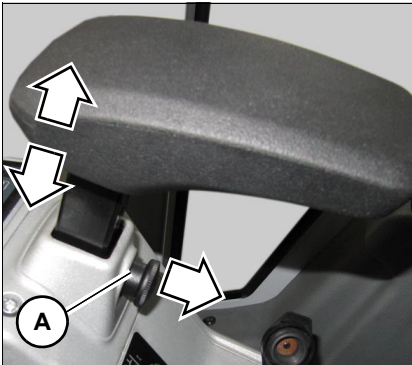


Fig. 117

1. Hold the armrest and pull out button **A**.
2. Adjust the armrest height.
3. Release button **A**.

## Fire extinguisher



Fig. 118

A fire extinguisher is not available from Wacker Neuson. Contact a Wacker Neuson service center for the installation of a fire extinguisher (DIN-EN 3).

---

### **Information**

Ensure the firm and safe installation of the fire extinguisher. Inspect the holder and the fire extinguisher regularly. Observe the manufacturer's indications.

---

### Protective structures

Protective structures are additional elements that protect the operator against hazards. These elements can be installed later on or as standard equipment.

#### **DANGER**

##### **Accident hazard due to modified cabin or protective structures!**

Modifications (for example drilling) weaken the structure and causes serious injury or death.

- ▶ No drilling, cutting or grinding.
- ▶ Do not install any brackets.
- ▶ No welding, straightening or bending.
- ▶ Replace the complete protective structure if it is damaged, deformed or cracked.
- ▶ Contact a Wacker Neuson service center in case of doubt.
- ▶ Retrofit and repair work may only be performed by a Wacker Neuson service center.
- ▶ Replace self-locking fasteners.

#### **Information**

Machine operation is only allowed with a correctly installed and intact cabin.

For additional protection, only use correctly installed and intact Wacker Neuson protective structures that have been released for the vehicle.

#### **Responsibility for vehicle equipped with protective structures**

The decision regarding the necessary protective structures (type and level I or II) must be made by the machine owner and depends on the specific work situation.

The vehicle owner must observe the national regulations and he must inform the operator on the protective structure to be used in a specific work situation.

### Assembly

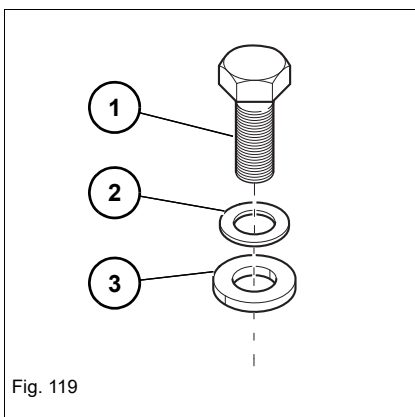


Fig. 119

The term **screw** is used for fastening equipment used in the following sequence:

1. Screw
2. Schnorr washer
3. Washer

#### **Information**

Only install protective structures with the help of a crane.

**Protective FOPS structure category II (option)**

**DANGER**
**Crushing hazard due to falling objects!**

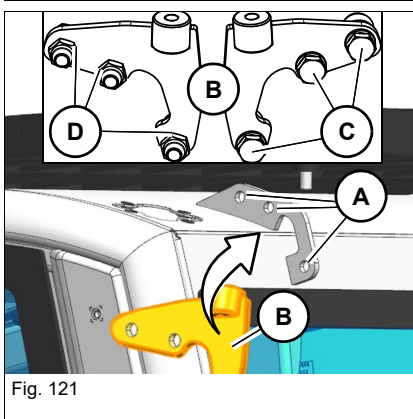
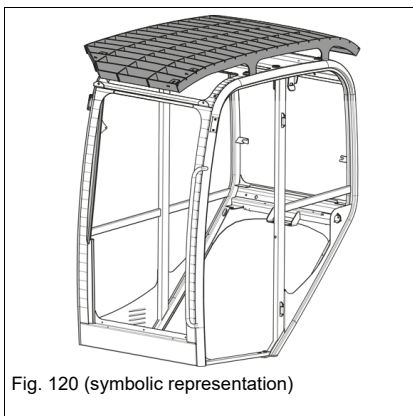
Causes serious injury or death.

- ▶ Install a protective FOPS structure for vehicle operation in areas with danger of falling objects.


**Information**

The protective FOPS structure corresponds to category II according to ISO 10262:1998/EN ISO 3449:2008.

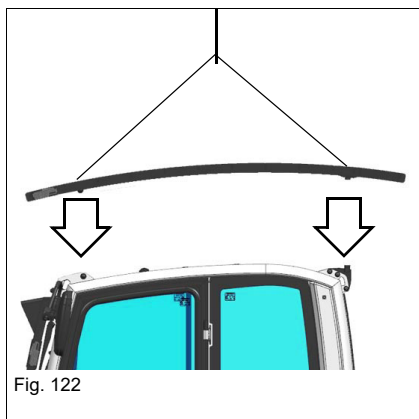
- ▶ The vehicle owner must ensure that the hazard situation is evaluated and that the national regulations are observed.
- ▶ The vehicle owner must ensure that only work is performed that does not require any higher protection.
- ▶ Accidents cannot be fully avoided despite equipping a vehicle with protective structures.



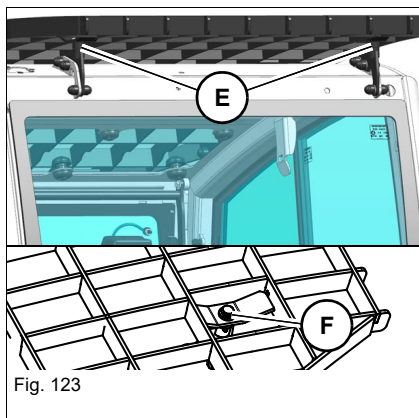
1. Stop and park the vehicle. Stop the engine. See "Preparing lubrication"

**A:** mounting points rear left and right (for vehicles without air conditioning system).

2. Install brackets **B** with screws **C** and lock nuts **D** and tighten to 65 Nm (48 ft.lbs).

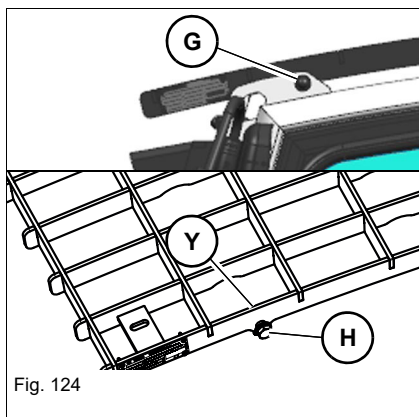


3. Place the FOPS screen on the cabin roof.



**E:** mounting points for brackets **B** left and right.

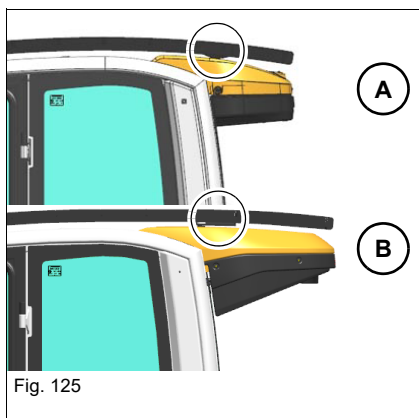
4. Install screws **F** and tighten them to 45 Nm (33 ft.lbs).



**G:** mounting points at the front left and right.

5. Install screws **H** and lock nuts **J** and tighten to 110 Nm (81 ft.lbs.).

6. Put caps on all screws and nuts.



### **i** Information

If the vehicle is equipped with air-conditioning, point 2 does not apply. The housing of the air-conditioning system is equipped with mounting bushings for the rear screws.

**A:** housing version 1

**B:** housing version 2

## Protective Front Guard structure category II (option)

### **DANGER**

**Danger of piercing/penetration by objects from the front!**

Causes serious injury or death.

- ▶ Install a protective Front Guard structure in areas with danger from the front (for example pipes, tree trunks).

### **Information**

The protective Front Guard structure corresponds to category II according to ISO 10262:1998.

- ▶ The vehicle owner must ensure that the hazard situation is evaluated and that the national regulations are observed.
- ▶ The vehicle owner must ensure that only work is performed that does not require any higher protection.
- ▶ Accidents cannot be fully avoided despite equipping a vehicle with protective structures.

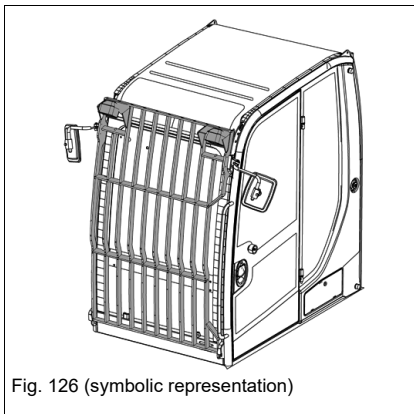


Fig. 126 (symbolic representation)

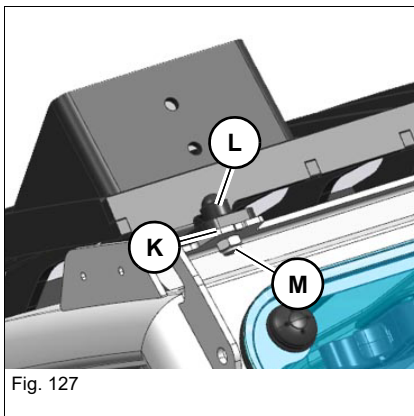
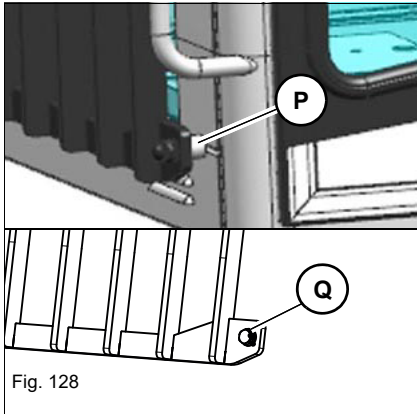


Fig. 127

1. Stop and park the vehicle. Stop the engine. See "Preparing lubrication"

**K:** mounting points top left and right.

2. Install screws **L** and lock nuts **M** and tighten to 110 Nm (81 ft.lbs.).



**P:** mounting points bottom left and right.

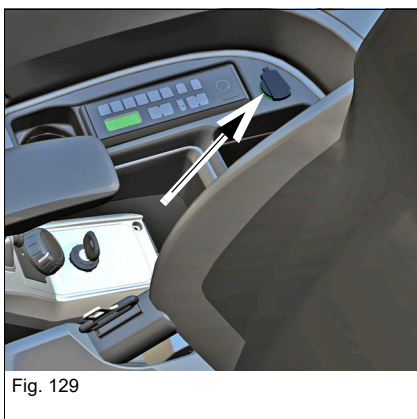
3. Install screws **Q** and tighten to 110 Nm (81 ft.lbs.).

4. Put caps on all screws and nuts.

### Document box (option)

A document box behind the seat is available as an option.

### 12 V connection



A 12 V connection is located at the rear right inside the cabin and on the right outside of the cabin.



#### Information

Maximum permissible current intensity for both connections: 15A

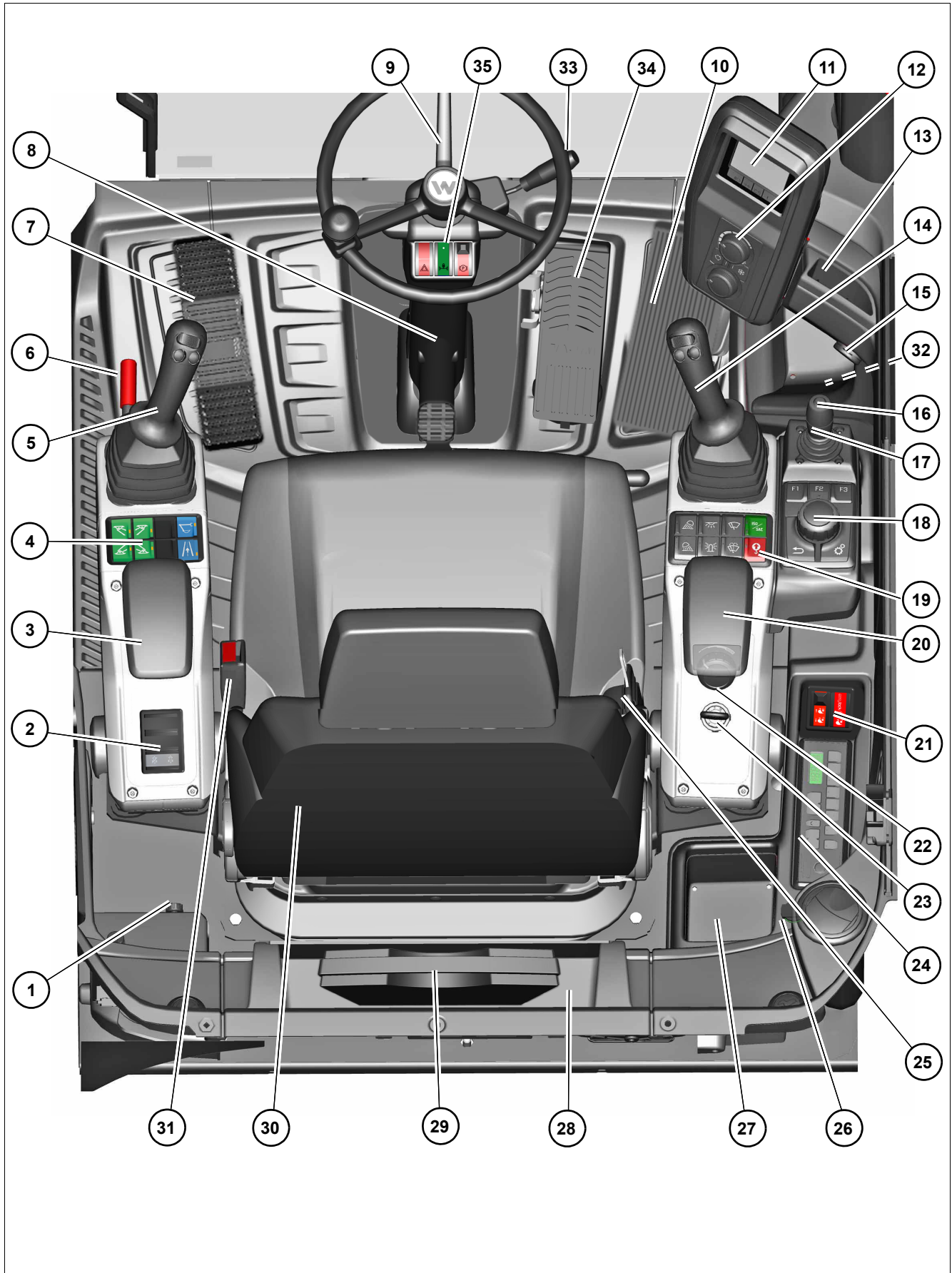




## **4.2 Overview of control elements**

This chapter describes the controls, and contains information on the function and handling of the indicator lights and controls in the cabin. The pages stated in the table refer to the description of the controls.

Cabin



Description	See page
1 Cabin fuse box	9-8
2 Switch panel on the left	4-32
3 Armrest (left)	4-23
4 Left switch panel <sup>1</sup>	4-32
5 Control lever on the left	5-37
6 Control lever base	4-51
7 Pedal for triple articulation boom (option)	5-51
8 Steering column pedal	4-22
9 Steering wheel	--
10 Accelerator pedal	5-1
11 Multi-functional display (3.5" standard; 7" with optional reversing camera)	4-44; 4-21
12 Temperature control/automatic air conditioning (option)	4-32
13 Compartment for mobile phone	--
14 Control lever on the right <sup>2</sup>	5-37
15 USB port (see Operator's Manual for radio)	--
16 Speed range selection	5-3
17 Stabilizer-blade lever	5-42
18 Jog Dial	4-32; 4-34
19 Switch panel on the right	4-32
20 Right armrest	--
21 Switch panel, right side (option)	5-60
22 Manual throttle	5-1
23 Ignition lock	4-50
24 Radio (option – see operator's manual for radio)	--
25 Seat belt	4-17
26 12 V power outlet	--
27 Storage compartment, right side	--
28 Rear storage compartment	--
29 Document box (option)	--
30 Operator seat	4-10; 4-13
31 Seat belt buckle	4-17
32 Drinks holder	--
33 Steering-column lever	5-31
34 Brake pedal	5-6
35 Steering wheel switch panel	5-31; 5-21; 5-7

1. Machine versions with only a stabilizer blade are equipped with a mechanical switch for operating and road-travel modes.
2. The two buttons on the right control lever have no function.

Operation overview

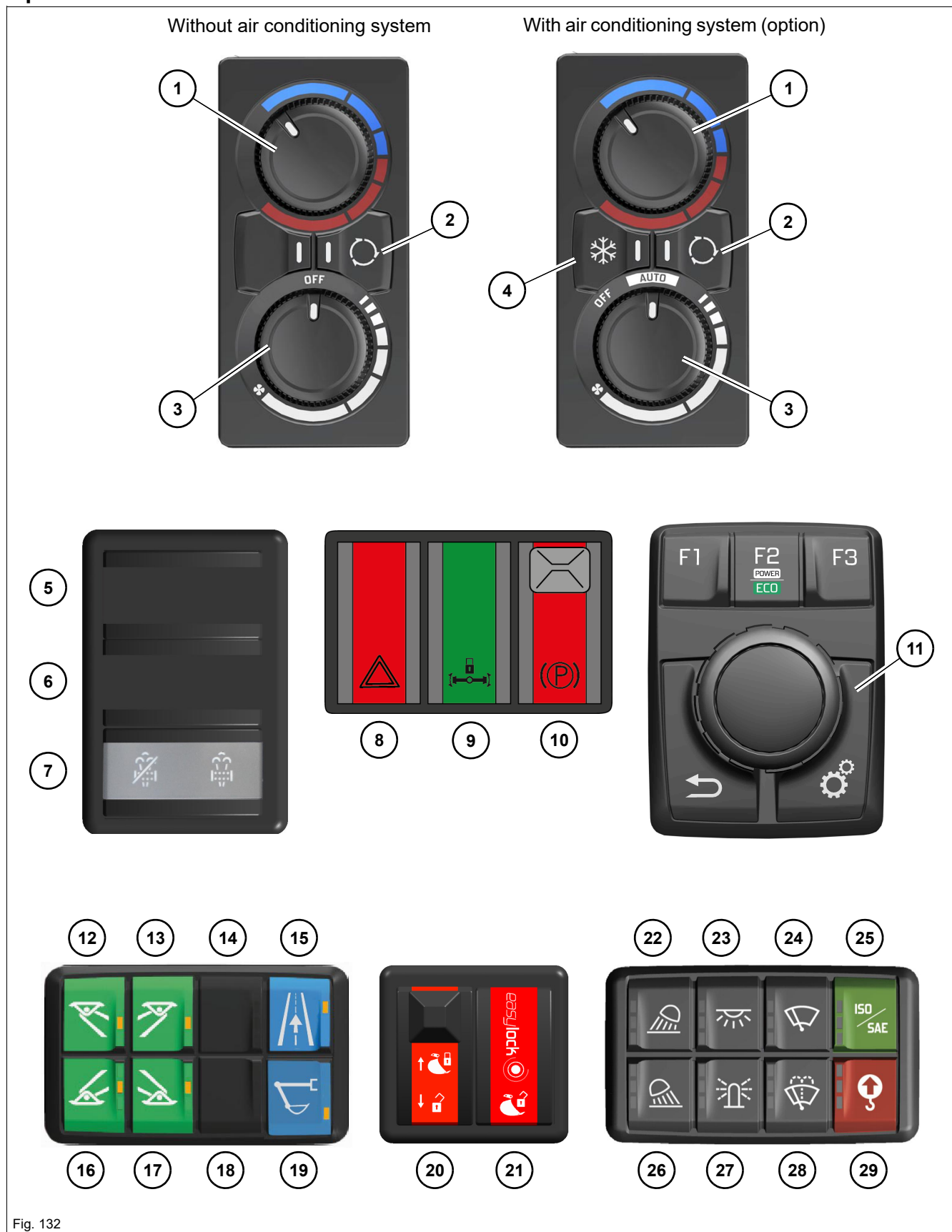


Fig. 132



<b>Description</b>	<b>See page</b>
1 Temperature setting	<a href="#">5-35</a>
2 Recirculated air mode	<a href="#">5-35</a>
3 Fan	<a href="#">5-35</a>
4 Air conditioning (option)	<a href="#">5-36</a>
5 Not assigned	--
6 Not assigned	--
7 Regeneration diesel particulate filter (404F-22T)	<a href="#">7-59</a>
8 Hazard warning system	<a href="#">5-31</a>
9 Oscillating-axle interlock	<a href="#">5-21</a>
10 Parking brake	<a href="#">5-7</a>
11 Jog Dial control unit	<a href="#">4-34</a>
12 Front left stabilizer leg/front stabilizer blade (option)	<a href="#">5-42</a>
13 Front right stabilizer leg/front stabilizer blade (option)	<a href="#">5-42</a>
14 Not assigned	--
15 Road-travel mode	<a href="#">5-9</a> ; <a href="#">5-13</a> ; <a href="#">5-20</a>
16 Rear left stabilizer leg/rear stabilizer blade (option)	<a href="#">5-42</a>
17 Rear right stabilizer leg/rear stabilizer blade (option)	<a href="#">5-42</a>
18 Not assigned	--
19 Operating mode	<a href="#">5-9</a> ; <a href="#">5-12</a>
20 Enable/disable hydraulic quickhitch	<a href="#">5-60</a>
21 Open hydraulic quickhitch	<a href="#">5-60</a>
22 Boom light	<a href="#">5-29</a>
23 Interior light	<a href="#">5-32</a>
24 Wiper	<a href="#">5-34</a>
25 ISO/SAE changeover (option)	<a href="#">5-38</a>
26 Roof and chassis lights (option)	<a href="#">5-30</a>
27 Rotating beacon (option)	<a href="#">5-32</a>
28 Wiper/wash system	<a href="#">5-34</a>
29 Safe load indicator	<a href="#">5-52</a>

**Jog dial**

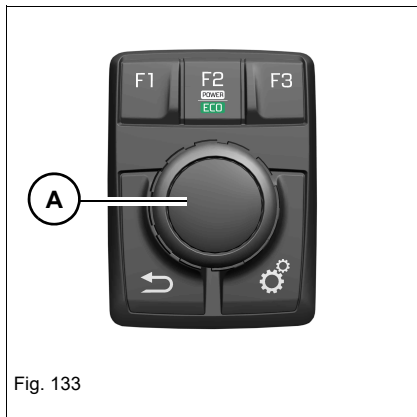


Fig. 133

**Control button**

Menu levels are selected (turn) and confirmed (press) with control button **A**.

Control element		Function	See page
F1		Displaying operating states	<a href="#">4-41</a>
F2		Changing the engine operating mode directly	<a href="#">5-2</a>
F3		Automatic engine speed setting	<a href="#">5-5</a>
Menu button	Press briefly		<ul style="list-style-type: none"> <li>• Selecting control circuits <a href="#">5-49</a></li> <li>• Changing the engine operating mode <a href="#">5-2</a></li> </ul>
	press and hold		<ul style="list-style-type: none"> <li>• Selecting and configuring attachments <a href="#">5-49</a></li> <li>• Stabilizer blade</li> <li>• Service menu/error messages <a href="#">8-7</a></li> <li>• Adjusting the multi-functional display <a href="#">4-44</a></li> <li>• Setting date and time</li> </ul>
Return button		Returning to previous menu	--
Control button		Selecting menu items (turn) Confirming menu items (press)	--



Fig. 134

**Daily and total operating hours**

Function	Push button
Change view	Press F1 briefly
Reset the daily operating hours	Press F1 longer

### 4.3 Control and warning lights overview

#### Display element/multi-functional display<sup>1</sup>

The display element and the multi-functional display inform the operator about operating states, required maintenance procedures and possible vehicle malfunctions.

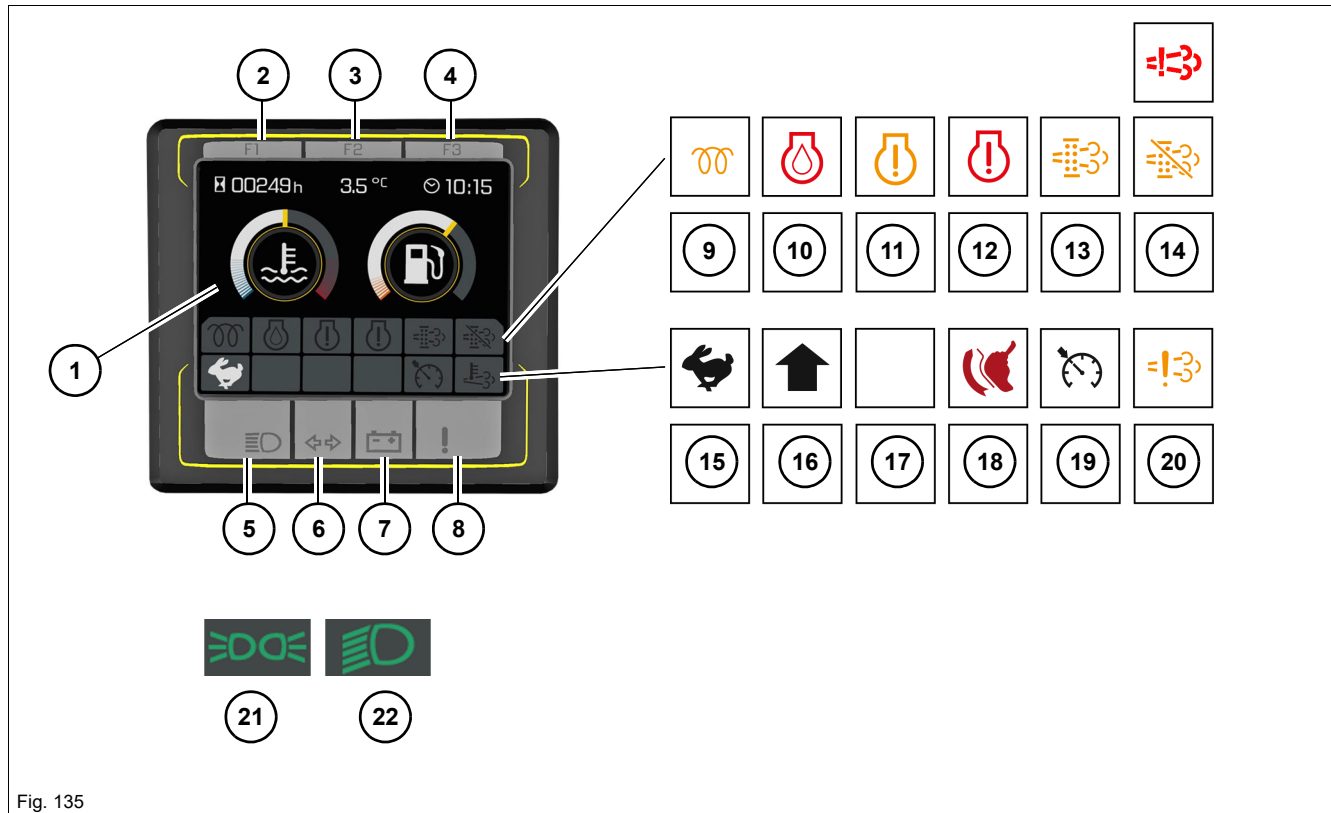


Fig. 135

#### **i** Information

The indicator lights are tested when the starter is engaged and are illuminated for a few seconds.

#### **i** Information

The indicator lights shown are only selected examples. All possible display variants are shown on the following pages.














#### **i** Information

The standard equipment of the vehicle includes a 3.5" multi-functional display.

If the **reversing camera** option is selected, a 7" multi-functional display is installed. Any differences between the two displays are indicated separately.

1. The assignment of the indicator lights can vary depending on the equipment.












nr.	Symbol	Color	Description	
1	--	--	Multi-functional display	
2	F1	--	F1 (operating state indicator)	4-40
3	F2	--	F2 (maintenance meter, engine operation mode indicator)	4-40
4	F3	--	F3 (time display, automatic engine speed setting)	4-40
5		Blue	High beam	5-31
6		Green	Turn indicators	5-31
7		Red	Charge indicator light	8-1
8		Red	General vehicle malfunction	8-1
9		Yellow	Preheating	4-50
10		Red	Engine oil pressure	8-1
11		Yellow	Engine warning	8-1
12		Red	Engine stop	8-1
13		Yellow	Regeneration required	7-59; 8-1
14		Yellow	Regeneration disabled/interrupted (404F-22T)	7-59; 8-1
15		Red	Exhaust gas recirculation error Stop the vehicle and contact a Wacker Neuson service center.	--
16		--	Speed range 1	5-3
		--	Speed range 2	

nr.	Symbol	Color	Description	
17	  	--	Travel direction	5-10
		Red	Parking brake	5-7
18		--	Not assigned	--
19		--	Swiveling the boom	5-51
		Red	Hydraulic functions locked	4-51
20		--	Travel speed control (option)	5-91
		--	Additional control circuit AUX II (option)	5-47
		--	Additional control circuit AUX III (option)	5-48
21		Yellow	Exhaust gas temperature (404F-22T)	7-59; 8-1
22		Green	Parking light (only 7" multi-functional display)	5-31
23		Green	Low beam light (only 7" multi-functional display)	5-31

## Error symbols



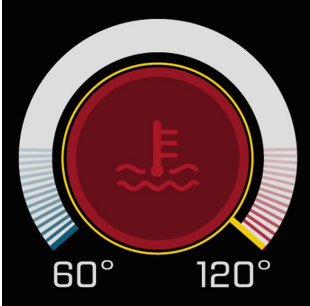

If an error occurs, the following symbols are displayed for a few seconds in the multi-functional display.

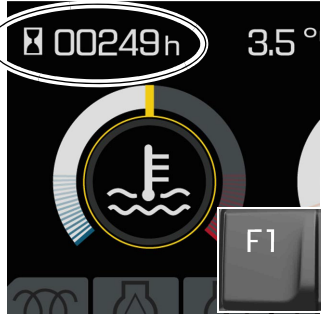
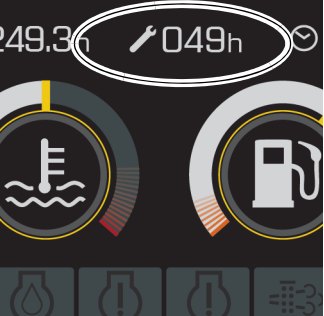
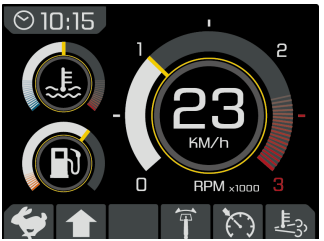
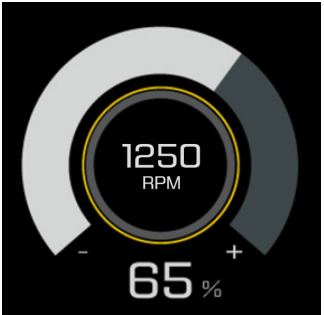
Error symbols are listed according to priority.


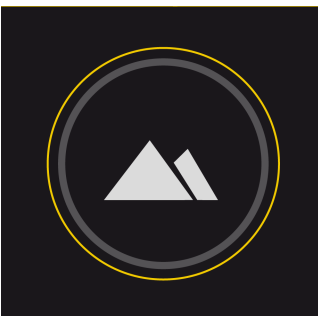

Symbol	Description	Symbol	Description
	<b>01 Brake accumulator</b> (short indication)		<b>06 Pilot pressure</b> (short indication)
	<b>02 Engine stop</b> (short indication)		<b>07 Charge indicator light</b> (short indication)
	<b>03 General malfunction</b> (short indication)		<b>08 Hydraulic oil temperature</b> (permanent indication)
	<b>04 Engine oil pressure</b> (short indication)		<b>09 Hydraulic oil filter</b> (short indication, appears again upon starting the engine)
	<b>05 Overspeed</b> (short indication)		<b>10 Air filter</b> (short indication, appears again upon starting the engine)
	<b>Hydraulic functions locked</b>	--	--

– see chapter “8.2 Malfunctions (display element/multi-functional display)” on page 8-3

## Status indicators

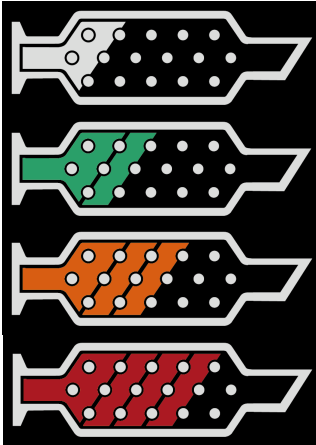
Symbol	
	<p><b>Starter/engine start</b></p> <ul style="list-style-type: none"> <li>• <b>A:</b> starting key in position 1</li> <li>• <b>B:</b> engine starts</li> </ul>
	<p><b>Engine operating mode</b>  <i>– see chapter “Engine operating mode” on page 5-2</i></p>
	<p><b>Coolant temperature</b></p> <p>If the coolant temperature is too high the symbol shown on the left appears and the buzzer sounds.</p> <ul style="list-style-type: none"> <li>• Let the engine run at high idling speed without any load.</li> <li>• Wait until the temperature drops and the indicator light goes out.</li> <li>• Stop the engine.</li> <li>• Check the coolant level.</li> </ul>
	<p><b>Fuel tank capacity</b></p> <p>Refuel if the symbol shown on the left appears.</p>

Symbol	
	<p><b>Operating states</b></p> <p>Press <b>F1</b> to toggle between the operating state displays:</p> <ul style="list-style-type: none"> <li>• Operating hours</li> <li>• Daily hours of operation</li> <li>• Engine speed</li> <li>• Outside temperature (automatic air-conditioning option)</li> <li>• Hydraulic oil temperature</li> <li>• Time</li> </ul>
	<p><b>Maintenance meter</b></p> <p>Counts the remaining engine operating hours down to the next maintenance work due.</p> <p>If less than 10 hours are displayed, the wrench symbol flashes.</p>
	<p><b>Startup screen road-travel mode</b></p> <p>Depending on machine equipment the following information is presented in road-travel mode:</p> <ul style="list-style-type: none"> <li>• Time/operating hours/daily hours of operation/hydraulic oil temperature/outside temperature</li> <li>• Coolant temperature/fuel level</li> <li>• Speed range</li> <li>• Travel direction/parking brake</li> <li>• Boom, hydraulic function</li> <li>• Travel speed control, AUX I, AUX II</li> <li>• Diesel particulate filter exhaust-gas temperature</li> </ul>
	<p><b>Engine speed</b></p> <p>This display appears when the manual throttle is used.</p>

Symbol	
	<p><b>No function</b> This symbol appears when a control element without function is operated.</p>
	<p><b>high-altitude mode</b> This display appears when starting engine above 800 m (2625 ft.) sea level (EW65 404F-22T). – see chapter “Measures when operating at great heights” on page 7-62</p>
	<p><b>Overload</b> The symbol shown on the left appears and the buzzer sounds. The permissible load diagram values are exceeded.</p> <ul style="list-style-type: none"> <li>• Reduce the load until both the buzzer and the warning light go out – see chapter “Lifting gear applications” on page 5-52.</li> </ul> <p>When the safe load indicator is switched on, the symbol is illuminated and the buzzer sounds as a functional check.</p>
	<p><b>Status indicator for 7” multi-functional display (option)</b> Additional status indicators are displayed:</p> <ul style="list-style-type: none"> <li>• Battery voltage</li> <li>• Engine oil pressure</li> <li>• Hydraulic oil temperature</li> <li>• Preset maximum flow rate of the additional control circuits AUX I through AUX III</li> </ul> <p>Use the rotary switch of the jog dial control unit to toggle between camera view and status display.</p>



**Symbol**



**DPF loads**

White: no load

Green: low load

Yellow: medium load

Red: highest load

– see chapter “Indication of load condition” on page 7-64

Adjusting the multi-functional display

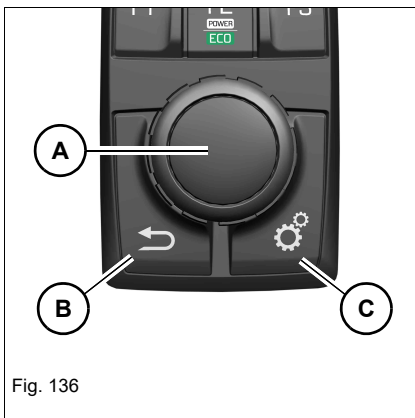
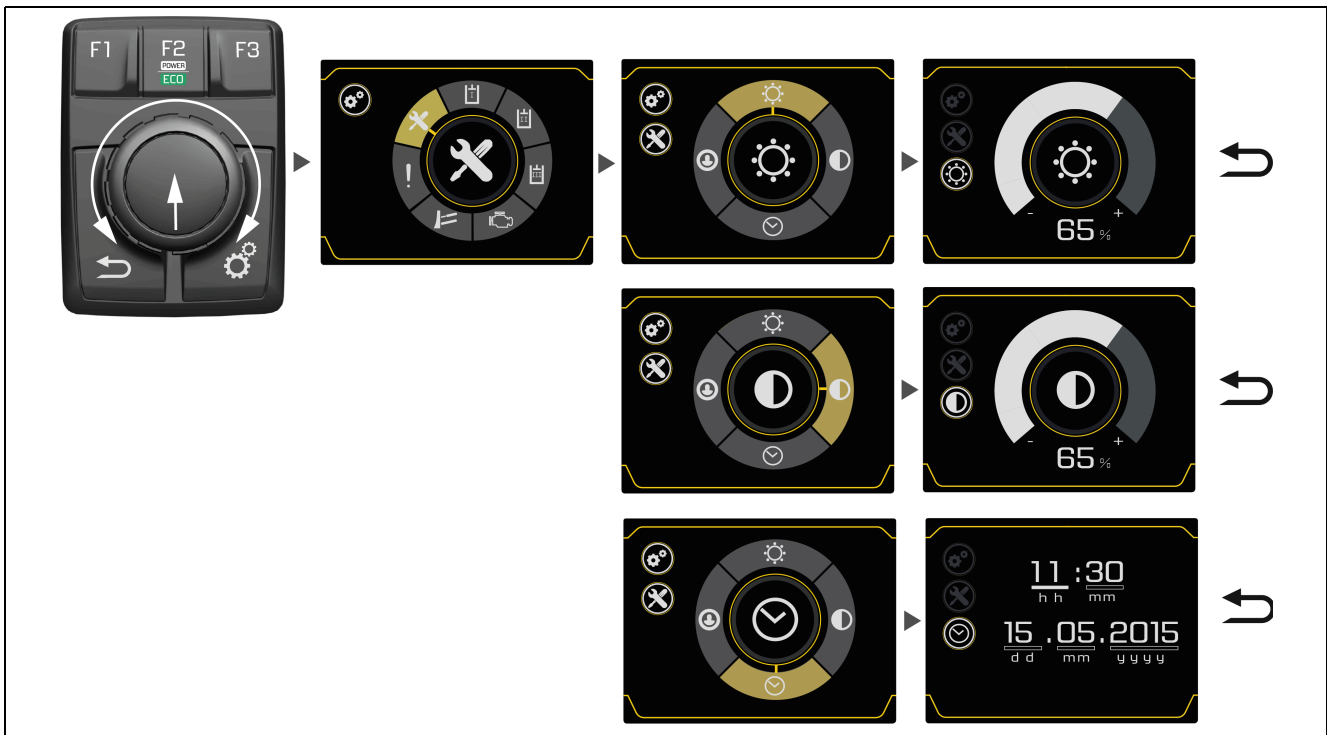


Fig. 136

**Performing the adjustments**

- Push button **C**: call the settings.
- Adjustment button **A**: select settings (turn) and confirm (press).
- Push button **B** (return): back to previous menu level.

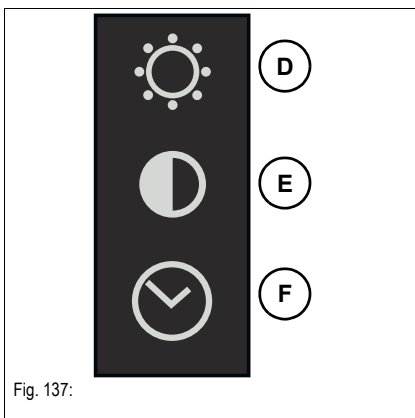


Fig. 137:

**Symbols**

- D:** Brightness
- E:** Contrast
- F:** Time/Date

## 4.4 Preparatory work

### Important notices before commissioning the machine

Perform a visual check before starting work:

- There must be no leaks.
- There must be no damaged or loose parts.
- Do not allow anyone to stay in the danger zone.

Before putting the vehicle into operation, the operator must familiarize himself with the position of the controls and instruments.

Only operate the vehicle from the seat with the seat belt fastened.

Before using the vehicle in work operation for the first time, Wacker Neuson recommends trying out the vehicle on open ground without any obstacles.

When using the vehicle, check the surroundings constantly in order to identify potential hazards in time.

Before starting work, ensure that all visual aids are clean, functional and adjusted in accordance with the instructions in this Operator's Manual.

The operator must follow the national and regional regulations.

Perform a **functional check of the control lever base**.

Perform a **functional check of the safe load indicator**.

Do not make any modifications that impair visibility. The vehicle does not meet the requirements for conformity and registration.

Observe the safety instructions – [see chapter "2.4 Operation" on page 2-4](#).

### Requirements and information for the operating personnel

Read, understand and follow this Operator's Manual and all other Operator's Manuals supplied with the vehicle.

The vehicle may only be put into operation by authorized personnel that has been instructed – [see chapter "2.3 Conduct" on page 2-3](#).

The operator must know and bear in mind the requirements and risks at the work place.

Perform daily maintenance according to the Lubrication and maintenance plan (see chapter "**Maintenance 7.2**")

Face the vehicle as you enter and exit it, and only use the mandatory climbing aids for entering and exiting.

Keep the footholds and the handholds clean to ensure a safe hold at all times. Immediately remove dirt, oil, snow, etc.

Do not get on a moving vehicle, or jump off it.

Do not operate the vehicle if the standard protective equipment (e.g. the cabin) has been removed.

No clothes or parts of the body may protrude outside the vehicle during operation.

### Check lists

The checklists below assist you in checking and monitoring the vehicle before, during, and after operation.

Wacker Neuson does not claim those lists to be exhaustive.

If the answer to one of the questions is **No**, first rectify the cause of the fault (or have it rectified) before starting work.

The checking and monitoring work listed below is described in greater detail in the following chapters.

**Start-up checklist**

Check and observe the following points before putting the vehicle into operation or starting the engine:

<b>nr.</b>	<b>Question</b>	<b>Page</b>
1	Enough fuel in the tank?	<a href="#">7-33</a>
2	Water drained from the water separator?	<a href="#">7-37</a>
3	Correct engine oil level?	<a href="#">7-41</a>
4	Coolant level OK?	<a href="#">7-44</a>
5	Correct oil level in the hydraulic oil reservoir?	<a href="#">7-48</a>
6	Glass cleaner in washer reservoir?	<a href="#">7-53</a>
7	Lubrication points greased?	<a href="#">7-9</a>
8	Tracks checked for cracks, cuts, etc.?	--
9	Light system, mirrors, signaling, warning and indicator lights operational and/or adjusted correctly?	--
10	Windows, visual aids, lights, steps, all pedals and control levers clean?	--
11	Does the steering system work properly?	--
12	Service and parking brake operational?	<a href="#">5-6</a>
13	Service brake locked?	<a href="#">5-6</a>
14	Machine and tires clean, without any stones or pebbles between the twin tires (road travel)?	--
15	Stabilizer blade(s) and stabilizer legs clean (road travel)	--
16	All control levers and pedals in neutral position?	--
17	Does the window washing system function correctly?	--
18	Control lever base raised?	--
19	Are other persons required to guide you?	--
20	Attachment safely locked?	<a href="#">5-60</a> <a href="#">5-79</a>
21	Engine cover locked? Filler cap closed tightly?	<a href="#">7-26</a> <a href="#">7-33</a>
22	Tools and other loose objects removed?	--
23	Seating position adjusted correctly?	<a href="#">4-10</a> <a href="#">4-13</a>
24	Are all visual aids functional, clean and adjusted correctly?	<a href="#">4-18</a> <a href="#">4-21</a>
25	Seat belt fastened?	<a href="#">4-17</a>



### Operation checklist

Check/observe the following before beginning operation or after starting the engine:

nr.	Question	Page
1	Are there any persons or objects in the danger zone of the vehicle?	5-80
2	All indicator lights gone out?	4-36
3	Coolant temperature of engine in normal range?	4-36
4	Do the pedals and control levers work correctly?	--
5	Performed functional check of control lever base?	4-51
6	Perform a functional check of the safe load indicator.	5-52
7	Braking effect sufficient?	5-7

### Parking checklist

Check and observe the following points when parking the vehicle:

nr.	Question	Page
1	Attachment lowered to the ground?	5-60 5-79
2	Forward-reverse control in neutral position?	5-10
3	Parking brake applied?	5-7
4	Service brake locked?	5-6
5	Stabilizer legs/blade lowered to the ground?	5-42
6	Control lever base raised?	4-51
7	Cabin locked?	4-2

#### When parking on public roads:

8	Machine appropriately secured? Machine secured with wheel chocks in addition to prevent it from rolling away?	5-27
---	--	------

#### When parking on slopes:

9	Machine secured with wheel chocks in addition to prevent it from rolling away?	5-27
---	--	------

## Putting into operation for the first time and running-in period

Before putting the vehicle into operation for the first time, check whether the equipment supplied with the vehicle is complete.

- Check the fluid levels according to chapter “**Maintenance**”.

Each vehicle is correctly adjusted and checked before it is delivered.

After ten hours of operation, check wheel nuts for tightness.

Handle the vehicle carefully during its first 50 operating hours.

- Do not load a cold engine.
- Warm up the vehicle at low engine speed and little load, do not warm it up at a standstill.
- Do not change engine speed abruptly.
- Avoid using the vehicle under heavy loads or at high speeds.
- Avoid abrupt acceleration, braking and changing travel direction.
- Do not run the engine at high speed for extended periods.
- Observe the maintenance plans – *see chapter “7.2 Maintenance overview” on page 7-2.*

## Machine travel on public roads

- The machine is subject to the applicable legal regulations of your country.
- Safety equipment in compliance with the legal regulations of your country must be on board, for example a warning triangle, a first aid kit and a safety vest.
- Follow the national accident prevention regulations and the following instructions:
- Adapt the travel speed to the road and ground conditions, machine handling and to the visibility conditions.
- Do not perform machine travel any faster than 20 kph (12.4 mph).
- Before performing machine travel on public roads, remove the protective Front Guard structure.
- All attachments except backhoe buckets up to 650 mm (26 in) wide must be removed.
- Empty the bucket.
- Do not switch on working lights when driving on public roads.
- Perform a functional check of the lights (headlights, turn indicators, etc.).
- Perform a functional check of the braking system.
- Ensure that the machine has no leaks.
- Keep the door and the windows closed.
- Fasten your seat belt.
- Prepare the machine for driving on public roads – *see chapter “Preparing machine travel on public roads” on page 5-13*

## 4.5 Starting and stopping the engine

### Preparatory work

#### **WARNING**

##### **Accident hazard due to unintentional operation of the vehicle!**

Unintentional operation can cause serious injury or death.

- ▶ Only operate the vehicle from the seat with the seat belt fastened.

The starter cannot be actuated if the engine is already running (start repeat interlock).

Do not run the starter for more than 20 seconds.

Wait two minutes so the battery can recover and the starter does not overheat before trying again.

#### **Information**

Provide for sufficient ventilation when operating in enclosed areas.

#### **Information**

All controls must be within easy reach. You must be able to move the drive levers to their limit positions.

### Starter

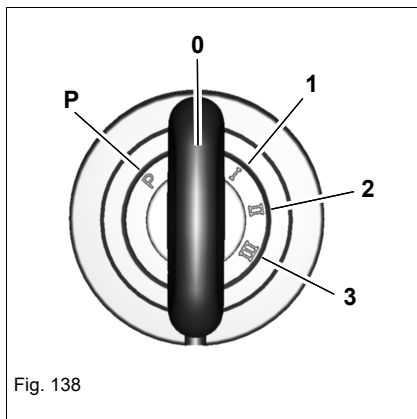


Fig. 138

Position	Function	
P	Park position	Not assigned
0	Stop position	Insert or remove the starting key
1	Machine travel position	All electric functions are enabled
2	Preheats the engine	Preheater active
3	Starts the engine	Starter is actuated

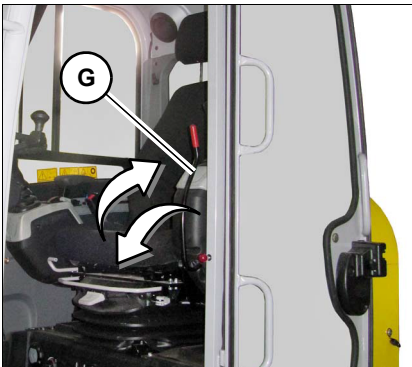


**Starting and stopping the engine**


Fig. 139 (symbolic representation)

Control lever base	Indication	Effect
Raised		The engine can be started
Lowered		The engine cannot be started

All hydraulic functions are locked if the control lever is raised with a running engine.

**Functional check of joystick base**

Before starting work, perform a functional check of the control lever base.

1. Start the vehicle.
2. Fold the control lever base **G** down.
3. Perform vehicle travel on open terrain.
4. Secure the danger zone.
5. Stop the vehicle.
6. Raise the control lever base **G**.
7. Move all control levers and pedals in all directions.
  - The selected elements do not move:
    - Work may be performed with the vehicle.
  - The selected elements move:
    - Stop operation immediately.

Contact a Wacker Neuson service center and have the malfunction rectified.

**NOTICE**

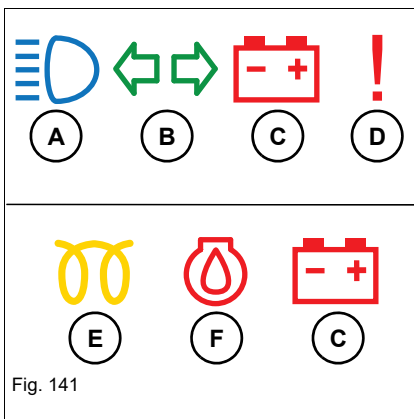
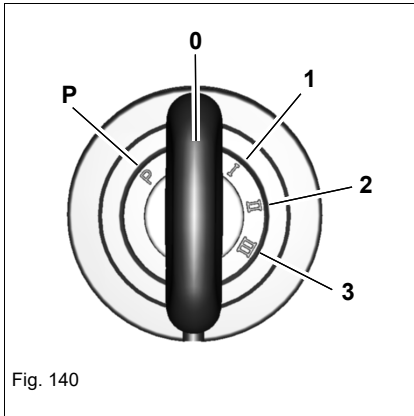
Possible damage if the engine is started again immediately after stopping it.

- ▶ Wait at least 2 minutes before starting the engine again.

**NOTICE**

Possible damage to preheater if the preheating system is operated too long.

- ▶ Do not preheat the engine for more than 5 seconds.



1. Insert the starting key.
2. Turn the starting key to position **1**.
3. Indicator lights **A – D** are illuminated for a few seconds.
  - ➔ If an indicator light does not function, contact a Wacker Neuson service center.
4. Turn and hold the starting key in position **2** until the indicator light for **preheating (E)** goes out.
  - ➔ The indicator lights **engine oil pressure (F)** and **alternator charging (C)** are illuminated.
5. Turn the starting key to position **3** until the engine runs.
  - ➔ All indicator lights go out.
  - ➔ If the engine does not start after 20 seconds:
    - ➔ Interrupt the start procedure and repeat it after 2 minutes.
    - ➔ If the engine still does not start after a few tries, contact a Wacker Neuson service center and have the error rectified.
6. As soon as the engine runs:
  - ➔ Release the starting key.

### Warm-up phase of vehicle

After the engine has started, allow it to warm up at slightly increased idling speed until the coolant reaches its operating temperature of about 80°C (176°F).

Do not let the vehicle warm up at standstill.

Check for unusual noise, exhaust color, leaks, malfunctions, or damage.

In case of malfunctions, damage, or leaks:

Secure the vehicle, park it and find out the cause for the damage and have it repaired.



### Information

Raise the control lever base **G** after stopping the engine.

---

## Starting aid

---

 **WARNING****Explosion hazard in case of incorrect handling of battery!**

Incorrect battery handling can cause serious injury or death.

- ▶ Wear protective equipment.
  - ▶ Fire, open flames and smoking is prohibited
  - ▶ Do not jump start the engine if the battery is malfunctioning or frozen, or if the acid level is too low.
- 

---

 **WARNING****Injury hazard due to rotating parts!**

Rotating parts can cause serious injury or death.

- ▶ Open the engine cover only at engine standstill.
- 

---

 **CAUTION****Burn hazard due to hot surfaces!**

Can lead to severe burns or even death.

- ▶ Stop the engine and let it cool down.
  - ▶ Wear protective equipment.
- 

---

**NOTICE**

Possible damage due to electrical short circuit or over-voltage.

- ▶ The positive terminal of the starting battery must not be brought into contact with electrically conductive vehicle components.
  - ▶ The vehicles must not touch each other during the starting aid.
  - ▶ If the engine still does not start despite a starting aid, contact a Wacker Neuson service center.
-



---

### **NOTICE**

Possible damage due to wrong battery voltage.

- ▶ Only use batteries with the same voltage (12 V).

---

### **NOTICE**

Possible damage to vehicle with empty battery due to voltage peaks.

---

### **NOTICE**

Possible damage to battery jumper cables when placing them near rotating parts.

- ▶ Do not place the battery jumper cables near rotating parts.



### **Information**

Use only authorized battery jumper cables which conform to national and regional safety requirements.

---

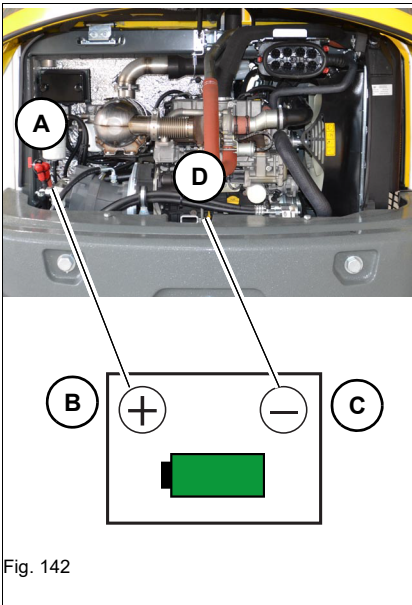


Fig. 142

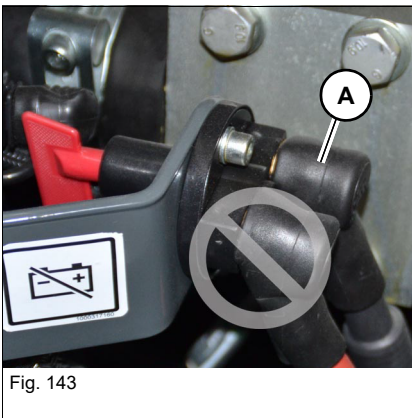


Fig. 143

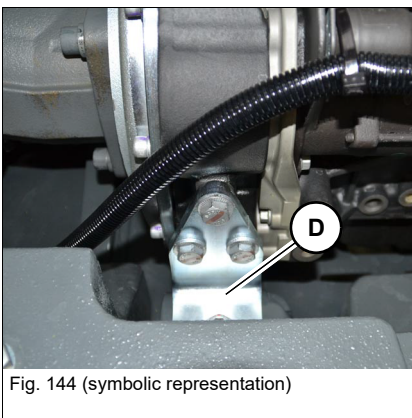



Fig. 144 (symbolic representation)

Designations/symbols	Meaning
<b>X</b>	Machine with empty battery
<b>Y</b>	Vehicle with full battery
<b>A</b>	Positive/vehicle <b>X</b>
<b>B</b>	Positive/vehicle <b>Y</b>
<b>C</b>	Negative/vehicle <b>Y</b>
<b>D</b>	Negative/vehicle <b>X</b>
	Full battery

1. Move vehicle **Y** close to machine **X** so that the length of the battery jumper cables is sufficient.
2. Stop the engine of vehicle **Y**.
3. Open the engine covers of both vehicles.
4. Connect the battery jumper cables in the following order: **A-B/C-D**.
5. Start the engine of vehicle **Y**.
6. Wait 5 minutes for the empty battery to be charged a little.
7. Start the engine of machine **X**.
8. Switch on the boom light of vehicle **X** in order to avoid voltage peaks and to protect the electronic system.
9. Disconnect the battery jumper cables in the following sequence: **D-C/ B-A**.

### Low-load operation

---

**NOTICE**

Possible damage to the engine due to low-load operation.

- ▶ Run the engine at idling speed or at high engine speed at over 20% engine load.

---

Possible consequences of low-load operation are:

- Increased engine oil consumption.
- Dirt in engine due to engine oil in exhaust system.
- Blue smoke in exhaust gas.
- Shorter diesel particulate filter regeneration cycles.

### Stopping the engine

---

**NOTICE**

Possible damage to the engine when it is stopped after running under high load.

- ▶ Letting the engine run at idling speed before stopping it avoids engine damage and increases the engine's service life.

- 
1. Let the engine run at idling speed for five minutes without any load.
  2. Turn the starting key to "0" and remove it.

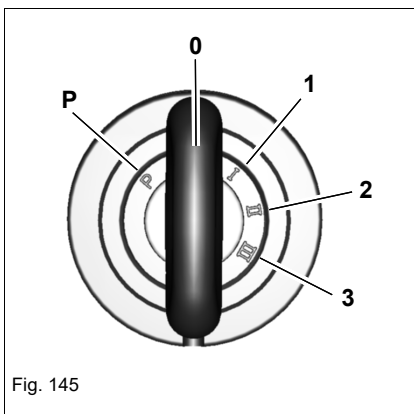


Fig. 145

## Battery master switch

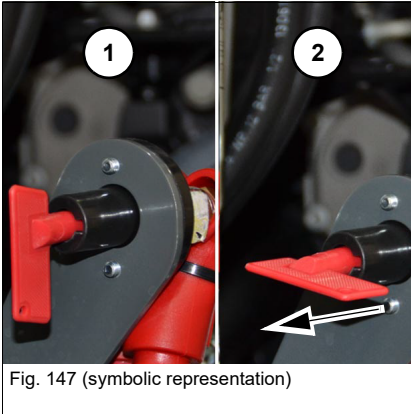
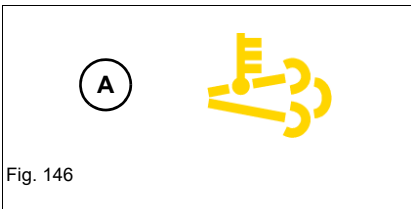
### NOTICE

Possible damage to the electronics due to improper actuation of the battery master switch.

- ▶ Do not operate the battery master switch with a running engine.
- ▶ After the **increased exhaust-gas temperature (A)** indicator light goes out, activate the battery isolator switch after 15 minutes at the earliest.
- ▶ Operate the battery master switch no sooner than two minutes after shutting down the engine.

Actuate the battery isolator switch:

- If the vehicle is parked for longer periods of time (e.g. over the weekend).
- If the vehicle is to be protected against unintentional taking into service.
- If required by national and regional provisions.



The battery master switch is located on the left in the engine compartment.

Power supply	Key position
Established	1
Interrupted	2 (key removed)



Notes:

## 5 Operation

### 5.1 Steering system

The steered axle is the front axle.

### 5.2 Accelerator actuation

#### Manual throttle

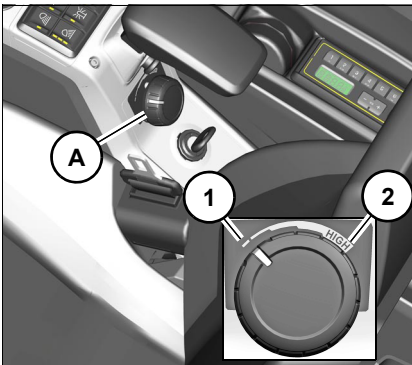


Fig. 148

#### Variant 1

Engine speed can be set continuously with governor **A**.

Engine speed	Position
Idling speed	1
Maximum	2



Fig. 149

#### Variant 2

Engine speed can be set continuously with governor **A**.

Engine speed	Direction of rotation
Increase	Clockwise
Reduce	Anticlockwise

#### Accelerator pedal

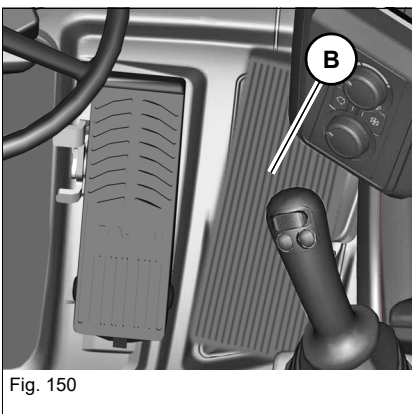


Fig. 150

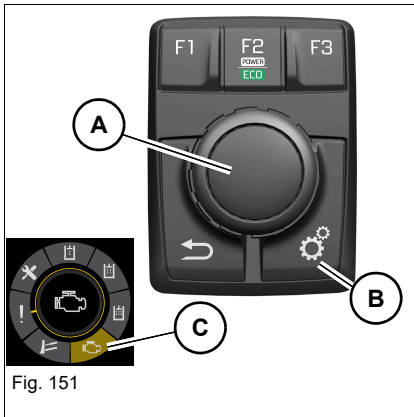
The effect of actuating accelerator pedal **B** depends on the mode.




Mode	Effect
Operating mode	Constant engine speed via the manual throttle. The accelerator pedal controls the traveling drive.
Road-travel mode	Automotive travel: the accelerator pedal controls the engine speed and the traveling drive.

Changing over to road-travel mode switches the engine to idling speed.

Position	Effect
Press accelerator pedal <b>B</b> fully	Maximum engine speed
Do not press accelerator pedal <b>B</b>	Idling speed

## Engine operating mode



Engine operating mode	Application
	For powerful and fuel-efficient operation
	Maximum power
	High-altitude mode (404F-22T)

### Information

The high-altitude mode is activated automatically. It is not possible to switch over to a different motor operating mode.

### Changing the engine operating mode directly

Press touch button **F2**.

### Presetting the engine operating mode

1. Press menu button **B**.
2. Press control button **A** to select menu item **Engine Operating Mode C**.
3. Press control button **A**.
4. Turn control button **A** to select the required operating mode (ECO/PWR).
5. Press control button **A**.

The engine starts up in the selected operating mode.



### Information

The high-altitude mode cannot be preset.



## Speed range selection (option)

---



### **WARNING**

**Accident hazard! Do not perform machine travel any faster than 30 km/h (19 mph).**

Can cause serious injury or death.

- ▶ Control the speed with the accelerator pedal or service brake.
- 

### **NOTICE**

In case of a 30 kph machine, change speed ranges only at machine standstill in order to avoid damage to the traveling drive. Press the service brake.

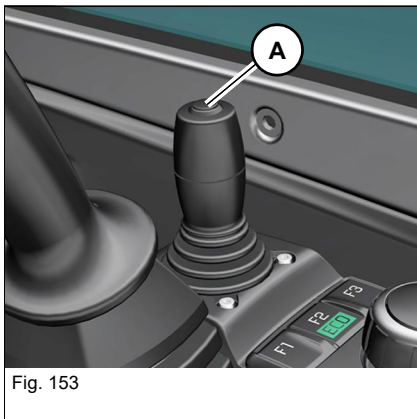
---



### **Information**

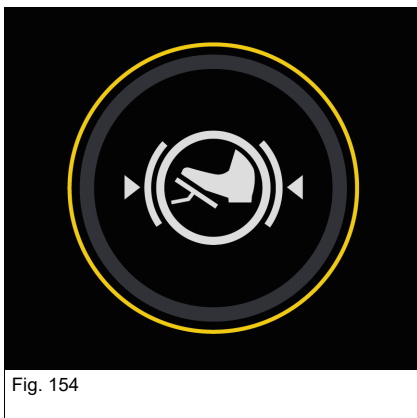
In case of a 20 kph machine, the speed ranges can be changed during machine travel.

---



The machine has less tractive power in speed range 2.  
 The speed can be selected with touch button **A** on the dozer blade lever.

Speed range selection	Push button	Indication
Speed range 1		
Speed range 2		



**Changing speed ranges (30 kph version)**

1. Bring the machine to a standstill.
2. Change the speed range with push button **A**.
  - The symbol on the left appears as long as the service brake is not pressed.
3. Press the service brake.
4. The symbol goes out.
  - The corresponding speed-range symbol appears.

**Changing speed ranges (20 kph version)**

1. Change the speed range with push button **A**.

### Automatic engine speed setting

If the hydraulic system is not operated for a few seconds, the diesel engine goes into idling speed

If the hydraulic system is operated, the diesel engine runs at the engine speed set with the manual throttle.

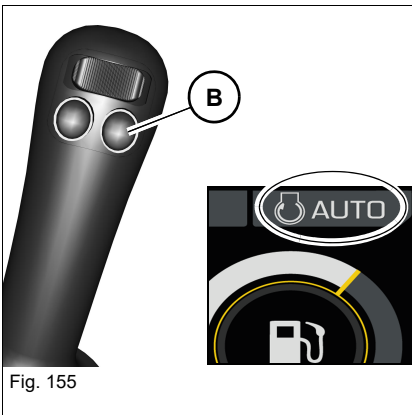
The automatic engine speed setting can be switched on and off using the touch button **F3** on the jog dial.

Automatic engine speed setting	Push button	Indication
On		
Off		--

### Changing engine speed manually

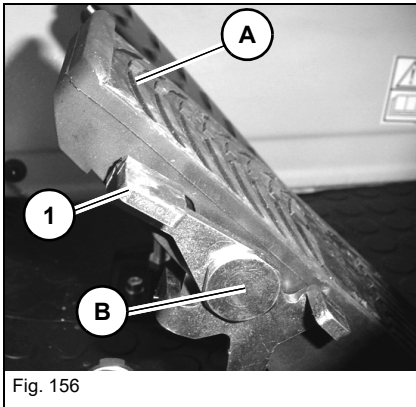
Push button **B** on the left control lever makes it possible to toggle between the idling speed and the engine speed set with the manual throttle at any time.

The selected symbol flashes while the engine is in idling speed.



## 5.3 Brakes

### Locking the service brake



#### **WARNING**

##### Accident hazard due to abrupt braking!

Service brake **A** can engage if it is fully pressed. Braking at full speed can cause serious injury and death.

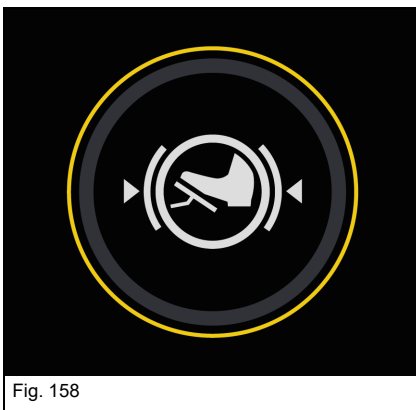
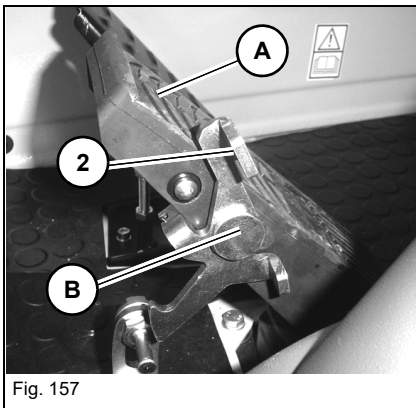
- ▶ Always set release lever **B** to position **1** before performing machine travel.

Fully press service brake **A** to lock it. This prevents gearbox interaction and locks the oscillating axle.

The road-travel mode cannot be selected if the service brake is locked.

#### Release lever

Function	Position
Road-travel mode The fully pressed service brake does not engage in the final position.	1
Operating mode The fully pressed service brake engages in the final position.	2



#### **Information**

The symbol shown on the left appears in the multifunctional display in the following cases:

- ▶ when the service brake is locked.
- ▶ when the accelerator pedal is operated while the service brake is locked.



Fig. 159

## Overspeed

### NOTICE

Possible engine damage due to high engine speed.

- ▶ If the **Overspeed** symbol illuminates, reduce the engine speed immediately with the service brake until the symbol goes out.

When driving downhill, the engine brake is no longer sufficiently effective from 2200 min<sup>-1</sup> (rpm) in work mode and 2800 min<sup>-1</sup> (rpm) in road mode. The symbol shown on the left appears.

Reduce the engine speed with the service brake until the symbol goes out.

## Parking brake

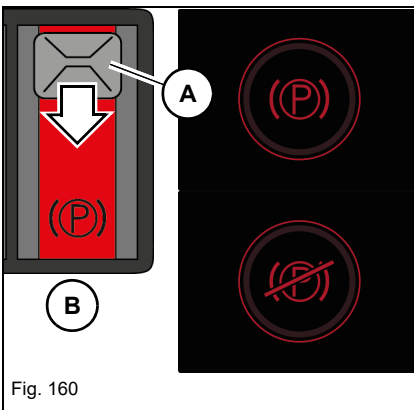


Fig. 160

Enable:

1. Pull lock **A** down.
2. Press switch **B** down.
  - ➔ The corresponding symbol appears in the multifunctional display.

## Hydraulic brake

The machine slows down when the accelerator pedal is released.



### Information

Reduce the speed with the accelerator pedal, and not with the manual throttle.



### Mechanical brake

The stabilizer blade is used as an additional parking brake. Press the stabilizer blade against the ground.

### Brake test



#### Information

Do not put the vehicle into operation if a brake test gives a negative result or if there are doubts as to the correct brake function. Contact a Wacker Neuson service center and have the malfunction rectified.

The following tests help check the brake function. If possible, always park the machine without any load and on firm, level and horizontal ground, and secure it with suitable means (for example with chocks).

Perform the brake tests once a day on firm, level and horizontal ground.

#### Parking brake test

Put the machine in road-travel mode so the front wheels can be fully seen. With the parking brake applied, turn the steering wheel several times to the left and right limits.

➔ Steering requires more effort, and the front-axle wheels block.

#### Service brake test

Start machine travel in speed range 1 and press the service brake.

➔ Deceleration must be stronger than when only releasing the accelerator pedal.

## 5.4 Machine travel

There are two different operating modes:

- **Operating Mode**  
Includes all work (for example moving earth, gravel or rubble) that may be performed with the machine, and hammer operation.
- **Road-travel mode**  
Designates machine travel on public roads. No work may be performed in road-travel mode. In road-travel mode, specific measures must be taken for preparing machine travel on public roads – *see chapter “Preparing machine travel on public roads” on page 5-13.*



### **WARNING**

#### **Accident hazard due to incorrect vehicle operation!**

The machine moves in the opposite direction if the upper carriage is rotated by 180° and the accelerator pedal is actuated.

Incorrect operation can cause serious injury and death.

- ▶ Actuate the accelerator pedal slowly and carefully.
- ▶ Bear in mind the reversed steering direction.



### **WARNING**

#### **Accident hazard due to incorrectly rotated upper carriage!**

If rotated incorrectly, the upper carriage blocks the visibility of the travel path. This may cause serious injury or death.

- ▶ Before starting vehicle travel on a construction site, align the upper carriage so that the operator has an unrestricted view of the travel path.
-



### Forward-reverse control

---

 **WARNING**

**Accident hazard due to incorrect adjustment of travel direction!**

Can cause serious injury and death.

- ▶ Ensure that the surrounding area is clear.
  - ▶ Set the forward-reverse control to the required position before starting machine travel.
- 

 **WARNING**

**Accident hazard when changing over the travel direction during machine travel!**

Can cause serious injury and death.

- ▶ Change over the travel direction only at machine standstill.
- 

**NOTICE**

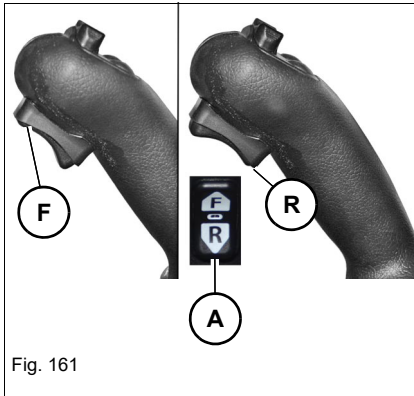
Possible damage when changing over travel direction during machine travel.

- ▶ Do not operate the forward-reverse control during machine travel.
  - ▶ Change over the travel direction only at machine standstill.
- 




**NOTICE**

Possible damage due to incorrect adjustment of travel direction.

- ▶ Ensure that the surrounding area is clear.
  - ▶ Set the forward-reverse control to the required position before starting machine travel.
-



The forward-reverse control is located on the joystick on the right.

Travel direction	Position	Indication
Forward	<b>F</b>	
Neutral position	<b>N</b>	
Reverse	<b>R</b>	

The travel directions **F** and **R** are additionally illustrated on the inside **A** of the forward-reverse control.

The travel direction does not change if road-travel mode is changed to operating mode and back again.

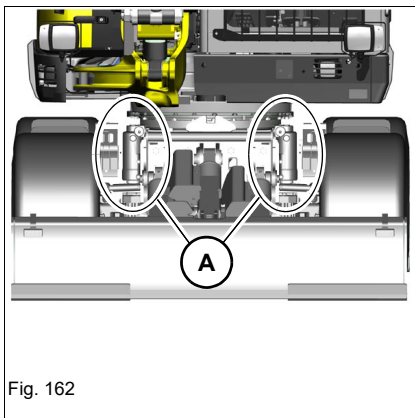
## Starting machine travel (operating mode)

### **WARNING**

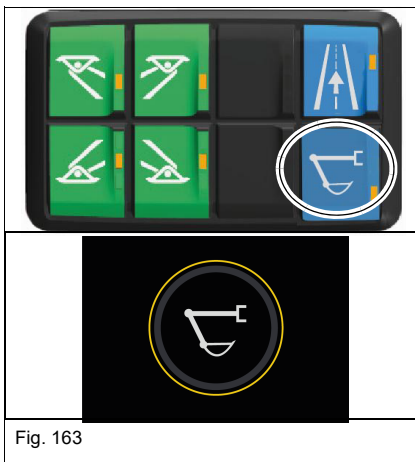
#### Accident hazard due to incorrectly rotated upper carriage!

If rotated incorrectly, the upper carriage blocks the visibility of the travel path.

- ▶ Before starting vehicle travel on a construction site, align the upper carriage so that the operator has an unrestricted view of the travel path.



The front side of the machine is the one with the oscillating axle cylinders **A**.



1. Raise the control lever base.
2. Start the engine – see chapter “Starting and stopping the engine” on page 4-51.
3. Position the upper carriage straight ahead.
4. Lock the service brake.
5. Fold the control lever base down.
6. Set the manual throttle to idling speed position.
7. Move the forward-reverse control to the neutral position.
8. Release the parking brake.
9. Check the steering direction.
10. Raise the attachment and the stabilizer legs or blade.
11. Select the 1st speed range.
12. Release the service brake.
13. Press the **Operating mode** button.
  - The operating mode symbol appears.
14. Move the forward-reverse control to the required position.
15. Press accelerator pedal slowly.
  - If vehicle travel does not start, increase the speed with the manual throttle.

Lock the upper carriage when performing machine travel over longer distances – see chapter “Installing the rotation interlock on the upper carriage” on page 5-15.

## Preparing machine travel on public roads

Note – see chapter “*Machine travel on public roads*” on page 4-49.  
Perform the following points before changing over to road-travel mode.

### **WARNING**

#### **Injury hazard due to rotating parts!**

Unsecured machine parts can cause serious injury or death during machine travel on public roads.

- ▶ Apply the parking brake.
- ▶ Lock the service brake.
- ▶ Stop the engine.
- ▶ Raise the control lever base.
- ▶ Remove the starting key and carry it with you.
- ▶ Secure the machine against unintentional movement and unauthorized use.
- ▶ Do not allow anyone to stay in the danger zone.

### **Information**

Stop the engine before leaving the cab – see chapter “*Parking the machine*” on page 5-27.

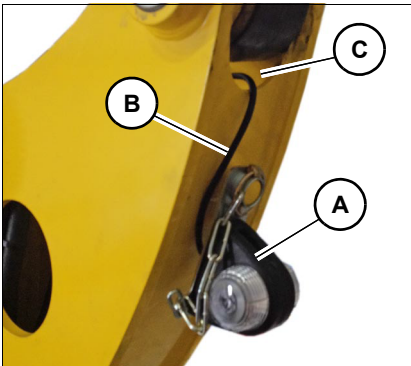


Fig. 164

#### **Installing the light on the stick**

The light kit is located in the tool kit below the access.

1. Install clearance light **A** on the shovel arm.
  2. Secure the bracket with a split pin.
  3. Insert electric line **B** through opening **C** on the boom.
- 
4. Connect electric line **B** to connector **D** on the shovel arm.

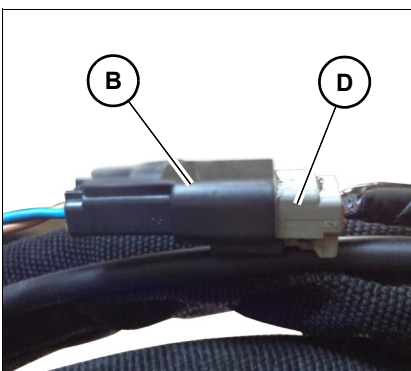
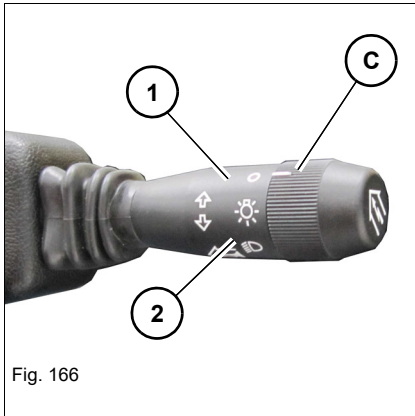
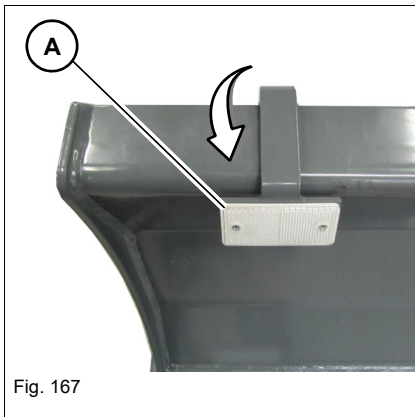


Fig. 165

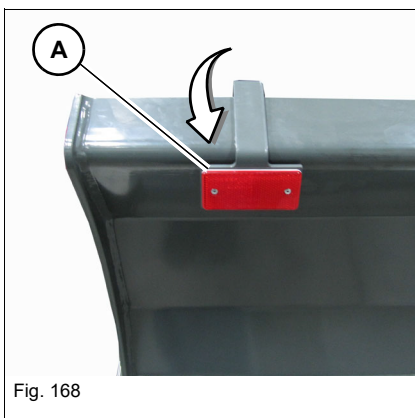


Turn rotary switch **C** to position **2**.



**Fold the reflectors outward at the front of the stabilizer blade**

1. Fold the left and right reflectors **A** outward.
2. Raise the stabilizer blade completely.



**Fold the reflectors outward at the rear of the stabilizer blade**

1. Fold the left and right reflectors **A** outward.
2. Raise the stabilizer blade completely.

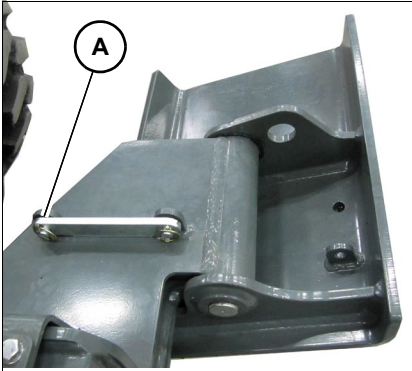


Fig. 169

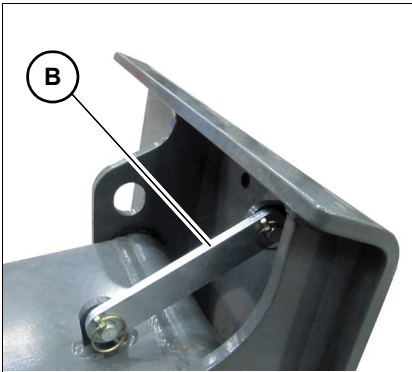


Fig. 170

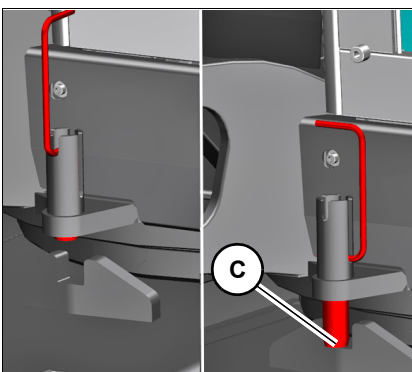


Fig. 171

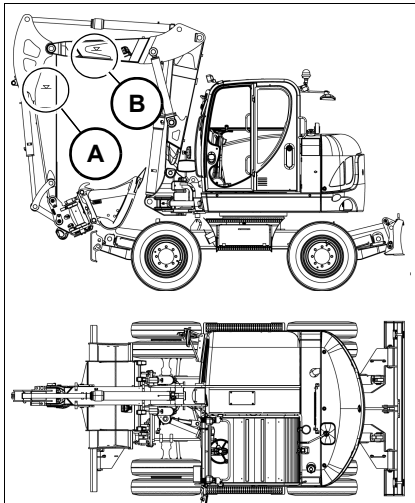
**Installing the interlock for the front and rear stabilizer legs**

1. Remove the split pins and pins **A** on the left and right.
2. Raise interlock **B**.
3. Secure the stabilizer legs with split pins and pins **A** on the left and right.
4. Raise all stabilizer legs completely.

**Installing the rotation interlock on the upper carriage**

The rotation interlock is located in the tool kit below the access.

1. Position the upper carriage straight ahead.
2. Switch off the engine and raise the control lever base.
3. Install the rotation interlock as shown. The pin should be in guide **C**.



The machine can be fitted with a triple articulation boom or one-piece boom.

### Triple articulation boom

1. Empty the attachment.
2. Position the triple articulation boom and stick so that the alignment marks are parallel to the ground.
  - **A:** Stick
  - **B:** Triple articulation boom
3. Set down the attachment as shown on the left.

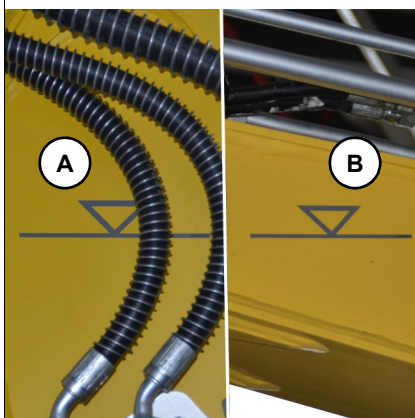
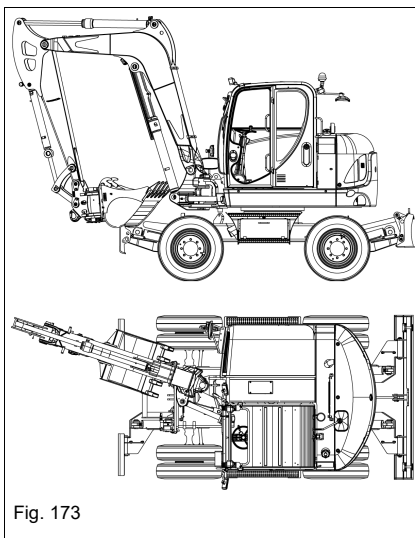


Fig. 172



### One-piece boom

1. Empty the attachment.
2. Set down the boom and attachment as shown.

Fig. 173

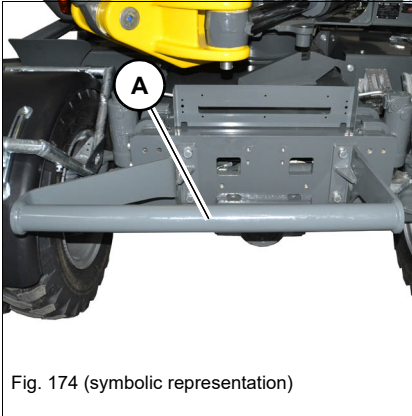


Fig. 174 (symbolic representation)

**Grab**

If a grab is installed on the machine, it has to be emptied, and hitched and closed on transport bar **A** for machine travel on public roads.

**i** **Information**

If no transport bar is installed on the machine, remove the grab before performing machine travel on public roads.

**Front parallel stabilizer blade (option)**

If the machine is equipped with a parallel dozer blade at the front, raise the dozer blade 20 cm (8 in) – see [Fig. 177](#) – by means of the marks on the blade and rod before performing machine travel on public roads. This does not cover the headlights.

---

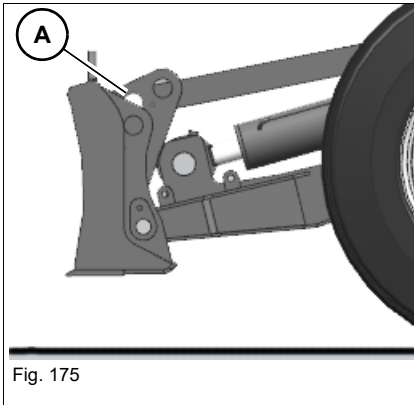
 **WARNING****Crushing hazard during lowering of stabilizer blade!**

Lowering the stabilizer blade can cause serious injury or death.

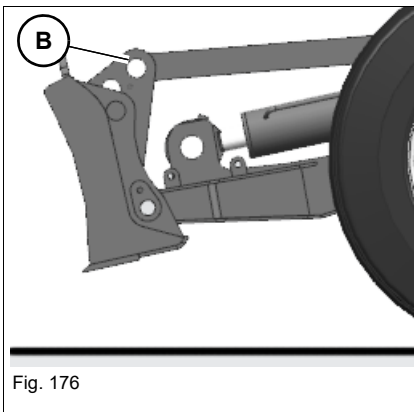
- ▶ Do not allow anyone to stay in the danger zone.
  - ▶ Interrupt work immediately if someone enters the danger zone.
- 

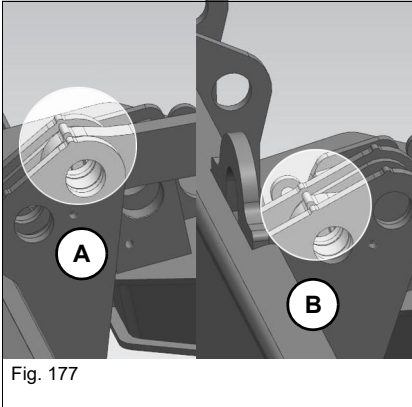
The stabilizer blade can be set to two angles.

- Mark **A** – dozer blade parallel to the ground.



- Mark **B** – dozer blade at an angle to the ground.





Set the stabilizer blade to the required angle:

1. Secure the danger zone.
2. Start the vehicle.
3. Carefully lower the stabilizer blade so that the marks on it are aligned with the mark on the rod as shown.
  - Mark **A**: dozer blade parallel to the ground.
  - Mark **B**: dozer blade at an angle to the ground.
4. Apply grease to the pins and rods before inserting them.
5. Stop the engine. Raise the control lever base.
6. Insert the pins.

**Remove the front guard** – see chapter “*Protective Front Guard structure category II (option)*” on page 4-27.

**Select speed range 1** – see chapter “*Speed range selection (option)*” on page 5-3

**Unlock the oscillating axle** – see chapter “*Locking/unlocking the oscillating axle*” on page 5-21

## Starting machine travel (road-travel mode)

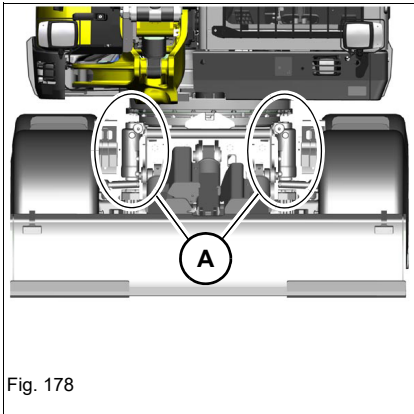


Fig. 178

The front side of the machine is the one with the oscillating axle cylinders **A**.

### **i** Information

Secure the machine accordingly before changing over to road-travel mode – see chapter “Preparing machine travel on public roads” on page 5-13.

### **i** Information

Raise the attachment so that the headlights are not covered by it.

### **i** Information

All work functions are disabled in road-travel mode.

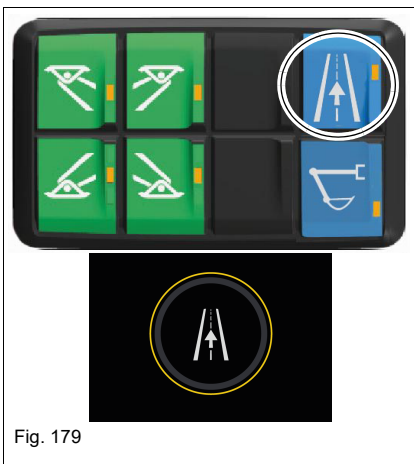


Fig. 179

1. Raise the control lever base.
2. Start the engine – see chapter “Starting and stopping the engine” on page 4-51.
3. Position the upper carriage straight ahead.
4. Lock the service brake.
5. Fold the control lever base down.
6. Move the forward-reverse control to the neutral position.
7. Release the parking brake.
8. Check whether the steering direction changeover is disabled.
  - Take care not to cover the lights with attachment and the stabilizer legs/blade as you raise them.
9. Release the service brake
10. Unlock the oscillating axle otherwise changeover to road-travel mode is not possible.
11. Press the **Road-travel mode** push button.
  - The road-travel mode symbol appears.
12. Move the forward-reverse control to the required position.
13. Press accelerator pedal slowly.
  - Machine travel starts.

## Steering mode

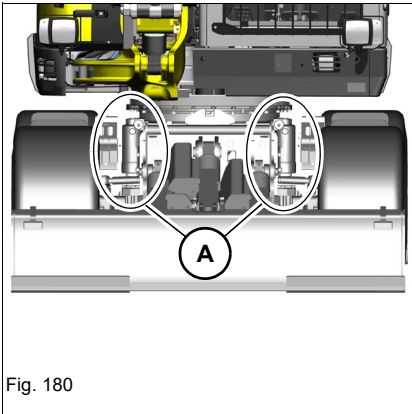


Fig. 180

The steered axle is the front axle. It can be recognized by the oscillating-axle cylinders **A**.

## Locking/unlocking the oscillating axle

The oscillating-axle interlock increases machine stability during work operation. The front axle can be locked at any possible angle.

---

### **WARNING**

#### **Tipping hazard due to unlocked oscillating axle during operation!**

A tipping vehicle can cause serious injury or death.

- ▶ Lock the oscillating axle during work with the machine.
- ▶ Lock the oscillating axle only on firm ground.
- ▶ Only work in operating mode and move loads with the oscillating axle locked
- ▶ Unlock the oscillating axle only when the boom is lowered.

---

### **WARNING**

#### **Accident hazard due to unlocked oscillating axle during machine travel on public roads!**

An oscillating axle can cause serious injury or death during machine travel on public roads if it is not unlocked.

- ▶ Unlock the oscillating axle during machine travel on public roads.
  - ▶ Unlock the oscillating axle if the machine travels over a distance longer than the boom reach.
-

**NOTICE**

Damage to the axle or machine chassis due to torsion.

► Lock the oscillating axle only on firm ground.

In road-travel mode the oscillating axle cannot be locked.

Trying to activate the oscillating-axle interlock in road-travel mode has no effect. If operating mode is selected, the switch has to be turned off and on again first to enable the oscillating-axle interlock.

**Locking the oscillating axle with the service brake**

When working at machine standstill, lock the oscillating axle with the service brake.

1. Press the service brake.
2. Lock the service brake.

– see *“Locking the service brake” on page 5-6.*

► The oscillating-axle symbol appears in the indicating instrument for a few seconds, the oscillating axle is locked.

Do not switch into road-travel mode.

**Unlocking the oscillating axle with the service brake**

Release the service brake – see *“Locking the service brake” on page 5-6.*

**Locking the oscillating axle with the switch**

Lock the oscillating axle with the switch when performing special work (for example machine travel in operating mode).

1. Press switch **B** to position 1.

► The oscillating-axle symbol appears in the indicating instrument for a few seconds, the oscillating axle is locked.

Unlock the oscillating axle again after finishing the special work.

**Unlocking the oscillating axle with the switch**

Press switch **B** to position 2.

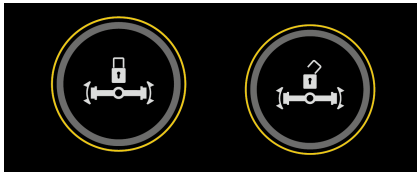


Fig. 181

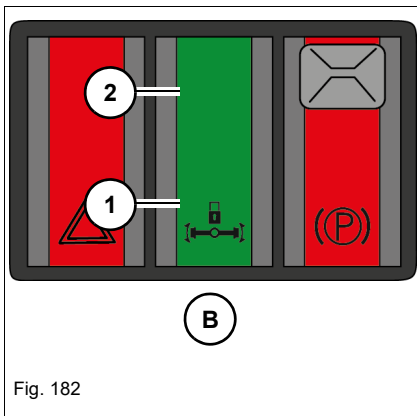


Fig. 182

**Information**

Unlock the oscillating axle before starting machine travel on public roads, otherwise the road-travel mode cannot be selected.

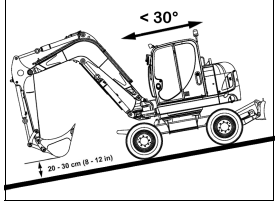
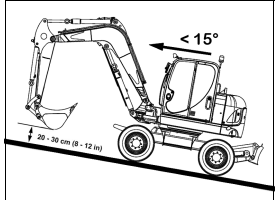
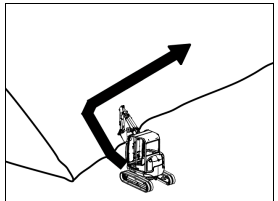
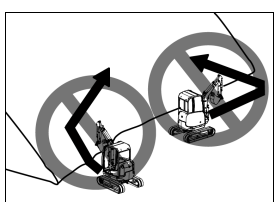
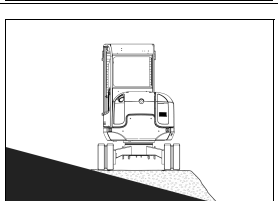
► Unlock the oscillating axle (road-travel mode)

**Operating temperature range**

Operate the machine only at ambient temperatures between  $-15^{\circ}\text{C}$  ( $5^{\circ}\text{F}$ ) and  $+45^{\circ}\text{C}$  ( $+113^{\circ}\text{F}$ ).



**Application limits of the vehicle**

Application	Description
	<p><b>Driving uphill and downhill (boom on the downhill side)</b> Allows up to a slope of 30°</p>
	<p><b>Driving uphill (boom on the uphill side)</b> Allows up to a slope of 15°</p>
	<p><b>Lateral slope travel</b> Allows up to a slope of 15°</p>
	<p><b>Diagonal drive</b> Prohibited</p>
	<p><b>Working with lateral inclinations</b> Only permitted on a horizontal, firm and level standing surface</p>

**WARNING****Crushing hazard due to tipping over of vehicle!**

A tipping vehicle can cause serious injury or death.

- ▶ Raise the boom 20 – 30 cm (8 – 12 in) off the ground and position it straight ahead at the center of the machine.
- ▶ In an emergency, lower the boom immediately to increase stability.
- ▶ Travel on slopes only on firm and level ground.
- ▶ Adapt the travel speed to the prevailing conditions.
- ▶ Pay attention to persons and obstacles.
- ▶ Adhere to the application limits of the vehicle.
- ▶ Perform uphill and downhill machine travel only in speed range 1.
- ▶ Never reverse downhill.
- ▶ Ensure that no parts of the body protrude outside the vehicle.
- ▶ Do not exceed the permissible payloads.
- ▶ Do not turn or swivel the upper carriage and the boom during downhill or uphill vehicle operation with a full attachment.
- ▶ Diagonal machine travel is prohibited.

Stones and the humidity in the upper layer of the ground can affect vehicle traction and stability.

The vehicle can slip sideways on gravel or loose, rocky soil. The stability of the vehicle can be reduced on rough terrain.

On soft ground, the vehicle sinks into it or the tracks dig into it. This increases the vehicle angle (maximum gradient angle and maximum lateral angle of inclination), and the vehicle can tip over.

If the engine dies as you perform uphill or downhill vehicle travel, immediately put the control levers to neutral position and restart the engine.

Observe under all circumstances during uphill or downhill travel:

- Keep the drive levers near the neutral position.
- Perform slow and smooth travel movements.
- Avoid sudden travel movements.
- Reduce the engine speed.

The vehicle can slip even on gentle slopes if it travels across grass, leaves, humid metal surfaces, frozen ground or ice.

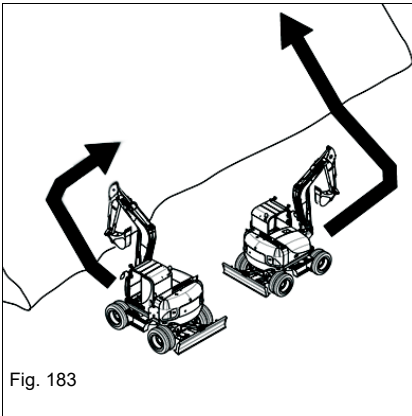


Fig. 183

**Preparations for performing vehicle travel on slopes**  
Always perform uphill or downhill vehicle travel in a straight line.  
If the position changes, do not exceed the application limits.

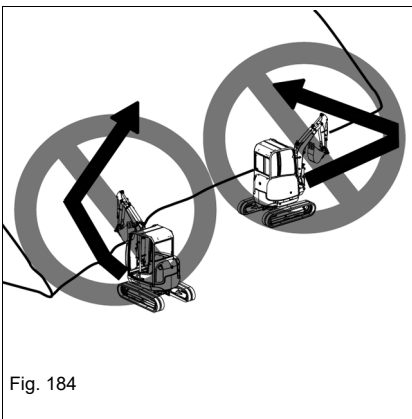


Fig. 184

Change position on level ground and then retract straight-ahead onto the slope.

## Machine travel on slopes

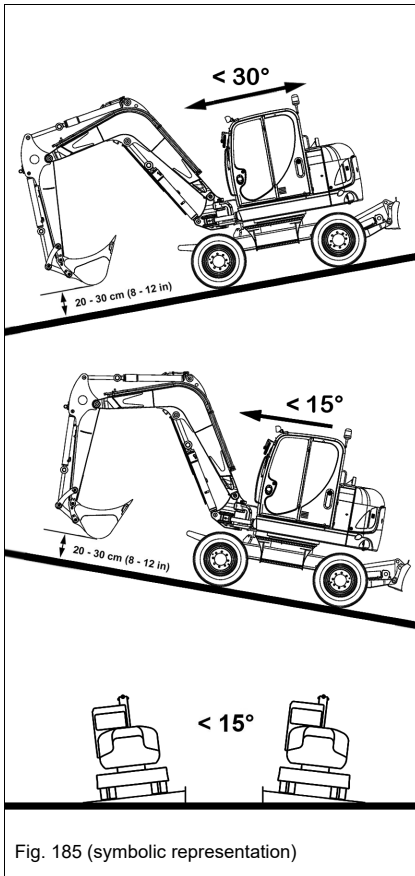


Fig. 185 (symbolic representation)

### Uphill and downhill travel (boom on downhill side)

- Raise the boom 20-30 cm (8-12 in) off the ground and align it at the center of the machine.
- Do not exceed the maximum angle of inclination of  $30^\circ$ .

### Uphill travel (boom on uphill side)

- Raise the boom 20-30 cm (8-12 in) off the ground and align it at the center of the machine.
- Do not exceed the maximum angle of inclination of  $15^\circ$ .

### Lateral slope travel

- Raise the boom 20-30 cm (8-12 in) off the ground and align it at the center of the machine.
- Do not perform machine travel on slopes with a lateral angle of inclination over  $15^\circ$ .

## Working with lateral inclination

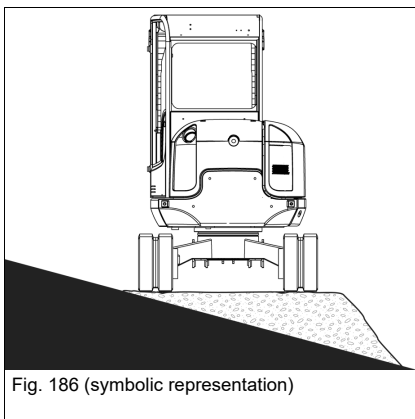


Fig. 186 (symbolic representation)

On lateral inclination, pile up material to create a horizontal, firm and level standing surface.



## **Parking the machine**



### **WARNING**

**Crushing hazard due to vehicle rolling away under its own weight after parking it!**

Serious injury or death can be caused by not securing the vehicle.

- ▶ Lower the boom and the stabilizer blade to the ground.
  - ▶ Secure the machine accordingly (for example with chocks).
- 



### **CAUTION**

**Crushing hazard when using the wheel chocks!**

Hitching the wheel chocks onto the bracket can cause injury.

- ▶ Hold the wheel chocks only with the handholds provided for this.
-

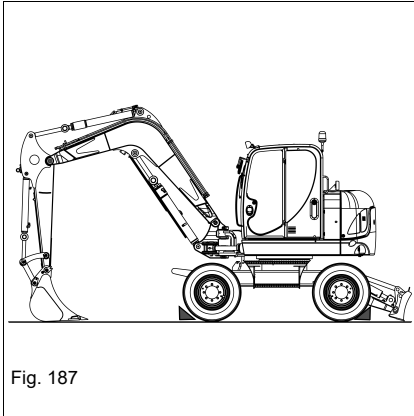


Fig. 187

1. Park the vehicle on firm, level, and horizontal ground.
2. Position the boom straight ahead at the center of the vehicle.
3. Lower the boom and the stabilizer blade to the ground.
4. Stop the engine.
5. Apply the parking brake.
6. Lock the service brake.
7. Operate the control lever repeatedly to release the pressure in the hydraulic system.
8. Remove the starting key and carry it with you.
9. Raise the control lever base.
10. Close the windows and doors.
11. Close and lock all covers and doors.
12. Secure the vehicle with wheel chocks (see [Fig. 187](#)).



### Information

In order to prevent the formation of condensation water, fill up the fuel tank nearly completely at the end of each working day.

### Parking the vehicle on slopes

If parking the vehicle on a slope cannot be avoided, observe the following in addition:

- Position the boom on the downhill side of the vehicle and firmly press the attachment into the ground.
- If the vehicle is equipped with the **triple articulation boom** option, line up the boom at an angle of approx. 120°.
- Place stabilizer blade on the downhill side.
- Press the stabilizer blade against the ground.

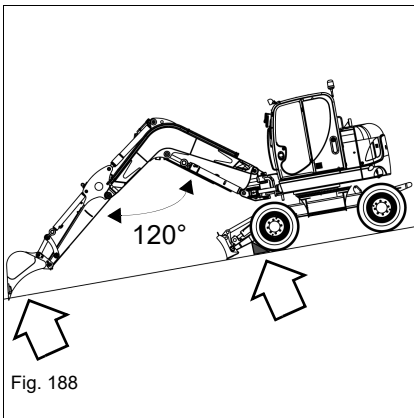


Fig. 188

### Wheel chocks

The wheel chocks are located on the left and right sides of the travel gear.

## 5.5 Differential lock

Not available.

## 5.6 Lights/signaling system

### **WARNING**

**Motorists can be blinded by bright lights on the job site!**

Working lights can blind motorists. This can cause serious injury or death.

- ▶ Stop vehicle operation if motorists are blinded.
- ▶ Take up operation again only when sufficient illumination of the working area is ensured without blinding motorists.

## Boom light

The push button is located on the right keypad.

Boom light	Push button	Indication
On		
Off		

## Roof and chassis headlights

The machine is equipped with the following lights:

- Chassis lights (left, right, front/standard)
- Roof lights (two at the front, one at the rear/option)

Optionally the lights can be equipped with energy-saving LED lamps.

The push button is located on the right keypad.

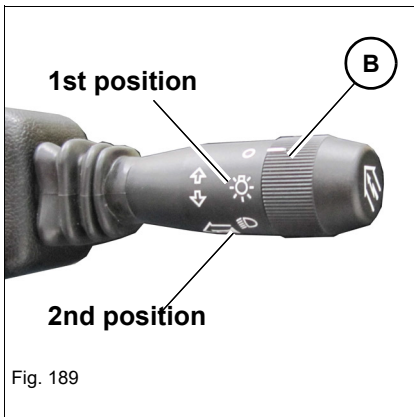
Roof/chassis lights	Push button	Indication
Roof lights ON		
Roof lights ON Chassis lights ON		
Chassis lights ON		
Roof lights off Chassis lights off		



### Information

Switch on the working lights in conditions of poor visibility. If illumination still is not sufficient, use external lights. If this is yet not enough to illuminate the job site sufficiently, stop vehicle operation and only start it again when sufficient illumination can be ensured.

**Light system**



Switch on the light system with ring **B** on public roads.

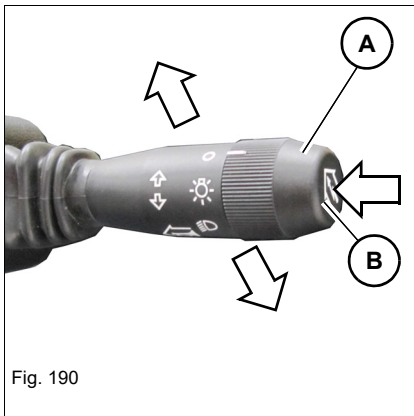
**i Information**

The clearance lights and low beam also work when the starter is disengaged.

► Switch off the lights before parking the machine.

Light system	Operation
Clearance lights switched ON	Turn ring <b>B</b> to the first position
Low beam switched ON	Turn ring <b>B</b> to the second position
Light OFF	Turn ring <b>B</b> to the front

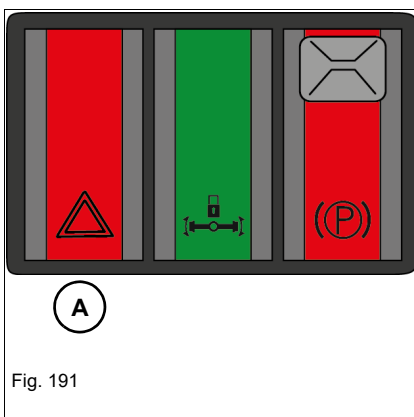
**Steering-column lever**



Operate the horn, turn indicators and high beam with steering-column lever **A**.

Steering-column lever	Operation
Turn indicators on the right flash	Pull steering column lever <b>A</b> down
Turn indicators on the left flash	Push steering-column lever <b>A</b> forward
Headlight flasher	Pull steering-column lever <b>A</b> upward and release it
High beam (ON)	Pull steering column lever <b>A</b> down
Actuate the horn	Press touch button <b>B</b>

**Hazard warning system**



Switch on the hazard warning system with switch **A** on the steering wheel.

**i Information**

Switch on the hazard warning system:

- In case of a breakdown.
- if part or the whole of the machine protrudes into a road during work.

### Interior lighting

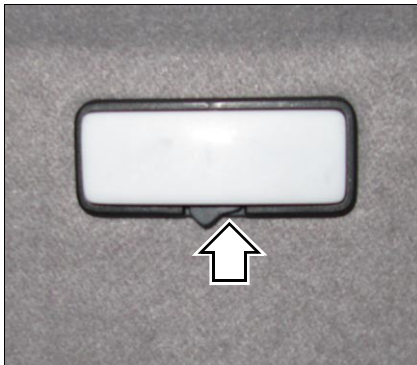


Fig. 192

The mechanical switch above the left B-pillar must be in the position on the right so that the interior light can be switched on and off with the help of the switch panel.

The push button is located on the right keypad.

Interior light	Push button	Indication
On		
Off		

### Rotating beacon (option)

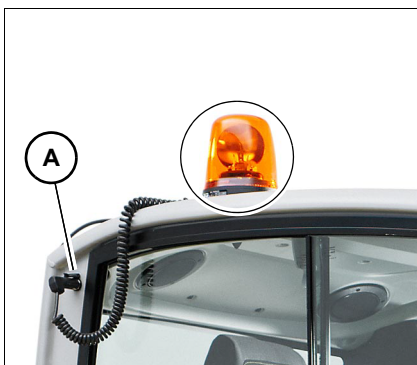


Fig. 193

The rotating beacon has a magnetic base and is attached either to the cabin roof or to the ROPS screen. The electric power supply has a 12-volt connection **A**.

The push button for the rotating beacon is located on the right keypad.

Rotating beacon	Push button	Indication
On		
Off		

**i** **Information**

Observe the national and regional regulations.

**Traveling signal (option)**

The travel signal sounds as soon as the accelerator pedal is pressed.

---

 **WARNING****Accident hazard during forward/backward vehicle operation!**






Serious crushing hazard causing death or serious injury.

- ▶ Do not allow anyone to stay in the danger zone.
  - ▶ Do not rely on the travel signal under any circumstances.
  - ▶ If the travel signal does not sound, stop vehicle operation immediately and contact a Wacker Neuson service center.
  - ▶ Follow the relevant national and regional regulations.
- 

<b>Mode</b>	<b>Travel signal</b>
Forward operating mode	Yes
Reverse operating mode	Yes
Forward street mode	No
Reverse street mode	Yes

## 5.7 Wiper/wash system

The touch buttons are located on the right keypad.

Wiper/wash system	Push button
Windshield wiper on	
Intermittent windshield wiper	
Windshield wiper off	
Spray function on	
Spray function off	

### **NOTICE**

Damage to pump if the reservoir is empty.

- ▶ Do not actuate the washer system if the reservoir is empty.
- ▶ Check the level in the reservoir and add a cleaning solution (glass cleaner) if necessary.

### **NOTICE**

Damage to wiper if the front window is raised.

- ▶ Do not actuate the wipers if the front window is raised.

## 5.8 Heating, ventilation and air conditioning system

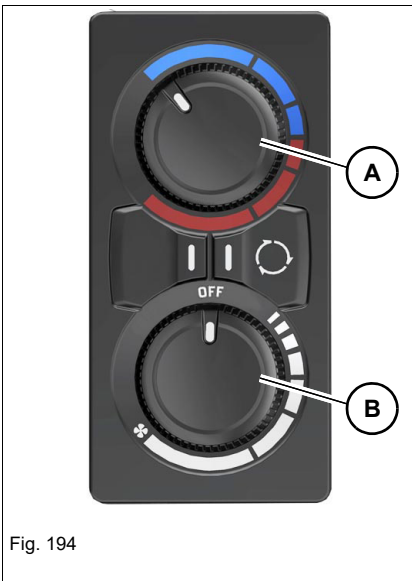
### CAUTION

**Damage to health due to incorrect operation of air conditioning system.**

Can cause health hazards.

- ▶ Do not direct the air vents directly at the face when the air conditioning system is switched on.

### Operation







The regulators and push buttons are located below the multi-functional display.

Set the required temperature (regulator **A**) and ventilation (regulator **B**).

### Recirculated air mode

The recirculated-air mode prevents outside air pollutants from entering the cabin.

Recirculated air mode	Push button	Indication
On		
Off (fresh-air mode)		

### Information

In recirculated-air mode the windows and the door must be closed. If the recirculated-air mode is used too long, the windows mist up. Switch to fresh air mode as soon as possible.



Fig. 195

### Air conditioning

The air conditioning system cools and dehumidifies the air inside the cabin.

Air conditioning	Touch button <sup>1</sup>	Indication
On		
Off		

1. The keyboard symbol flashes if the set temperature is lower than the interior temperature.

### Automatic mode (AUTO)

The automatic mode automatically controls the temperature and fan to ensure a constant temperature inside the cabin.

In the **OFF** position the entire system including the fan and heating is switched off.



### Information

Cool down the inside of the cabin quickly:

1. Open the windows and the door.
2. Set the fan to maximum speed so that the hot air can escape.
3. Close the windows and the door.
4. Switch on the air conditioning system and the recirculated-air mode.
5. Change over to fresh-air operation after reaching a comfortable temperature inside the cabin.































### Information

Let the air conditioning system run a few minutes several times a month to avoid damage to the air-conditioning compressor.

## 5.9 Operating hydraulics

### Basic control lever functions (ISO and SAE controls)

Control mode	Required function	ISO controls		SAE controls	
		Joysticks <sup>1</sup>		Control lever <sup>1</sup>	
		Left	Right	Left	Right
					
	Rotating the upper carriage to the left		--		--
	Rotating the upper carriage to the right		--		--
	Extend stick		--	--	
	Retract the stick		--	--	
	Lower the boom	--			--
	Raise the boom	--			--
	Tilt in the bucket	--		--	
	Tilt out the bucket	--		--	

1. The control levers shown are symbolic representations.

## ISO/SAE controls (option)

The standard equipment of the vehicle includes ISO controls. SAE controls are available as an option. This results in a different control lever operation.





### **WARNING**

#### **Accident hazard due to modified control mode!**

Modified controls can cause incorrect operation, and serious injury or death.

► Before starting work, check the selected control type.

The push button to change the control mode is located on the switch panel on the right.

Function	Push button	Pop-up window
ISO controls		
SAE controls		

#### **Switching from ISO to SAE controls and vice versa:**

Switching is only possible when the engine is running.

1. Raise the control lever base on the left
2. Press and hold the ISO/SAE button until the corresponding on-screen display appears.

**Rotating the upper carriage**

**⚠ WARNING**

**Crushing hazard due to rotating range of vehicle!**

Persons in the rotation range of the vehicle can be seriously injured or killed.

- ▶ Do not allow anyone to stay in the danger zone.

**NOTICE**

Possible damage to vehicle when working in the immediate vicinity of walls, parts of buildings or other obstacles.

- ▶ Ensure that there are no obstacles in the danger zone.

**i Information**

As long as the hydraulic fluid has not reached its operating temperature, the upper carriage can continue moving after releasing the control lever. Operate the control lever carefully in a cold operating state.

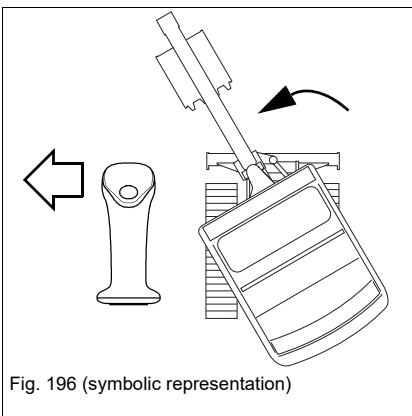


Fig. 196 (symbolic representation)

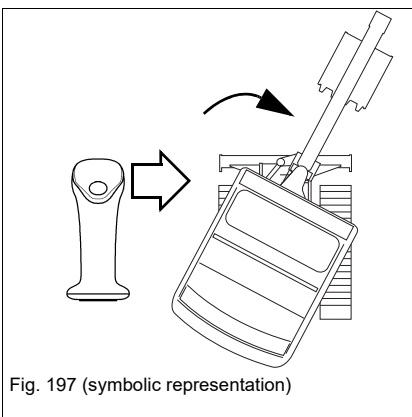


Fig. 197 (symbolic representation)

Rotating the upper carriage	Position
To the left	Push the control lever on the left to the left
To the right	Push the control lever on the left to the right

## Swivel unit brake

### Automatic swivel unit brake

When the upper carriage is rotated, the swivel unit brake is enabled with a time delay to hold the upper carriage.

The swivel unit brake is disabled again if the upper carriage is rotated again.

### Hydraulic swivel unit brake

Normal braking: release the control lever.

Maximum braking: press the control lever in the opposite direction until the upper carriage is at a standstill.

## Functional check of swivel unit brake

Perform the functional check on a warm vehicle after work once a day.

If the vehicle is put into operation again after a standstill of more than two weeks, perform a functional check once **before starting work**.

1. Park the vehicle on firm, level, and horizontal ground.
2. Raise the vehicle with the stabilizer blade as far as it will go.

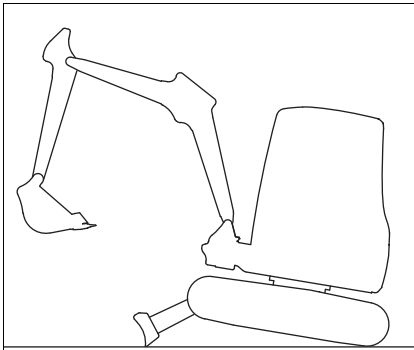


Fig. 198 (symbolic representation)

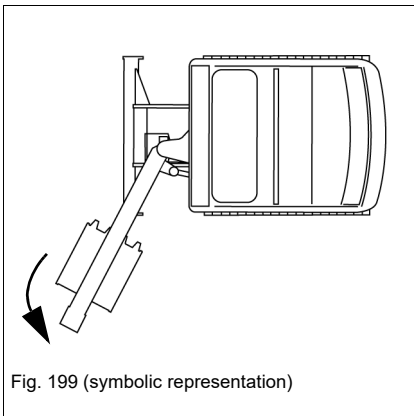
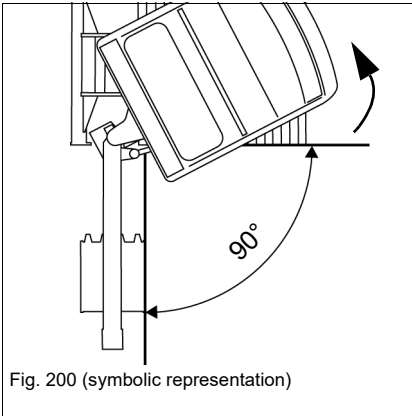
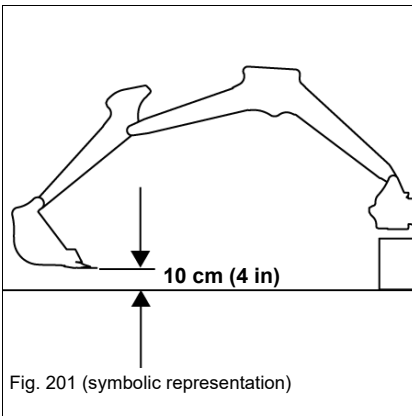


Fig. 199 (symbolic representation)

3. Swivel the boom to the left as far as it will go.



4. Turn the upper carriage so that the boom is 90° to the travel gear.

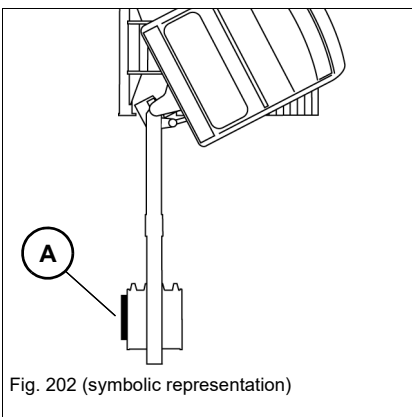


5. Position the boom as shown in [Fig. 201](#).

6. Stop the engine, remove the starting key and carry it with you.

7. Raise the control lever base.

8. Wait one minute.



9. Put a measuring rod **A** against the attachment.

10. Wait one minute.

➤ If the attachment does not move from the measuring rod:

➤ Machine is ready for operation.

➤ If the attachment moves from the measuring rod:

➤ Stop operation immediately.

➤ Contact a Wacker Neuson service center and have the malfunction rectified.



---

### Stabilizer legs/stabilizer blade

---

 **WARNING**

**Crushing hazard due to unintentional actuation!**

Unintentional actuation can cause serious injury or death.

- ▶ Raise the control lever base.
  - ▶ Lower the stabilizer blade to the ground after the work shift.
  - ▶ Do not allow anyone to stay in the danger zone.
- 

**NOTICE**

Damage to property during machine travel with lowered stabilizer legs.

- ▶ Raise the stabilizer legs before starting machine travel.
- 

**NOTICE**

Lowering the stabilizer blade too deeply into the ground can create increased resistance.

- ▶ Slightly raise the stabilizer blade. The clearance between the stabilizer blade and the ground should be about 1 cm (0.4 in).
  - ▶ Check the stabilizer-blade position before performing vehicle travel.
- 



**Information**

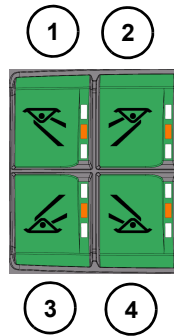
In order to achieve the best possible stability, lower the stabilizer blade/stabilizer legs.

---

The stabilizer blade or legs are used as a parking brake. Press the stabilizer blade/legs against the ground.

**Control elements:**

- Left switch panel
- Stabilizer-blade lever



Stabilizer legs <sup>1</sup>	Touch button <sup>2</sup>	Stabilizer blade lever position
Raise at the front left	1	6
Lower at the front left	1	5
Raise at the rear left	3	6
Lower at the rear left	3	5
Raise at the front and rear left	1/3	6
Lower at the front and rear left	1/3	5
Raise at the front right	2	6
Lower at the front right	2	5
Raise at the rear right	4	6
Lower a the rear right	4	5
Raise at the front and rear right	2/4	6
Lower at the front and rear right	2/4	5
Raise all	1/2/3/4	6
Lower all	1/2/3/4	5

1. The LED light of the corresponding push button must be illuminated.
2. If only a stabilizer blade is installed, it is only controlled by means of the stabilizer blade lever.

**i Information**

If stabilizer legs are installed instead of a stabilizer blade, only one button has to be pressed. The button next to it is automatically actuated.

**i Information**

At engine start all existing stabilizer blades and legs are activated. When the last button with an illuminated LED light is pressed, all LEDs illuminate again.



### Hammer operation

---

#### **WARNING**

##### **Danger of piercing/penetration by objects from the front!**

Work involving risk of piercing/penetrating by objects from the front can cause accidents with serious injury or death.

- ▶ During operation, all persons must stay clear of the job site of the vehicle.
  - ▶ Do not position the vehicle under the workplace during demolition, since debris could fall onto the vehicle.
  - ▶ Observe the mandatory limits of the work area.
  - ▶ The front window has to be closed.
- 

#### **WARNING**

##### **Accident hazard due to tipping over of vehicle!**

A tipping vehicle can cause serious injury or death.

- ▶ During operation, all persons must stay clear of the job site of the vehicle.
  - ▶ Do not perform any demolition work under the machine. This could cause the machine to tip over.
  - ▶ The vehicle can lose its balance and tip over if a hammer or other heavy attachment is used.
  - ▶ Never turn, lower or set down the attachment abruptly.
  - ▶ Do not extend or retract the boom abruptly.
  - ▶ Do not use the impact force of the attachment to perform demolition work. Broken or falling pieces can cause serious injury.
  - ▶ Use a hammer only at vehicle standstill.
- 

#### **Information**

In combination with Powertilt, use only the smallest possible released hydraulic breaker.

---

---

**Working with a hydraulic hammer**


---

**NOTICE**

In order to avoid damage to the vehicle or hydraulic hammer, observe the following points:

- ▶ Observe the Operator's Manual of the hydraulic hammer.
  - ▶ Do not hammer horizontally or upward.
  - ▶ Do not use the hammer to raise loads.
  - ▶ Do not hit the hammer against rocks, concrete, etc.
  - ▶ Do not hammer in the same spot uninterruptedly for more than 15 seconds.
  - ▶ Do not raise the vehicle with the boom.
  - ▶ Working with the cylinders or the boom fully extended is prohibited.
  - ▶ Do not swivel the Powertilt unit beyond 30° during hammer operation, otherwise the load on the boom increases enormously.
  - ▶ Stop vehicle operation immediately if a hydraulic hose moves back and forth in an unusual manner. The pressure accumulator could be malfunctioning. Contact a Wacker Neuson service center and have the malfunction rectified immediately.
  - ▶ Do not use the impact force of the attachment to perform demolition work. Broken or falling pieces can cause damage to the equipment.
- 

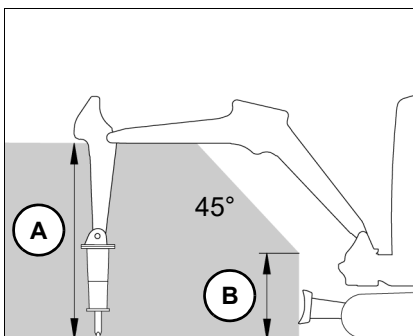


Fig. 203 (symbolic representation)

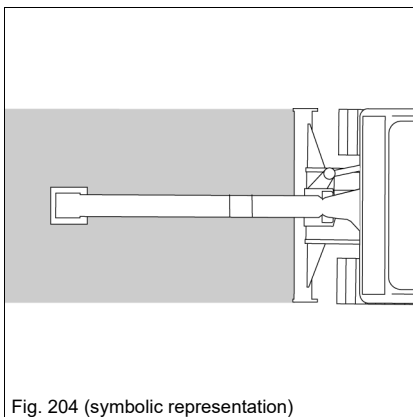


Fig. 204 (symbolic representation)

**Job site**

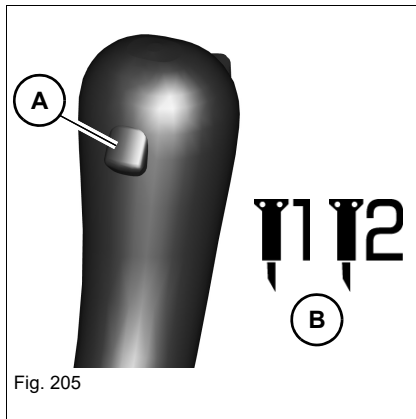
Work range height **A**: 225 cm (89 in), **B**: 50 cm (20 in)

Figures 203 and 204 refer to work with a Wacker Neuson hydraulic hammer.

Working with another tool can result in a different work area.

**NOTICE**

Set the maximum oil flow – see chapter “Adjusting the starting point and maximum required flow rate” on page 5-50.

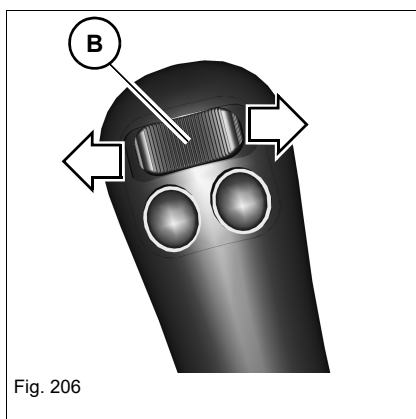


Hammer operation	Position
On	Press and hold touch button <b>A</b> on the joystick on the left
Off	Release push button <b>A</b>

**NOTICE**

Possible damage to the hydraulic hammer.

- ▶ Use the jog dial to select one of the hammer symbols **B** as an attachment in order to activate the reflux line.

**Auxiliary hydraulics – AUX I**

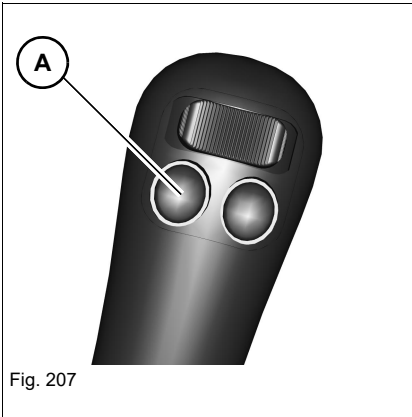
The auxiliary hydraulics system is operated with the right control lever. Adjust the required oil flow.

– see chapter “Adjusting the starting point and maximum required flow rate” on page 5-50

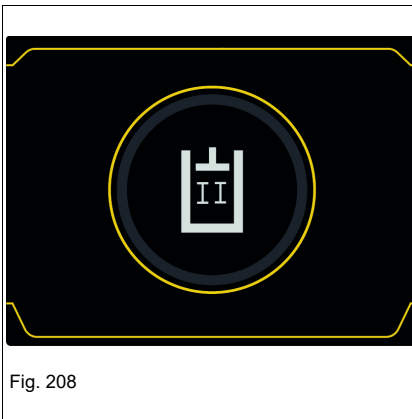
Oil flow	Position
To the line on the left	Press switch <b>B</b> to the left
To the line on the right	Press switch <b>B</b> to the right

**Additional control circuits**

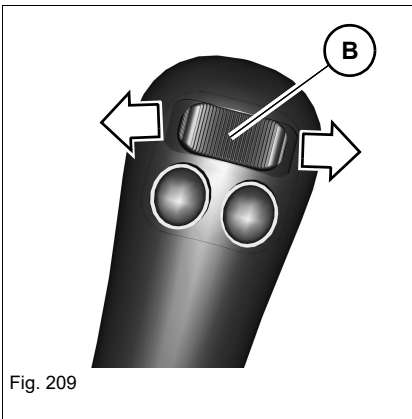
**AUX II (option)**



Toggle between **AUX II** and **AUX III** with touch button **A** on the left joystick.



If the **AUX II** function is selected, the symbol appears in the center of the display for a few seconds.



Adjust the required oil flow.

– see chapter “*Adjusting the starting point and maximum required flow rate*” on page 5-50

Oil flow	Position
To the line on the left	Press switch <b>B</b> to the left
To the line on the right	Press switch <b>B</b> to the right

AUX III (option)

**! WARNING**

**Crushing hazard due to rotating movements of the Powertilt unit!**

Rotating the Powertilt unit can cause serious injury or death.

► Do not allow anyone to stay in the danger zone.

**i Information**

The Powertilt unit may only be installed and removed by a Wacker Neuson service center!

For more information, see **Easy Lock/Powertilt with Easy Lock Operator's Manual**.

Toggle between **AUX III** and **AUX II** with touch button **A** on the left joystick.

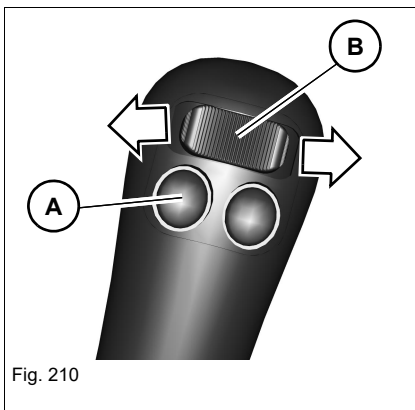


Fig. 210



Fig. 211

If the **AUX III** function is selected, the symbol appears in the center of the display for a few seconds.

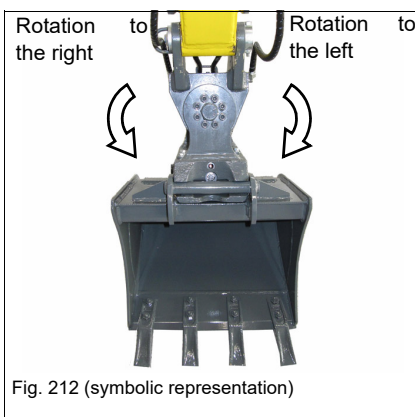


Fig. 212 (symbolic representation)

Adjust the required oil flow.

– see chapter “Adjusting the starting point and maximum required flow rate” on page 5-50

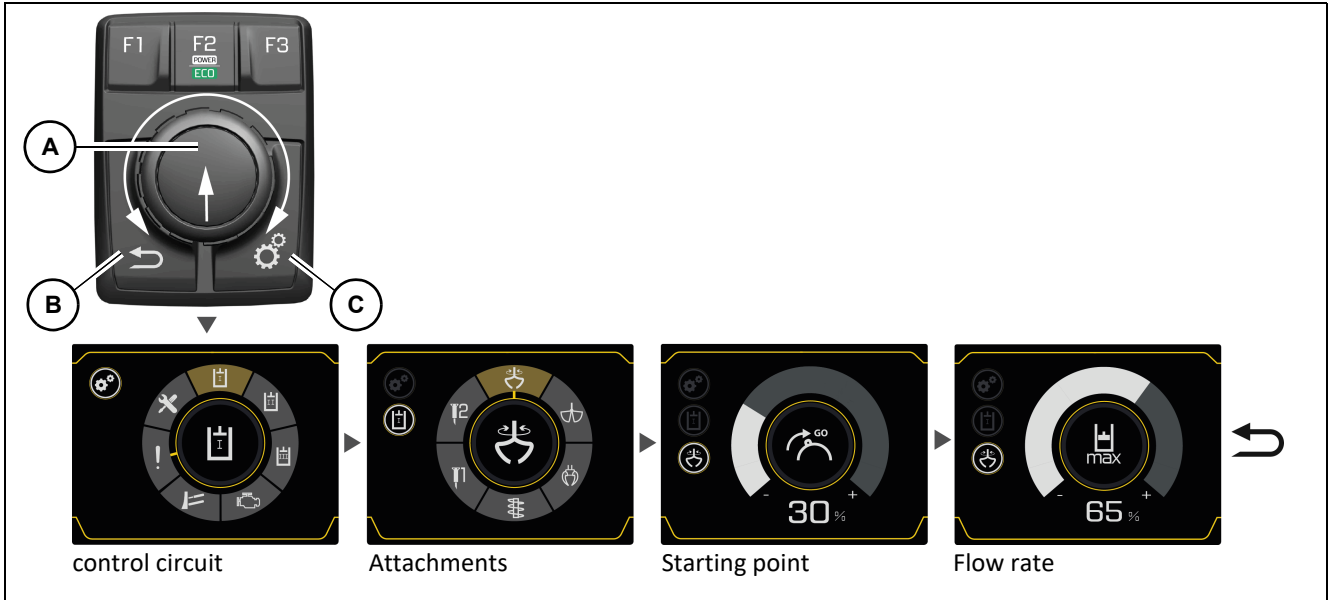
Function <sup>1</sup>	Operation
Rotation to the left	Press switch <b>B</b> to the left
Rotation to the right	Press switch <b>B</b> to the right

1. Depending on the system used or the valid norm, the rotation of direction may differ.

**Proportional controls**

The proportional controls allow to continuously adjust the oil flow for the attachment.

Additionally the required starting point for the oil flow can be adjusted with the switch.



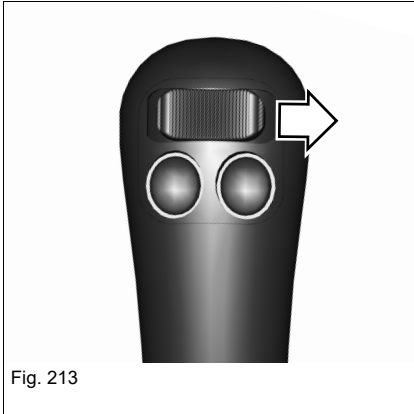
**i Information**

Example for AUX I. The operation for AUX II, AUX III and the dozer blade are identical.

**Performing the adjustments**

- Press push button **C** to call the settings.
- The settings are selected (turn) and confirmed (press) with adjustment button **A**.

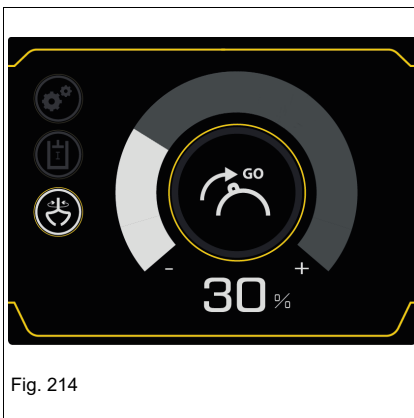
Push button **B** (return) takes you back to the previous menu level.



### Adjusting the starting point and maximum required flow rate

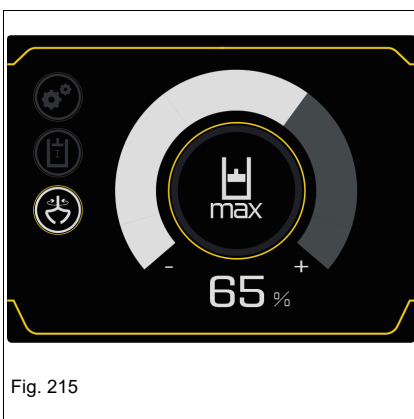
The starting point of the control lever switch and the maximum required flow rate can be configured according to the attachment and the work to be performed.

1. Press the switch to the position at which the attachment is supposed to start moving.



2. Hold the switch and turn adjustment button **A** at the same time to select the starting point.

3. Press adjustment button **A** to confirm.

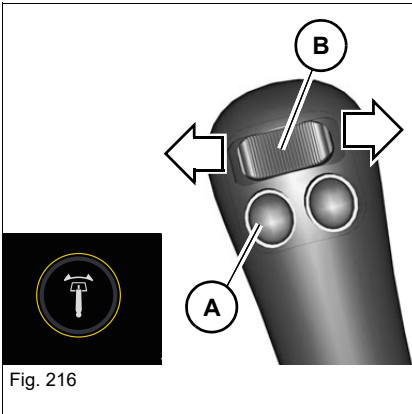


4. Press the switch as far as it will go and hold it there.

5. Turn adjustment button **A** to select the maximum required flow rate.

6. Press adjustment button **A** to confirm.

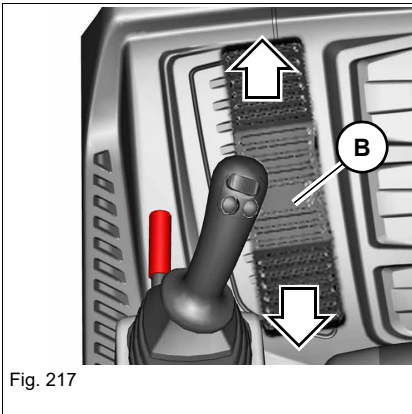
**Swiveling the boom**



Select the **boom swiveling** function with push button **A** on the control lever on the right. The symbol on the left appears in the multifunctional display

Boom	Position
Swivel to the left	Press switch <b>B</b> to the left
Swivel to the right	Press switch <b>B</b> to the right

**Operating the triple articulation boom (option)**



Triple articulation boom	Position
Extend	Push pedal <b>B</b> forward
Retract	Push pedal <b>B</b> backward

### Lifting gear applications

Lifting gear applications are procedures involving raising, transporting and lowering loads with the help of lifting and fastening gear.

---

#### **DANGER**

##### **Crushing hazard due to tipping over of vehicle!**

The vehicle causes serious injury or death when it tips over.

- ▶ Do not exceed the weights indicated in the load diagrams.
  - ▶ Subtract the weight of the attachment from the weight specified in the relevant load diagram.
  - ▶ Use the vehicle for lifting gear applications only if the mandatory lifting gear and safety equipment is installed, functional and enabled.
  - ▶ The subgrade must be horizontal, even, and have a high load-bearing capacity.
- 

#### **WARNING**

##### **Risk of vehicle tipping over due to failure to pay attention to the safe load indicator!**

Serious injury or death can be caused by a vehicle tipping over.

- ▶ Reduce the load until both the buzzer and the indicator light on the display element go out.
  - ▶ Observe the load diagrams.
- 

#### **WARNING**

##### **Accident hazard due to switched-off or malfunctioning safe load indicator!**

Serious injury or death can be caused by a vehicle tipping over.

- ▶ Switch on the safe load indicator during lifting gear applications.
  - ▶ Operate the vehicle only with an intact safe load indicator.
- 

#### **NOTICE**

Machine damage due to a vehicle tipping over if the weight in the load diagram is exceeded.

- ▶ Do not exceed the weights indicated in the load diagrams.
-




**Safe load indicator**

The safe load indicator alerts the operator visually and acoustically if the load on the boom is too high.

The standard equipment of the machine includes a safe load indicator Advanced.

Position	Safety equipment
Boom	Hose burst valve
Shovel arm	Hose burst valve
Stabilizer blade	Counterbalance valve

The push button for activating and deactivating the safe load indicator is located on the switch panel.

Safe load indicator	Push button	Indication
On		
Off		No symbol

**Functional check of safe load indicator**

Always perform a functional check of the safe load indicator before performing lifting gear applications.

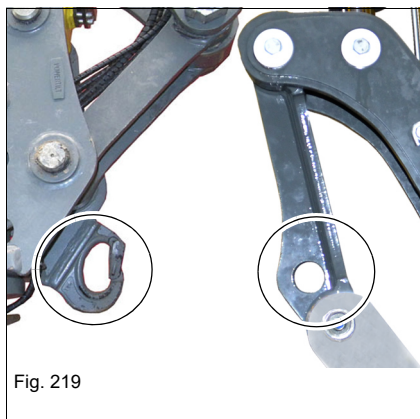
1. Start the vehicle.
2. Perform vehicle travel on open terrain.
3. Secure the danger zone.
4. Stop the vehicle.
5. Switch on the safe load indicator.
6. Raise the boom as far as it will go and hold the control lever in this position.



Warning devices	Result
The buzzer sounds and symbol <b>A</b> is displayed	The vehicle may be used for lifting gear applications.
Buzzer does not sound or symbol <b>A</b> is not displayed	The vehicle may not be used for lifting gear applications. Contact a Wacker Neuson service center.

**Perform a functional check of the control lever base.**

– see chapter “Functional check of joystick base” on page 4-51



Only the following lifting gear may be used for lifting gear applications:

- Powertilt/quickhitch with load hook
- Joint rod with lifting eye



When symbol **A** is displayed and the buzzer sounds:

- Reduce the load until the buzzer goes out and the symbol disappears. Suitable equipment for fastening and securing loads must be available.

## Lehnhoff mechanical quickhitch system (optional)

- The quick coupler system and the attachment support must be undamaged and clean.
- Store the Operator's Manual of the mechanical quick coupler system together with the Operator's Manual of the vehicle.
- The described operation does not apply to the face shovel. Contact an authorized workshop for face shovel operation.

---

### **WARNING**

#### **Crushing hazard when picking up attachments!**

If an attachment is not locked correctly, it can come off and cause serious injury or death.

- ▶ Do not allow anyone to stay in the danger zone.
- ▶ During locking and unlocking procedures, make sure that hands and feet are not crushed.
- ▶ Only use undamaged attachments and quick coupler systems.
- ▶ Before starting any work and after every locking process, press the attachment to the ground and quickly move it back and forth over just over the ground a few times to check the secure locking.
- ▶ Only operate the vehicle with a safely locked attachment.

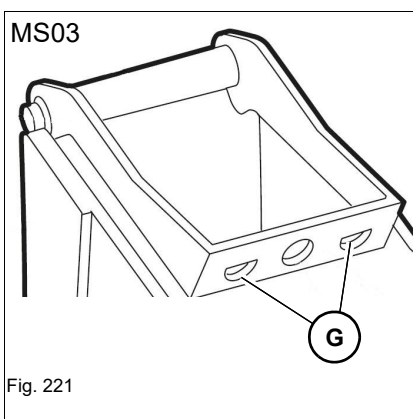
---

### **WARNING**

#### **Crushing hazard when attachments are removed!**

If an attachment is not removed correctly, it can tip over and cause serious injury or death.

- ▶ Do not allow anyone to stay in the danger zone.
- ▶ Lower the attachment to level and firm ground ensuring stability.



#### **Support**

EW65: Support for MS03

**G:** Openings for quick coupler system bolts

**Picking up an attachment**

1. Hook up the quick coupler system **A** in the attachment bolt **B**.
2. Slightly screw in the quick coupler system **A**, lift the shovel arm until the attachment is suspended about 30 cm (12 in) above the ground.
3. Extend the bucket cylinder so that the edge **C** of the attachment touches the quick coupler system.

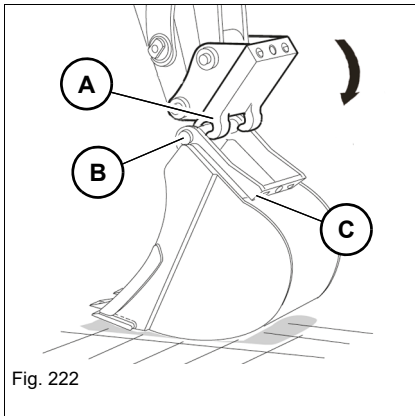


Fig. 222

4. Screw in the quick coupler system **A** until the attachment lies completely on the quick coupler system **A** due to its weight.
5. Shut off the engine and store the ignition switch key safely.

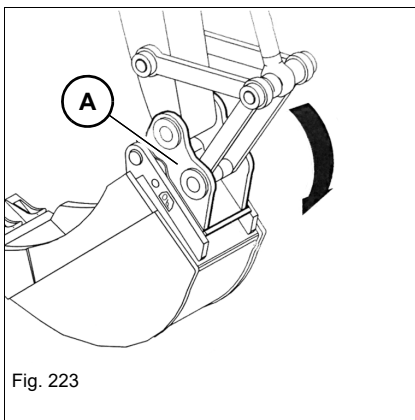


Fig. 223

6. Screw socket wrench **D** clockwise until the bolts **E** completely engage in the openings **G** of the quick coupler system **A**.
  - The quick coupler system is locked.
7. Remove the socket wrench and perform a visual inspection.
8. Start the engine.

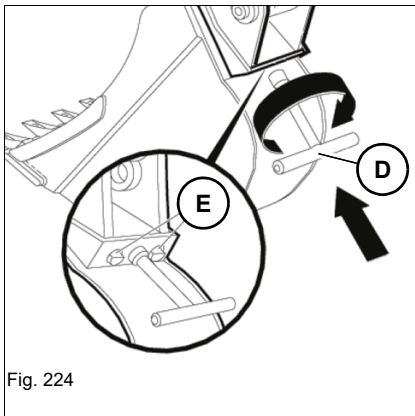


Fig. 224

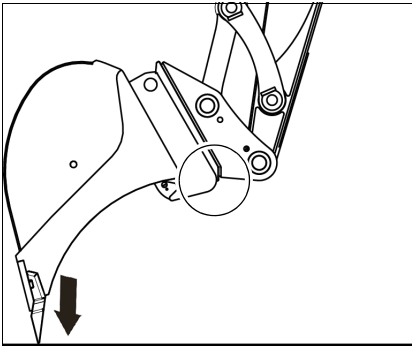


Fig. 225

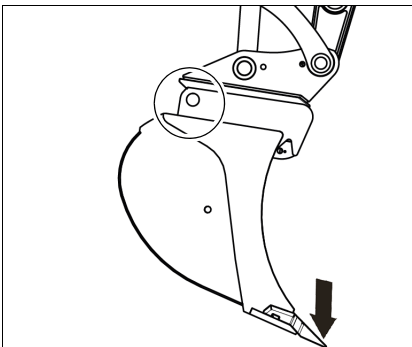


Fig. 226

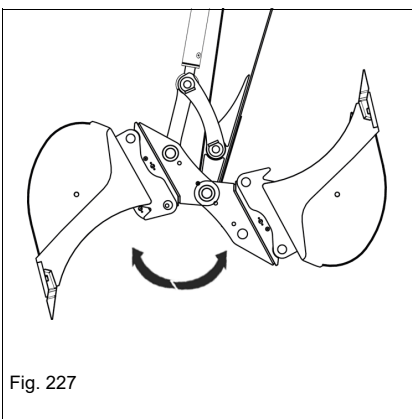


Fig. 227

9. Before starting any work and after every locking process, press the attachment to the ground and quickly move it back and forth over just over the ground a few times.
- ➔ The attachment may not detach from the quick coupler system in the process.

### Setting down an attachment

1. Screw in the attachment and position it at 5–10 cm (2–4 in) above the ground.
2. Shut off the engine and store the ignition switch key safely.

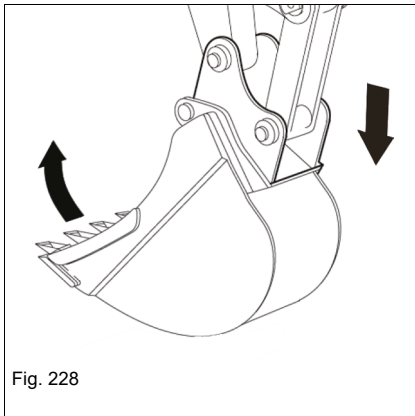


Fig. 228

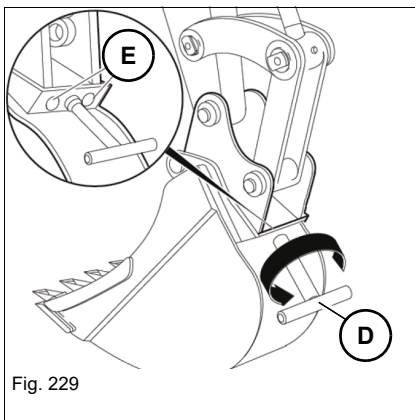


Fig. 229

3. Turn the socket wrench **D** counter-clockwise until the bolts **E** are completely retracted.
  - The quick coupler system is unlocked.
4. Remove the socket wrench.
5. Start the engine.
6. Lower the attachment to level and firm ground ensuring stability.

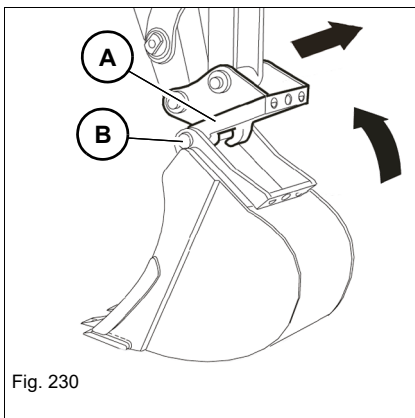


Fig. 230

7. Retract the bucket cylinder and quick coupler system **A** from the attachment bolt **B**.

## **Preparation for hydraulic quickhitch (option)**

The HSWS preparation is a hydraulic auxiliary control circuit attached to the vehicle boom that was designed, developed and released for the hydraulic quick coupler systems described in this operator's manual.

Wacker Neuson is not liable for injuries or damage if at least one of the following items is not complied with:

- Follow the operator's manual for the hydraulic quickhitch.
- Store the Operator's Manual of the hydraulic quickhitch together with the Operator's Manual of the vehicle.
- For non-released quickhitch systems, there may be differences in the operating functions or the operation of the vehicle. Observe the operator's manual of the quickhitch system or the attachment.

Nevertheless, should a non-released HSWS be used, the following points must also be observed:

- If required, modifications on the vehicle (for example additional adhesive labels) or the Operator's Manual of the vehicle (if operation is different) must be made.
- The intended purpose of the vehicle may be restricted.
- Assembling a hydraulic quick coupler system that does not fit with the vehicle or its interface (e.g. pressure settings) may void the declaration of conformity of the vehicle. Contact a Wacker Neuson service center.
- Assembling a hydraulic quick coupler system to a vehicle that does not fit with the vehicle or its interface (e.g. pressure settings) may void the declaration of conformity of the hydraulic quick coupler. Contact a Wacker Neuson service center.



---

### Hydraulic quickhitch system/Easy Lock (Option)

- Attend specific training before putting into operation. Training must be given by authorized technical personnel and must be understood by the operator.
- For safety reasons, the quickhitch must be operated with two control elements. This avoids opening the quickhitch unintentionally during work operation.
- The quick couplers and attachment receptacle must be clean before hitching.
- For more information, see **Easy Lock/Powerlift with Easy Lock Operator's Manual**.
- Store the **Easy Lock/Powerlift with Easy Lock operator's manual** together with the vehicle's operator's manual.



#### **WARNING**

##### **Crushing hazard when picking up attachments!**

If an attachment is not locked correctly, it can come off and cause serious injury or death.

- ▶ Do not allow anyone to stay in the danger zone.
- ▶ Only use undamaged attachments and quick coupler systems.
- ▶ Check pin **D** must be fully retracted. Otherwise repeat the lock cycle until check pin **D** is retracted.
- ▶ Before starting any work and after every locking process, press the attachment to the ground and quickly move it back and forth over just over the ground a few times to check the secure locking.
- ▶ Operate the vehicle only with a safely locked attachment.



#### **WARNING**

##### **Crushing hazard when attachments are removed!**

If an attachment is not removed correctly, it can tip over and cause serious injury or death.

- ▶ Do not allow anyone to stay in the danger zone.
  - ▶ Lower the attachment to level and firm ground ensuring stability.
-

**i** **Information**

If more than 10 seconds pass between the actuation of switch **B** and push button **C**, the symbols **Hydraulic quickhitch enabled** and **Hydraulic quickhitch disabled** are displayed alternately. The buzzer sounds in shorter intervals.

- ▶ Press switch **B** again and press push button **C** within 10 seconds.

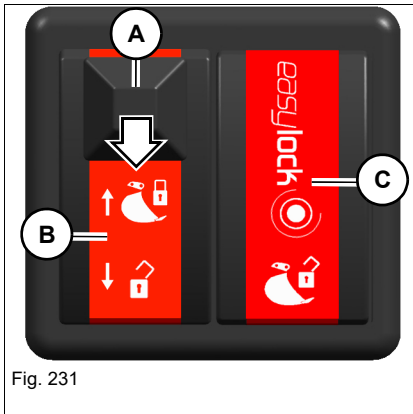


Fig. 231

**Picking up an attachment**

1. Pull lock **A** down.
2. Press switch **B** down.

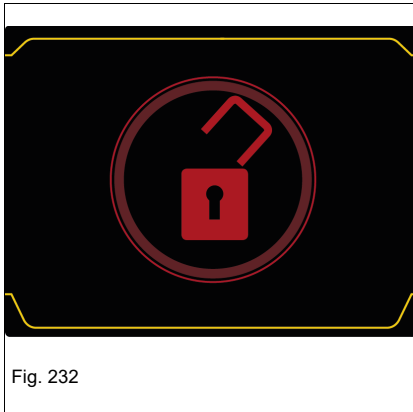


Fig. 232

- ▶ The symbol **Hydraulic quickhitch enabled** appears and the buzzer sounds.

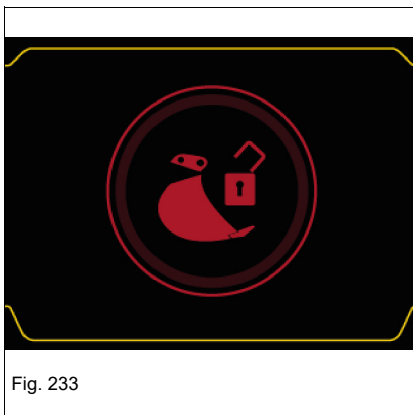


Fig. 233

3. Press touch button **C** within 10 seconds.
- ▶ The quickhitch opens.

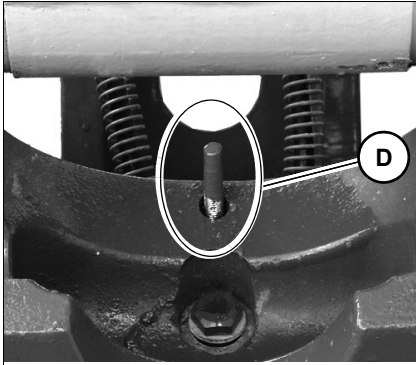


Fig. 234

➔ Check pin **D** must be fully extended.

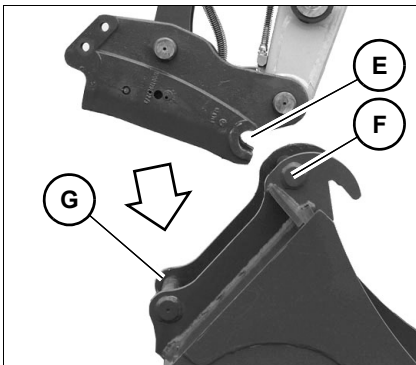


Fig. 235

4. Hook up the quick coupler system **E** in bolt **F** of the attachment receptacle.
5. Extend the bucket cylinder so that pin **G** of the attachment touches the quickhitch.
6. Check whether the attachment touches the quickhitch with the second pin **G**.
7. Move the attachment inward completely.

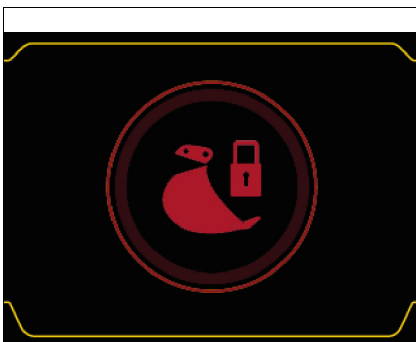


Fig. 236

8. Press switch **B** upward.
  - ➔ The quickhitch closes.
  - ➔ The symbol **Hydraulic quickhitch disabled** appears for a few seconds and the buzzer does not sound any more.

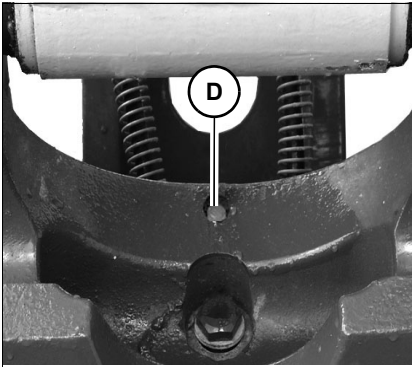


Fig. 237

9. Check pin **D** must be fully retracted.

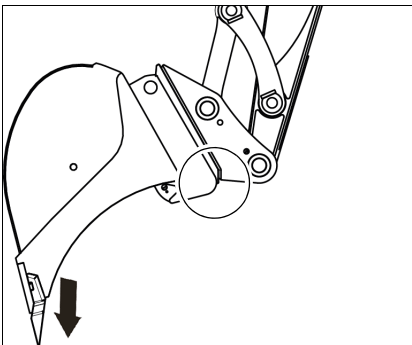


Fig. 238

10. Before starting any work and after every locking process, press the attachment to the ground and quickly move it back and forth over just over the ground a few times to check the secure locking.

➤ The attachment may not detach from the quick coupler system in the process.

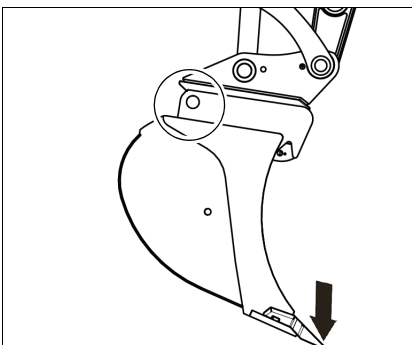


Fig. 239

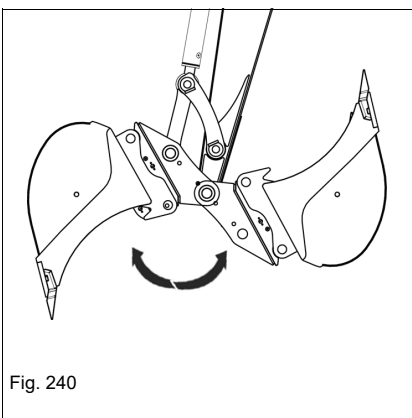


Fig. 240

### Manual HSWS bolt lock

Depending on national provisions, the HSWS must also be manually locked according to the hydraulic locking process.

The lock housing is located on the left of the quick coupler.

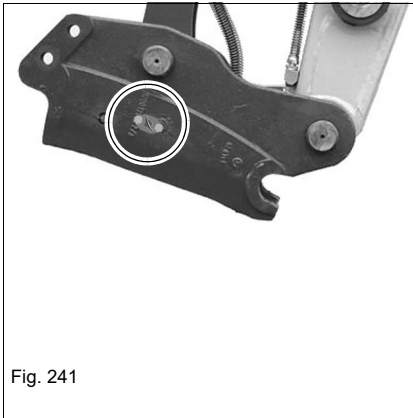


Fig. 241

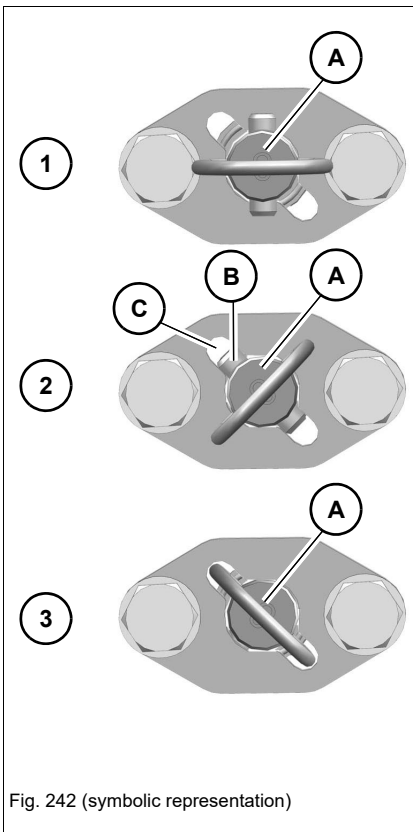


Fig. 242 (symbolic representation)

- Stop the engine and remove starting key.
- Raise the control lever base.
- Rotate bolt **A** so that the pin **B** fits in the recess **C** (2).
- Press in bolt **A** and turn until it is held in its position by spring (3).
  - ➔ The HSWS is also manually locked.

---

#### **i** Information

Comply with national provisions.

---



---

#### **i** Information

The bolt positions may deviate in their final position from the figures.

---

### Setting down an attachment

#### Manual HSWS bolt unlocking

Depending on national provisions, the HSWS must also be manually unlocked according to the hydraulic unlocking process.

The lock housing is located on the left of the quick coupler.



Fig. 243

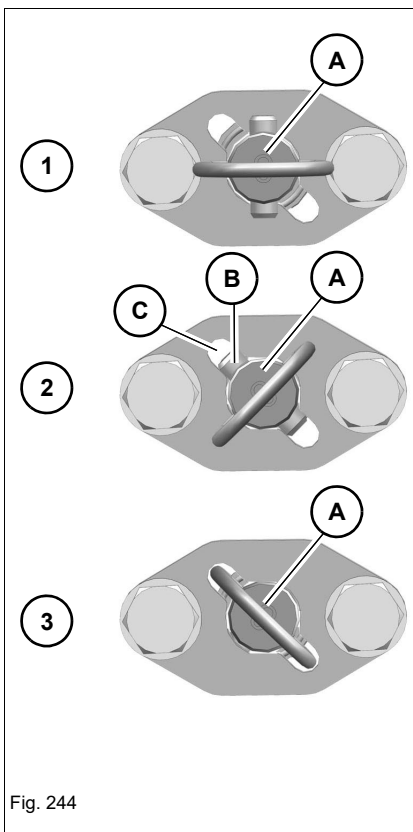


Fig. 244

- Stop the engine and remove starting key.
- Raise the control lever base.
- Rotate bolt **A** so that the pin **B** fits in the recess **C** (2).
- Pull out the bolt **A** (1).
  - ➔ The HSWS is manually unlocked.

---

#### **Information**

Comply with national provisions. The attachment is still hydraulically locked.

---

#### **Information**

The bolt positions may deviate in their final position from the figures.

---

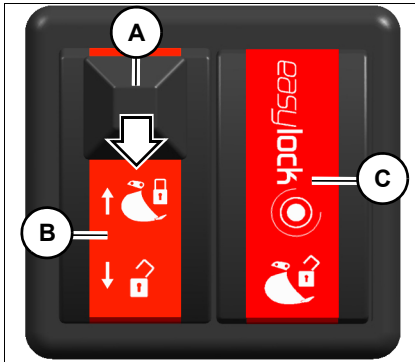


Fig. 245

1. Move the attachment inward completely and position it at 5–10 cm (2–4 in) above the ground.
2. Pull lock **A** down.
3. Press switch **B** down.



Fig. 246

➔ The symbol **Hydraulic quickhitch enabled** appears and the buzzer sounds.



Fig. 247

4. Press touch button **C** within 10 seconds.
- ➔ The quickhitch opens.

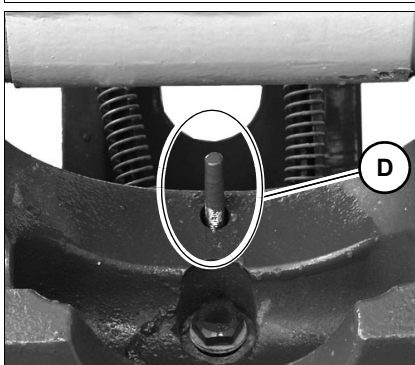


Fig. 248

➔ Check pin **D** must be fully extended.

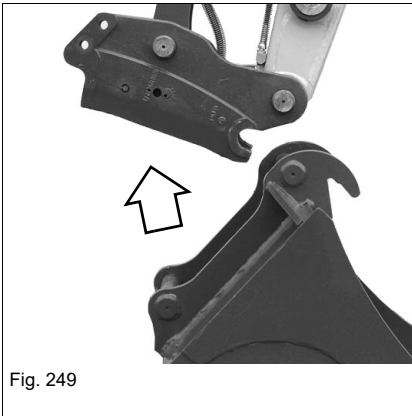


Fig. 249

5. Retract the bucket cylinder.
6. Set down the attachment.
7. Raise the boom.

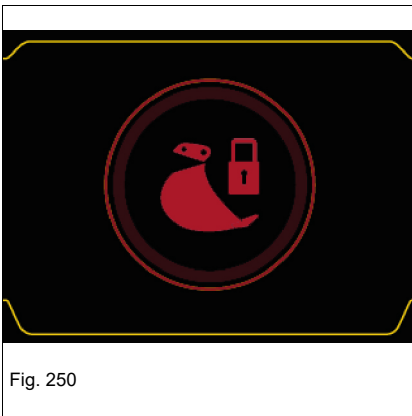


Fig. 250

8. Press switch **B** upward.
  - The quickhitch closes.
  - The symbol **Hydraulic quickhitch disabled** appears for a few seconds and the buzzer does not sound any more.

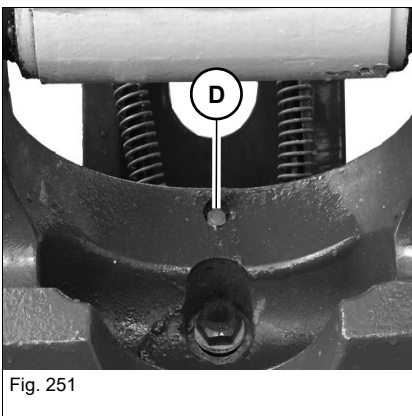


Fig. 251

9. Check pin **D** must be fully retracted.

## Changing attachments

### Information

Observe manual locking and unlocking.

- see chapter “Manual HSWS bolt lock” on page 5-64;
- see chapter “Manual HSWS bolt unlocking” on page 5-65

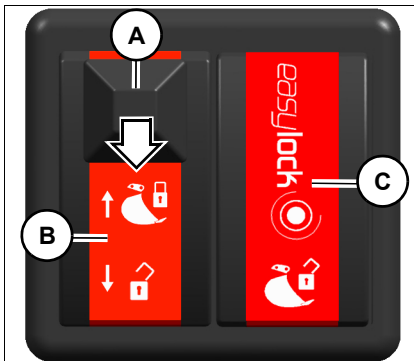


Fig. 252

1. Lower the attachment to about 5–10 cm (2–4 in) above the ground.
2. Pull lock **A** down.
3. Press switch **B** down.



Fig. 253

- ➔ The symbol **Hydraulic quickhitch enabled** appears and the buzzer sounds.



Fig. 254

4. Press touch button **C** within 10 seconds.
- ➔ The quickhitch opens.

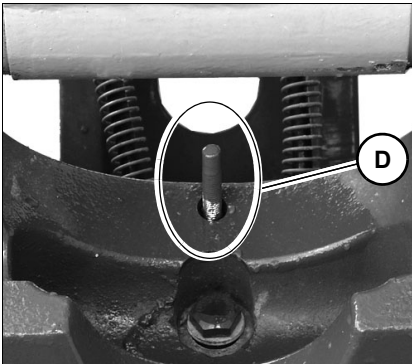


Fig. 255

➔ Check pin **D** must be fully extended.



Fig. 256

5. Retract the bucket cylinder.
6. Set down the attachment.
7. Raise the boom.

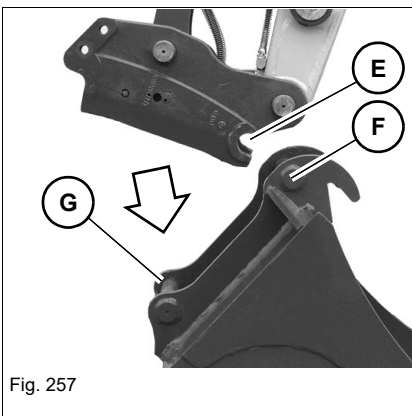


Fig. 257

8. Hook up the quick coupler system **E** in bolt **F** of the attachment receptacle.
9. Extend the bucket cylinder so that pin **G** of the attachment touches the quickhitch.
10. Check whether the attachment touches the quickhitch with the second pin **G**.

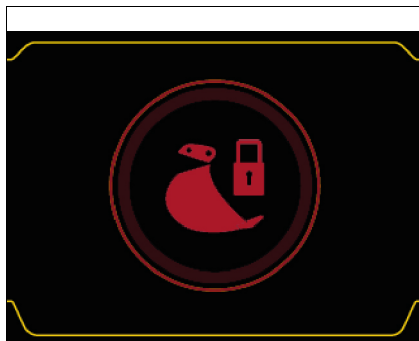


Fig. 258

11. Press switch **B** upward.

- ➔ The quickhitch closes.
- ➔ The symbol **Hydraulic quickhitch disabled** appears for a few seconds and the buzzer does not sound any more.

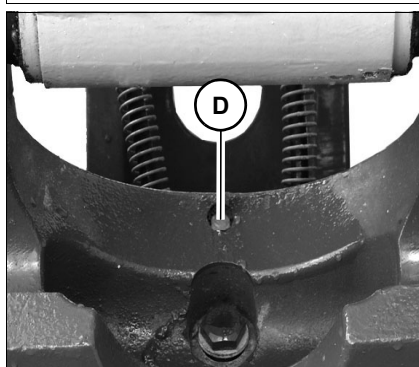
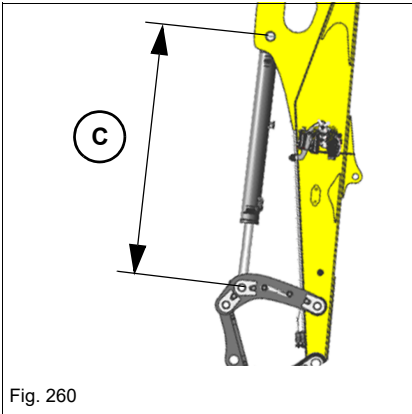


Fig. 259

12. Check pin **D** must be fully retracted.

**AUX V (option)**

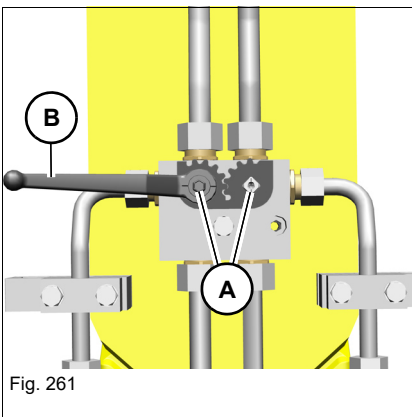


Before switching to the grab operation, the bucket ram must be positioned in such a way that the distance **C** lies between 1000 mm (39 in) and 1300 mm (51 in).

**NOTICE**

Possible damage to the boom due to an incorrectly positioned bucket cylinder.

The ball-type cock is located at the end of the boom.



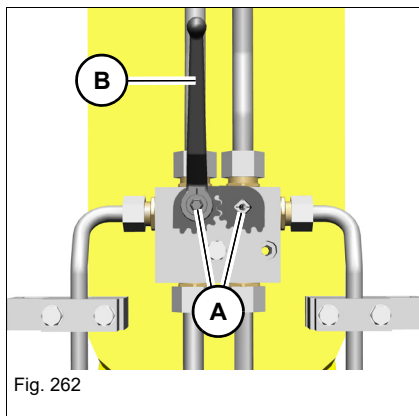
**Selecting:**

Set ball-type cock **A** to the required position with lever **B** on one side of the stick.

Gear wheel position	Operating
	<p>Bucket operation</p>
	<p>Grab operation</p>

**i** Information

Lever **B** must always be removed before operation.

**Connecting and disconnecting hydraulic couplings**

1. Park vehicle— *see chapter “Preparing lubrication” on page 7-9*
  2. Turn the starting key to position 1.
  3. Move the control lever or the pedal of the hydraulic circuit in all directions repeatedly.
  4. Remove the starting key and carry it with you.
- ➔ The couplings of the attachment can now be coupled and uncoupled.

## Hydraulic connections

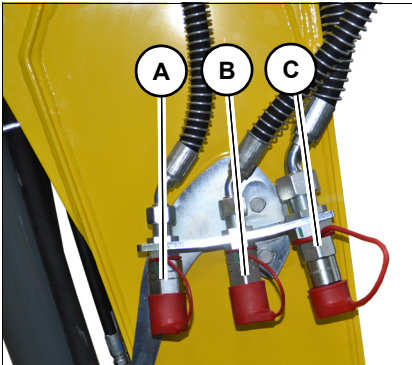


Fig. 263

Connection	Stick (left/right)
A	AUX V
B	AUX II
C	AUX I

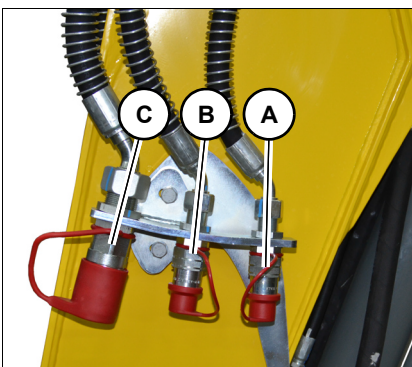


Fig. 264

### **i** Information

Follow the instructions in the Operator's Manual of the attachment manufacturer for connecting the hydraulics to the attachment.



## Load-retaining function

### **WARNING**

#### **Injury hazard due to fluid escaping under pressure!**

Hydraulic oil escaping under pressure can penetrate the skin and cause serious injury or death.

- ▶ Do not allow anyone to stay in the danger zone.
- ▶ If a hose bursts, move the control elements to neutral position so that as little hydraulic oil as possible escapes.

### **WARNING**

#### **Burn hazard due to hot hydraulic oil!**

Hot hydraulic oil can cause burns to the skin.

- ▶ If a hose bursts, move the control elements to neutral position so that as little hydraulic oil as possible escapes.
- ▶ Wear protective equipment.

### **Information**

Hose burst valves are set at the factory and secured with seals. The correct functioning is no longer ensured and warranty is void if a seal is removed or if the hose burst valve is tampered with.

If a hose bursts, move the control lever or stabilizer blade lever to neutral.

- Safe load indicator **Advanced**:

Load-retaining function	Safety equipment
Boom	Hose burst valve
Shovel arm	Hose burst valve
Stabilizer blade	Counterbalance valve



**Proceed as follows after a damage:**

1. Stop the vehicle immediately.
2. Stop the engine.
3. Move the control lever or stabilizer blade lever to neutral.
4. Perform emergency lowering if possible – *see chapter “5.12 Emergency lowering” on page 5-88*
5. Raise the control lever base.
6. Remove the starting key and lock the cabin.
7. Secure the vehicle and the attachment.
8. Contact a Wacker Neuson service center and have the malfunction rectified.



**Environment**

Use a suitable container to collect fluids and lubricants as they flow out and dispose of them in an environmentally friendly manner.

---

### 5.10 Attachments

#### Picking up

---



#### **WARNING**

##### **Injury hazard due to fluid escaping under pressure!**

Hydraulic oil escaping under pressure can penetrate the skin and cause serious injury or death.

- ▶ Do not allow anyone to stay in the danger zone.
  - ▶ Release the pressure in the hydraulic system before connecting or disconnecting the attachment – *see chapter “Release the pressure of the work hydraulics” on page 5-78.*
  - ▶ Wear protective clothes.
  - ▶ Always consult a doctor immediately, even if the wound seems insignificant. Hydraulic oil causes blood poisoning.
- 



#### **WARNING**

##### **Accident hazard when picking up attachments!**

Picking up attachments incorrectly can cause serious injury or death.

- ▶ Wear protective equipment during installation of the connecting pins.
  - ▶ Do not allow anyone to stay in the danger zone.
  - ▶ Only use attachments that are in perfect condition.
  - ▶ Set and adjust the boom to the correct position with the control levers.
  - ▶ Align the fastening bores in the attachment with a mandrel to make it easier to insert the pin in the bores.
  - ▶ Ensure correct locking with a rapid succession of stick and bucket movements as close as possible to the ground.
  - ▶ Operate the vehicle only with a safely locked attachment
-



### Setting down

---

#### **WARNING**

##### **Crushing hazard when attachments are removed!**

If an attachment is not removed correctly, it can tip over and cause serious injury or death.

- ▶ Do not allow anyone to stay in the danger zone.
  - ▶ Lower the attachment to level and firm ground ensuring stability.
  - ▶ Only remove the pins from the attachment if it is in a stable position.
  - ▶ Lower the attachment to the ground without too much pressure, otherwise the resistance when removing the pins is too high.
- 

The procedure of changing attachments is described below for a backhoe bucket.

Follow the special information when fitting or removing attachments with their own hydraulic functions (for example an offset bucket). Observe the Operator's Manual of the attachment.

---

#### **Information**

The hydraulic system of the vehicle is still pressurized even when the engine is not running. Due to the residual pressure, the hydraulic quick couplers can be removed but not installed back on again.

- ▶ Release the pressure.
-

## Release the pressure of the work hydraulics

1. Stop the vehicle on firm, level, and horizontal ground.
2. Lower the attachment completely to the ground.
3. Lower the stabilizer blade to the ground.
4. Stop the engine.
5. Turn the starting key to position **1**.
6. Lower the control lever base.
7. Release the pressure:
  - ➔ **Work hydraulics:** Move the control elements of the respective hydraulic circuit several times in all directions and hold each time as far as it will go for three seconds.
  - ➔ **AUX I:** ensure that the hammer return line is deactivated, for example. Select attachment **bucket**.
    - ➔ Move the control element of the respective hydraulic circuit several times in all directions and hold each time as far as it will go for three seconds.
  - ➔ **AUX II:** ensure that AUX II is selected.
    - ➔ Move the control element of the respective hydraulic circuit several times in all directions and hold each time as far as it will go for three seconds.
8. The pressure reduces. This can be seen by the brief movement the hoses make as the pressure is released.
9. Turn the starting key to position **0**.
10. Uncouple the attachment immediately after the pressure has been released, otherwise pressure can be created again.

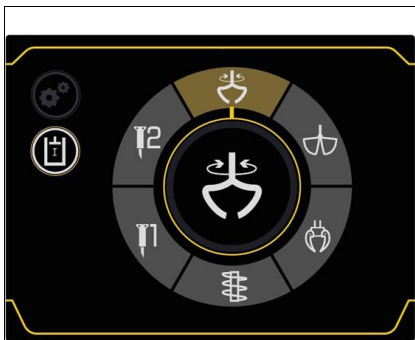


Fig. 265

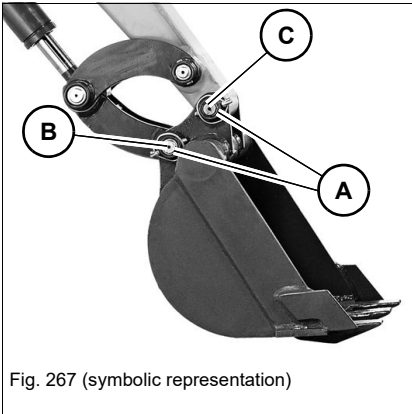


Fig. 266

Removed attachments with hydraulic connections must not be stored in sunlight to ensure pressure does not build in the lines.

Clean the hydraulic quick couplers before connecting to ensure dirt does not penetrate the hydraulic system.

## Re-equipping



### Removing

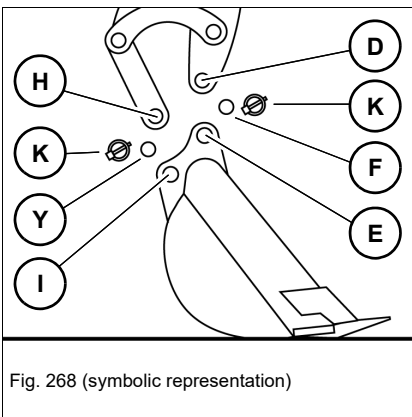
1. Lower the bucket to level ground with the flat side facing downward.
2. Stop and park the vehicle. Stop the engine. See "Preparing lubrication".
3. Remove linch pins **A**.
4. First remove pin **B**, and then pin **C**. Carefully expel pins that are stuck with a hammer and a brass punch.

If pin **C** is stuck:

1. Start the engine.
2. Slightly raise and lower the boom to take the load off the pin.
3. Stop and park the vehicle. Stop the engine. See "Preparing lubrication".
4. Raise the control lever base.
5. Remove the starting key and carry it with you.

### Information

Place the bucket only with minimum pressure on the ground as you remove the pins. The higher the pressure on the ground, the higher the resistance and the more difficult it is to remove the pins.



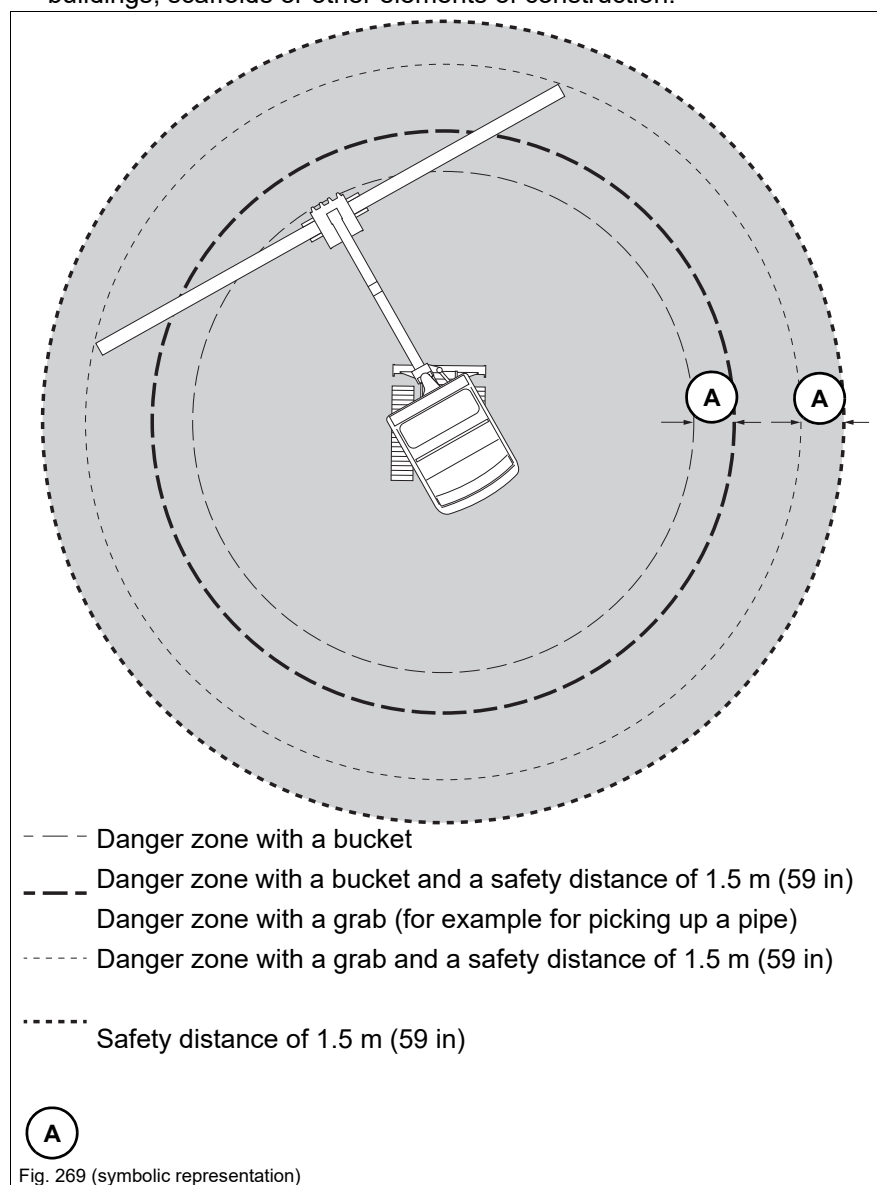
### Mount

1. Install a bucket only if it is positioned on level ground with the flat side facing downward.
2. Stop and park the vehicle. Stop the engine. See "Preparing lubrication".
3. Apply grease to the pins and joints before inserting the pins.
4. Start the engine.
5. Straighten the stick so that bores **D** and **E** are flush.
6. Stop the engine. Raise the control lever base.
7. Insert pin **F**.
8. Actuate the bucket cylinder until bores **H** and **I** are flush.
9. Stop the engine. Raise the control lever base.
10. Insert pin **J**.
11. Install linch pins **K**.

## 5.11 Work operation

### Danger zone

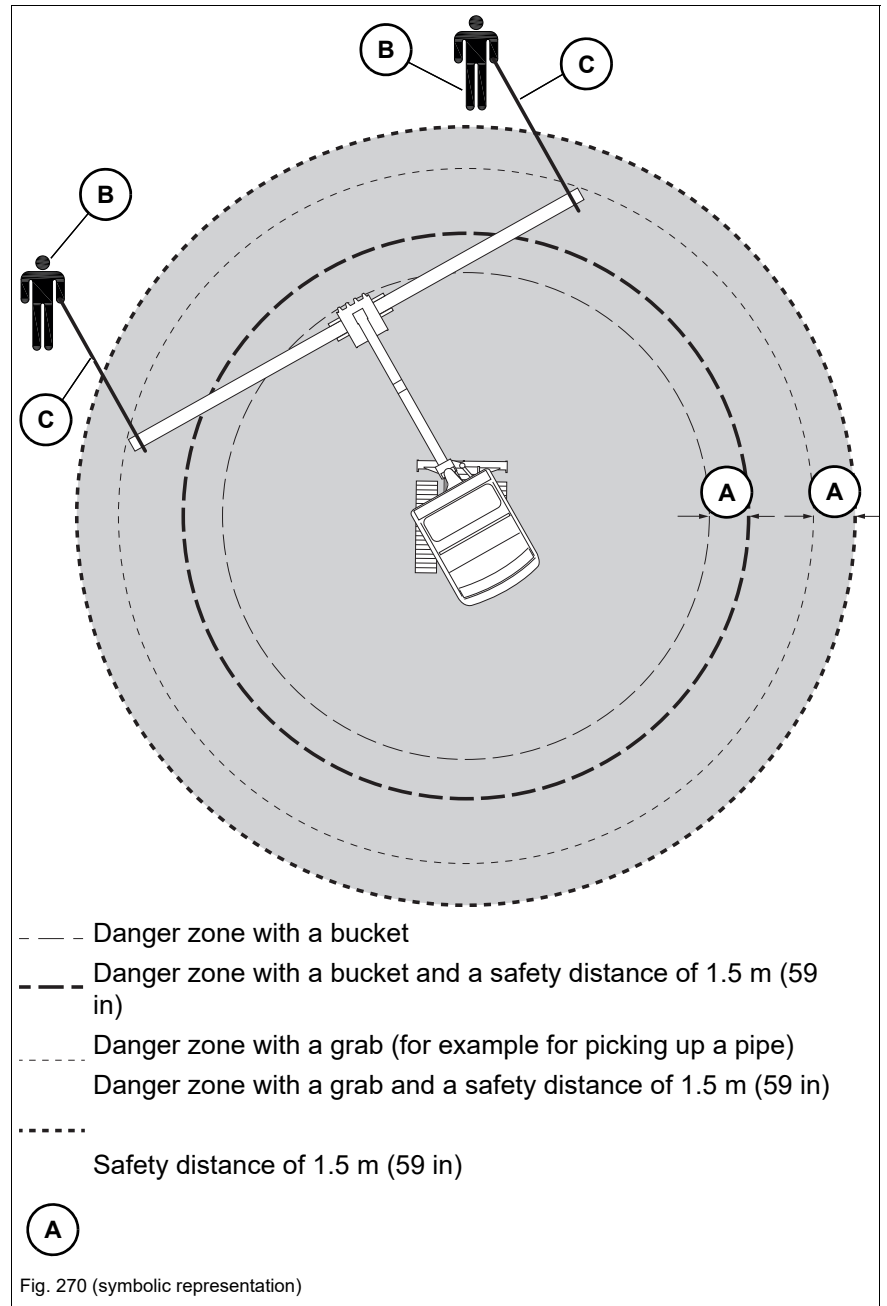
- The danger zone is the area in which persons are in danger due to the movements of the vehicle, attachment or load.
- The danger zone also includes the area that can be affected by falling material, equipment or by parts that are thrown out.
- The danger zone on a slope is different from the one on a level surface (secure the load) See chapter “**Operation, driving on slopes**”.
- Stop vehicle operation immediately if persons do not stay clear of the danger zone.
- Seal off the danger zone should it not be possible to keep a sufficient safety distance.
- Extend the danger zone sufficiently in the immediate vicinity of buildings, scaffolds or other elements of construction.



**Danger zone during lifting-gear applications**

In lifting gear applications the load must be stabilized by slingers (B) with the help of ropes (C).

Slingers must remain out of the danger zone – see chapter “Lifting gear applications” on page 5-52.



## Inadmissible work procedures

---

### **NOTICE**

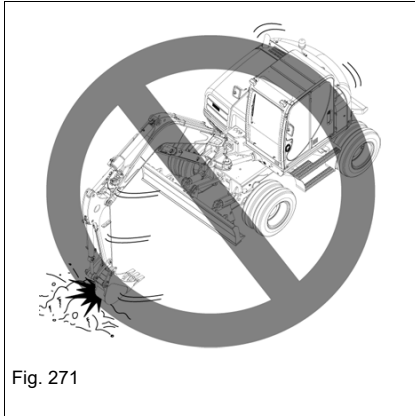
Inadmissible operation can damage the vehicle or the attachment.

---

#### **Working with the swivel force**

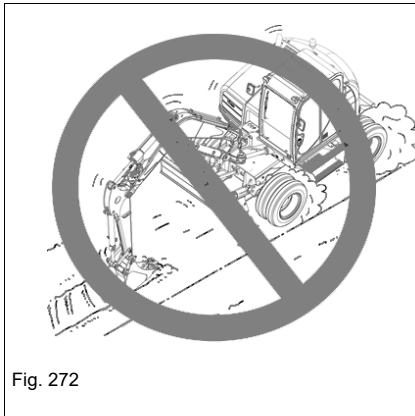
Do not use the swivel force of the upper carriage to tear down walls or to create level surfaces.

Do not ram the attachment into the ground when swiveling the upper carriage.



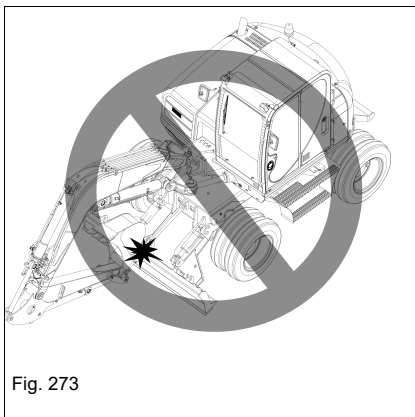
#### **Working with the drive force**

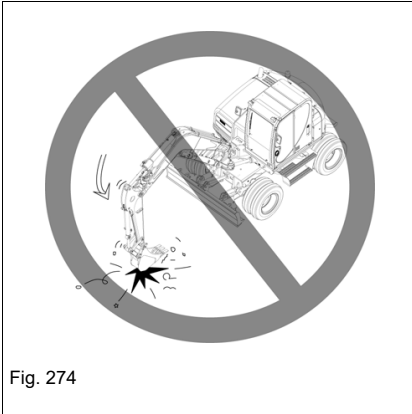
Do not ram the attachment into ground or lower the boom during vehicle travel.



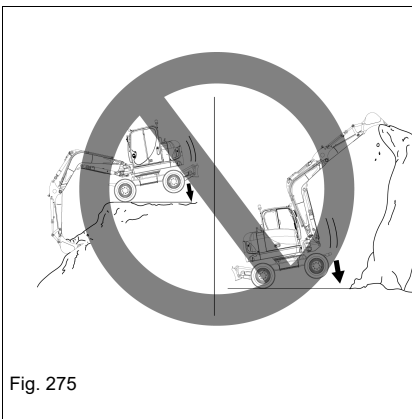
#### **Retracting the attachment**

When retracting the attachment, ensure that it does not touch the stabilizer blade.

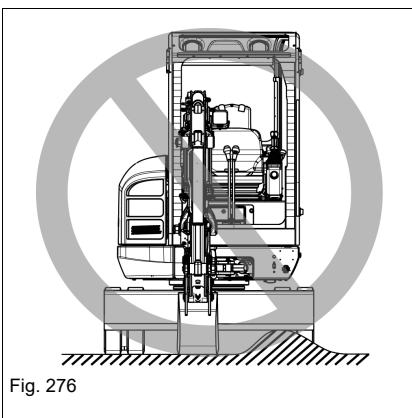


**Working with the falling force by lowering the attachment**

Do not use the falling force of the attachment as a hoe, hammer or pile-driver.

**Working with the falling force by lowering the vehicle**

Do not use the dead weight of the vehicle for work.  
Use the force of the hydraulic cylinders exclusively.

**Fully lowering the stabilizer blade**

Apply the full weight of the vehicle over the entire width of the stabilizer blade when using it for stabilization.

**Protecting the stabilizer legs/blade against shocks**

The stabilizer blade or stabilizer blade cylinder can be damaged when the stabilizer blade hits against obstacles.

## General information regarding work operation

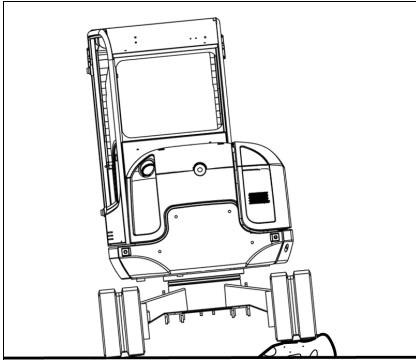


Fig. 277 (symbolic representation)

### Machine travel

Performing vehicle travel over obstacles can put a heavy load on the undercarriage and cause damage. Avoid performing vehicle travel over obstacles if possible.

If it cannot be avoided, lower the boom to ground level and travel over the obstacle at low speed.

### Performing machine travel in speed range 2 (option)

Avoid starting vehicle travel and stopping abruptly as well as changing direction suddenly on rough terrain.

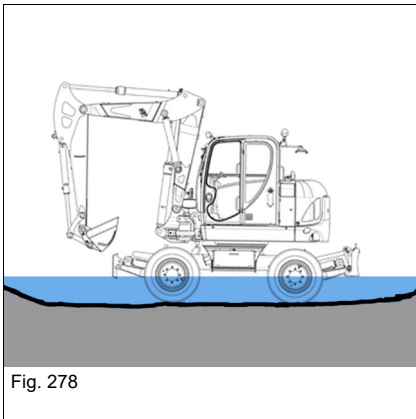


Fig. 278

### Operation in water

Water must not reach any further than to the middle of the axles.

Lubricate lubrication points again that were immersed in water for a longer time in order to expel the old grease.

Do not immerse the live ring and upper carriage in the water.

Operation in salt water is prohibited.

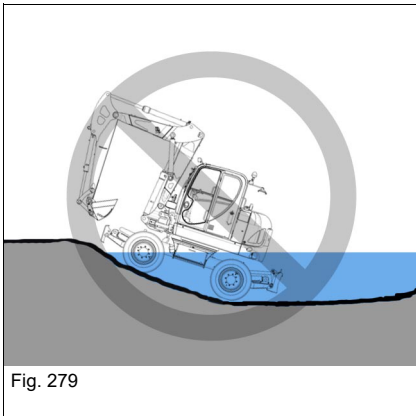


Fig. 279

Do not immerse the live ring and upper carriage in the water.

### Operation near the sea

Clean the vehicle regularly when using it in a saline environment.

See chapter **Cleaning and maintenance**.

## Working with the bucket

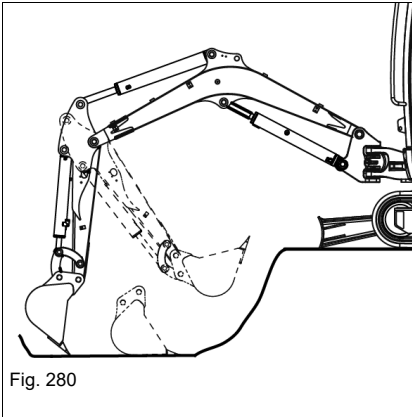
The following section describes work operations with the vehicle equipped with a backhoe bucket. The backhoe bucket is mainly used for earth-moving applications (digging, loosening, picking up and loading loose or solid material).

Place the stabilizer blade on the side you want to dig.

### Bucket position when digging

Perform long, level excavation movements with the stick and the bucket. The maximum excavation force is achieved at an angle of 80 to 120° between the boom and the stick.

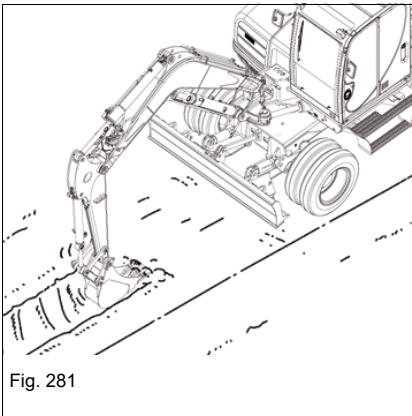
1. Penetrate into the ground with the bucket.
2. Lower the stick and at the same time, position the bucket so that the flat lower side of the bucket is parallel with the ground.
3. Move the stick toward the vehicle and tilt in the bucket at the same time.



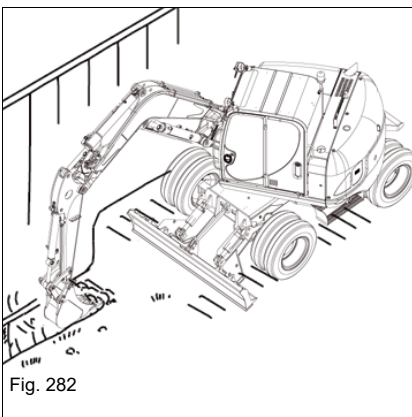
### Working alongside trenches

For an efficient working method, install a suitable bucket and set the wheels parallel to the trench.

When digging wide trenches, dig the side sections first and then the middle section.



For excavating laterally in tight spaces, turn the upper carriage and swivel the boom.



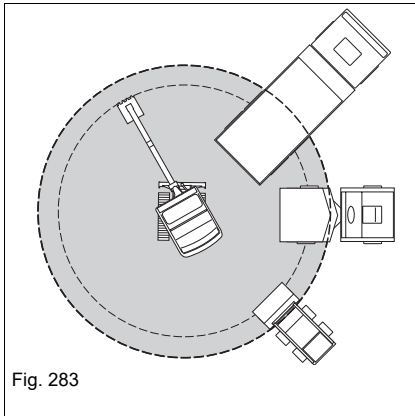


Fig. 283

### Loading material

Notes on loading site dumpers:

- Position the site dumper so that its cabin is outside the danger zone of the excavator.
- The loading platform of the truck is loaded by starting at the rear end.
- Keep the swivel angle as small as possible.
- Raise the full bucket to dump height only as you rotate toward the site dumper.
- Tilt out dusty material with the wind behind you to keep the dust away from your eyes, air filters and fans.
- If possible, the site dumper and the working direction of the bucket should form an angle of 45°.

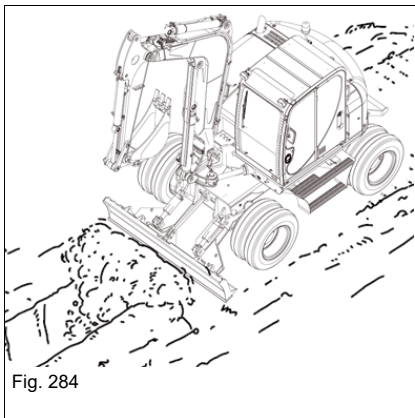


Fig. 284

### Grading

The stabilizer blade is used for filling up trenches or grading the ground. Lower the stabilizer blade to the ground for grading work.

Set the depth of the layer you want to remove with the stabilizer-blade lever.

- The vehicle must not be raised by lowering the stabilizer blade.
- Do not dig in the vehicle or let it sink in.

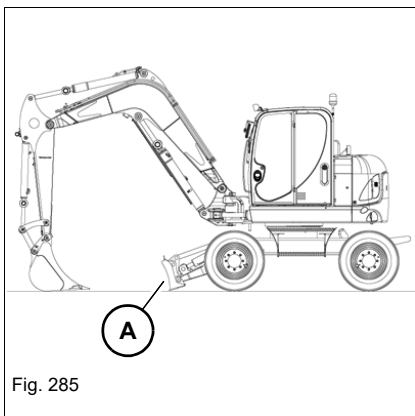


Fig. 285

### Digging position

Place stabilizer blade **A** on the side you want to dig.

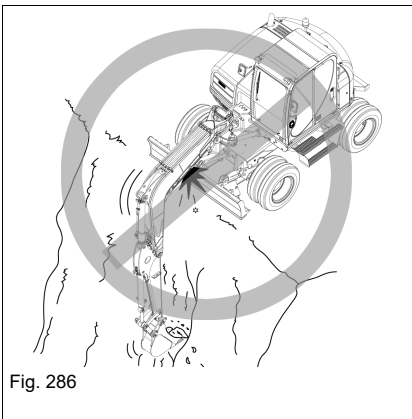
## Working on slopes

### **WARNING**

#### **Tipping hazard of machine on slopes!**

A tipping vehicle can cause serious injury or death.

- ▶ Secure slopes before beginning work. Pay attention to ground conditions, vehicle weight, etc.
- ▶ Stabilize the machine with stabilizer legs or the stabilizer blade during excavation work.



### **NOTICE**

Lifting arm cylinders can be damaged by improper operation.

- ▶ The piston rod must not touch the dozer blade, the stabilizer legs or the transport bar for clamshell bucket.

### Further **recommendations for digging**

When planning and performing digging work, Wacker Neuson recommends that you observe the following points:

- Exits from pits must be outside the digging line and as level as possible.
- Dig by removing adjacent strips if possible.
- Ensure that you can drive forward when driving out of the digging area with a fully loaded bucket.
- Perform transport trips downhill with loaded bucket in reverse operation.

### **Freeing the vehicle**

If the vehicle gets stuck in the ground:

- Tilt out the bucket until the blade is vertical above the ground.
- Lower the boom all the way.
- Slowly tilt out the bucket.
  - ➔ The vehicle is pushed backward.
- Reverse slowly.
- Repeat this procedure until the wheels reach firm ground.
- Reverse the vehicle away.



### 5.12 Emergency lowering

---



#### **WARNING**

##### **Crushing hazard during boom lowering!**

Causes serious crushing or injury resulting in death.

- ▶ Do not allow anyone to stay in the danger zone.
  - ▶ Stop vehicle operation immediately as soon as someone enters the danger zone.
- 

Observe the following during emergency lowering:

1. Turn the starting key to position **1**.
  2. Lower the control lever base.
  3. Lower the boom completely.
  4. Return the joystick to neutral.
- 



#### **Information**

Lower the boom immediately after stopping the engine.

---

## 5.13 Options

### Immobilizer (option)

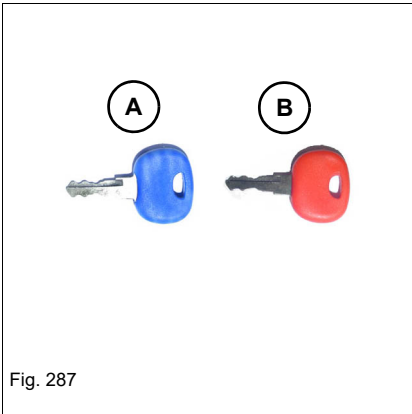


Fig. 287

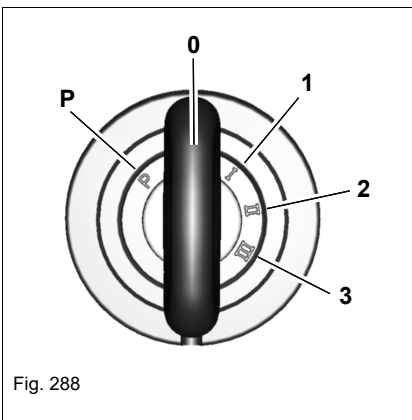


Fig. 288

**A** = starting key (blue)

For starting the vehicle. Scope of delivery includes 2 keys.

**B** = master key (red)

#### Coding new starting keys

1. Insert master key **B** in the starter and turn it to position **1** for a maximum five seconds.
  2. Remove master key **B**.
  3. Keep master key **B** at least 50 cm (20 in) away from the starter.
  4. Within 15 seconds, turn starting keys requiring coding to position **1** for at least one second.
  5. Repeat step 4 if more starting keys require coding.
- With this, the coding of the starting keys is completed.
- Coding can be performed for a maximum of 10 starting keys.

#### **i** Information

The procedure is automatically canceled if no key requiring coding is detected by the system within 15 seconds.

#### Deleting coded keys

Deleting all coded keys is necessary whenever a coded key is lost. The master key code is not deleted during deletion.

1. Insert master key **B** in the starter and turn it to position **1** for at least 20 seconds.
2. Code the starting keys.

#### **i** Information

Store the master key in a safe place. It can only be used for coding new starting keys. A new immobilizer must be installed if the master key is lost.

### Drive interlock EquipCare Dual ID



Fig. 289

The EquipCare dual ID drive interlock can be available in relation with **telematics**. Store the PIN on [equipcare.wackerneuson.com](https://equipcare.wackerneuson.com). The vehicle can only be started with the correct PIN.

Position	Element	Function
A	LED 1	Lights up in yellow, when the keypad is ready for operation
B	LED 2	Not assigned
C	LED 3	Lights up in green, when the PIN is correct Does not light up, when the PIN is wrong
D	Confirm	Confirm PIN
E	Cancel	Cancel input

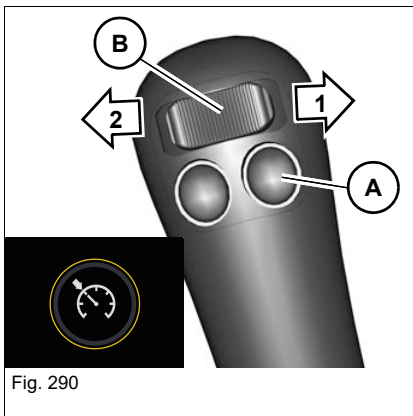
When the keypad is in sleep mode, start ignition.

**Travel speed control (option)**

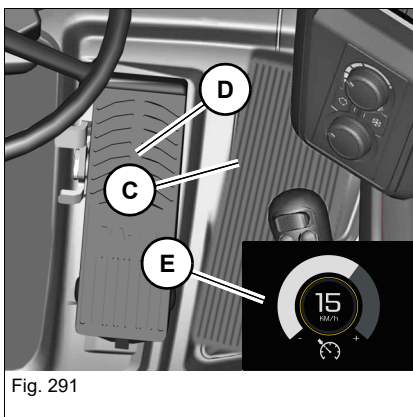
**WARNING**
**Accident hazard with travel speed control enabled!**

The machine travels at constant speed with the travel speed control. If it is used incorrectly, it can cause accidents with serious crushing or death.

- ▶ Disable the travel speed control during uphill or downhill travel.
- ▶ Disable the travel speed control in dense traffic.
- ▶ Disable the travel speed control on winding or slippery roads.


**Enable**

1. Select the required speed with accelerator pedal **C**
2. Enable the travel speed control with push button **A** on the control lever on the right.
  - The travel speed control symbol is displayed in the multifunctional display for a few seconds.



3. In road-travel mode the set speed can also be increased (**1**) or reduced (**2**) during machine travel with switch **B**.

Indication **E** appears in the multifunctional display during speed setting.

**Disabled**

The travel speed control is disabled in one of the three following cases:

- Press brake pedal **D**
- Press push button **A**
- After changing the travel direction


**Information**

On the 30 kph version, the travel speed control cannot be switched on in operating mode and speed range 2.

### Shovel bucket operation

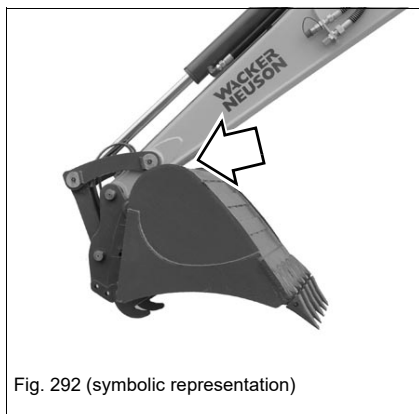


Fig. 292 (symbolic representation)

---

#### **NOTICE**

The stick can be damaged if it is hit by the bucket base.

- ▶ Do not tilt out the bucket completely if it is used as a shovel bucket.
- 

### Trailer operation

The vehicle is not certified for trailer operation!

## 5.14 Putting out of operation/back into operation

The specified measures refer to putting the vehicle out of operation and back into operation after more than 30 days.

### Putting out of operation temporarily

Store the vehicle indoors if possible.

If the machine has to be stored outdoors, place it on firm ground if possible (for example on concrete), and cover it with a watertight tarp to protect it against humidity.

1. Park the vehicle – *see “Parking the machine” on page 5-27.*
2. Clean the engine with a high-pressure cleaner in a suitable place – *see chapter “7.5 Cleaning and maintenance” on page 7-29.*
3. Check the vehicle for leaks and loose nuts, screws and connections.
4. Carefully clean and dry the entire vehicle.
5. Spray an anticorrosion agent onto bare metal parts of the machine (piston rods of hydraulic cylinders, for example).
6. Apply grease to all lubrication points.
7. Fill the fuel tank completely.
8. Check the hydraulic oil and coolant levels, and add hydraulic oil and coolant if necessary.
9. Remove the battery and store it in a safe place. Charge the battery and perform battery maintenance at regular intervals.
10. Close the air-intake openings of the air filter system and exhaust pipe.

### Putting back into operation

---

#### **Information**

If the vehicle was out of operation over a longer period of time without performing the specified steps, contact a Wacker Neuson service center before putting back into operation.

---

1. Perform a general visual check for damage on the electric cables, connectors, fuel lines, corrosion, etc. on the engine and diesel particulate filter.
2. Start the engine once a month to ensure optimal lubrication.
3. Remove anti-corrosion agents from bare metal parts.
4. Charge, install and connect the battery.
5. Open the air-intake openings of the air filter system and exhaust pipe.
6. Check the condition of the air filter elements and have them replaced by a Wacker Neuson service center if necessary.
7. Check the dust valve.
8. Bleed the fuel system – see [“Fuel filter” on page 7-37](#)
9. Check the vehicle for leaks.
10. Lubricate the vehicle according to the lubrication plan.
11. Check all engine/vehicle fluids in the units or reservoirs, and add fluids if necessary.
12. If the vehicle was out of service for over 6 months, have the oil in the gearbox, engine, hydraulic oil reservoir and other units changed by a Wacker Neuson service center.
13. Have the hydraulic oil filters (pressure, return and breather filters), the engine oil filter and diesel filter (prefilter and main filter) by a Wacker Neuson service center if the vehicle was out of operation for over 6 months.
14. Switch on the starter and check whether there are any malfunctions. – see [“Malfunctions” on page 8-1](#)  
Contact an authorized service center and have the malfunction rectified.
15. Start the engine.
16. Let the engine run at idling speed at least 15 minutes without load.
17. Stop the engine.
18. Check the oil levels in all units and add oil if necessary.
19. Check the vehicle for leaks.
20. Start the engine and ensure that all functions and warning systems work correctly.

Avoid operation at maximum engine speed or load for more than an hour.

## 5.15 Permanently putting out of operation

### Disposal

All fluids, lubricants, material, etc., used on the vehicle are subject to specific regulations. Dispose of different materials and consumables separately and in an environmentally friendly manner.

Disposal may only be performed by a Wacker Neuson service center. Observe the national and regional regulations for disposal.

---



### **Environment**

Do not allow environmentally damaging wastes to get into the ground or stretches of water and dispose of them in an environmentally friendly manner.

---

If the vehicle is no longer used according to its designated use, ensure that it is put out of operation and disposed of according to national and regional regulations.

- Machine disposal must be performed in accordance with state-of-the-art standards that apply at the time of disposal.



Notes:

## **6 Transportation**

### **6.1 Towing the vehicle**

---



#### **WARNING**

##### **Accident hazard due to incorrect towing!**

Incorrect towing can cause accidents and serious injury or death.

- ▶ Tow the machine away only from the immediate danger zone until it can be loaded.
  - ▶ Never tow downhill.
  - ▶ Only tow the vehicle using suitable towing equipment in connection with suitable towing facilities, such as towing hooks, eyes, etc.
  - ▶ There must be nobody between the vehicles during towing. The lateral safety distance is equal to 1.5 times the length of the towing equipment.
  - ▶ Do not tow the vehicle if it is stuck or on a slope. Load the vehicle.
  - ▶ Steering requires greater effort if the diesel engine breaks down. Due to the emergency steering feature, the machine reacts only very slowly to the steering movements.
  - ▶ The machine cannot be steered when the hydraulic oil reservoir is empty.
  - ▶ Allow the traveling drive to cool down.
  - ▶ Wear protective equipment.
  - ▶ Start vehicle travel and tow away slowly.
- 



#### **WARNING**

##### **Accident hazard due to incorrect towing!**

The closed hydraulic circuit empties itself when towing with the bypass enabled. Therefore this can cause unexpected machine handling when the machine is started again. This can cause accidents with serious injuries or death.

- ▶ Put the traveling drive into operation only after having completely filled and bled the hydraulic circuit.
  - ▶ Have bleeding performed only by a Wacker Neuson service center.
-



### **CAUTION**

#### **Burn hazard due to hot surfaces!**

Higher towing speeds and longer towing distances cause heat to develop. This can cause serious burns.

- ▶ Only tow the machine out of the immediate danger zone until it can be loaded. Do not tow the machine farther than 50 meters (165 ft).
  - ▶ Wear protective equipment.
- 



### **WARNING**

#### **Crushing hazard due to vehicle rolling away under its own weight after parking it!**

Serious injury or death can be caused by not securing the vehicle.

- ▶ The machine may only be towed on level ground or uphill.
  - ▶ Secure the machine at the tie-down points with slings of sufficient dimensions.
  - ▶ Secure the machine with chocks to prevent it from rolling.
-



---

**NOTICE**

The vehicle can be damaged during towing.

- ▶ Only tow the machine out of the immediate danger zone until it can be loaded. Do not tow the machine farther than 50 meters (165 ft).
  - ▶ Do not tow the vehicle if it is stuck or on a slope. Load the vehicle.
  - ▶ Only tow the vehicle using suitable towing equipment in connection with suitable towing facilities, such as towing hooks, eyes, etc.
  - ▶ A tractor vehicle of the same weight category must be used as a minimum.  
In addition, the tractor vehicle must be equipped with a safe braking system and sufficient tractive power.
- 



**Information**

The machine may not be used on public roads for towing another machine.

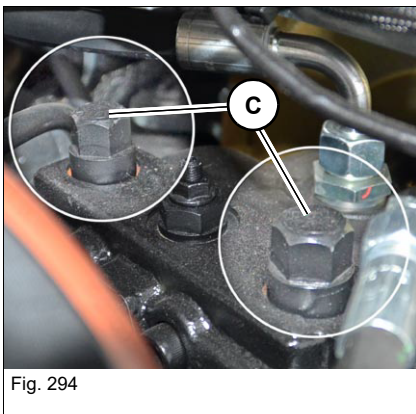
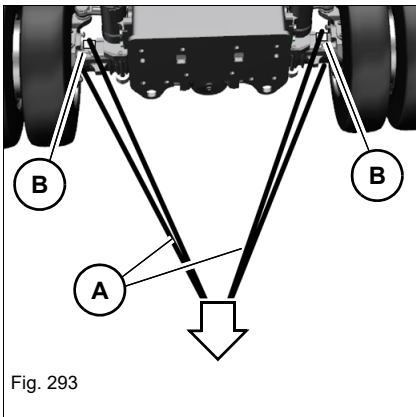
---

### Towing variant 1 (engine cannot be started, parking brake can be released)

The high pressure limiting valves of the hydraulic pump must be opened for towing.

The hydraulic pump is located on the left in the engine compartment.

1. Ensure that the vehicle can be towed safely.
2. Stop the diesel engine.
3. Secure the machine with chocks to prevent it from rolling.
4. Install the towing equipment on the towing vehicle with suitable slings and tighten the towing equipment so that the machine cannot move any more.
5. Put sling **A** around the front or rear axle.
6. Use edge guard **B**.



7. Open the engine cover – see chapter “Opening the engine cover” on page 7-26.
8. Loosen the pressure relief valves with three anticlockwise revolutions of nuts **C**.
9. Remove the wheel chocks.
10. Start the engine.
11. Release the parking brake.
12. Steering requires the operator to be in the machine. The machine can be towed.
13. Start machine travel slowly.
14. Tow the machine out of the immediate danger zone at a max. 4 kph (3 mph) until it can be loaded.

#### Information

Have the machine only repaired by a Wacker Neuson service center.

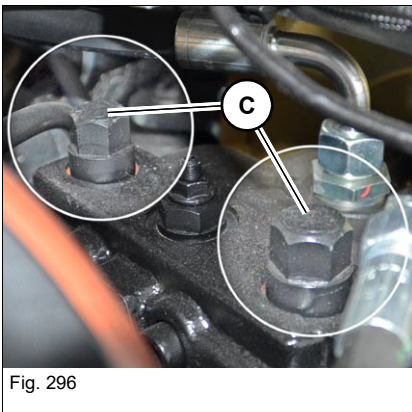
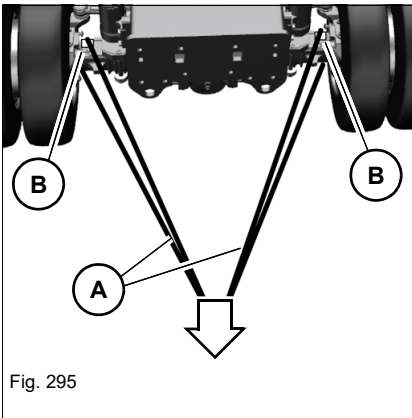
### Towing variant 2 (engine cannot be started, parking brake cannot be released)

The high pressure limiting valves of the hydraulic pump must be opened for towing, and the parking brake must be released manually.

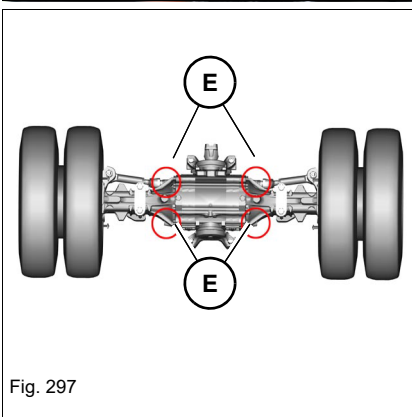
The hydraulic pump is located on the left in the engine compartment.

The screws for the parking brake are located at the rear axle.

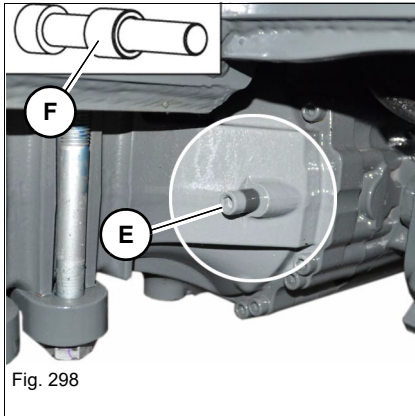
1. Ensure that the vehicle can be towed safely.
2. Secure the machine with chocks to prevent it from rolling.
3. Install the towing equipment on the towing vehicle with suitable slings and tighten the towing equipment so that the machine cannot move any more.
4. Put sling **A** around the front or rear axle.
5. Use edge guard **B**.



6. Open the engine cover – see chapter “Opening the engine cover” on page 7-26.
7. Loosen the pressure relief valves with three anticlockwise revolutions of nuts **C**.



8. Unscrew the four screws **E** at the rear axle anticlockwise.



9. Remove distance pieces **F** and screw in the four screws **E** clockwise until you can feel a resistance.
10. With one quarter clockwise turn each time, tighten both left screws **E** alternately five times to 25 Nm (18 ft.lbs).
11. Repeat the procedure on the right side of the axle.
12. Remove the wheel chocks and slings.
13. Steering requires the operator to be in the machine. The machine can be towed.
14. Start machine travel slowly.
15. Tow the machine out of the immediate danger zone at a max. 4 kph (3 mph) until it can be loaded.



### Information

Have the machine only repaired by a Wacker Neuson service center.

## 6.2 Loading the vehicle

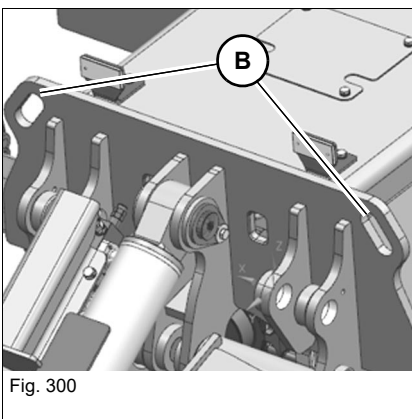
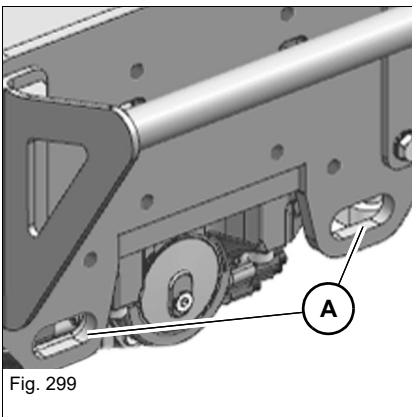
### **WARNING**

#### **Accident hazard due to incorrect loading!**

Incorrect loading can cause accidents and serious injury or death.

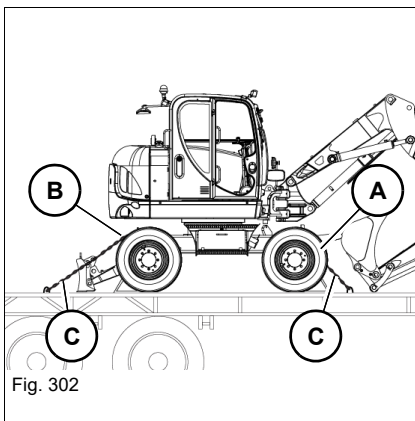
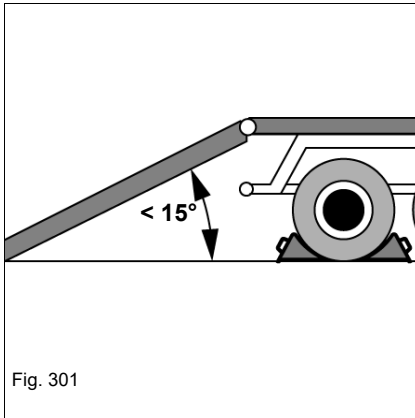
- ▶ Do not allow anyone to stay in the danger zone.
- ▶ Bear in mind the transport weight on the vehicle's type label.
- ▶ Tie down the vehicle only at the indicated tie-down points.
- ▶ Observe the loading weight. Add the weight of subsequently installed accessories to the weight of the vehicle.

### Tie-down points



The machine is equipped with four tie-down points.

Position		Quantity
<b>A</b>	Front of travel gear	2
<b>B</b>	Rear of travel gear	2
--	Stabilizer blade	--
--	Parallel stabilizer blade	--
--	Stabilizer legs	--



1. – see chapter “Transportation” on page 2-15
2. Secure the transport vehicle with chocks to prevent it from rolling.
3. Install access ramps at the smallest possible angle. Ensure that the grade does not exceed 15° (27%).
4. Use access ramps and transport surfaces with an anti-skid surface only.
5. Ensure that the loading area is clear and access to it is not obstructed, for example by superstructures.
6. Start the engine.
7. Raise the boom and the stabilizer blade to avoid touching the access ramps.
8. Carefully drive the vehicle onto the middle of the transport vehicle.
9. Move the vehicle to transport position:
  - Position the boom straight ahead at the center of the vehicle.
  - Lower the boom and the stabilizer blade.
10. Stop the engine.
11. Raise the control lever base.
12. Remove the starting key and carry it with you.
13. Leave the cabin, close and lock all doors, windows and covers.
14. Firmly fasten the vehicle on the loading area with tie-down points **A** and **B** with slings **C** of appropriate size. Observe the national and regional regulations.

## Crane-lifting

---

 **WARNING****Accident hazard due to incorrect loading!**

Incorrect loading can cause accidents and serious injury or death.

- ▶ Do not allow anyone to stay in the danger zone.
  - ▶ Bear in mind the transport weight on the vehicle's type label.
  - ▶ Observe the loading weight. Add the weight of subsequently installed accessories to the weight of the vehicle.
  - ▶ The vehicle may only be raised with suitable lifting gear.
- 

**NOTICE**

Possible damage to the vehicle due to incorrect loading.

- ▶ Bear in mind the transport weight on the vehicle's type label.
  - ▶ Observe the loading weight. Add the weight of subsequently installed accessories to the weight of the vehicle.
  - ▶ The vehicle may only be raised with suitable lifting gear.
- 

 **Information**

The manufacturer's warranty shall not apply to accidents or damage caused by loading or transporting.

---

### Lifting eyes

The vehicle must only be raised using the lifting eyes indicated below.

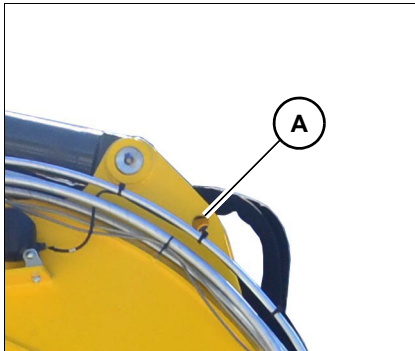


Fig. 303

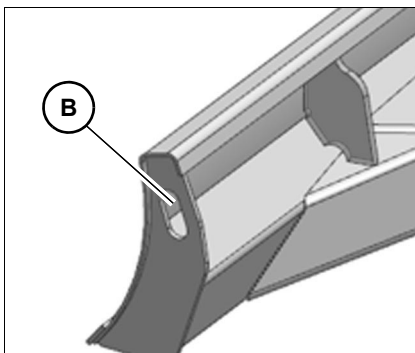


Fig. 304 (symbolic representation)

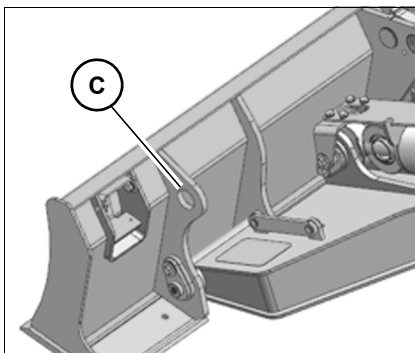


Fig. 305 (symbolic representation)

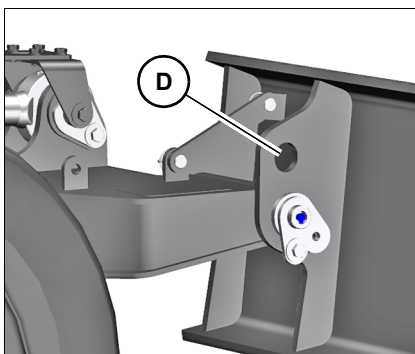


Fig. 306 (symbolic representation)

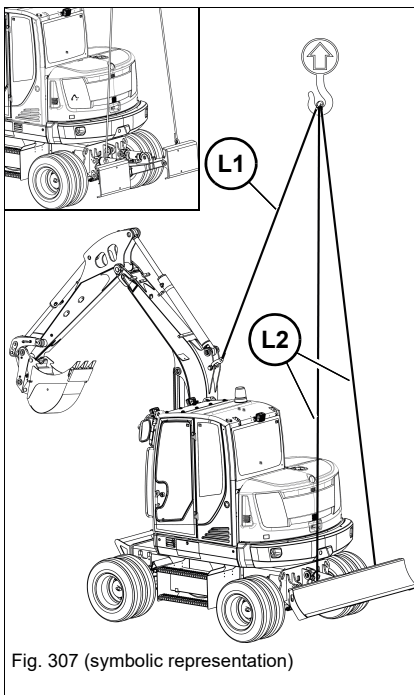
Position		Quantity
A	Boom (one-piece boom)	2
	Boom (triple articulation boom)	1
B	Stabilizer blade	2
C	Parallel stabilizer blade	2
D	Stabilizer legs	1 per stabilizer leg

#### **i** Information

The total number of lifting eyes depends on the machine equipment.

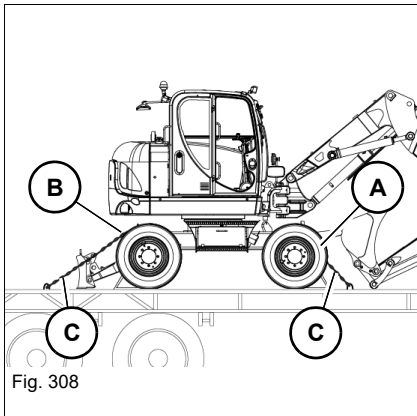
Ensure that the lifting gear has the required lengths **L1** and **L2**

Boom	Length	Dimensions
One-piece boom	L1 (dozer blade)	4100 mm (13'-5")
	L1 (stabilizer)	4400 mm (14'-5")
	L2 (stabilizer blade)	6000 mm (19'-8")
	L2 (stabilizer leg)	6300 mm (20'-8")
Triple articulation boom	L1 (dozer blade)	3900 mm (12'-10")
	L1 (stabilizer)	4200 mm (13'-9")
	L2 (stabilizer blade)	6000 mm (19'-8")
	L2 (stabilizer leg)	6300 mm (20'-8")



1. Fit an empty bucket and lock it safely.
2. Remove all dirt from the vehicle.
3. Park the vehicle on firm, level, and horizontal ground.
4. Tilt in bucket.
5. Raise the loader unit completely.
6. Pull the stick toward the vehicle.
7. Install the rotation interlock on the upper carriage – *see chapter “Installing the rotation interlock on the upper carriage” on page 5-15.*
8. Apply the parking brake.
9. Lock the service brake.
10. Completely raise the stabilizer blade/legs.
11. Position the boom straight ahead at the center of the vehicle.
12. Stop the engine.
13. Raise the control lever base.
14. Remove the starting key and carry it with you.
15. Safely store all loose objects.
16. Leave the cabin, close and lock all doors, windows and covers.
17. Attach slings on the lifting eyes.
18. Slowly raise the vehicle until there is no more contact with the ground.
19. Let the vehicle swing until it comes to rest.
20. If the vehicle balance, and the condition and position of the slings is correct, slowly raise the vehicle to the required height and load it.

### 6.3 Transporting the vehicle



1. Firmly fasten the machine on the loading area with tie-down points **A** and **B** with slings **C** of appropriate size. Observe the legal regulations.
2. The driver of the transport vehicle must observe the following before departure:
  - Permitted overall height, width and weight of the transport vehicle including the excavator.
  - The legal regulations of the countries where transport is to take place.
3. Close the exhaust pipe before transporting the vehicle through wet weather.

---

**i** **Information**

The automatic swivel unit brake secures the upper carriage against rotation.

---

---

**i** **Information**

The manufacturer's warranty shall not apply to accidents or damage caused by loading or transporting.

---

## 7 Maintenance

### 7.1 Information on maintenance

- Maintenance and care significantly affect the functionality and service life of the vehicle.
- Daily and weekly maintenance work is to be performed by the driver in accordance with the maintenance plan.
- Maintenance with the note **authorized service center** must be performed only by the trained and qualified personnel of an authorized service center.
- Defective components must be repaired or replaced before putting the vehicle into operation. Safety-relevant components may only be repaired/replaced by an authorized service center.
- Observe all risk indications and safety instructions given in this Operator's Manual.
- Follow the maintenance and safety instructions given in the Operator's Manuals of the attachments.
- Wear protective equipment (for example hard hat, safety glasses, protective gloves, safety boots).
- Attach a warning label to the control elements (for example "**Machine being serviced, do not start**").
- Stop the vehicle (see **Preparing lubrication**).
- In order to avoid damage to electronic components, do not perform welding work on the vehicle, add-on parts or tools. Contact a Wacker Neuson service center.



#### **Information**

Maintenance that has to be performed by the operator is indicated on the maintenance label.

---

## 7.2 Maintenance overview

### Maintenance label 404D/404 F

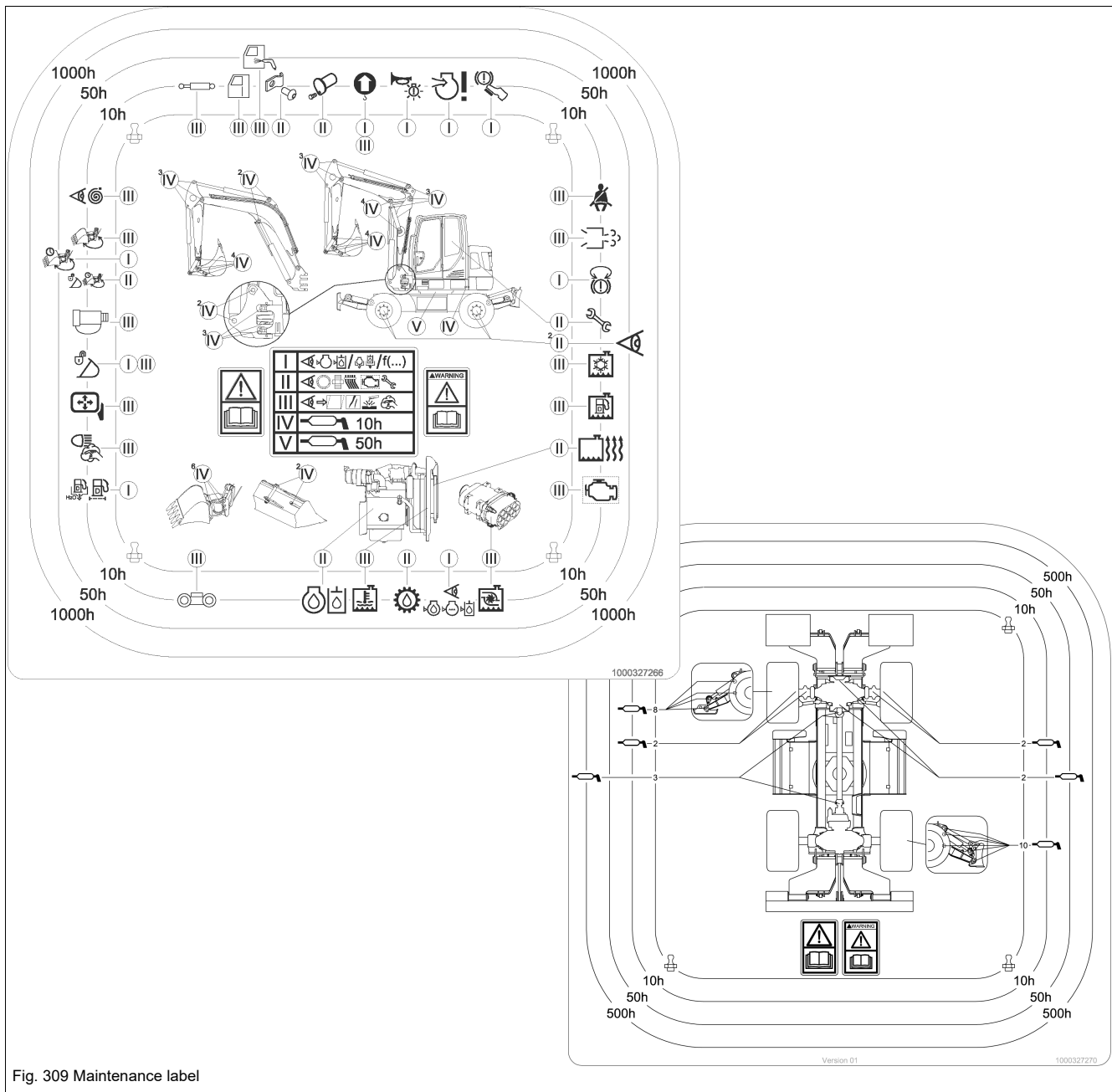


Fig. 309 Maintenance label

I = Top off and drain fluids, lubricants; Check vehicle functions.

II = Check wear parts, seals, hoses, and screw connections.

III = Check for damage, corrosion, and dirt.

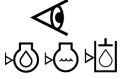












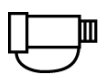


IV = Lubricate daily after the work shift.









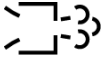




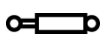

V = lubricate once a week after the work shift.

Figures and superscript numbers, for example <sup>2</sup>: number of lubrication points














## Maintenance plan

Daily maintenance (operator)		
Symbol	Inspection work (Check the following fluids and lubricants, check the oil levels after a test run and add oil if necessary)	Page
	Check the fluids and lubricants (engine oil, engine coolant, hydraulic oil)	7-41; 7-44; 7-48
	Check the radiator and hydraulic oil cooler for dirt, clean them if necessary	
	Check the charge-air cooler for dirt, clean it if necessary (404F-E22TA)	7-45
	Check the diesel cooler for dirt, clean it if necessary (404F-E22TA)	
	Lubricate the vehicle according to the lubrication schedule	7-9
	Check the water separator (pre-filter) and fuel filter on sight glass; drain water if necessary	7-37
	Water separator (prefilter) and fuel filter: drain water according to indicating element	
	Check the engine air intake	7-46
	Check the pin locks	--
	Check line fixtures	--
	Check the indicator lights and acoustic warning devices	4-36; 5-33; 5-31
	Check the service and parking brake function	5-8
	Check the swivel unit brake for correct function	5-40
	Check the hydraulic couplings for dirt	--
	Check the threaded fittings of the protective structures (for example the cabin) for tightness	--
	Clean the lights/light system, signaling systems	--

Daily maintenance (operator)		
	Safe load indicator: check the acoustic warning system	<a href="#">5-52</a>
	Hydraulic quickhitch (Easy Lock): check the acoustic warning system	<a href="#">5-60</a>
	Lubricate the Powertilt according to the lubrication schedule	<a href="#">7-16</a>
	Adjust the mirrors correctly, clean them and check them for damage, check the fastening screws and tighten them if necessary	<a href="#">4-18</a>
--	Clean fresh-air and recirculated-air coarse filters with compressed air (heating, air conditioning)	<a href="#">7-28</a>
Leakage check		
Check for tightness, leaks and chafing: pipes, flexible lines and screw connections of the following assemblies and components. Repair if necessary		Page
	Engine and hydraulic system	--
	Travel drive	--
	Cooling systems, heating, and hoses (visual check)	--
	Hydraulic quickhitch (Easy Lock) and Powertilt (hoses, valve)	--
Visual check		
Correct function; deformations, damage, surface cracks, wear and corrosion		Page
	Check the exhaust system for damage	--
	Check the insulating mats in the engine compartment for damage	--
	Check the cabin and protective structures for damage (for example the Front Guard, FOPS)	--
	Check the wheels for damage	--
	Check the travel gear for damage (for example the track rollers, insert rolling bearings)	--
	Check the piston rods of the cylinders for damage	--
	Check the seat belt for damage	--



Daily maintenance (operator)		
	Check the tire pressure and correct the pressure as required	--
	Check the hydraulic hoses for damage	--
	Check the load hook, joint rod and lifting eyes	--
	Check the hydraulic quickhitch (Easy Lock) for damage	--
	Check the Powertilt for damage	--
Weekly maintenance (every 50 operating hours) (operator)		Page
	Lubricate the vehicle according to the lubrication schedule	7-9
	Check the axle mounting (visual check)	--
	Check the wheel nuts (visual check)	--
	Check accesses and exits for dirt	--
	Replace the air filter <sup>1</sup>	--
	Actuate the Powertilt swivel device in the limit positions in both flow directions for one minute each to rinse the system	--
All steps for maintenance intervals once a day		--

1. Replace the air filter according to the multi-functional display, every 1000 o/h or once a year at the latest.  
When in extensive use in environments with acidic air (for example acid production facilities, steel and aluminum mills, chemical plants and other nonferrous-metal plants): replace after 50 o/h without regard to multi-functional display. Contact a Wacker Neuson service center.

<b>Only once after the first 50 operating hours (Wacker Neuson service center)</b>	
Replace the hydraulic oil filter	--
Replace the boost-pressure filter	--
Replace the gearbox oil in the traveling drive, axles and transfer gearbox	--
Check V-belt condition and tension	--
Check the threaded fittings for tightness	--
Check labels and Operator's Manual for completeness and condition	--
Check the pressure of the primary pressure limiting valves (operating hydraulics)	--
Reset the maintenance meter	--
Retighten the axle mounting	--
Retighten the wheel nuts	--
All steps for maintenance once a day and once a week	--

**Other maintenance intervals (Wacker Neuson service center):**

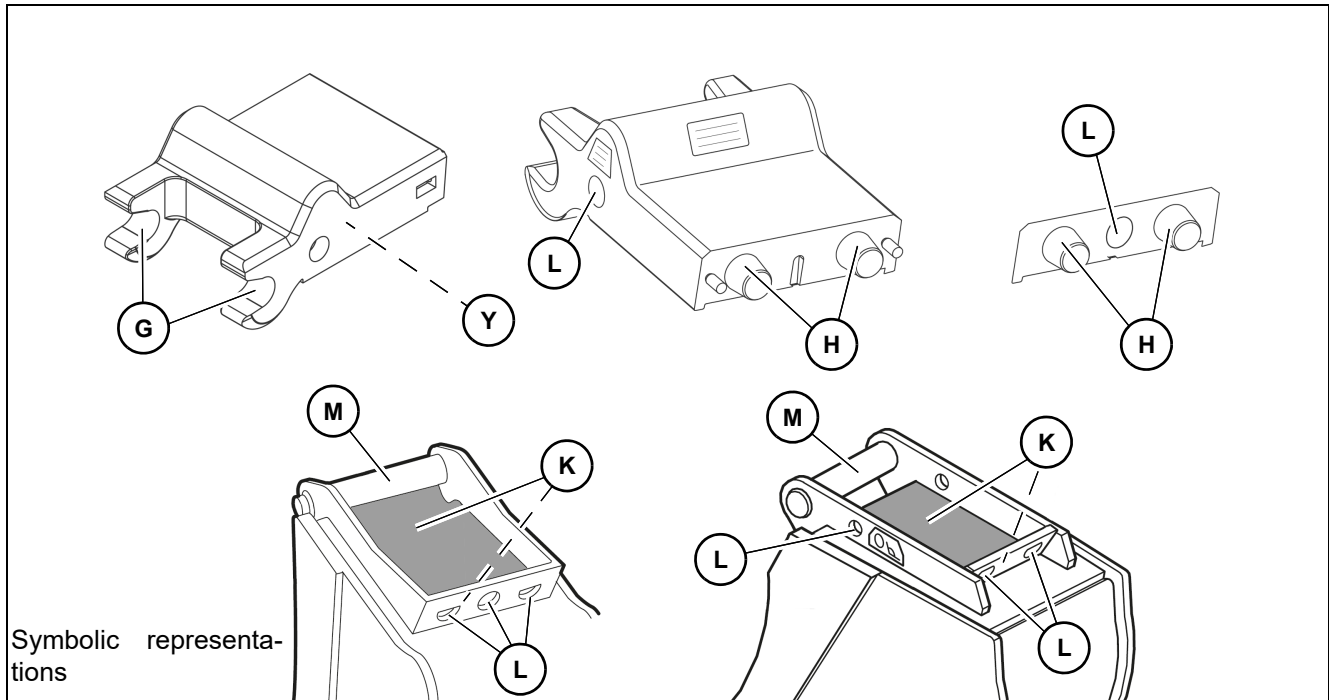
- Every 500 operating hours or annually
- Every 1000 operating hours
- Every 2000 operating hours
- Every 3000 operating hours

For additional details, contact a Wacker Neuson service center.


**Information**

Maintenance with the note **Wacker Neuson service center** must only be performed by the trained and qualified personnel of a Wacker Neuson service center.

**Maintenance schedule of Lehnhoff mechanical quickhitch system**



Quick coupler system MS03 maintenance (operator)		Interval <sup>1</sup>
Perform visual inspection of the quickhitch system	--	10 hours of operation/ daily
Clean bolt guide	G	50 hours of operation/ weekly
Clean the bolt contact surface	H	50 hours of operation/ weekly
Clean bottom side of the quick coupler system	Y	50 hours of operation/ weekly
Clean contact surfaces of the attachment	K	50 hours of operation/ weekly
Clean the opening for the socket wrench and bores of the attachment support	L	50 hours of operation/ weekly
Clean bolt attachment support	M	50 hours of operation/ weekly

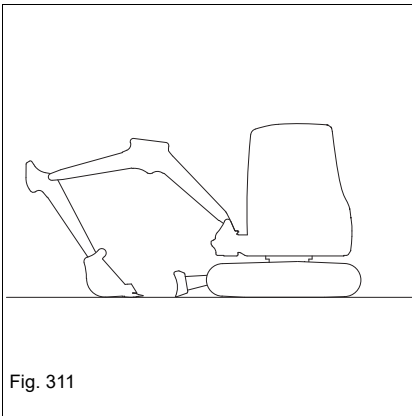
1. For time specifications: the first achieved time specification is decisive. If the situation requires it, perform maintenance if necessary, even if the maintenance interval has not yet been reached.

**Other maintenance intervals (Wacker Neuson service center):**

- Every 250 hours of operation or half-yearly
- Every 500 operating hours or annually

For additional details, contact a Wacker Neuson service center.

## Preparing lubrication



1. Stop the vehicle on firm, level, and horizontal ground.
2. Position the boom straight ahead at the center of the vehicle.
3. Lower the boom and the stabilizer legs to the ground.
4. Stop the engine.
5. Operate the control lever repeatedly to release the pressure in the hydraulic system.
6. Raise the control lever base.
7. Remove the starting key and carry it with you.
8. Safely store all loose objects.
9. Close the windows and doors.
10. Close and lock all covers.
11. Attach a warning label to the control elements (for example “**Machine being serviced, do not start**”).

Wait at least 10 minutes after stopping the engine.



### Information

Keep all lubrication points clean and remove any escaping grease.

One-piece boom

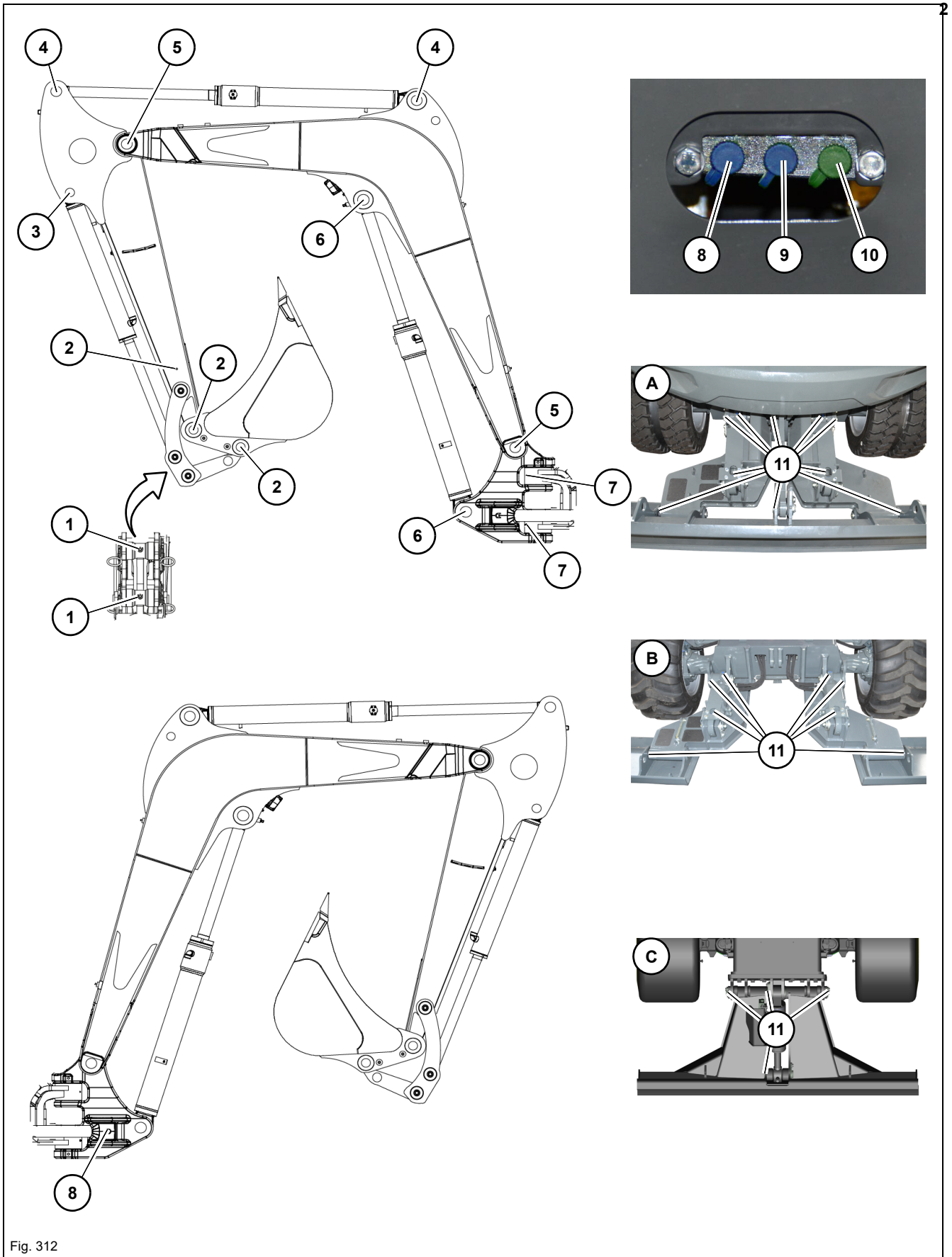


Fig. 312



Position	Lubrication point <sup>1</sup>	Interval	Quantity
1	3-pin pivot plate	Daily	2
2	Shovel arm	Daily	3
3	Bucket cylinder	Daily	1
4	Stick cylinder	Daily	2
5	Boom	Daily	2
6	Boom cylinder	Daily	2
7	Swiveling console	Daily	2
8	Swiveling cylinder	Daily	2
9	Live ring teeth (authorized service center)		1
10	Live ring (ball bearing) – see chapter “Live ring (ball bearing)” on page 7-17	Every week	1
11	<b>A</b> Parallel stabilizer blade	Daily	10
	<b>B</b> Stabilizer leg	Daily	8
	<b>C</b> Stabilizer blade	Daily	4

1. Lubrication on the pins or directly on the cylinders

Triple boom (option)

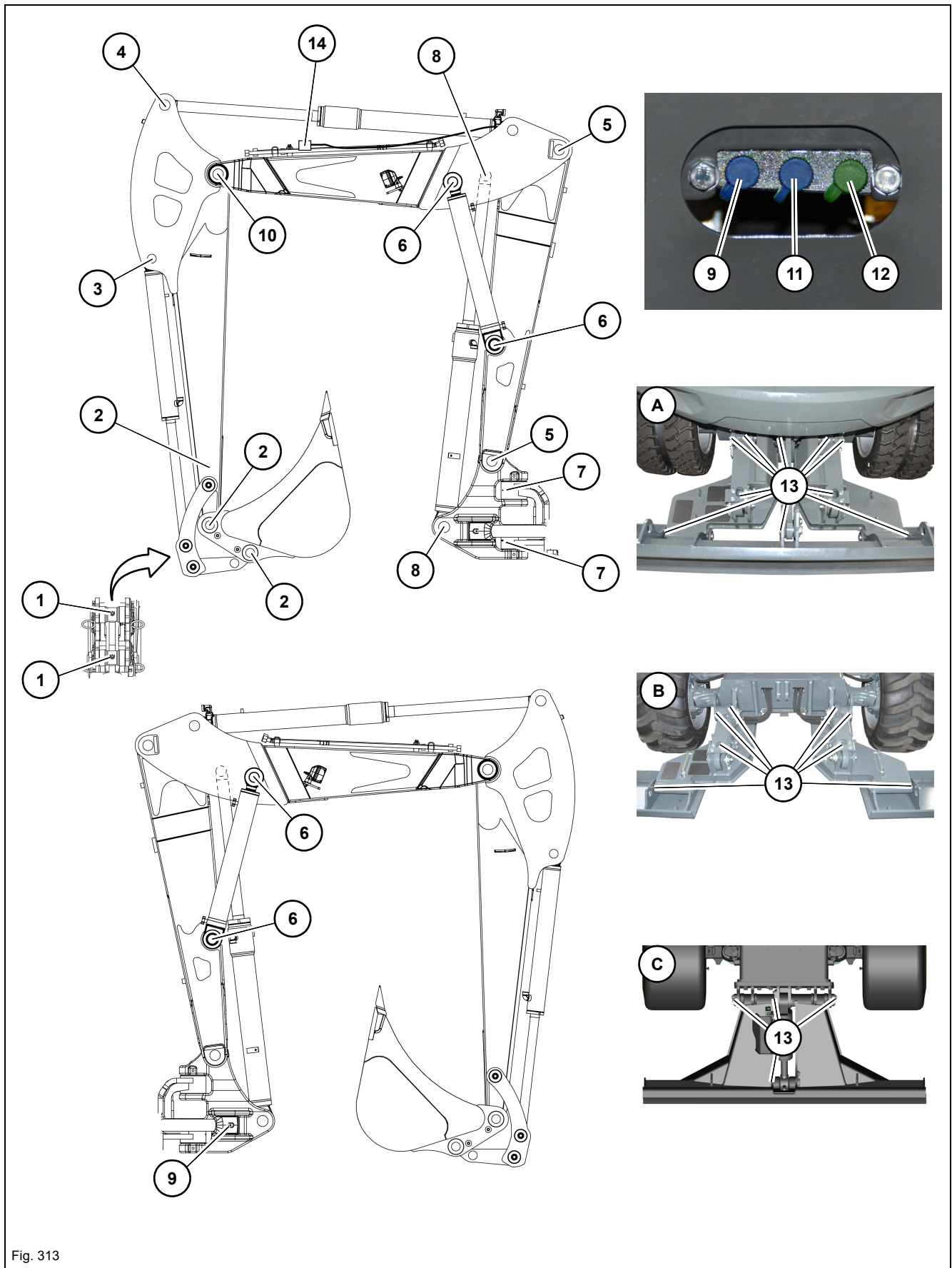


Fig. 313



Position	Lubrication point <sup>1</sup>	Interval	Quantity
1	3-pin pivot plate	Daily	2
2	Shovel arm	Daily	3
3	Bucket cylinder	Daily	1
4	Stick cylinder	Daily	1
5	Boom	Daily	2
6	Triple articulation boom cylinder	Daily	4
7	Swiveling console	Daily	2
8	Boom cylinder	Daily	2
9	Swiveling cylinder	Daily	2
10	Triple articulation boom	Daily	1
11	Teeth of live ring		1
12	Live ring (ball bearing) – see chapter “Live ring (ball bearing)” on page 7-17	Every week	1
13	<b>A</b> Parallel stabilizer blade	Daily	10
	<b>B</b> Stabilizer	Daily	8
	<b>C</b> Stabilizer blade	Daily	4
14	Remote lubrication point stick cylinder	Daily	1

1. Lubrication on the pins or directly on the cylinders

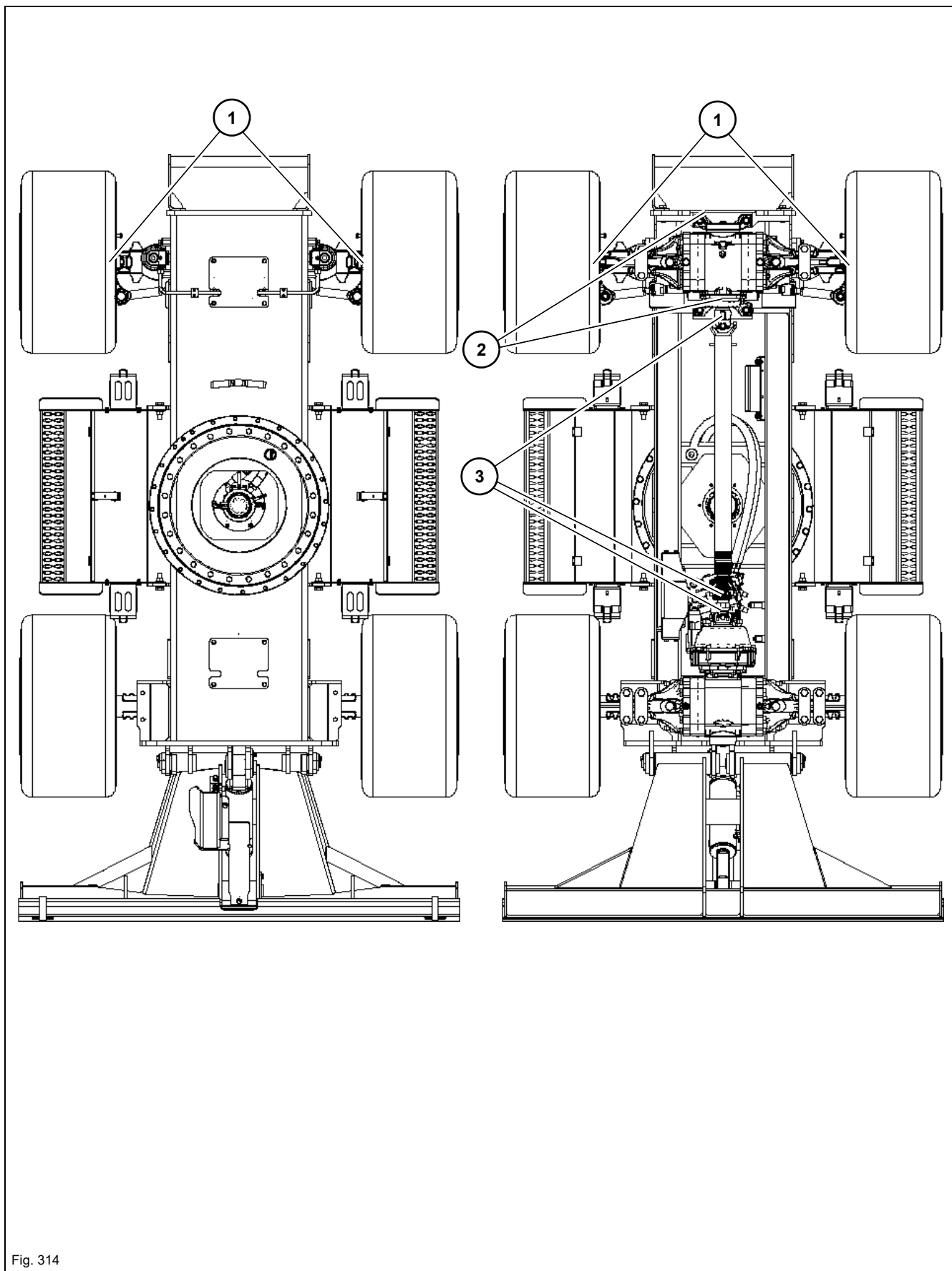


Fig. 314



<b>Position</b>	<b>Lubrication point</b>	<b>Interval</b>	<b>Quantity</b>
1	Upper and lower steering housing – <i>see chapter “Steering housing” on page 7-19</i>	Daily	4
2	Oscillating axle bearing mount – <i>see chapter “Oscillating axle bearing mount” on page 7-19</i>	Every week	2
3	Cardan shaft – <i>see chapter “Cardan shaft” on page 7-20</i>	500 o/h	3

Cabin/attachment mounts

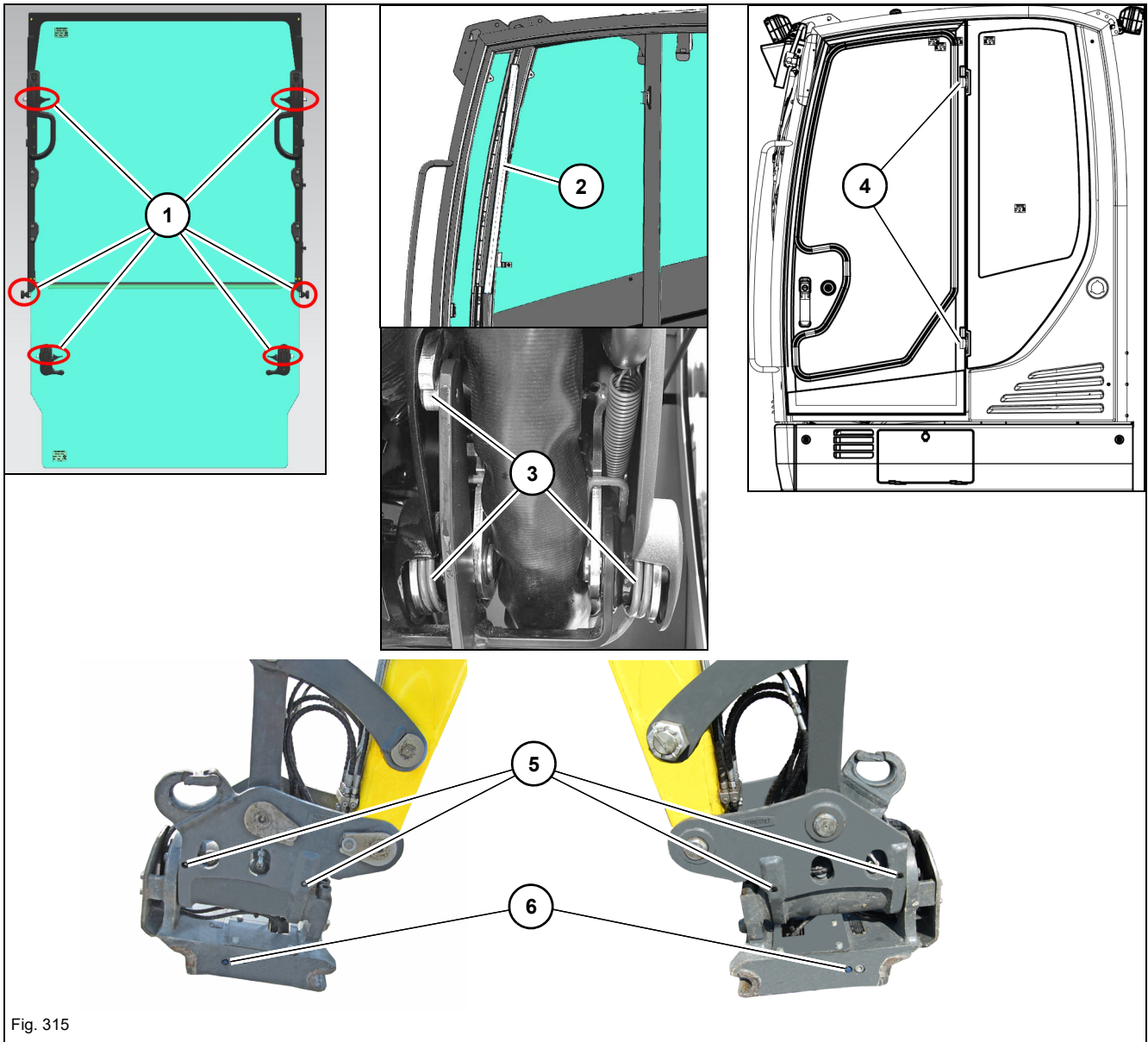


Fig. 315

Position	Lubrication point	Interval	Quantity
1	Front window: pin, lock notches and locks	Every week	6
2	Windshield: guide rails	Every week	2
3	Control lever base – see chapter “Control lever base” on page 7-18	Every week	3
4	Door hinges	Every week	2
5	Powertilt (option)	daily <sup>1;2</sup>	4
6	Hydraulic quickhitch (option)	daily/weekly <sup>1</sup>	2

1. Twice daily when used in water, after use in water apply grease, to remove all traces of water.  
 2. The number and position of the lubrication points could vary depending on the Powertilt model.

## Live ring (ball bearing)

### **DANGER**

#### **Crushing hazard during lubrication!**

Serious crushing hazard causing death or serious injury.

- ▶ No one must be in the danger zone during upper carriage rotation.

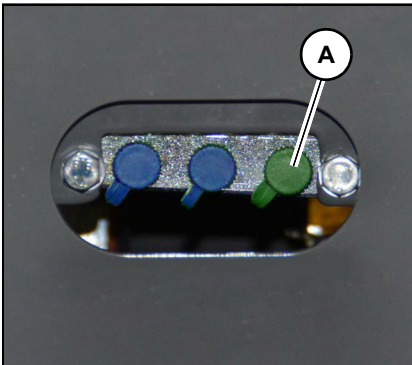


Fig. 316

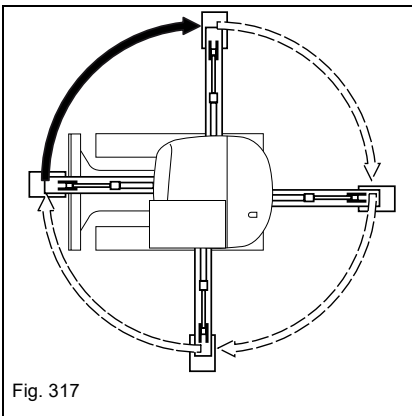


Fig. 317

The lubrication points are located on the right side of the upper carriage.

1. Park the vehicle on firm, level, and horizontal ground.
2. Lower the boom and the stabilizer blade to the ground.
3. Stop the engine, remove the starting key and carry it with you.
4. Apply grease to lubrication point **A** with two strokes of the grease gun.
5. Start the engine, raise the boom and the stabilizer blade.
6. Rotate the upper carriage by 90°.
7. Repeat steps 2–6 three times until the revolving upper carriage is back in its initial position.
8. Rotate the upper carriage several times by 360°.

## Control lever base

---

**!** **CAUTION**

Crushing hazard in the area of the moving parts of the control lever base!

Injury hazard due to crushing of parts of body.

► Stay clear (extremities, clothing) of the moving parts.

---

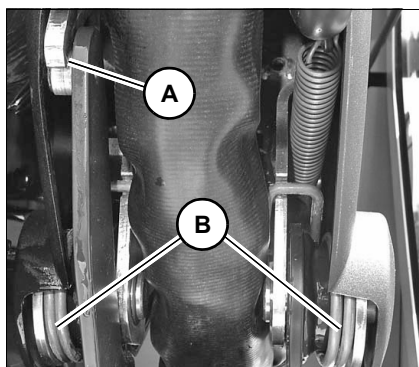


Fig. 318

1. Raise the control lever base.
2. Spray fluid grease onto the guide lever in the area of **A**.
3. Spray fluid grease on both sides **B** of the double spring.

## Oscillating-axle cylinder

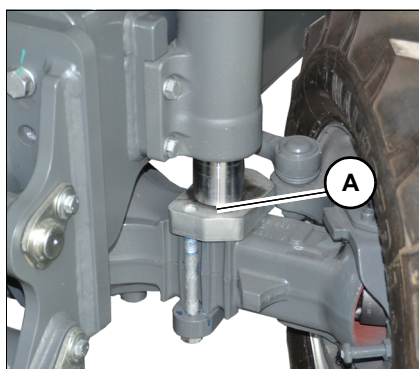


Fig. 319

---

**NOTICE**

Noise caused by friction at limit stops **A** on the left and right can be reduced with Wacker Neuson Anti Seize as required.

---

### Steering housing

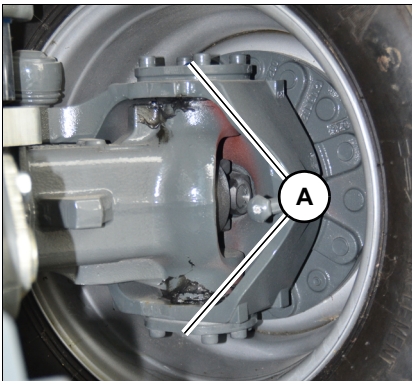


Fig. 320

Lubrication points **A** of the steering housing are located above and below on either side of the steering axle.

### Oscillating axle bearing mount

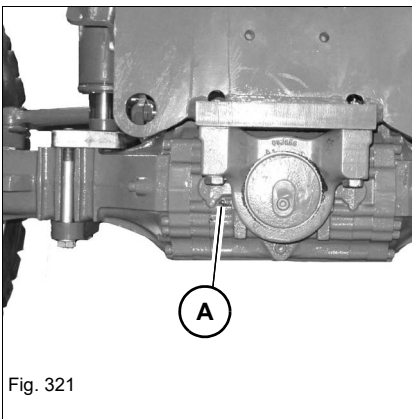


Fig. 321

Lubricate lubrication points **A** and **B** of the oscillating axle bearing mounts.

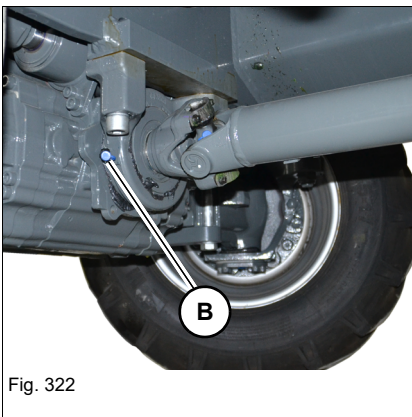


Fig. 322

## Cardan shaft

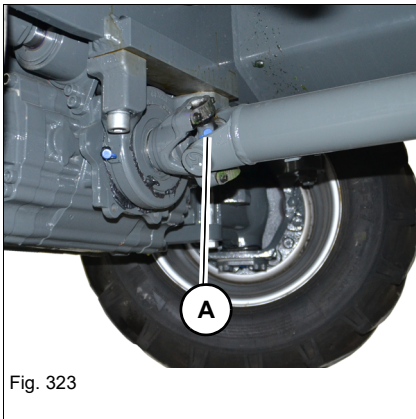


Fig. 323

Lubrication point **A** is located at the front end of the cardan shaft.  
Lubrication points **B** are located at the rear end of the cardan shaft.

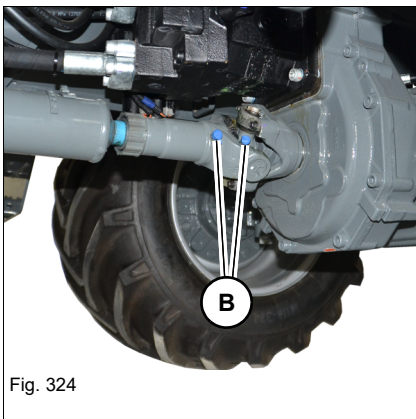


Fig. 324

## Powertilt with Easy Lock – operation in water

- Apply grease to the lubrication points before using in water.
- After using in water, apply grease to the lubrication points to remove all water.

## 7.3 Fluids and lubricants

### Consumables

Application	Fluid/lubricant	Specification	Season/temperature	Capacities <sup>1</sup>
Engine	Diesel fuel <sup>2</sup>	ASTM D975 grade 2D S15 (USA) <sup>3</sup>	Year-round <sup>4</sup>	85 liters (22.5 gal)
		EN 590 (EU) <sup>5</sup>		
		BS 2869:2010 class A2 (GB) <sup>6</sup>		
Engine	Coolant <sup>7</sup>	Distilled or deionized water and ASTM D6210	Year-round	10.5 liters (2.8 gal) <sup>8</sup>
				12 liters (3.2 gal) <sup>9</sup>
				11.6 liters (3.1 gal) <sup>10</sup>
Engine (404D)	Engine oil <sup>11</sup>	API CH-4; ACEA E5; EMA-DHD-1	-15°C (+5°F) +45°C (+113°F)	8.9 liters (2.4 gal)
Engine (404F)		API CJ-4; ACEA E9; ECF-3		8.6 liters (2.3 gal)
Engine (404J)				8.9 - 10.6 Liter (2.4 - 2.8 gal)
Hydraulic oil reservoir	Hydraulic oil	Eurolob HVLP 46 <sup>12</sup>	Year-round <sup>13</sup>	92 liters (24.3 gal)
	Biodegradable hydraulic oil <sup>14</sup>	Panolin HLP Synth 46		
		BP Biohyd SE-S 46		
Washer system	Cleaning agent	Glass cleaner and anti-freeze	Year-round	1 liters (0.3 gal)
Grease nipples	Grease	KPF 2 K-20 <sup>15</sup> ISO-L-X-BCEB 2 <sup>16</sup>	Year-round	As required
Battery terminals	Acid-proof grease <sup>17</sup>	FINA Marson L2	Year-round	As required
Control lever base	Adhesive fluid grease	Förch S401	Year-round	As required

- The capacities indicated are approximate values; the oil level check alone is relevant for the correct oil level.  
Capacities indicated are no system fills
- In regions without exhaust gas regulations the 404D-22T engine may be operated with a sulfur content of up to 0.4% (= 4000 ppm).
- Sulfur content up to 0.0015% (= 15 ppm)
- Summer or winter diesel depending on outside temperatures
- Sulfur content up to 0.0010% (= 10 ppm)
- Sulfur content up to 0.0010% (= 10 ppm)
- Factory filling; Do not mix coolant - observe the coolant compound table; Contact an authorized service center
- System fillings, including hoses and diesel engine 404D-22T and 404F-22T
- System fillings including hoses and diesel engine 404F-E22TA
- System fillings including hoses and diesel engine 404J-E22T
- According to DIN 51511 (API CJ-4, ACEA E9, ECF-3) – see chapter “Engine oil” on page 7-23
- According to DIN 51524 section 3, ISO-VG 46
- Depending on local conditions – see chapter “Hydraulic oil types” on page 7-22
- Biodegradable hydraulic oil based on saturated synthetic esters with an iodine value of < 10, according to DIN 51524, section 3, HVLP, HEES
- KPF 2 K-20 according to DIN 51502 lithium-saponified grease
- ISO-L-X-BCEB 2 according to DIN ISO 6743-9, lithium-saponified grease
- Standard acid-proof grease NGLI category 2



## Hydraulic oil types

Viscosity class	Ambient temperature			
	min. °C	min. °F	max. °C	max. °F
ISO VG32	-20	-4	30	86
ISO VG46	-5	23	40	104
ISO VG68	5	41	50	122

### Replacement intervals

Replace the hydraulic oil and hydraulic oil filter depending on the percentage of hammer operation.

Percentage of hammer work	Hydraulic oil	Hydraulic oil filter
20%	800 o/h	300 o/h
40%	400 o/h	
60%	300 o/h	100 o/h
Over 80%	200 o/h	

**Engine oil**
**Engine oil types (404D)**

Viscosity grade (SAE)	Ambient temperature			
	min. °C	min. °F	max. °C	max. °F
0W20	-40	-40	10	50
0W30	-40	-40	30	86
0W40	-40	-40	40	104
5W30	-30	-22	30	86
5W40	-30	-22	40	104
10W30	-20	-4	40	104
15W40	-10	14	50	122

**Engine oil types (404F-22T)**

Viscosity grade (SAE)	Ambient temperature			
	min. °C	min. °F	max. °C	max. °F
0W30	-30	-22	30	86
0W40	-30	-22	40	104
5W30	-25	-13	30	86
5W40	-25	-13	50	122
10W30	-18	0	40	104
10W40	-18	0	50	122
15W40	-10	14	50	122

**Engine oil types (404F-E22TA)**

Viscosity grade (SAE)	Ambient temperature			
	min. °C	min. °F	max. °C	max. °F
0W30	-35	-31	40	104
0W40	-35	-31	50	122
5W30	-30	-22	40	104
5W40	-30	-22	50	122
10W30	-25	13	40	104
10W40	-25	13	50	122
15W40	-20	4	50	122

**Engine oil types (404J-E22T)**

Viscosity grade (SAE)	Ambient temperature			
	min. °C	min. °F	max. °C	max. °F
0W30	-30	-22	40	104
0W40	-30	-22	40	122
5W30	-25	-13	30	86
5W40	-25	-13	50	122
10W30	-18	0	40	104
10W40	-18	0	50	122
15W40	-9	15	50	122

**Important information regarding operation with biodegradable hydraulic oil**

- Use only the biodegradable oils that have been tested and released by Wacker Neuson.
- Add only biodegradable oil of the same type. In order to avoid misunderstandings, attach a clear label to the hydraulic oil filler neck providing clear information regarding the type of oil currently used. The joint use of two different biodegradable oils can affect the quality of one of the oil types. Therefore ensure that the remaining amount of biodegradable oil complies with the national and regional regulations as you replace it. Observe the manufacturer's indications.
- Do not add mineral oil – the content of mineral oil should not exceed 2% of the system fill in order to avoid foaming problems and to ensure biological degradability.
- When running the vehicle with biodegradable oil, the same oil and filter replacement intervals are valid as for mineral oil.
- Always have the condensation water in the hydraulic oil reservoir drained by a Wacker Neuson service center before the cold season. The water content may not exceed 0.1% by weight.
- The instructions in this Operator's Manual concerning environmental protection are also valid for the use of biodegradable oil.
- Subsequent change from mineral oil to biodegradable oil may only be performed by a Wacker Neuson service center.



## 7.4 Maintenance accesses

---

 **WARNING**

**Injury hazard due to rotating parts!**

Rotating parts can cause serious injury or death.

- ▶ Open the engine cover only at engine standstill.
- 

 **CAUTION**

**Burn hazard due to hot surfaces!**

Can lead to severe burns or even death.

- ▶ Stop the engine and let hot surfaces cool down.
  - ▶ Wear protective equipment.
- 

 **CAUTION**

**Injury hazard due to open maintenance access!**

Can cause injury.

- ▶ Take care to avoid injuries when the maintenance access door is open.
-

## Opening the engine cover

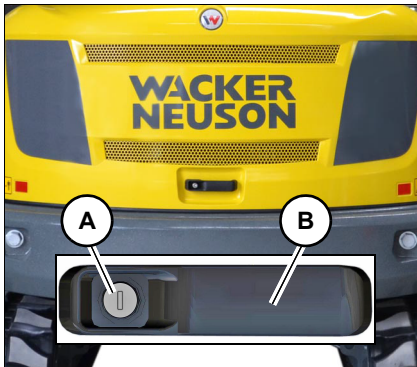


Fig. 325

1. Stop and park the vehicle. Stop the engine.  
- See "**Preparing lubrication**".
2. Turn the starting key in lock **A** anticlockwise.
3. Press lock **A** and pull handle **B**.

The engine cover is supported by a gas strut with lock **C** (item 1).

## Closing the engine cover

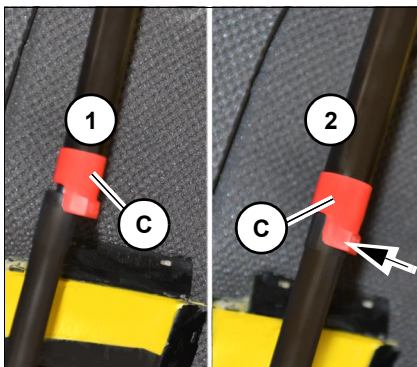


Fig. 326

1. Release lock **C** by applying slight pressure (position **2**).
2. Use handle **B** to pull engine cover downward slightly.
3. Pull handle **B** firmly downward until the engine cover engages.
4. Turn the starting key in lock **A** clockwise.

### Opening the valve cover

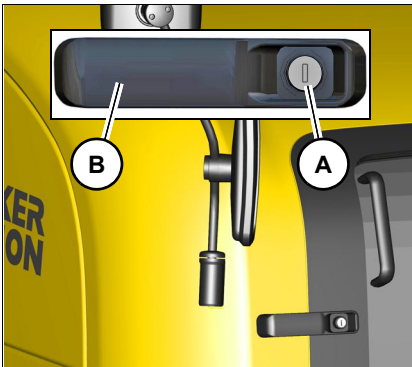


Fig. 327

1. Stop and park the vehicle. Stop the engine.  
- See “**Preparing lubrication**”.
  2. Turn the starting key in lock **A** anticlockwise.
  3. Press lock **A** and pull handle **B**.
- The engine cover is supported by a gas strut.

### Close the valve cover



Fig. 328

1. Pull valve cover down with fastening strap **C**.
2. Pull handle **B** firmly downward until the valve cover engages.
3. Turn the starting key in lock **A** clockwise.

### Fuse boxes

– see chapter “9.8 Electrical system” on page 9-5

## Maintenance flap

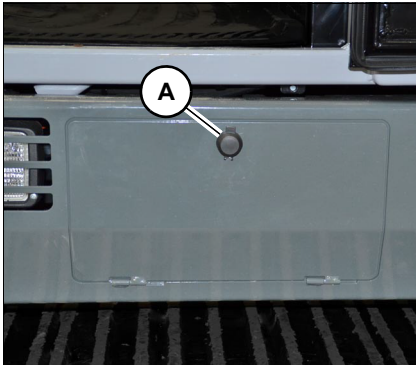


Fig. 329

The service flap is located at the left on the upper carriage. It contains:

- On-board tools
- Prop (for Wacker Neuson service center only)

### Unlocking:

Turn the starting key in lock **A** anticlockwise.

### Locking:

Turn the starting key in lock **A** clockwise.

## Cabin air filter

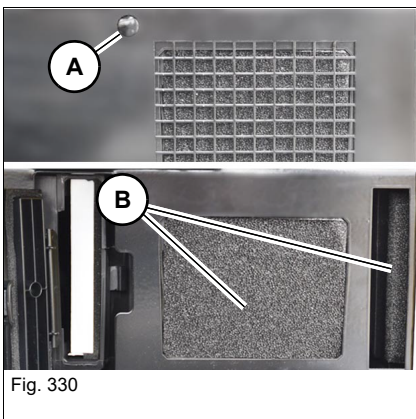


Fig. 330

1. Remove screw **A** and the cover.
2. Clean coarse filter **B** with compressed air daily.
3. Reinstall the cover and fasten it with screw **A**.



---

## 7.5 Cleaning and maintenance

---

 **WARNING**

**Injury hazard due to rotating parts!**

Rotating parts can cause serious injury or death.

- ▶ Open the engine cover only at engine standstill.

---

 **WARNING**

**Burn hazard due to hot surfaces!**

Hot surfaces can cause serious burns or death.

- ▶ Stop the engine and let it cool down.
- ▶ Wear protective equipment.

---

 **CAUTION**

**Health hazard due to cleaning agents!**

Cleaning agents can be harmful to health.

- ▶ Use only suitable cleaning agents.
- ▶ Ensure sufficient ventilation.

---

**NOTICE**

Damage to rubber and electrical parts when cleaning with solvents.

Do not use solvents, benzine, or other aggressive chemicals.

---

**NOTICE**

Damage to electronics due to water jet.

- ▶ Electronic components (e.g. relays, displays) must not be cleaned with a high-pressure cleaner.
  - ▶ Electric components (e.g. headlight, rotating beacons) must be at a distance of at least 50 cm (20 in) from the jet of the high-pressure cleaner.
  - ▶ Dry electric components carefully with compressed air and apply contact spray to them.
-



### **Environment**

In order to avoid damage to the environment, clean the vehicle only in wash bays and places authorized by the authorities.

Cleaning the vehicle is divided into three separate areas:

- Inside the cabin
- Exterior of the vehicle
- Engine compartment

### **Washing solvents**

- Ensure sufficient room ventilation.
- Wear suitable protective clothing.
- Do not use flammable liquids, such as gasoline or diesel.

### **Compressed air**

- Work carefully.
- Wear safety glasses and protective clothing.
- Do not aim the compressed air at the skin or at other people.
- Do not use compressed air for cleaning your clothing.

### **High-pressure cleaner**

- Cover electric parts.
- Do not point the water jet directly at electric parts and damping material.
- Cover the vent filter on the hydraulic oil reservoir and the filler caps for fuel, hydraulic oil, etc.
- Protect sensitive components from moisture:
  - Do not clean the engine compartment, engine components, electric components and damping material using a high-pressure cleaner.
  - Electrical components (for example alternator, control valves, connector plug at the wiring harness)
  - Control devices and seals
  - Air filter, exhaust etc.
  - Cover tank lock and filter
- Keep a safe distance from the labels.

**Volatile and easily flammable anti-corrosion agents and sprays:**

- Ensure sufficient room ventilation.
- Fire, open flames and smoking is prohibited.

**Inside the cabin**

## Recommended aids:

- Vacuum cleaner
- Moist cloths
- Brush
- Water with mild soap solution

**On the outside of the vehicle**

## Recommended aids:

- High-pressure cleaner
- Steam jet

**Engine compartment**

1. Park the vehicle in a wash bay or place suitable for washing.
2. Stop the engine. See **“Preparing lubrication”**.
3. Clean the vehicle.

**Seat belt**

Always keep the seat belt clean, as coarse dirt can impair the proper functioning of the seat belt buckle.

Clean the seat belt (while it remains fitted in the vehicle) with a mild soap solution only. Do not use chemical agents as they can destroy the fabric.

**Cleaning in a saline environment**

1. Park the vehicle in a wash bay or place.
2. See **“Preparing lubrication”**.
3. Check the vehicle for salt deposits or corrosion. Have corrosion removed by a Wacker Neuson service center.
4. Clean the vehicle with a high-pressure cleaner. Clean the vehicle ensuring that there are no salt deposits in places that are difficult to access.  
Bear in mind the information on cleaning and maintenance.
5. Lubricate the vehicle according to the lubrication plan.
6. Allow the vehicle to dry and check it again for salt deposits.

**Loose threaded fittings and attachments**

Contact a Wacker Neuson service center.

**7.6 Lubrication work**

– see chapter *“Preparing lubrication”* on page 7-9



### 7.7 Fuel system

#### Important information regarding the fuel system

**Information**

In order to prevent the formation of condensation water, fill up the fuel tank nearly completely at the end of each working day.

**Information**

Do not run the fuel tank completely dry. Otherwise, air is drawn into the fuel system. This requires bleeding the fuel system.

#### Diesel fuel specification

**NOTICE**

Engine damage due to incorrect or dirty diesel fuel.

- ▶ Only use clean diesel fuel according to the **lubricants** list.
- ▶ Do not use any diesel fuel with additives.

– see [“Fluids and lubricants” on page 7-21](#)

## Refueling

---

 **WARNING****Explosion hazard due to flammable fuel/air mixtures!**

Fuels develop explosive and flammable mixtures with air that can cause serious burns or death.

- ▶ Fire, open flames and smoking is prohibited.
  - ▶ Open tank lock carefully to release the pressure in the fuel tank.
  - ▶ Keep the maintenance area clean.
  - ▶ Do not refuel in closed rooms.
  - ▶ Do not add gasoline to diesel fuel.
  - ▶ Let the engine cool down.
- 

 **CAUTION****Health hazard due to diesel fuel!**

Diesel fuel and fuel vapors are harmful to health.

- ▶ Avoid contact with the skin, eyes and mouth.
  - ▶ Seek medical attention immediately in case of accidents with diesel fuel.
  - ▶ Wear protective equipment.
- 

 **CAUTION****Fire hazard due to diesel fuel!**

Diesel fuel gives off flammable vapors. This can cause injury.

- ▶ Fire, open flames and smoking is prohibited.
  - ▶ Adding gasoline is prohibited.
- 

 **CAUTION****Slipping/tripping hazard when refueling the vehicle!**

Can cause injury.

- ▶ Use safety-oriented ladders for refueling the vehicle.
  - ▶ Do not use vehicle parts or attachments as a climbing aid.
-

---

**NOTICE**

Do not refuel with cans in order to avoid dirt in the fuel.

---

**Refueling with a stationary fuel pump**

The fuel tank is located under the valve cover.

1. Stop the vehicle on firm, level, and horizontal ground.
2. Position the boom straight ahead at the center of the vehicle.
3. Lower the boom.
4. Stop the engine.
5. Raise the control lever base.
6. Open tank lock **C** carefully to release the pressure in the fuel tank.
7. Refuel the vehicle.
8. Close the tank lock **C**.

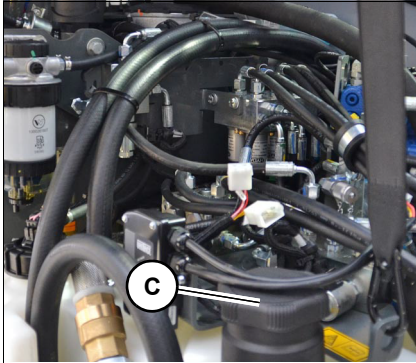


Fig. 331

---

**NOTICE**

Even the smallest particles of dirt can cause increased engine wear, malfunctions in the fuel system and reduced effectiveness of the fuel filters.

---

**Refueling from barrels**

- If refueling from barrels cannot be avoided, note the following points:
- Barrels must neither be rolled nor tilted before refueling.
- Protect the suction pipe opening of the barrel pump with a fine-mesh screen.
- Immerse the suction pipe opening down to a max. 15 cm (6 in) above the bottom of the barrel.
- Only fill the tank with filling aids (hopper or filling tube) with built-in filter.
- Keep all refueling containers clean.

## Refueling with a fuel-filling pump (option)

### CAUTION

**Injury hazard in case of incorrect handling of fuel-filling pump!**

Can cause injury.

- ▶ Keep body parts away from tank hoses.

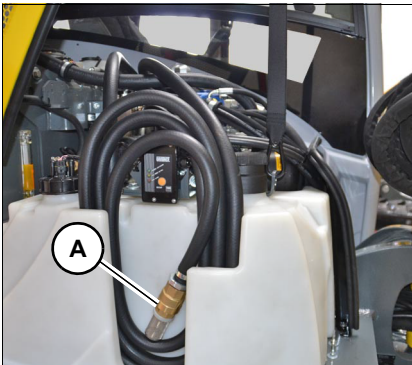


Fig. 332

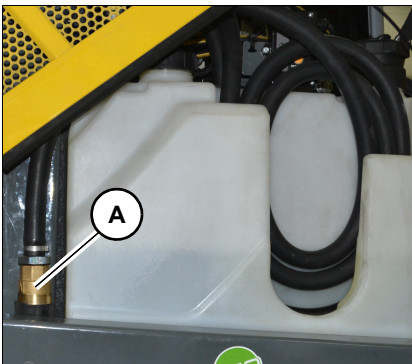


Fig. 333 (Version 2)

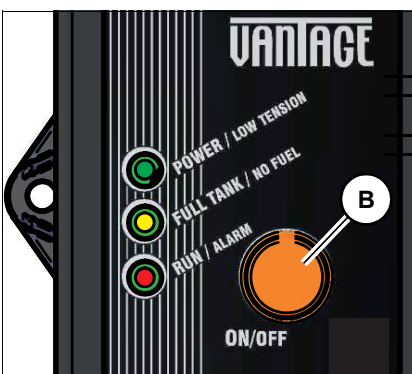


Fig. 334

### Refueling procedure

1. Stop the vehicle on firm, level, and horizontal ground.
2. Position the boom straight ahead at the center of the vehicle.
3. Lower the boom.
4. Stop the engine.
5. Raise the control lever base.
6. Open tank lock **C** carefully to release the pressure in the fuel tank.
7. Turn the starting key to position **1**.

8. Put hose **A** in the fuel tank.
9. Switch on the fuel-filling pump with push button **B**.
  - The green LED illuminates. The red LED illuminates, too, as soon as fuel is pumped by the pump.
  - Refueling stops automatically when the tank is full.
  - The green and yellow LEDs illuminate once refueling is over.
10. Switch off the fuel-filling pump with push button **B**.
11. Stow away hose **A**.
12. Close and lock filler cap **C**.

### Information

After one minute without actuation the pump automatically enters standby mode.



## Fuel-filling pump status indicators

LED			Status
Green	Yellow	Red	
<b>POWER</b>	<b>FULL TANK</b>	<b>RUN</b>	
On	On	On	Standby
Flashes	Off	Off	Voltage too low
On	Off	Off	Pump switched on
On	Off	On	Pump conveys fuel
On	Off	Flashes quickly	Contact a Wacker Neuson service center
On	Off	Flashes slowly	Contact a Wacker Neuson service center
On	On	Off	Refueling completed
On	Flashes	Off	Not enough fuel in the fuel hose (at the beginning of refueling)
			Not enough fuel in the barrel (at the end of refueling)
Flashes	Flashes	Off	Contact a Wacker Neuson service center
Off	Flashes	Flashes	Contact a Wacker Neuson service center

### Information

Refueling stops in the following cases:

- ▶ Push button **B** is pressed and held for a longer period.
- ▶ The maximum refueling time of 10 minutes was exceeded.
- ▶ Due to an error message or a full fuel tank.

## Fuel filter

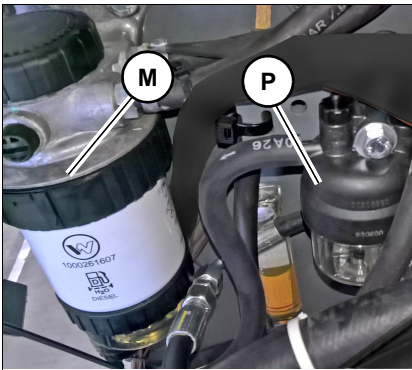


Fig. 335

The fuel prefilter **P** and fuel main filter **M** are located under the rocker cover.

Both are equipped with a water separator.

## Emptying the water separator (prefilter) (404F-E22TA)

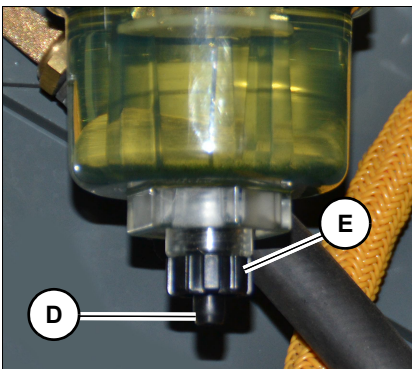


Fig. 336 (symbolic representation)

1. Stop and park the vehicle. Stop the engine. See “**Preparing lubrication**”.
2. Prepare a suitable container for collecting the fuel/water mixture.
3. Open the valve cover.
4. Connect a suitable hose to the drain device **D**.

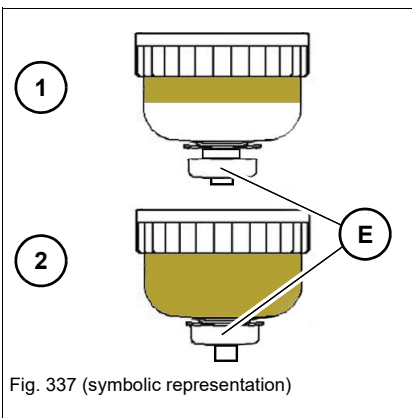


Fig. 337 (symbolic representation)

5. Open drain valve **E**.

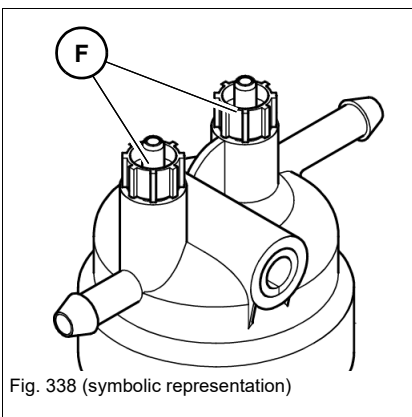


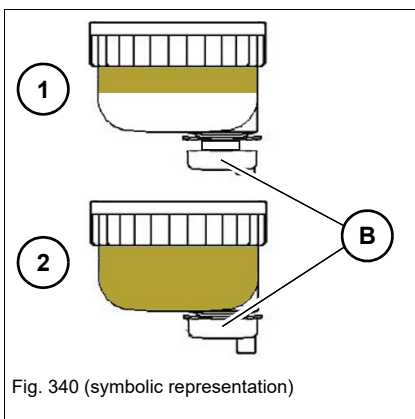
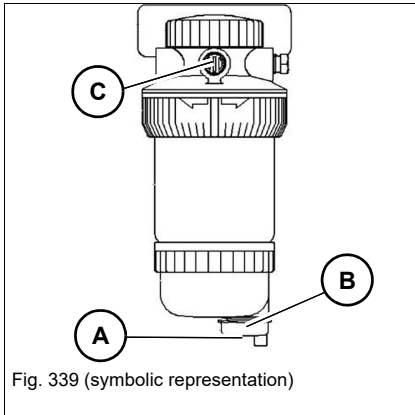
Fig. 338 (symbolic representation)

6. Vent screws **F**.
7. Drain the fuel/water mixture into a receptacle (1).
8. Tighten vent screws **F**.
9. Close drain valve **E** if nothing but fuel is visible in the sight glass (2).
10. Remove the hose.
11. Close and lock the valve cover.

## Empty the water separator (main filter)

### Information

Empty the water separator if the error message SPN 97 appears on the multi-functional display.



1. Stop and park the vehicle. Stop the engine. See “**Preparing lubrication**”.
2. Prepare a suitable container for collecting the fuel/water mixture.
3. Open the valve cover.
4. Connect a suitable hose to the drain device **A**.
5. Open drain valve **B**.
6. Loosen bleed screw **C**.
7. Drain the fuel/water mixture into a receptacle (1).
8. Tighten bleed screw **C**.
9. Close drain valve **B** if nothing but fuel is visible in the sight glass (2).
10. Remove the hose.
11. Close and lock the valve cover.

### Environment

Use a suitable container to collect fluids and lubricants as they flow out and dispose of them in an environmentally friendly manner.



## **Bleeding the fuel system**

Bleed the fuel system in the following cases:

- After removing and fitting the fuel filter, prefilter or the fuel lines back on again.
- If the machine is put into operation after having been decommissioned for more than 30 days.

Bleed the fuel system as follows:

1. Raise the control lever base.
2. Remove the starting key and carry it with you.
3. Fill up and close the fuel tank.
4. Turn the starting key to the first position.
5. Wait about five minutes while the fuel system bleeds itself automatically.
6. Start the engine.

If the engine runs smoothly for a while and then stops, or if it does not run smoothly:

1. Stop the engine.
2. Raise the control lever base.
3. Bleed the fuel system again as described above.
4. Check for leaks after starting the engine.
5. Have a Wacker Neuson service center perform a check if necessary.

---

## 7.8 Engine lubrication system

### Important information regarding the engine lubrication system

---

***NOTICE***

Possible engine damage due to incorrect engine oil level.

- ▶ The oil level must be between the MIN and MAX marks.
- 

***NOTICE***

Damage due to wrong engine oil.

- ▶ Use engine oil according to **Fluids and lubricants** list.
  - ▶ Have the oil changed only by a Wacker Neuson service center.
- 

***NOTICE***

Possible engine damage due to adding engine oil too quickly.

- ▶ Add the engine oil slowly so it can go down without entering the intake system.
- 

***NOTICE***

Damage due to contaminated engine oil.

- ▶ Make sure that no dirt gets into the openings when checking the engine oil level or filling up the engine oil.
-

## Checking the engine oil level

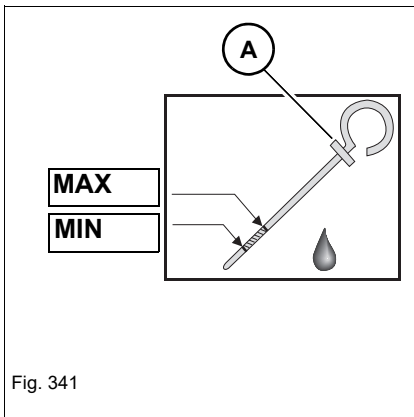


Fig. 341

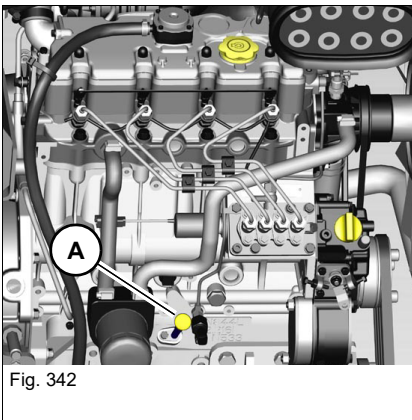


Fig. 342

1. Stop and park the vehicle. Stop the engine. See "Preparing lubrication".
2. Wait for at least 10 minutes, until the oil has run into the oil sump completely.
3. Open the engine cover.
4. Pull out oil dipstick **A** and clean it with a lint-free cloth.
5. Push oil dipstick **A** back in as far as possible.
6. Withdraw it and read off the oil level.
  - ➔ The oil level must be between the MIN and MAX marks.
  - ➔ Add engine oil if necessary.
7. Slide in oil dipstick **A** completely.
8. Close and lock the engine cover.

### Adding engine oil

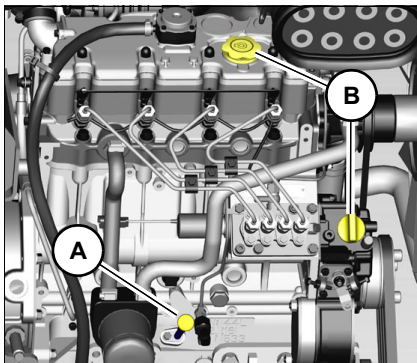


Fig. 343

1. Stop and park the vehicle. Stop the engine. See “Preparing lubrication”.
2. Wait for at least 10 minutes, until the oil has run into the oil sump completely.
3. Open the engine cover.
4. Open filler cap **B**.
5. Raise oil dipstick **A** slightly to allow any trapped air to escape.
6. Add engine oil.
7. Wait at least ten minutes.
8. Check the oil level.
9. Add oil if necessary and check the oil level again.
10. Close filler cap **B**.
11. Slide in oil dipstick **A** completely.
12. Close and lock the engine cover.

## 7.9 Cooling system

The radiators are located on the right in the engine compartment.

---

### **WARNING**

#### **Poisoning hazard due to hazardous substances!**

Contact with hazardous substances can cause serious injury or death.

- ▶ Wear protective equipment.
  - ▶ Do not inhale or swallow coolant.
  - ▶ Avoid contact of the coolant or antifreeze with the skin and eyes.
- 

---

### **WARNING**

#### **Burn hazard due to coolant or antifreeze!**

The coolant and antifreeze are easily flammable fluids that can cause serious burns or death if they are brought into contact with fire or open flames.

- ▶ Wear protective equipment.
  - ▶ Only perform maintenance on an engine that has cooled down.
  - ▶ Fire, open flames and smoking are prohibited.
- 

---

### **WARNING**

#### **Burn hazard due to hot coolant!**

At high temperatures, the cooling system is under pressure and can cause burning of the skin.

- ▶ Wear protective equipment.
  - ▶ Let the engine cool down.
  - ▶ Carefully open the radiator cap.
- 

---

### **NOTICE**

Possible engine damage due to wrong coolant.

- ▶ Observe the vehicle fluid, lubricants and coolant compound table.
- 

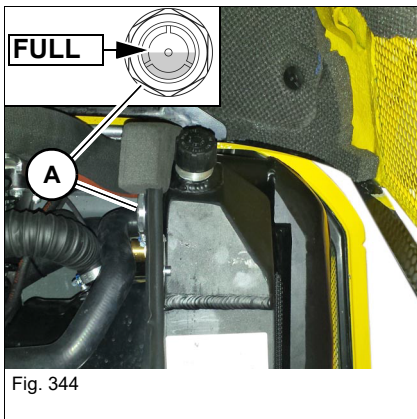
---

### **NOTICE**

Possible engine damage due to low coolant level.

- ▶ Check the coolant level once a day.
-

## Checking the coolant level



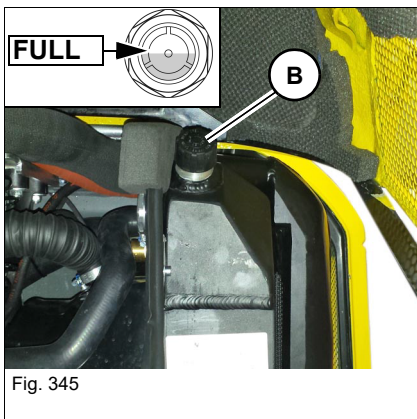
1. Stop and park the vehicle. Stop the engine. See "Preparing lubrication".
2. Open the engine cover.
3. Check the coolant level on sight glass **A**.
4. If the coolant level is below the **FULL** mark:
  - Add coolant.
5. Close and lock the engine cover.



### Information

Check the coolant level once a day before starting the engine.  
Observe the coolant compound table.

## Adding coolant



1. Stop and park the vehicle. Stop the engine. See "Preparing lubrication".
2. Open the engine cover.
3. Carefully unscrew filler cap **B** and release the pressure.
4. Open filler cap **B**.
5. Top off coolant up to the **FULL** mark.
6. Close filler cap **B**.
7. Start the engine and let it warm up for about 5–10 minutes.
8. Stop the engine.
9. Remove the starting key and carry it with you.
10. Let the engine cool down.
11. Check the coolant level again.
12. If necessary, add coolant and repeat the procedure until the coolant level remains constant.
13. Close and lock the engine cover.



### Information

Top off the coolant:

The flow rate for the coolant may be a maximum of 5 liters/min (1.3 gal/min) (404F-E22TA).

## Cleaning the radiator

---

 **CAUTION****Burn hazard due to hot surfaces!**

Hot radiators can cause burns.

- ▶ Stop the engine and let it cool down.
  - ▶ Wear protective equipment.
- 

**NOTICE**

Possible engine or hydraulic system damage due to dirt build-up at radiator fins.

- ▶ Check and if necessary clean the radiator once a day.
  - ▶ In dusty or dirty work conditions, clean more frequently than indicated in the maintenance plans.
- 

**NOTICE**

Possible damage to radiator fins during cleaning.

- ▶ Keep a safe distance from the radiator during cleaning.
  - ▶ Use oil-free compressed air (2 bar/29 psi max.) to clean.
- 

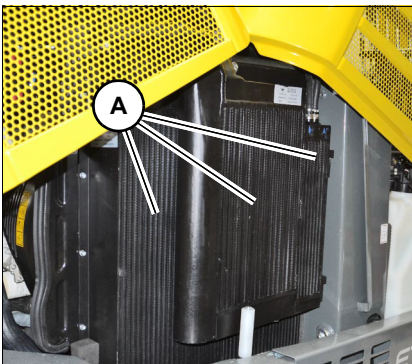


Fig. 346

Radiators **A** are located on the right in the engine compartment.

1. Stop and park the vehicle. Stop the engine. See “Preparing lubrication”.
2. Open the engine cover.
3. Remove dust and other foreign bodies from the fins with compressed air.
4. Close and lock the engine cover.

## 7.10 Air filter

### Checking the air intake

Have maintenance performed only by a Wacker Neuson service center.

#### **NOTICE**

Possible engine damage due to intake of dirty air.

► Check once a day before putting the vehicle into operation.

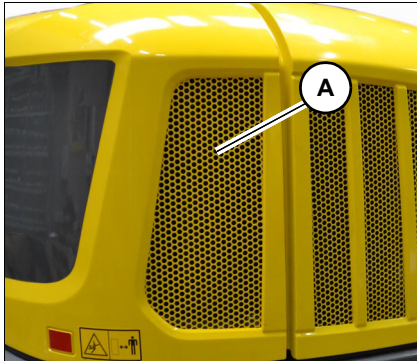


Fig. 347

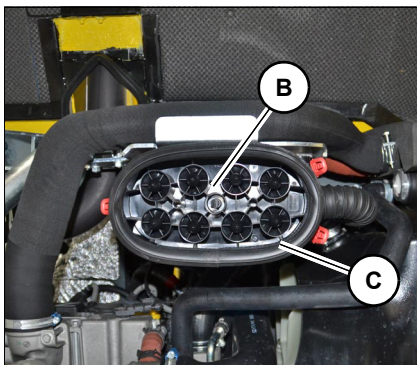


Fig. 348

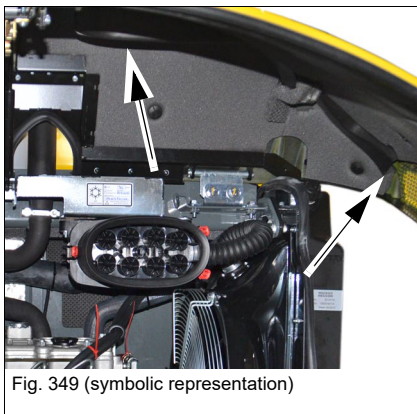


Fig. 349 (symbolic representation)

1. Stop and park the vehicle. Stop the engine. See "Preparing lubrication".
2. Remove the starting key and carry it with you.
3. Check and if necessary clean ventilation grill **A**.

4. Open the engine cover.
5. Check and if necessary clean air intake **B** at the air filter.
6. Check air filter seal **C** for damage and correct fit (only 404J-E22T). In case of damage or improper fit, contact an authorized workshop.

7. Check and if necessary clean air duct.
8. Close and lock the engine cover.



#### **Information**

The air duct is located laterally or in the rear depending on the engine version.

## 7.11 V-belt

V-belt tension may be checked and the V-belt re-tensioned only by a Wacker Neuson service center.

## 7.12 Hydraulic system

---

 **WARNING****Burn hazard due to hot hydraulic oil!**

Hot hydraulic oil can cause burning to the skin, serious injury or death.

- ▶ Release the pressure in the hydraulic system.
  - ▶ Let the engine cool down.
  - ▶ Wear protective equipment.
- 

---

 **WARNING****Injury hazard due to fluid escaping under pressure!**

Hydraulic oil escaping under pressure can penetrate the skin and cause serious injury or death.

- ▶ Do not operate the vehicle with leaking or damaged hydraulic system components.
  - ▶ Open the breather filter carefully to slowly release the pressure inside the reservoir.
  - ▶ Wear protective equipment. If hydraulic oil contacts the eye, flush immediately with clean water and seek medical treatment.
  - ▶ Malfunctioning or leaking screw connections, hose connections and pressure lines must be immediately repaired by a Wacker Neuson service center. Search for hydraulic leaks with a piece of cardboard.
- 

**NOTICE**

Damage due to wrong hydraulic oil.

- ▶ Only use hydraulic oil according to the **fluids and lubricants** list.
  - ▶ Have the hydraulic oil only changed by an authorized service center.
- 

**NOTICE**

Damage to hydraulic system due to incorrect hydraulic oil level.

- ▶ With a warm engine, the hydraulic oil must be about at the middle of the sight glass.
  - ▶ Check the hydraulic oil level once a day.
-

**NOTICE**

Possible damage to hydraulic system due to dirty hydraulic oil.

- ▶ Always add hydraulic oil using the filling screen.
- ▶ If the hydraulic oil in the sight glass is cloudy, this indicates that water or air has penetrated the hydraulic system. Contact a Wacker Neuson service center.
- ▶ Contact a Wacker Neuson service center if the filter of the hydraulic system is dirty.

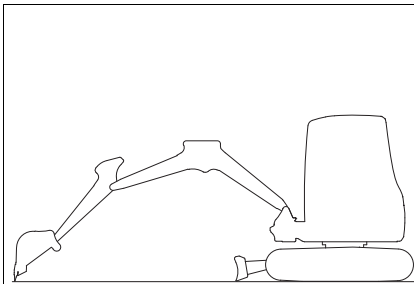
**Checking the hydraulic oil level**

Fig. 350 (symbolic representation)

1. Park the vehicle on firm, level, and horizontal ground.
2. Position the boom straight ahead at the center of the vehicle (see figure).
3. Lower the boom and the stabilizer blade to the ground.
4. Stop the engine.
5. Operate the control lever repeatedly to release the pressure in the hydraulic system.
6. Remove the starting key and carry it with you.

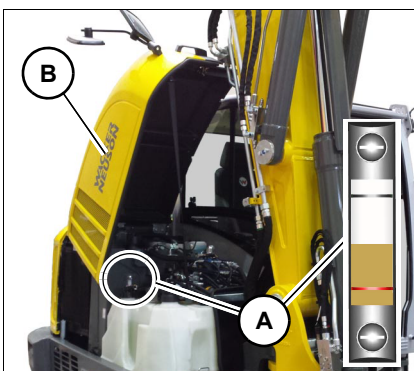


Fig. 351

7. Sight glass **A** is located underneath valve cover **B**.
8. Check the oil level on sight glass **A**.
  - ▶ If the engine is warm, the oil level must be approximately at the middle of sight glass **A**.
9. Add hydraulic oil if the oil level is below this mark.

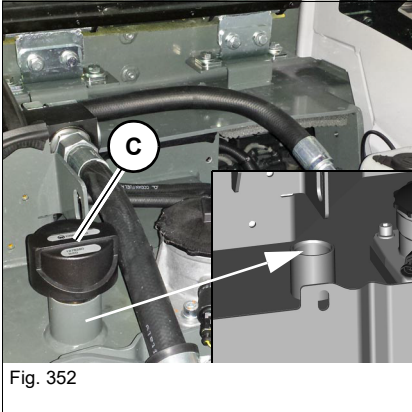
## Adding hydraulic oil

---

 **CAUTION****Slipping/tripping hazard when adding hydraulic oil!**

Can cause injury.

- ▶ Use a safety-oriented ladder to add hydraulic oil.
- ▶ Do not use vehicle parts or attachments as a climbing aid.



1. Open valve cover **B**.
2. Open breather filter **C** slowly to release the pressure inside the hydraulic oil reservoir.
3. Remove breather filter **C**.
4. Add hydraulic oil up to the corresponding mark.
5. Check the hydraulic oil level on sight glass **A**.
6. Add if necessary and check again.
7. Screw in breather filter **C** tightly.
8. Close and lock valve cover **B**.

**Environment**

Use a suitable container to collect fluids and lubricants as they flow out and dispose of them in an environmentally friendly manner.

---

## Checking the hydraulic system and hoses

Check the hydraulic system and hoses daily for leaks and general condition.

### **NOTICE**

Damage to the hydraulic system due to leaks and damaged hydraulic lines.

- ▶ Leaks and damaged hydraulic lines must be immediately repaired at an authorized service center. This increases the operating safety of the vehicle and contributes to environmental protection.
- ▶ Do not operate the vehicle with leaking or damaged hydraulic lines.

Hydraulic hoses are subject to natural aging. Therefore, they must be checked regularly, even when there is no visible damage, which prevents safe operation.

Wacker Neuson recommends following schedule for checks:

Normal wear	12 months
Increased wear (longer operation duration, multi-shift operation, high outside temperatures, aggressive environmental conditions etc.)	6 months

### **Responsibility of checking hydraulic hose**

The vehicle operator must decide the intervals at which the hydraulic hose has to be checked and the decision will be based on the actual work situation.

To do this, the vehicle operator must appoint a qualified person, who will check the hydraulic hoses. If there is noticeable damage, the hydraulic hose must be replaced immediately. Do not start the vehicle. The findings from this check must be retained in writing by the vehicle operator till the next scheduled check.



Wacker Neuson recommends replacing the hydraulic hoses every six years from the manufacturing date.

Manufacturing date can be found on the hydraulic hose.

- Re-tighten leaking screw connections and hose connections only when the system is not under pressure. Release the pressure in the hydraulic system before working on lines under pressure.
- Do not weld or solder damaged or leaking pressure lines and screw connections, but have them replaced.
- Wear protective equipment.

Have a line replaced immediately if one of the following problems is detected:

- Damaged or leaky hydraulic seals.
- Worn or torn shells or uncovered reinforcement branches.
- Expanded shells in several positions.
- Entangled or crushed movable parts.
- Foreign bodies jammed or stuck in protective layers.

### 7.13 Electrical system

#### Important information regarding the electrical system

Maintenance and repair work on the electrical system may be performed only by a Wacker Neuson service center!

- Malfunctioning parts of the electrical system must be replaced by an authorized service center.
- Light bulbs and fuses may be replaced by the operator.

#### Alternator

- Contact a Wacker Neuson service center if the alternator charge indicator light is malfunctioning.



#### **WARNING**

##### **Injury hazard due to malfunctioning batteries!**

Batteries give off explosive gases that can cause deflagrations if ignited.

- ▶ Wear protective equipment.
- ▶ Fire, open flames and smoking is prohibited.
- ▶ Do not jump start the engine if the battery is malfunctioning or frozen, or if the acid level is too low.
- ▶ Do not place conductive articles on the battery – risk of short circuit.

---

#### **NOTICE**

Possible damage to electrical components or engine electronics.

- ▶ Do not place conductive articles on the battery – risk of short circuit.
- ▶ Do not interrupt voltage-carrying circuits at the battery terminals because of the sparking hazard.
- ▶ Do not disconnect the battery while the engine is running.



#### **Environment**

Dispose of old batteries in an environmentally friendly manner.

---

## Fuses and relays

– see chapter “9.8 Electrical system” on page 9-5

## Battery

The battery may be checked, disconnected, charged and replaced only by a Wacker Neuson service center.

## 7.14 Heating, ventilation and air conditioning system

### Checking/changing the cabin air filter

Have maintenance performed only by a Wacker Neuson service center.

### 7.15 Washer system

Only use glass cleaner (with antifreeze if necessary) for refilling.

### Checking the fluid level and adding fluid

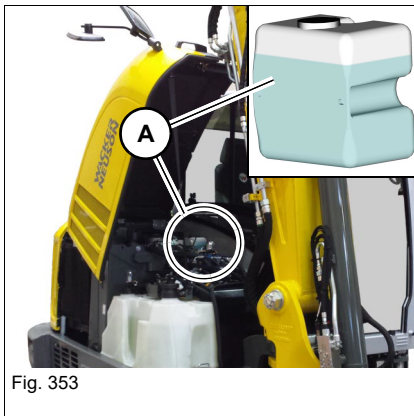


#### **CAUTION**

##### **Burn hazard due to hot surfaces!**

Can lead to severe burns or even death.

- ▶ Stop the engine and let it cool down.
- ▶ Wear protective equipment.



Reservoir filler inlet **A** is located on the right under the valve cover.

1. Stop and park the vehicle. Stop the engine. See “**Preparing lubrication**”.
2. Open the valve cover.
3. Check the fluid level in tank **A** and add fluid if necessary.
4. Close and lock the valve cover.

### 7.16 Axles/traveling drive

Have maintenance performed only by a Wacker Neuson service center.

### 7.17 Braking system

Have maintenance performed only by a Wacker Neuson service center.



### 7.18 Tires

---

 **WARNING**

**Accident hazard due to incorrect maintenance!**

Can cause serious injury or death.

- ▶ Have repair work on tires and rims performed only by a Wacker Neuson service center.
- ▶ Use suitable assembly tools, for example covering sleeves for the studs, and a jack.

---

 **Information**

Tire wear can vary according to work and ground conditions. Therefore interchange the tires regularly to ensure identical rolling properties.

---

 **Information**

Replace the tires after 6 years and dispose of them correctly since the properties of the rubber mixture degrade with increasing age.

---

 **Information**

If a damaged tire has to be replaced, then also replace all the tires on the same axle.

Use the machine only with intact tires and rims.

---

### Types of tires



- A:** Individual tires 300
- B:** Individual tires 425 (Option)
- C:** Dual tires (option)

---

**i** **Information**

Only use approved tires and rims – *see chapter “9.5 Tires” on page 9-4.*

---

Fig. 354



### Inspection work

Checking the tires at regular intervals increases operational safety and the service life of the tires, and reduces machine downtimes.

Perform the following maintenance once a day:

- Visual check of wheel condition.
- Check the tire pressure.
- Check the tires and rims (outside and inside) for damage and wear.
- Check the wheel nuts for tightness.
- Remove foreign bodies from the tire tread.
- Remove dirt, debris, dust, etc. from the tires.

## Wheel change

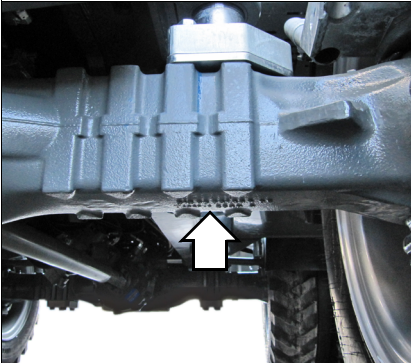


Fig. 355 (symbolic representation)

### Removing

1. Park the vehicle on firm, level, and horizontal ground.
2. Apply the parking brake.
3. Lock the service brake.
4. Use wheel chocks to prevent the machine from rolling away.
5. Loosen the wheel nuts of the wheel you want to remove.
6. Place a jack with a minimum lift capacity of 8000 kg (17,637 lbs) under the axle ensuring stability.
7. Raise the side of the axle from which you want to remove the wheel.
8. Check the machine is standing firmly.
9. Secure the machine with trestles in appropriate places.



### Information

Trestles must be positioned so as to avoid machine damage.

10. Completely remove the wheel nuts.
11. Remove the wheel.

### Assembly

1. Place the new wheel onto the wheel bolts.
  - ➔ Bear in mind the correct direction of rotation of the tires.
2. Tighten the wheel nuts.
  - ➔ Tighten the opposite wheel nut alternately.
3. Remove the trestles.
4. Lower the raised side of the machine.
5. Tighten the opposite wheel nuts alternately to the torque 270 Nm (199 ft.lbs).

After changing a wheel, check the wheel nuts for tightness after ten operating hours. Retighten the wheel nuts if necessary.



### 7.19 Maintenance of attachments

#### Important information regarding maintenance and care of attachments

Correct maintenance and service is absolutely necessary for smooth and continuous operation, and for an increased service life of the attachments. Please observe the lubrication and maintenance instructions in the Operator's Manuals of the attachments.

### 7.20 Maintenance of options

Have a Wacker Neuson service center check all eyes regularly:

- Machine lifting eyes
- Attachment lifting eyes
- Attachment load hooks
- Tie-down points
- Towing eyes

Have eyes or load hooks with inadmissible wear, a defective spring mechanism, etc. immediately replaced by a Wacker Neuson service center.

## 7.21 Exhaust gas cleaning (404F-22T)

The 404F-22T engine is fitted with a diesel particulate filter.

The soot produced by burning diesel fuel is collected and burned in the diesel particulate filter at regular intervals. This process is called regeneration.

Regeneration takes about 30 minutes.

The more often the automatic regeneration mode is corrected or modified, the longer regeneration takes.

If the dirt in the diesel particulate filter reaches a critical value, engine power is reduced and vehicle operation has to be stopped.

Regeneration is performed only if the engine is at operating temperature.



### **WARNING**

#### **Health hazard due to exhaust gases!**

Can cause serious health hazards or death.

- ▶ Do not inhale exhaust gases.
- ▶ Use only exhaust-gas suction systems suitable for exhaust-gas temperatures of up to 600°C (1112°F).
- ▶ Provide for sufficient ventilation when operating in enclosed areas.



### **WARNING**

#### **Burn hazard at the exhaust system!**

During regeneration, the exhaust system can develop exhaust-gas temperatures of about 600°C (1112°F), even if the engine is running at idling speed which can cause serious burns or death.

- ▶ Keep a safe distance from the exhaust system.



### **WARNING**

#### **Fire hazard during regeneration!**

Hot exhaust gases in easily flammable surroundings can cause serious injury or death.

- ▶ In environments with easily flammable material, disable the **automatic regeneration** mode.
  - ▶ Do not perform manual regeneration in environments with easily flammable material.
  - ▶ Use only exhaust-gas suction systems suitable for exhaust-gas temperatures of up to 600°C (1112°F).
-



---

### **NOTICE**

Potential damage to engine and irreparable damage to diesel particulate filter.

- ▶ Only use clean diesel fuel according to the **fluids and lubricants** list. Do not use biodiesel.
  - ▶ Perform the regeneration as early as possible (or have someone do it for you).
  - ▶ Do not ignore the **highest load** indication.
- 

### **NOTICE**

Fire hazard at the exhaust system.

- ▶ There must be no easily flammable material in the direct vicinity of the exhaust system, in particular near the end pipe.
  - ▶ Do not perform regeneration in surroundings with easily flammable material.
  - ▶ In environments with easily flammable material, disable the **automatic regeneration** mode.
- 



### **Information**

The load is the contamination level of the diesel particulate filter. Among other things, this level depends on the load on the diesel engine:

- ▶ High engine load = low load.
  - ▶ Low engine load = high load.
-



**Information**

Wacker Neuson recommends not to influence the automatic regeneration system if possible. Should disabling or interrupting regeneration be necessary, perform it again as soon as possible.

This increases the service life of the diesel particulate filter and avoids unscheduled stops at the service center, for example with shorter engine-oil replacement intervals.

The diesel particulate filter is a wear part, as soot and ash particles cannot be completely removed for technical reasons.

---



**Information**

Disabling/canceling regeneration increases the contamination level in the particulate filter. It may result in the vehicle stopping and requiring service regeneration by an authorized service center.

---

## Measures for increasing intervals between regeneration

- Avoid frequent engine stop-starts.
- Bring engine up to operating temperature.
- Avoid operation under low-load conditions.
- Do not disable or cancel regeneration.
- Re-perform regeneration as soon as possible after being disabled/ canceled.
- Only use clean diesel fuel according to the **fluids and lubricants** list.

## Measures when operating at great heights

- At 800 m (2625 ft.) above sea level, the vehicle automatically switches into high-altitude mode. The maximum engine speed increases to 2400 rpm and the adjacent symbol appears during the starting process.
- Operate the vehicle permanently at maximum speed to avoid shorter DPF regeneration intervals.
- When the boundary of 800 m (2625 ft.) is exceeded while driving, stop the engine and start it again after two minutes; this allows the high-altitude mode to switch on.
- The Eco and Power modes cannot be switched to manually when driving in high-altitude mode.

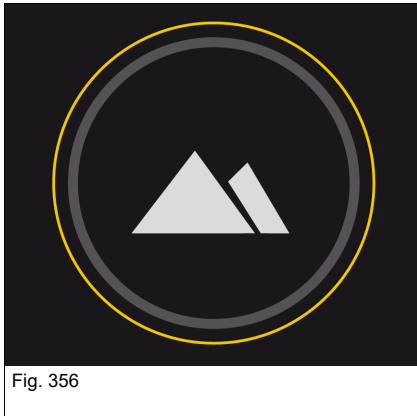


Fig. 356








### Information

The sea level of 800 m (2625 ft.) is a rough estimate and is affected by various environmental factors. The actual value may vary.

## Types of regeneration

Type	Description
Automatic regeneration	Is automatically performed by engine; work may be performed with the vehicle
Manual regeneration	Is started by driver; work may be performed with the vehicle
Service regeneration	May be performed only by an authorized service center

**Indicator lights**

Letter	Indication	Description
D		<b>Regeneration required/enabled</b> Illuminates when regeneration is required or during a regeneration
E		<b>Regeneration disabled/interrupted</b>
F		<b>Increased exhaust-gas temperature</b> Illuminates during regeneration or after regeneration, so long as the exhaust temperature is raised.
G		<b>Engine warning</b>
H		<b>Engine stop</b>


**Information**

The arrangement of the indicator lights may deviate depending on vehicle equipment.

## Indication of load condition

Level	Indication	Description/measure
1		<b>No load</b>
2		<b>Low load</b> Warm up the vehicle to operating temperature and perform automatic regeneration.
3		<b>Medium load</b> Warm up the vehicle to operating temperature and perform automatic regeneration. As required, perform a manual regeneration if an automatic regeneration was interrupted.
4		<b>Highest load</b> Perform manual regeneration. Do not turn off engine during regeneration.  If the load does not change, contact an authorized service center.
5		<b>Highest load exceeded</b> Stop the vehicle and contact a Wacker Neuson service center.

### Remarks:

- The indicator lights may illuminate or flash quickly and be in different positions depending on vehicle equipment.
- The engine warning **and** engine stop **indicator lights** may also illuminate if another fault occurs. This does not depend on the current load.
- If the regeneration button is held for 10 seconds, the symbol **Increased exhaust-gas temperature** will appear on the display.

## Control elements

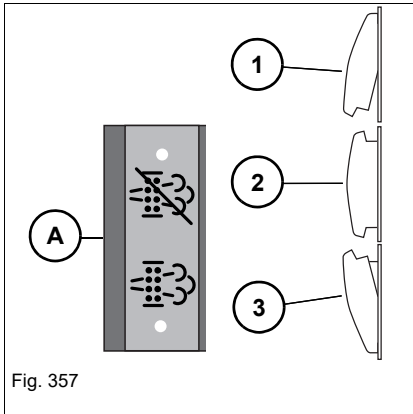
### Regeneration push button

The push button **A** is in the middle position and can be pressed in either direction, but does not lock into place.

The **automatic regeneration** mode is preset if the engine is stopped for at least 30 seconds.

Push button functions:

- 1: Disable/interrupt/re-enable regeneration
- 2: **Automatic regeneration** mode (middle position)
- 3: start manual regeneration



### Automatic regeneration mode

Indicator lights **D** and **F** illuminate during regeneration.

To disable the **automatic regeneration** mode:

Press and hold the touch button at least 3 seconds in position **1**.

➤ Indicator light **E** illuminates.

To re-enable the **automatic regeneration** mode:

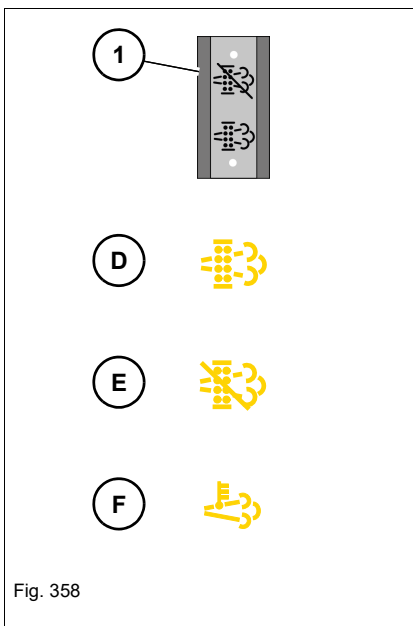
Press and hold the touch button at least 3 seconds in position **1**.

➤ Indicator light **E** does not illuminate.

To interrupt automatic regeneration:

Press and hold the touch button at least 3 seconds in position **1**.

➤ Indicator light **E** illuminates.



## Manual regeneration

The indicator light **D** lights up.

### Information

To be able to start a regeneration, the coolant temperature must be at least 70°C/158°F.

The indicator light **G** can blink depending on the loading condition.

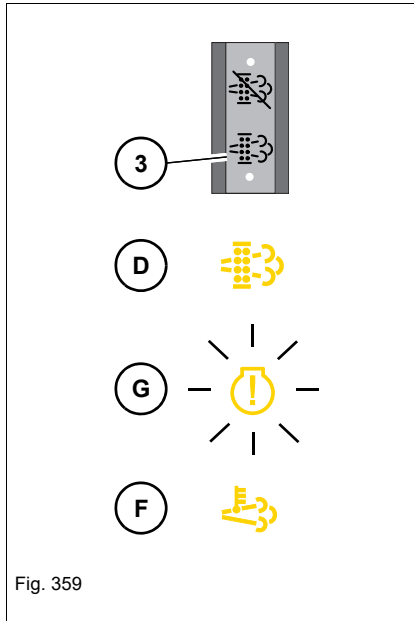


Fig. 359

### Starting manual regeneration

1. Drive the vehicle out of the danger zone and into a safe area.
2. Press and hold the **Regeneration** touch button at least 10 seconds in position **3**.

➔ Indicator lights **D** and **F** illuminate during regeneration.

### Information

Manual regeneration has the following effects on vehicle operation:

- ▶ Work may be performed with the vehicle.

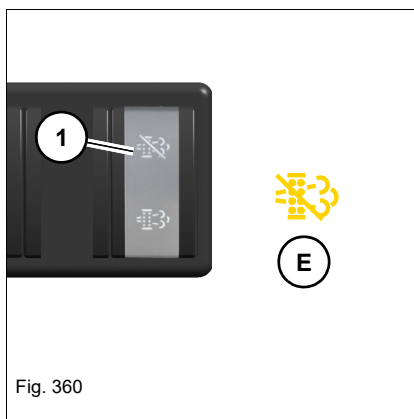


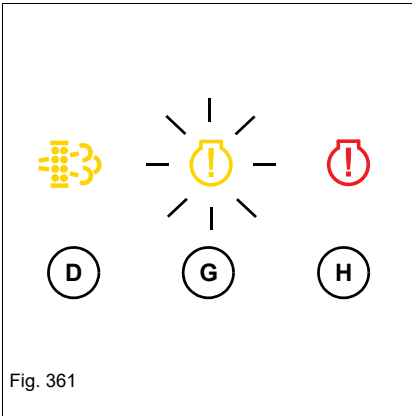
Fig. 360

### Interrupting manual regeneration

Press the touch button **Regeneration** in position **1** until indicator light **E** illuminates.

### Loading position 5 – parking the vehicle

The indicator lights **D** and **H** illuminate and the indicator light **G** blinks.  
Stop the engine immediately and contact a Wacker Neuson service center.



## 7.22 Exhaust gas cleaning (404J-E22T)

The 404J-E22T engine is fitted with a diesel particulate filter.

The soot produced by burning diesel fuel is collected and burned in the diesel particulate filter at regular intervals. This process is called regeneration.

Regeneration takes about 40 minutes.

If the dirt in the diesel particulate filter reaches a critical value, engine power is reduced and vehicle operation has to be stopped.

Regeneration is performed only if the engine is at operating temperature.



### **WARNING**

#### **Health hazard due to exhaust gases!**

Can cause serious health hazards or death.

- ▶ Do not inhale exhaust gases.
- ▶ Under pressure, the exhaust temperature can be up to 600°C (1112°F). Only use suitable exhaust-gas suction systems.
- ▶ Provide for sufficient ventilation when operating in enclosed areas.



### **WARNING**

#### **Burn hazard at the exhaust system!**

During regeneration, the exhaust system can develop exhaust temperatures of up to 350°C (662°F), even if the engine is running at idling speed, which can cause serious burns or death.

- ▶ Keep a safe distance from the exhaust system.



### **WARNING**

#### **Fire hazard during regeneration!**

Hot exhaust gases in easily flammable surroundings can cause serious injury or death.

- ▶ Under pressure, the exhaust temperature can be up to 600°C (1112°F). Only use suitable exhaust-gas suction systems.
  - ▶ Provide for sufficient ventilation when operating in enclosed areas.
-



---

**NOTICE**

Potential damage to engine and irreparable damage to diesel particulate filter.

- ▶ Only use clean diesel fuel according to the **fluids and lubricants** list. Do not use biodiesel.
  - ▶ Avoid regular operation when the engine is cold.
  - ▶ Do not ignore indicator lights.
  - ▶ Do not cancel regeneration.
- 

---

**NOTICE**

Fire hazard at the exhaust system.

- ▶ There must be no easily flammable material in the direct vicinity of the exhaust system, in particular near the end pipe.
- 



**Information**

The load is the contamination level of the diesel particulate filter. Among other things, this level depends on the load on the diesel engine.

---



**Information**

Wacker Neuson recommends not to influence the automatic regeneration system if possible. This avoids unscheduled visits to the service center.

---

**Information**

Do not fold down the joystick base during regeneration. This interrupts the regeneration. After successful regeneration, the indicator lights go out and the engine goes to idling speed.

**Information**

Interrupting a regeneration increases the contamination level in the particulate filter. It may result in the vehicle stopping and requiring service regeneration by an authorized service center.




**Measures for increasing intervals between regeneration**

- Bring engine up to operating temperature.
- Avoid operation under low-load conditions.
- As soon as the indicator light for **regeneration required** lights up, the system is not in the normal state anymore. The operator has to support regeneration actively.
- Only use clean diesel fuel according to the **fluids and lubricants** list.

**Types of regeneration**

Type	Description
Automatic regeneration (Escalation level 1)	<b>There is no fault in the system</b> The system carries out automatic regeneration in the background.
Automatic regeneration/ Standstill regeneration (Escalation level 2)	<b>There is a fault in the system</b> The operator has to facilitate regeneration: <ul style="list-style-type: none"> <li>• Work with the vehicle. When that is not possible, fold up the joystick base, press the parking brake and run the engine.</li> </ul>
Standstill regeneration (Escalation level 3)	<b>There is a serious fault in the system</b> The operator has to facilitate regeneration: <ul style="list-style-type: none"> <li>• Raise the control lever base, apply parking brake and let the engine run.</li> </ul>
Service regeneration	May be performed only by an authorized service center.

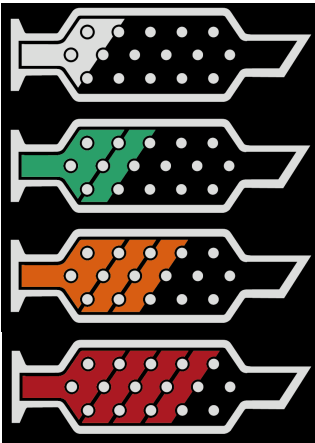
**Indicator lights**

Letter	Indication	Description
(D)		<b>Regeneration required</b> <ul style="list-style-type: none"> <li>Lights up immediately, when there is a fault in the system</li> </ul>
(G)		<b>Engine warning</b> <ul style="list-style-type: none"> <li>Lights up immediately, when there is a serious fault in the system</li> </ul>
(H)		<b>Engine stop</b> <ul style="list-style-type: none"> <li>Lights up immediately, when there is an irreversible error in the system</li> </ul>

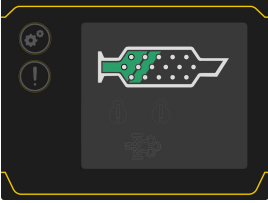
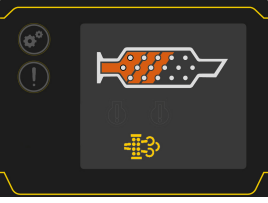
**Indication of the load condition**

**Information**

The load condition is shown only in the menu – **DPF-data**.  
Indicator lights illuminate automatically.

Menu display	Description
	<b>DPF loads</b> <b>A</b> (white): no load <b>B</b> (green): low load <b>C</b> (yellow): medium load <b>D</b> (red): highest load

## Escalation level

Level	Indication	Description/Measures
<b>1</b>		<p><b>The system is working smoothly</b> If required, automatic regeneration is carried out by the system in the background. No indicator lights are displayed during that.</p> <p>Measures for the operator: none</p>
<b>2</b>		<p><b>There is a fault in the system</b> If the vehicle has to be driven through a danger area, turn off ignition and then turn it on again.</p> <p>Measures for the operator: Work with the vehicle. When that is not possible, fold up the joystick base, press the parking brake and run the engine.</p>



### Information

The indicator lights can be positioned differently based on the vehicle equipment and display.

The indicator lights can illuminate or blink at different speeds.

Level	Menu display	Description/Measures
<b>3</b>		<p><b>There is a serious fault in the system</b>            Level 3 is the last chance, to prevent service regeneration.            After the engine is started, rpm falls down to the idling speed step by step. The rpm can be increased again, only after carrying out a regeneration.</p> <p>If the vehicle has to be driven through a danger area, turn off ignition and then turn it on again. However, that should only be done in case of an emergency, since that could lead to a need of service regeneration.</p> <p>Measures for the operator:            Raise the control lever base, apply parking brake and let the engine run.</p>
<b>4</b>		<p><b>There is an irreversible fault in the system</b>            A service regeneration must be carried out or the diesel particulate filter must be replaced.            It is not possible to have a higher rpm anymore.            The vehicle can only be driven with a lot of limitations.</p> <p>Measures for the operator:            Contact a Wacker Neuson service center.</p>



### Information

The indicator lights can be positioned differently based on the vehicle equipment and display.  
 The indicator lights can illuminate or blink at different speeds.  
 The engine warning **and** engine stop **indicator lights** may also illuminate if another fault occurs. This does not depend on the current load.

## 7.23 Machine preservation

Each vehicle is partly preserved at the plant (for example in the engine compartment). Operation in an aggressive environment (for example salt deposits) is prohibited.



Notes:



## 8 Malfunctions

### 8.1 Diesel engine




#### Information

Troubleshooting may be performed only by a Wacker Neuson service center.

#### Engine warning lights 404F




Engine warning	Engine stop	Description
Yellow	Red	Indicator light color
		
Off	Off	No malfunction.
On	Off	The engine runs correctly, but there is an error in the electronic engine management. Contact a Wacker Neuson service center.
Flashes	Off	The engine runs correctly, but a diagnosis or error code is issued causing a reduction of engine power. Contact a Wacker Neuson service center.
Flashes	On	Engine is about to be shut down, or is already shut down. Stop the engine immediately and contact a Wacker Neuson service center.

#### Engine and engine oil indicator lights 404F








Engine warning	Engine stop	Oil pressure	Description
Yellow	Red	Red	Indicator light color
			
On	On	On	All warning and indicator lights illuminate for a few seconds if the starting key is turned to position 1. If the engine stop or oil pressure light does not illuminate, stop vehicle operation immediately and contact a Wacker Neuson service center.
Off	Off	Off	No malfunction.
On	On	On	Low oil pressure (if the oil pressure indicator light illuminates during operation). Check the oil level and add oil if necessary – <a href="#">see chapter “Adding engine oil” on page 7-42.</a> If the malfunction is still indicated, stop the engine and contact a Wacker Neuson service center.






### Engine oil indicator lights 404D

Engine warning	Engine stop	Oil pressure	Description
Yellow	Red	Red	Indicator light color
			
--	--	On	<p>Low oil pressure (if the oil pressure indicator light illuminates during operation). Check the oil level and add oil if necessary – <a href="#">see chapter “Adding engine oil” on page 7-42.</a></p> <p>If the malfunction is still indicated, stop the engine and contact a Wacker Neuson service center.</p>

## 8.2 Malfunctions (display element/multi-functional display)

Symbol	Description	See
	<b>Brake accumulator</b> Stop the machine and turn off the engine immediately. Contact a Wacker Neuson service center.	--
	<b>Engine stop</b> Stop the engine immediately. Contact a Wacker Neuson service center.	--
	<b>General malfunction</b> Stop the engine immediately. Contact a Wacker Neuson service center.	--
	<b>Low Engine Oil Pressure</b> Stop the engine immediately. Contact a Wacker Neuson service center.	--
	<b>Overspeed</b> Slow down the machine with the brake pedal until the warning light goes out.	--
	<b>Wrong pilot control pressure</b> Stop the engine immediately. Contact a Wacker Neuson service center.	--
	<b>Charge indicator light</b> Possible alternator or V-belt malfunction. <b>Note:</b> Increase the engine speed. The electrical system is in working order if the charge indicator light goes out after about one minute. If the malfunction is still indicated, stop the engine immediately and contact a Wacker Neuson service center.	--



Symbol	Description	See
	<p><b>Hydraulic oil temperature too high</b></p> <ul style="list-style-type: none"> <li>• Check the hydraulic oil level and add oil if necessary.</li> <li>• Hydraulic oil cooler dirty; clean hydraulic oil cooler if necessary.</li> </ul> <p><b>Note:</b> If the malfunction is still indicated despite having cleaned the hydraulic-oil radiator and added oil, stop the engine and contact a Wacker Neuson service center.</p>	<p><a href="#">7-48</a> <a href="#">7-49</a> <a href="#">7-45</a></p>
	<p><b>Replace the hydraulic oil filter</b></p> <p>Contact a Wacker Neuson service center.</p>	--
	<p><b>Dirty air filter</b></p> <p>Contact a Wacker Neuson service center.</p>	--
SPN 97	Water in fuel system. Empty the water separator.	<a href="#">7-37</a>

- Symbols are listed according to priority.
- Additionally an exclamation mark can appear in the display element or the multifunctional display and a buzzer can sound. Contact a Wacker Neuson service center in case of malfunctions or signs that are not listed in the following tables or that persist after maintenance has been performed correctly.



<b>Malfunction/sign</b>	<b>Possible cause</b>	<b>Remedy</b>	<b>See</b>
Engine does not start or is not easy to start	Empty fuel tank	Refueling	<a href="#">7-33</a>
	Malfunctioning or empty battery	Replace the battery	<a href="#">7-53</a>
	Malfunctioning fuse	Check the fuse	<a href="#">9-8</a>
Engine starts, but does not run smoothly or faultless	Air in fuel system	Let the engine run	<a href="#">7-37</a>
	Water in fuel system	Empty the water separator.	<a href="#">7-37</a>
Engine has little power; Error message SPN 105	High intake air temperature due to a defective or poorly fitted air filter gasket (404J)	Check the air filter gasket and, if necessary, contact an authorized workshop.	<a href="#">7-46</a>
The rpm does not increase for a particular amount of time after starting the engine	The diesel particle filter is in the escalation levels 2 or 3.	Refer to chapter <b>Exhaust gas cleaning (404J)</b>	<a href="#">7-68</a>
The torque has reduced	The diesel particle filter is in the escalation levels 3 or 4.		
Rpm is reduced gradually			
Rpm cannot be increased			
Shortened DPF regenerations intervals	Avoid regular operation when the engine is cold.	Avoid operation when the engine is cold	<a href="#">7-59</a> ; <a href="#">7-68</a>
	Regeneration discontinued	Enable regeneration	
	Polluted air filter	Refer to chapter <b>Exhaust gas cleaning (404F/ 404J)</b>	<a href="#">7-59</a> ; <a href="#">7-68</a>
	Vehicle is being operated at great heights		
	Incorrect engine oil	Observe the <b>fuel, lubricants, and coolants list</b>	<a href="#">7-21</a>
	Wrong diesel fuel		
Machine pulls to the right or left	Different tire pressure	Check the tire pressure	<a href="#">9-4</a>
	Uneven tire wear	Contact a Wacker Neuson service center	--
None of the hydraulic functions can be operated	Control lever base raised	Fold down the control lever base	<a href="#">4-51</a>
Speed ranges cannot be changed	Service brake not fully pressed	Press the service brake fully	<a href="#">5-3</a>



Malfunction/sign	Possible cause	Remedy	See
Working light or horn does not work.	Malfunctioning fuse	Check the fuse; Check the plug connection at the work light	9-8
Fan does not run	Malfunctioning fuse	Check the fuse	9-8
	Electrical fault	Contact a Wacker Neuson service center	--
Reduced or no cooling capacity	Not enough refrigerant in the system	Contact a Wacker Neuson service center	--
	Malfunctioning V-belt		
	Dirty condenser	Contact a Wacker Neuson service center	--
	Temperature controller set to heating	Set the temperature controller to cooling	5-35
Reduced heating output or none at all	Malfunctioning thermostat	Contact a Wacker Neuson service center	--
	Temperature controller set to cooling	Set temperature controller to heating	5-35
Loss of refrigerant	Loose hose connection	Contact a Wacker Neuson service center	----
	Leak in system		
Very loud system	Malfunctioning V-belt	Contact a Wacker Neuson service center	--
	Damaged air conditioning compressor		
	Damaged fan motor		

**Service menu/error messages**

Observe the following if an error is displayed in the multi-functional display:

In case of serious errors, stop the vehicle immediately.

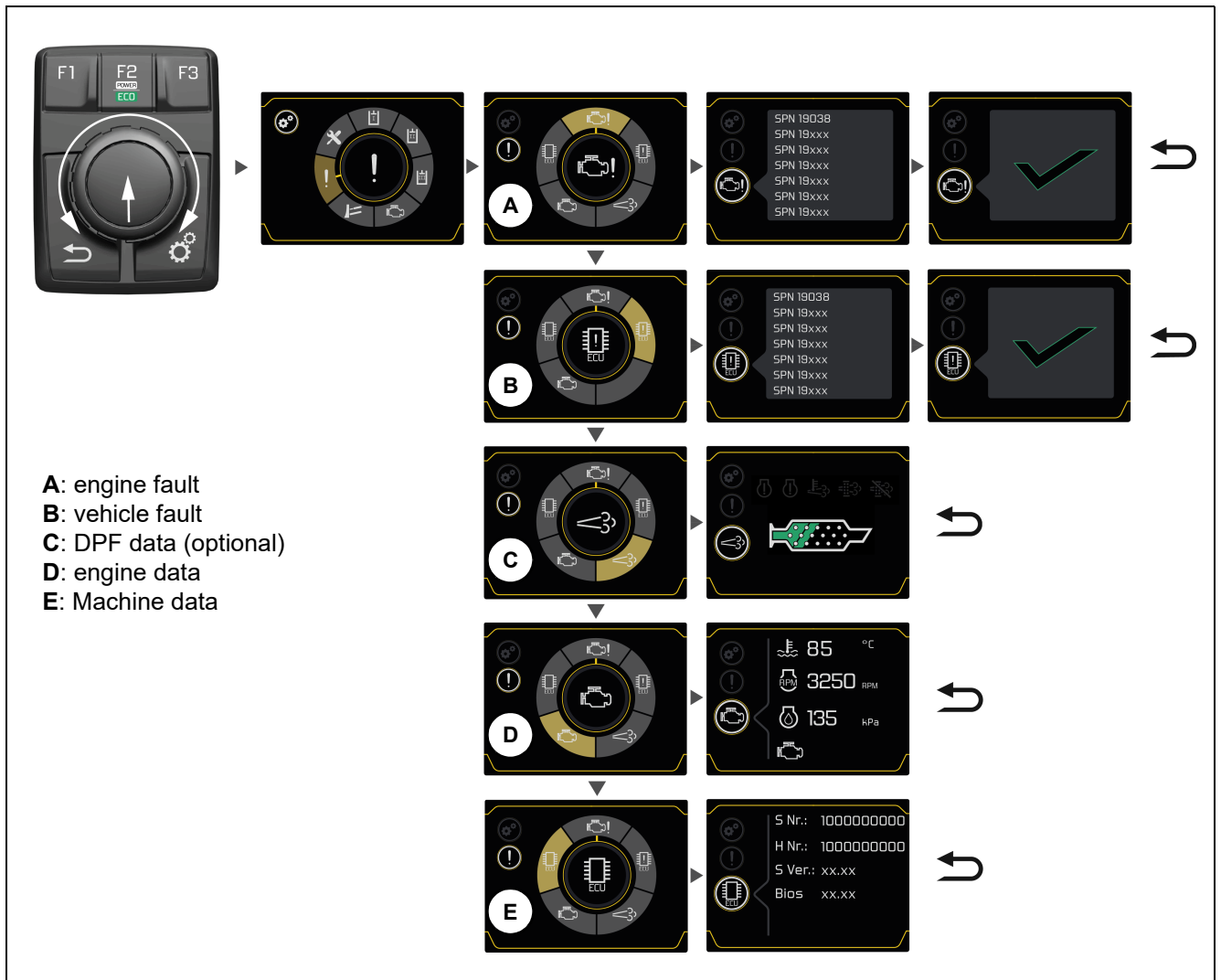
- Engine power is reduced.
- Stop and park the vehicle.
- Contact a Wacker Neuson service center and have the malfunction rectified.

Machine travel and operation is possible in case of minor errors.

- Engine power is not reduced.
- Contact a Wacker Neuson service center and have the malfunction rectified.

**i Information**

Any faults present appear in the multi-functional display for a few seconds after starting the engine.



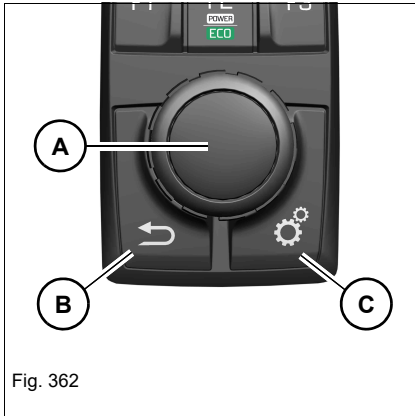


Fig. 362

### Performing the adjustments

- Press push button **C** to call the settings.
- The settings are selected (turn) and confirmed (press) with adjustment button **A**.

Push button **B** (return) takes you back to the previous menu level.

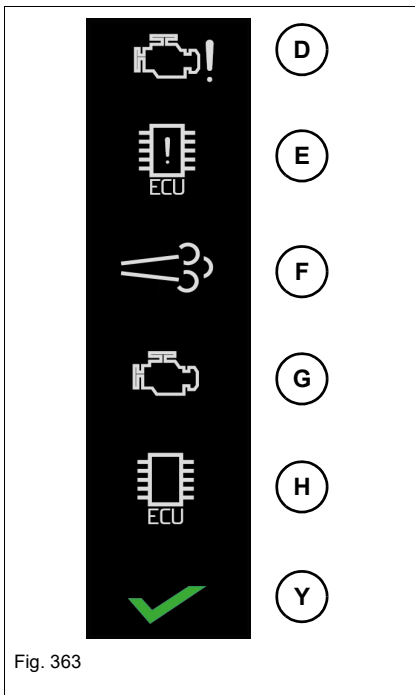


Fig. 363

### Symbols

**D:** Engine fault

**E:** Vehicle fault

**F:** Diesel particulate filter data

**G:** Engine data

**H:** Machine data

**J:** No faults

Push button **B** (return): back to previous menu.

## 9 Technical data

### 9.1 Models and trade names

– see chapter “Model designations and trade names” on page 3-2

### 9.2 Engine

Engine <sup>1</sup>	EW65	
Manufacturer	Perkins	
Type	404D-22T	404F-22T
Design	Water-cooled 4-cylinder diesel engine	
Intake system	Turbo-charging	
Fuel injection system	Indirect	
Engine management	Electronic	
Displacement	2216 cm <sup>3</sup> (129 in <sup>3</sup> )	
Nominal bore and stroke	84 mm x 100 mm (3.3 x 4 in)	
Rated output at rated speed	36.4 kW at 2500 min <sup>-1</sup> (48.8 hp at 2500 rpm)	45.5 kW at 3000 min <sup>-1</sup> (61 hp at 3000 rpm)
Engine power at preset maximum engine speed	36.3 kW at 2200 min <sup>-1</sup> (48.7 hp at 2200 rpm)	45 kW at 2600 min <sup>-1</sup> (60.3 hp at 2600 rpm)
Max. torque	190 Nm at 1700 min <sup>-1</sup> (140 ft.lbs. at 1700 rpm)	192 Nm at 1800 min <sup>-1</sup> (142 ft.lbs. at 1800 rpm)
Max. engine speed without load	2000 rpm	2000 rpm
	--	Mountain mode : 2400 rpm
Lower idling speed	1200 min <sup>-1</sup> (rpm)	
Preheating system	Glow plugs	
Exhaust Aftertreatment	--	Diesel particulate filter
Exhaust values according to	EU Stage III A	EU Stage III B EPA Tier 4 final <sup>2</sup>

1. Output values can vary by +/- 5%.

2. For diesel engines from production date of 2019, only EPA Tier 4 final is valid.



Engine <sup>1</sup>	EW65	
Manufacturer	Perkins	
Type	404F-E22TA	404J-E22T
Design	Water-cooled 4-cylinder diesel engine	
Intake system	Turbo-charging, charge air cooling	Turbo-charging
Fuel injection system	Direct	
Engine management	Electronic	
Displacement	2216 cm <sup>3</sup> (129 in <sup>3</sup> )	
Nominal bore and stroke	84 mm x 100 mm (3.3 x 4 in)	
Rated output at rated speed	50 kW at 2800 min <sup>-1</sup> (67.1 hp at 2800 rpm)	45 kW at 2800 min <sup>-1</sup> (60.3 hp at 2800 rpm)
Engine power at preset maximum engine speed (work mode)		
ECO	39.2 kW at 1800 min <sup>-1</sup> (52.6 hp at 1800 rpm)	39.8 kW at 1800 min <sup>-1</sup> (53.4 hp at 1800 rpm)
PWR	43.5 kW at 2000 rpm (58.3 hp at 2000 rpm)	42.0 kW at 2000 rpm (56.4 hp at 2000 rpm)
Engine power at preset maximum engine speed (street mode)		
PWR	49.8 kW at 2600 min <sup>-1</sup> (66.8 hp at 2600 rpm)	42.0 kW at 2000 rpm (56.4 hp at 2000 rpm)
Max. torque	208 Nm at 1800 rpm (153 ft.lbs. at 1800 rpm)	222 Nm at 1600 min <sup>-1</sup> (163 ft.lbs. at 1600 rpm)
Max. engine speed without load (work mode)	2000 rpm	
Max. engine speed without load (street mode)	2600 min <sup>-1</sup> (rpm)	2000 rpm
Lower idling speed	1200 min <sup>-1</sup> (rpm)	
Preheating system	Glow plugs	
Exhaust Aftertreatment	Diesel oxidation catalyst	DPF
Exhaust values according to	EU Stage III B EPA Tier 4 final <sup>2</sup>	EU Stage V EPA Tier 4 final

1. Output values can vary by +/- 5%.

2. For diesel engines from production date of 2019, only EPA Tier 4 final is valid.



### 9.3 Traveling drive

	<b>EW65</b>
Travel drive	Variable displacement pump flanged direct onto diesel engine, progressive variable displacement motor on rear axle gearbox
Hydraulic pump conveying capacity	20 km/h version: 99 l/min (26.2 gal/min) 30 km/h version: 117 l/min (30.9 gal/min)
Power transmission	Hydrostatic drive with automatic adaptation of traction force and speed over the entire speed range by means of speed-sensitive control in road-travel mode (automotive). In operating mode with constant diesel engine speed: traveling drive is controlled directly with the accelerator pedal (non-automotive). Continuous forward and reverse speed control. Controlled via accelerator pedal, 4 wheel drive from rear axle gearbox to front axle via cardan shaft.
Max. operating pressure (travel operation)	Max. 450 bar (6527 psi)

### 9.4 Brakes

	<b>EW65</b>
Service brake	Dual-circuit brake on front and rear axles, each with its own accumulator. Wet multi-disk brake in center housing of axle.
Parking brake	Hydromechanically actuated spring-type disk brake on rear axle input, brake effect on all 4 wheels via cardan shaft, electro-hydraulic actuation.
Swiveling brake	The hydrostatic swiveling motor acts as a wear and tear resistant swiveling brake. Braking is performed automatically (with a time delay) via a spring-type multidisk brake (unlocked hydraulically) integrated in the gear motor.
Secondary brake	Via the gearbox, the hydrostatic drive brakes the rear axle as an additional wear-resistant secondary brake.



## 9.5 Tires

Tire size	Manufacturer	Tire size	Profile	Load	Tire pressure bar (psi)
Individual tires 300	Mitas	300-15	FL-08	22 PR	10 (145)
Individual tires 425	Delcora	425/40B17	GSP+	22 PR	9 (131)
Twin tires	Mitas	7,50-15	FL-08	14 PR	9,25 (134)

## 9.6 Steering system

	EW65
Steering angle	Max. 38°
Power supply	Via gear pump on power take-off to brake and pressure transmission to steering unit.
Standard steering system	Fully hydraulic, proportionally steered front axle with steering control unit and steering cylinder integrated in axle

## 9.7 Operating hydraulics

	EW65
Max. operating pressure	240 ±5 bar (3481 ±72 psi)
Hydraulic reservoir capacity	92 Liter (24 gal)
Working pump conveying capacity	144 l/min (38 gal/min)
Ancillary drive pump conveying capacity (steering system, brakes)	35.2 l/min (9.3 gal/min)
Filter	Suction and return filter
Swivel range of upper carriage	360°
Rotation speed of upper carriage	9 rpm

## Maximum speed

### Road-travel mode

		<b>EW65</b>
20 km/h (12 mph)	--	20 km/h (12 mph)
30 kph (19 mph)/option	Speed range 1	10 km/h (6 mph)
	Speed range 2	30 km/h (19 mph)

### Operating mode

		<b>EW65<sup>1</sup></b>
20 km/h (12 mph)	Speed range 1	5 km/h (3 mph)
	Speed range 2	18 km/h (11 mph)
30 kph (19 mph)/option	Speed range 1	7 km/h (4 mph)
	Speed range 2	18 km/h (11 mph)

1. The maximum speed in operating mode depends on the tires and may deviate by +/-10%. In Eco mode, the maximum speed may be slightly below the specified values.

## 9.8 Electrical system

### **WARNING**

#### **Fire hazard in case of incorrect handling of electric components!**

Can cause serious injury or death.

- ▶ Use only specified fuses.
- ▶ Do not repair or bypass fuses.
- ▶ If a replaced fuse is blown again directly, do not put the vehicle into operation and contact a Wacker Neuson service center.

### **NOTICE**

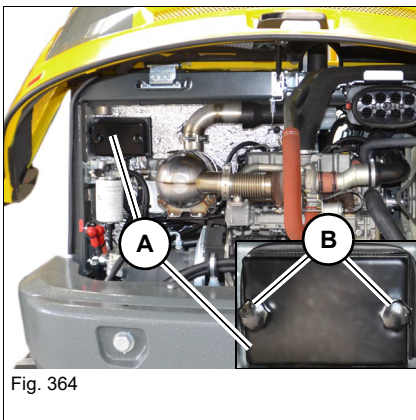
Explosion hazard in case of incorrect handling of fuses.

- ▶ Use only specified fuses.
- ▶ Do not repair or bypass fuses.
- ▶ If a replaced fuse is blown again directly, do not put the vehicle into operation and contact a Wacker Neuson service center.

## Electrical components

	EW65
Alternator	12 V/85 A
Alternator (404F-E22TA)	12V/120A
Starter (404D)	12 V/2 kW (2.7 hp)
Starter (404F-22T)	12 V/2.2 kW (3 hp)
Starter (404F-E22TA)	12V/2 kW (2.7 hp)
Battery (according to DIN EN 50342, DIN IEC 60095-2)	Version 1: 12 V/88 Ah Version 2: 12 V/100 Ah

## Main fuse box



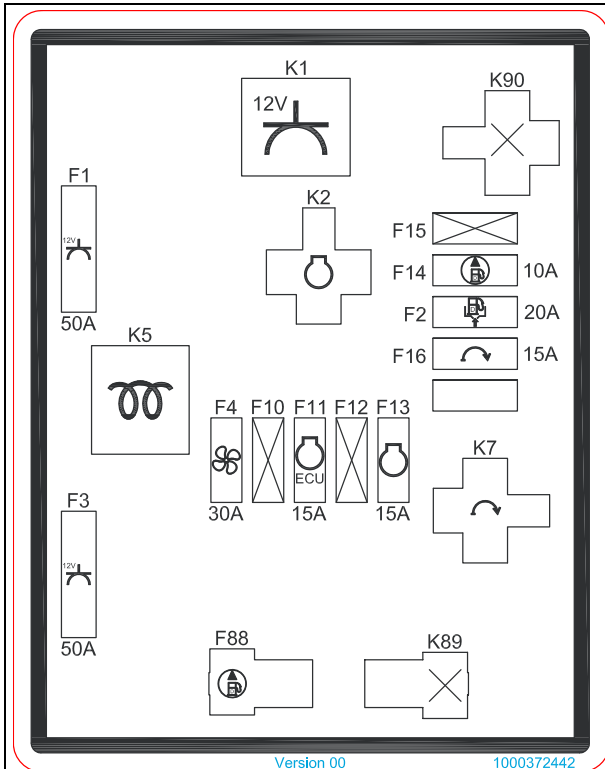
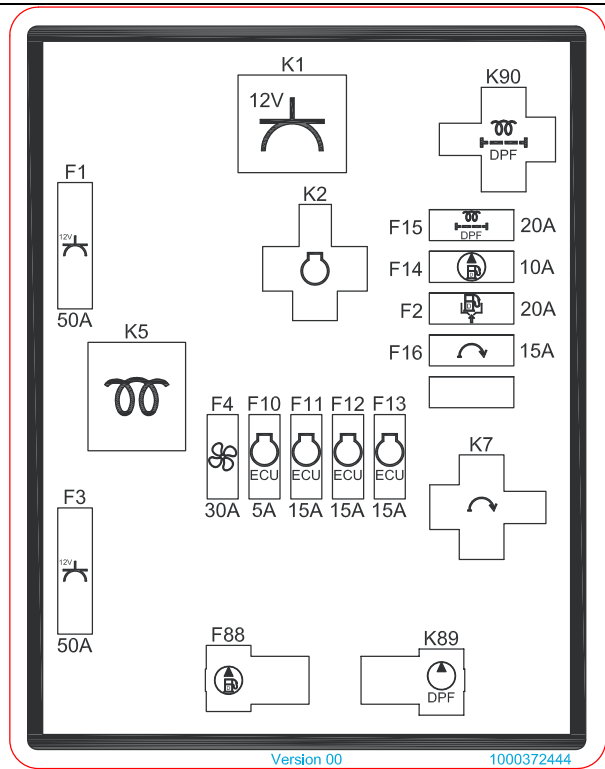
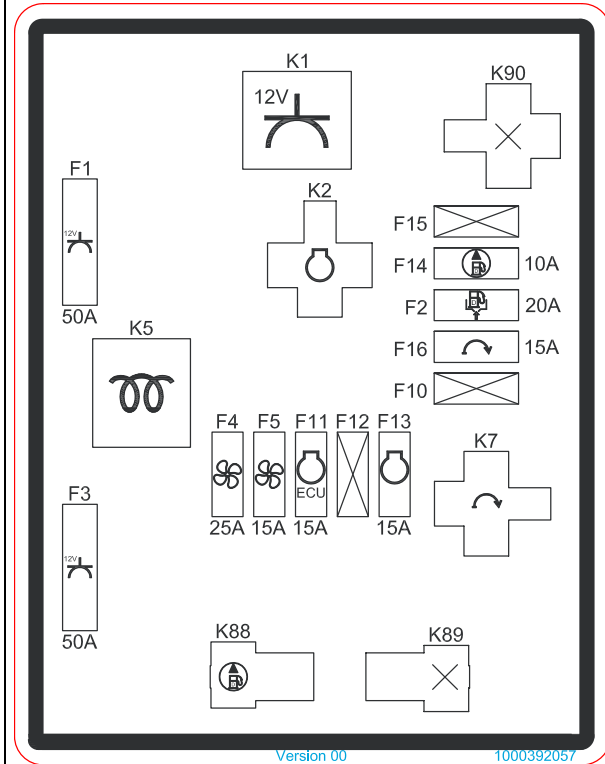
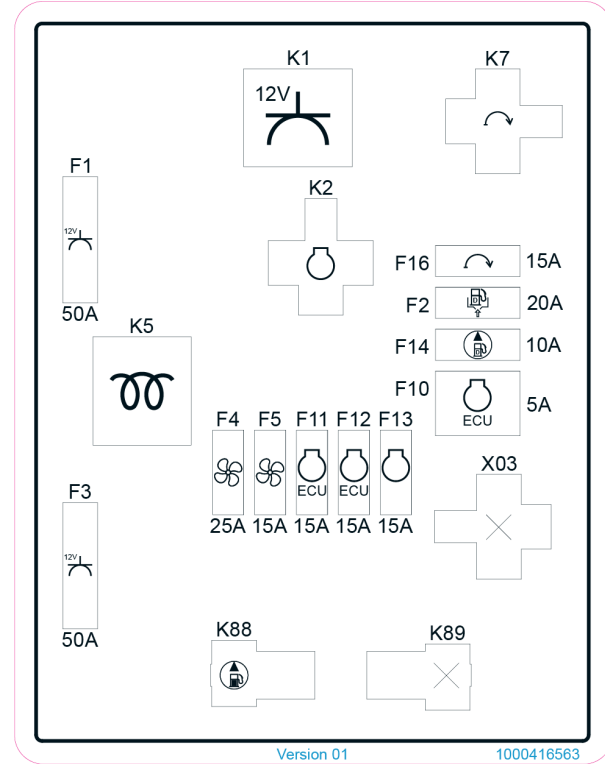
The main fuse box **A** is located on the partition wall in the engine compartment.

### 1. Opening:

1. Stop and park the vehicle. Stop the engine.
  - See "**Preparing lubrication**".
2. Open the engine cover.
3. Loosen screws **B** and remove the cover.

### Closing:

1. Install the cover and tighten screws **B**.

**Assignment****Perkins 404D-22T  
(Version 1)****Perkins 404F-22T****Perkins 404F-E22TA  
Perkins 404D-22T  
(Version 2)****Perkins 404J-E22T  
Perkins 404D-22T  
(Version 3)**

### Cabin fuse box



The cabin fuse box is located on the left of the operator seat.

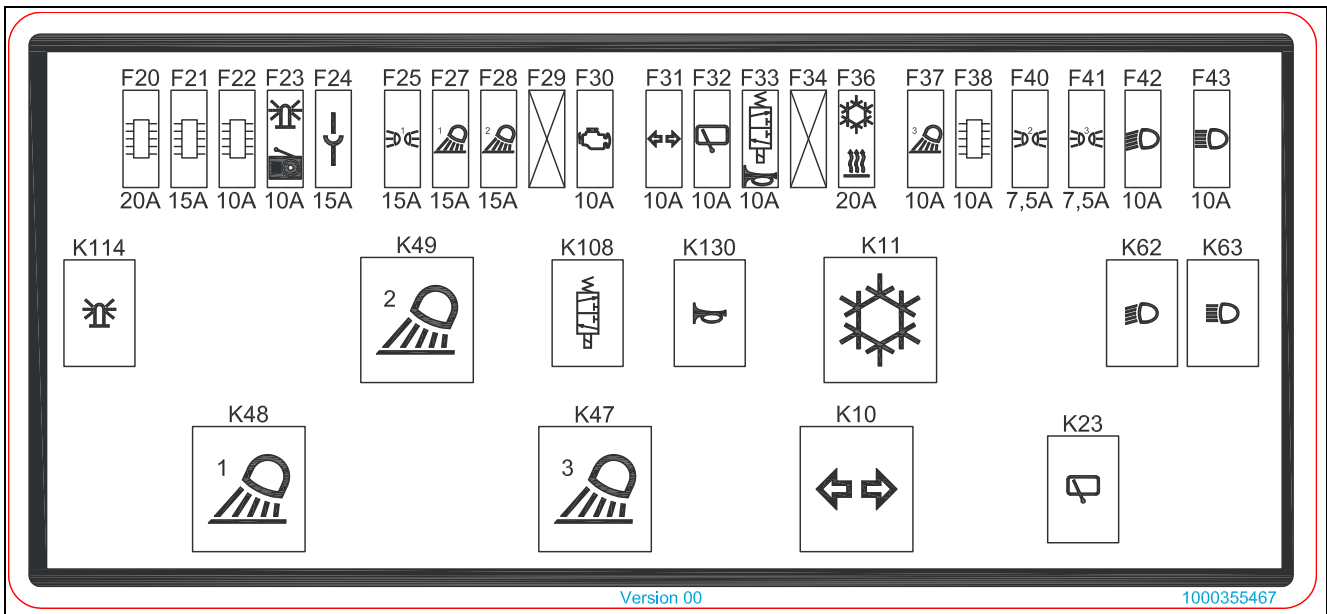
**Opening:**

1. Stop and park the vehicle. Stop the engine.
  - See "Preparing lubrication".
2. Loosen screw **C** and remove the cover.

**Closing:**

1. Install the cover and tighten screw **C**.

**Assignment:**



Version 00

1000355467



Fuse	Relays	Protected circuits
F001	K001	12V15-1
F002	--	Fuel-filling pump
F003	--	12V30-1
F004	--	Air-conditioning fan
F005	--	Air-conditioning fan
F010	--	Engine Controller
F011	--	Engine Controller
F012	--	Not assigned
F013	--	Engine Controller
F014	K088, K089	Fuel pump, DPF pump
F015	K90	DPF glow plug
F016	K7	Starter terminal 50
F020	--	Control valve TTC 77
F021	--	Control valve TTC 30
F022	--	Control Unit
F023	K114	Rotating beacon, radio, Telematic
F024	--	12 V connection
F025	--	Hazard warning lights, clearance light
F027	K048	Working light on chassis
F028	K049	Roof light
F029	--	Not assigned
F030	--	Control terminal 15
F031	--	Turn indicators
F032	K023	Wiper
F033	K108, K130	Hydraulic valves, horn, air-suspension comfort seat
F034	--	Travel drive
F036	K011	Heating, air conditioning
F037	K047	Boom working light
F038	--	IO controller IO, starter
F040	--	Clearance light
F041	--	Clearance light
F042	K062	Low beam
F043	K063	High beam
--	K010	Turn indicators
--	K005	Preheating
--	K002	Main relay



## Illuminants

	Type	
Working lights	Halogen lamp	12 V/55 W H3
Working lights	LED <sup>1</sup>	--
Interior light	Festoon lamp	C5W 12 V/5 W
Rotating beacon	Halogen lamp	12V/55W H1
Rotating beacon	LED <sup>1</sup>	--
Light cover (option)	Bulb	12V/5W

1. LED bulbs cannot be replaced.

## Power tilt (option)

	EW65
Swiveling range	about 180°

## 9.9 Tightening torques

### General tightening torques

Property class	8.8	10.9	12.9	8.8	10.9
Screw dimensions	Screws according to DIN 912, DIN 931, DIN 933, etc.			Screws according to DIN 7984	
	Nm (ft.lbs.)	Nm (ft.lbs.)	Nm (ft.lbs.)	Nm (ft.lbs.)	Nm (ft.lbs.)
M5	5,5 (4)	8 (6)	10 (7)	5 (4)	7 (5)
M6	10 (7)	14 (10)	17 (13)	8,5 (6)	12 (9)
M8	25 (18)	35 (26)	42 (31)	20 (15)	30 (22)
M10	45 (33)	65 (48)	80 (59)	40 (30)	59 (44)
M12	87 (64)	110 (81)	147 (108)	69 (51)	100 (74)
M14	135 (100)	180 (133)	230 (170)	110 (81)	160 (118)
M16	210 (155)	275 (203)	350 (258)	170 (125)	250 (184)
M18	280 (207)	410 (302)	480 (354)	245 (181)	345 (254)
M20	410 (302)	570 (420)	690 (509)	340 (251)	490 (361)
M22	550 (406)	780 (575)	930 (686)	460 (339)	660 (487)
M24	710 (524)	1000 (738)	1190 (878)	590 (435)	840 (620)
M27	1040 (767)	1480 (1092)	1770 (1305)	870 (642)	1250 (922)
M30	1420 (1047)	2010 (1482)	2400 (1770)	1200 (885)	1700 (1254)



<b>Tightening torques/fine-pitch thread</b>					
<b>Property class</b>	<b>8.8</b>	<b>10.9</b>	<b>12.9</b>	<b>8.8</b>	<b>10.9</b>
<b>Screw dimensions</b>	<b>Screws according to DIN 912, DIN 931, DIN 933, etc.</b>			<b>Screws according to DIN 7984</b>	
	<b>Nm (ft.lbs.)</b>	<b>Nm (ft.lbs.)</b>	<b>Nm (ft.lbs.)</b>	<b>Nm (ft.lbs.)</b>	<b>Nm (ft.lbs.)</b>
M8X1.0	25 (18)	37 (28)	43 (32)	22 (16)	32 (24)
M10X1.0	50 (37)	75 (55)	88 (65)	43 (32)	65 (48)
M10X1.25	49 (36)	71 (52)	83 (61)	42 (31)	62 (46)
M12X1.25	87 (64)	130 (96)	150 (111)	75 (55)	110 (81)
M12X1.5	83 (61)	125 (92)	145 (107)	72 (53)	105 (77)
M14X1.5	135 (100)	200 (148)	235 (173)	120 (89)	175 (129)
M16X1.5	210 (155)	310 (229)	360 (266)	180 (133)	265 (195)
M18X1.5	315 (232)	450 (332)	530 (391)	270 (199)	385 (284)
M20X1.5	440 (325)	630 (465)	730 (538)	375 (277)	530 (391)
M22X1.5	590 (435)	840 (620)	980 (723)	500 (369)	710 (524)
M24X2.0	740 (546)	1070 (789)	1250 (922)	630 (465)	900 (664)
M27X2.0	1100 (811)	1550 (1143)	1800 (1328)	920 (679)	1300 (959)
M30X2.0	1500 (1106)	2150 (1586)	2500 (1844)	1300 (959)	1850 (1364)

## 9.10 Coolant Compound table

Outside temperature <sup>1</sup>	Distilled water	Coolant <sup>2</sup>
Up to °C (°F)	% by volume	% by volume
-37 (-34,6)	50	50

1. Use the 1:1 concentration for warm outside temperatures, too, to ensure protection against corrosion, cavitation, and deposits.
2. Do not mix the coolant with other coolants.

## 9.11 Noise emissions

	EW65 (404D)	EW65 (404F-22T)	EW65 (404F-E22TA)	EW65 (404J-E22T)
Measured sound power level LwA <sup>1</sup>	96.2 dB(A)	96.1 dB(A)	96.8 dB(A)	94.9 dB(A)
Guaranteed sound power level LwA <sup>1</sup>	97 dB(A)	98 dB(A)	99 dB(A)	97 dB(A)

1. According to ISO 6395 (EC Directives 2000/14/EC and 2005/88/EC)



### Information

Measurements performed on asphalted surface.

## 9.12 Vibrations

Vibrations <sup>1</sup>	
Effective acceleration value for the upper extremities of the body (hand-arm vibration)	< Trigger value < 2.5 m/s <sup>2</sup>
Effective acceleration value for the body (whole-body vibration)	< 0.5 m/s <sup>2</sup>

1. Uncertainty of measurement as per DIN EN 474-1:2014-03

## 9.13 Weights

EW65	Transport weight <sup>1</sup> kg (lbs)	Operating weight <sup>2</sup> kg (lbs)
<b>One-piece boom</b> (short shovel arm)	6472 (14,268)	6753 (14,888)
EW65	Transport weight <sup>1</sup> kg (lbs)	Operating weight <sup>2</sup> kg (lbs)
<b>Triple articulation boom</b> (short shovel arm)	6656 (14,674)	6940 (15,300)

1. Transport weight: basic vehicle (one-piece boom, short stick, single tires 300) + 10% fuel tank capacity
2. Operating weight: basic machine + full fuel tank + backhoe bucket (800 mm) + user (75 kg/165 lbs)



### Information

Weight indications can vary by +/- 2%.

## Determining the loading weight

The basis for calculating the loading weight is the shipping weight indicated on the vehicle nameplate. Add subsequently installed options and attachments (e.g. bucket, Easy Lock, breaker console) to the shipping weight. Add fuel depending on the tank capacity.

Option	EW65 <sup>1</sup> kg (lbs)
FOPS screen	55 (122)
Front Guard	48 (106)
3rd control circuit with proportional controls	41 (91)
Long stick	24 (53)
Preparing the Powertilt	20 (44)
Grab control circuit	16 (36)
Fuel-filling pump	16 (36)
Quickhitch-ready	11 (25)
Attachments – <i>see chapter “Technical data of attachments” on page 9-15</i>	--
Full fuel tank	70 (154)

1. The weight indications for options exclusively refer to Wacker Neuson original accessories.



### Information

The given weights are exemplary. In order to determine the exact weight, the vehicle must be weighed before transportation.



---

## Fields of application and use of attachments

---

### **WARNING**

#### **Accident hazard due to unauthorized attachments!**

If unauthorized attachments are used, the vehicle can tip over, which can lead to serious injury or death.

- ▶ Only use attachments released by Wacker Neuson.
- 

### **NOTICE**

Machine can be damaged due to unreleased attachments.

- ▶ Only use the attachments specified in the table.
- 

Compare the weight of the attachment and its maximum payload with the indications in the relevant lift capacity table or load diagram. Never exceed the maximum payload stated in the lift capacity table or load diagram.

---

### **Information**

Please refer to the Operator's Manual and maintenance manual of the attachment manufacturer for operating and maintenance instructions for attachments such as hammers, grabs, hydraulic quickhitches, etc.

---

## Technical data of attachments

The specified weights are exemplary and only serve as a guide. The actual weight may be lower or higher. In order to determine the actual weight, the attachment must be weighed.

Not all attachments are available for every vehicle.

There may be additional bucket widths that are not specified in this operator's manual.

Only use attachments released by Wacker Neuson. For more information, contact a Wacker Neuson sales partner.

Observe the national and regional regulations.

Vehicle class 5-7 tonnes		
Bucket	Width mm (in)	Weight kg (lbs)
Bucket	300 (12)	105-130 (235-290)
	400 (16)	115-140 (255-310)
	500 (20)	115-140 (255-310)
	600 (24)	125-155 (280-345)
	700 (28)	140-250 (310-555)
	800 (31)	155-290 (345-640)
	900 (35)	285-335 (630-740)
Ditch cleaning bucket	1200 (47)	170-205 (375-455)
	1400 (55)	190-270 (420-600)
	1500 (59)	155-190 (345-420)
Offset bucket	1200 (47)	235-285 (520-630)
	1400 (55)	250-300 (555-665)

Accessories of the vehicle class 5-7 tonnes	Weight kg (lbs)
Consoles (Easy Lock, Lehnhoff system, etc.)	45-100 (100-225)
Hydraulic hammer	285-400 (630-885)
Powertilt (consoles; with Easy Lock etc.)	100-240 (225-530)



### Excavation power

	<b>EW65</b>
Max. tearout force (short stick)	30.8 kN (6924 lbf)
Max. tearout force (long stick)	27.4 kN (6160 lbf)
Max. breakout force (at bucket tooth)	46 kN (10,341 lbf)

## 9.14 Lift capacity/load

### Safety instructions lift capacity tables

Observe the values of the lift capacity tables in normal operation (for example excavating).

Observe the values of the load diagrams in lifting gear applications.

---

 **DANGER**

#### Crushing hazard due to tipping over of vehicle!

The vehicle causes serious injury or death when it tips over.

- ▶ The weight of the attachment and load must be subtracted from the weight specified in the corresponding column in the table.
- ▶ Pay attention to the density of the load.
- ▶ Do not exceed the weights indicated in the lift capacity tables.

---

#### **NOTICE**

If the weight is exceeded, there is a risk of damage to property if the machine tips over.

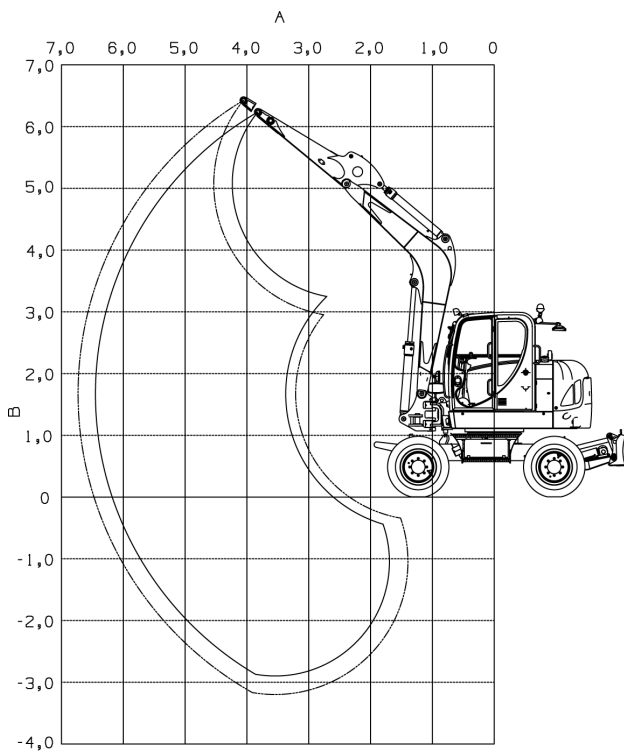
- ▶ Do not exceed the weights indicated in the load diagrams.

---

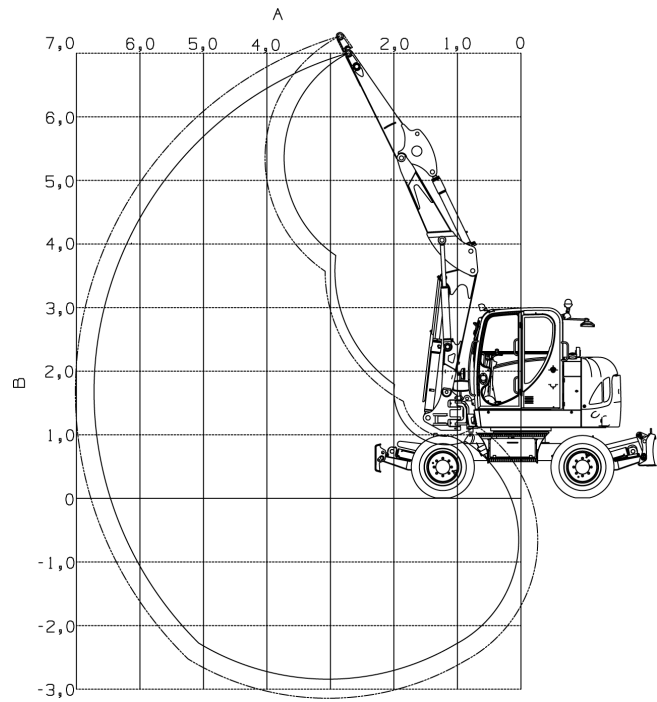
 **Information**

The indications are only approximate values. Uneven ground or poor ground conditions affect vehicle stability. The operator must take these influences into account.

---



One-piece boom



Triple articulation boom

Description	Explanation <sup>1</sup>
A	Reach from live ring center
B	Load hook height
max	Authorized lift capacity with horizontal boom
I	Upper carriage to the front, tipping over stabilization
II	Upper carriage to the front, tipping over front axle
III	Upper carriage 90° to travel gear, no stabilization
IV	Upper carriage to the rear, tipping over rear axle

1. Stabilization: stabilizer blade, parallel stabilizer blade or stabilizer legs



All table values are specified in kg (lbs), in horizontal position on firm and level ground without bucket or attachment (for example a hammer).

The vehicle's lift capacity is restricted by the settings of the pressure limiting valves, the hydraulic output and the hydraulic system's stabilizing features.

Neither 75% of the static tilt load nor 87% of the hydraulic lift capacity is exceeded.

Calculation basis according to ISO 10567

Setting pressure on boom cylinder:

24,000 kPA (3481 psi)

The lift capacity applies to vehicles under the following conditions:

- Lubricants and engine/vehicle fluids at the mandatory levels
- Full fuel tank
- Cab
- Machine at operating temperature
- Operator weight 75 kg (165 lbs)

**Lift capacity tables EW65**

**01: Mono boom/single tires/dozer blade at rear/transport bar for clamshell bucket at front/short stick**

A \ B	2 m (6' - 7")				3 m (9' - 10")				4 m (13' - 1")				5 m (16' - 5")				max			
	I	II	III	IV	I	II	III	IV	I	II	III	IV	I	II	III	IV	I	II	III	IV
4 m	-	-	-	-	-	-	-	-	1161	1161	1161	1161	-	-	-	-	1227	1227	1009	1207
(13' - 1")	-	-	-	-	-	-	-	-	(2,560)	(2,560)	(2,560)	(2,560)	-	-	-	-	(2,706)	(2,706)	(2,225)	(2,662)
3 m	-	-	-	-	-	-	-	-	1252	1252	1195	1252	1226	1226	832	996	1229	1229	831	995
(9' - 10")	-	-	-	-	-	-	-	-	(2,761)	(2,761)	(2,635)	(2,761)	(2,703)	(2,703)	(1,834)	(2,197)	(2,710)	(2,710)	(1,832)	(2,194)
2 m	-	-	-	-	2010	2010	1726	2010	1490	1490	1136	1372	1281	1281	813	977	1255	1243	753	904
(6' - 7")	-	-	-	-	(4,433)	(4,433)	(3,806)	(4,433)	(3,285)	(3,285)	(2,506)	(3,026)	(2,825)	(2,825)	(1,793)	(2,154)	(2,768)	(2,740)	(1,659)	(1,994)
1 m	-	-	-	-	2576	2576	1595	1985	1728	1728	1077	1310	1362	1313	788	950	1295	1219	732	883
(3' - 3")	-	-	-	-	(5,679)	(5,679)	(3,517)	(4,378)	(3,810)	(3,810)	(2,374)	(2,888)	(3,004)	(2,895)	(1,737)	(2,096)	(2,855)	(2,688)	(1,615)	(1,947)
0 m	4853	4853	2877	3853	2743	2743	1539	1924	1841	1783	1040	1270	1361	1297	773	936	1343	1284	766	926
(0' - 0")	10,701	10,701	(6,344)	(8,496)	(6,048)	(6,048)	(3,393)	(4,243)	(4,060)	(3,931)	(2,293)	(2,801)	(3,001)	(2,861)	(1,705)	(2,063)	(2,961)	(2,831)	(1,689)	(2,042)
-1 m	4233	4233	2906	3887	2550	2550	1537	1922	1731	1731	1035	1265	-	-	-	-	1387	1387	882	1070
(-3' - 3")	(9,334)	(9,334)	(6,409)	(8,571)	(5,623)	(5,623)	(3,388)	(4,238)	(3,817)	(3,817)	(2,281)	(2,789)	-	-	-	-	(3,058)	(3,058)	(1,944)	(2,358)
-2 m	3019	3019	2987	3019	1904	1904	1581	1904	-	-	-	-	-	-	-	-	1375	1375	1223	1375
(-6' - 7")	(6,657)	(6,657)	(6,586)	(6,657)	(4,199)	(4,199)	(3,486)	(4,199)	-	-	-	-	-	-	-	-	(3,031)	(3,031)	(2,697)	(3,031)

**02: Mono boom/single tires/dozer blade at rear/transport bar for clamshell bucket at front/long stick**

A \ B	2 m (6' - 7")				3 m (9' - 10")				4 m (13' - 1")				5 m (16' - 5")				max			
	I	II	III	IV	I	II	III	IV	I	II	III	IV	I	II	III	IV	I	II	III	IV
4 m	-	-	-	-	-	-	-	-	1001	1001	1001	1001	-	-	-	-	1114	1114	888	1063
(13' - 1")	-	-	-	-	-	-	-	-	(2,208)	(2,208)	(2,208)	(2,208)	-	-	-	-	(2,457)	(2,457)	(1,958)	(2,343)
3 m	-	-	-	-	-	-	-	-	1113	1113	1113	1113	1105	1105	837	1003	1122	1122	748	897
(9' - 10")	-	-	-	-	-	-	-	-	(2,455)	(2,455)	(2,455)	(2,455)	(2,436)	(2,436)	(1,846)	(2,211)	(2,475)	(2,475)	(1,649)	(1,979)
2 m	-	-	-	-	1763	1763	1757	1763	1364	1364	1143	1364	1193	1193	812	976	1149	1134	683	823
(6' - 7")	-	-	-	-	(3,886)	(3,886)	(3,875)	(3,875)	(3,007)	(3,007)	(2,520)	(3,007)	(2,630)	(2,630)	(1,790)	(2,152)	(2,533)	(2,501)	(1,506)	(1,814)
1 m	-	-	-	-	2415	2415	1608	2002	1637	1637	1076	1310	1305	1305	781	944	1186	1114	665	804
(3' - 3")	-	-	-	-	(5,324)	(5,324)	(3,547)	(4,413)	(3,609)	(3,609)	(2,373)	(2,888)	(2,877)	(2,877)	(1,721)	(2,081)	(2,615)	(2,456)	(1,466)	(1,772)
0 m	5110	5110	2839	3812	2709	2709	1530	1917	1805	1774	1030	1261	1361	1283	758	921	1231	1164	690	837
(0' - 0")	11,268	11,268	(6,261)	(8,405)	(5,972)	(5,972)	(3,374)	(4,226)	(3,980)	(3,911)	(2,271)	(2,780)	(3,000)	(2,828)	(1,672)	(2,030)	(2,714)	(2,566)	(1,522)	(1,845)
-1 m	4600	4600	2858	3833	2632	2632	1513	1898	1778	1756	1014	1244	-	-	-	-	1276	1276	779	946
(-3' - 3")	10,144	10,144	(6,301)	(8,452)	(5,804)	(5,804)	(3,336)	(4,185)	(3,921)	(3,872)	(2,236)	(2,744)	-	-	-	-	(2,813)	(2,813)	(1,717)	(2,085)
-2 m	3576	3576	2924	3576	2163	2163	1542	1929	1374	1374	1041	1273	-	-	-	-	1294	1294	1013	1236
(-6' - 7")	(7,884)	(7,884)	(6,448)	(7,884)	(4,769)	(4,769)	(3,399)	(4,253)	(3,031)	(3,031)	(2,296)	(2,806)	-	-	-	-	(2,853)	(2,853)	(2,233)	(2,725)

**03: Mono boom/single tires/stabilizer legs at rear/transport bar for clamshell bucket at front/short stick**

A \ B	2 m (6' - 7")				3 m (9' - 10")				4 m (13' - 1")				5 m (16' - 5")				max			
	I	II	III	IV	I	II	III	IV	I	II	III	IV	I	II	III	IV	I	II	III	IV
4 m	-	-	-	-	-	-	-	-	1161	1161	1161	1161	-	-	-	-	1227	1227	1017	1205
(13' - 1")	-	-	-	-	-	-	-	-	(2,560)	(2,560)	(2,560)	(2,560)	-	-	-	-	(2,706)	(2,706)	(2,243)	(2,657)
3 m	-	-	-	-	-	-	-	-	1252	1252	1204	1252	1226	1226	839	995	1229	1229	838	993
(9' - 10")	-	-	-	-	-	-	-	-	(2,761)	(2,761)	(2,655)	(2,761)	(2,703)	(2,703)	(1,849)	(2,193)	(2,710)	(2,710)	(1,847)	(2,190)
2 m	-	-	-	-	2010	2010	1739	2010	1490	1490	1145	1370	1281	1281	820	975	1255	1255	759	903
(6' - 7")	-	-	-	-	(4,433)	(4,433)	(3,834)	(4,433)	(3,285)	(3,285)	(2,526)	(3,021)	(2,825)	(2,825)	(1,808)	(2,150)	(2,768)	(2,768)	(1,674)	(1,990)
1 m	-	-	-	-	2576	2576	1608	1981	1728	1728	1086	1307	1362	1335	795	948	1295	1240	739	881
(3' - 3")	-	-	-	-	(5,679)	(5,679)	(3,545)	(4,369)	(3,810)	(3,810)	(2,394)	(2,882)	(3,004)	(2,945)	(1,752)	(2,091)	(2,855)	(2,735)	(1,629)	(1,943)
0 m	4853	4853	2901	3846	2743	2743	1552	1921	1841	1813	1049	1268	1361	1320	780	934	1343	1306	773	924
(0' - 0")	10,701	10,701	(6,396)	(8,480)	(6,048)	(6,048)	(3,422)	(4,235)	(4,060)	(3,998)	(2,312)	(2,795)	(3,001)	(2,910)	(1,721)	(2,059)	(2,961)	(2,880)	(1,704)	(2,038)
-1 m	4233	4233	2930	3880	2550	2550	1550	1918	1731	1731	1044	1262	-	-	-	-	1387	1387	889	1067
(-3' - 3")	(9,334)	(9,334)	(6,461)	(8,555)	(5,623)	(5,623)	(3,417)	(4,230)	(3,817)	(3,817)	(2,301)	(2,784)	-	-	-	-	(3,058)	(3,058)	(1,961)	(2,354)
-2 m	3019	3019	3010	3019	1904	1904	1594	1904	-	-	-	-	-	-	-	-	1375	1375	1233	1375
(-6' - 7")	(6,657)	(6,657)	(6,638)	(6,657)	(4,199)	(4,199)	(3,514)	(4,199)	-	-	-	-	-	-	-	-	(3,031)	(3,031)	(2,720)	(3,031)

**04: Mono boom/single tires/stabilizer legs at rear/transport bar for clamshell bucket at front/long stick**

A \ B	2 m				3 m				4 m				5 m				max			
	(6' - 7'')				(9' - 10'')				(13' - 1'')				(16' - 5'')							
	I	II	III	IV	I	II	III	IV	I	II	III	IV	I	II	III	IV	I	II	III	IV
4 m	-	-	-	-	-	-	-	-	1001	1001	1001	1001	-	-	-	-	1114	1114	895	1061
(13' - 1'')	-	-	-	-	-	-	-	-	(2,208)	(2,208)	(2,208)	(2,208)	-	-	-	-	(2,457)	(2,457)	(1,974)	(2,339)
3 m	-	-	-	-	-	-	-	-	1113	1113	1113	1113	1105	1105	844	1001	1122	1122	754	895
(9' - 10'')	-	-	-	-	-	-	-	-	(2,455)	(2,455)	(2,455)	(2,455)	(2,436)	(2,436)	(1,861)	(2,207)	(2,475)	(2,475)	(1,663)	(1,975)
2 m	-	-	-	-	1763	1763	1763	1763	1364	1364	1152	1364	1193	1193	818	974	1149	1149	689	821
(6' - 7'')	-	-	-	-	(3,886)	(3,886)	(3,886)	(3,886)	(3,007)	(3,007)	(2,540)	(3,007)	(2,630)	(2,630)	(1,805)	(2,148)	(2,533)	(2,533)	(1,519)	(1,810)
1 m	-	-	-	-	2415	2415	1622	1998	1637	1637	1085	1307	1305	1305	787	942	1186	1133	671	802
(3' - 3'')	-	-	-	-	(5,324)	(5,324)	(3,575)	(4,405)	(3,609)	(3,609)	(2,393)	(2,882)	(2,877)	(2,877)	(1,736)	(2,077)	(2,615)	(2,499)	(1,479)	(1,768)
0 m	5110	5110	2863	3804	2709	2709	1543	1913	1805	1804	1039	1258	1361	1305	765	919	1231	1184	697	835
(0' - 0'')	(11,268)	(11,268)	(6,313)	(8,389)	(5,972)	(5,972)	(3,403)	(4,218)	(3,980)	(3,978)	(2,291)	(2,774)	(3,000)	(2,878)	(1,687)	(2,026)	(2,714)	(2,611)	(1,536)	(1,841)
-1 m	4600	4600	2881	3826	2632	2632	1526	1894	1778	1778	1023	1242	-	-	-	-	1276	1276	786	944
(-3' - 3'')	(10,144)	(10,144)	(6,354)	(8,436)	(5,804)	(5,804)	(3,365)	(4,176)	(3,921)	(3,921)	(2,256)	(2,738)	-	-	-	-	(2,813)	(2,813)	(1,732)	(2,081)
-2 m	3576	3576	2948	3576	2163	2163	1555	1925	1374	1374	1050	1270	-	-	-	-	1294	1294	1021	1233
(-6' - 7'')	(7,884)	(7,884)	(6,500)	(7,884)	(4,769)	(4,769)	(3,428)	(4,245)	(3,031)	(3,031)	(2,316)	(2,801)	-	-	-	-	(2,853)	(2,853)	(2,252)	(2,720)

**05: Mono boom/single tires/stabilizer legs at rear/parallel dozer blade at front/short stick**

A \ B	2 m				3 m				4 m				5 m				max			
	(6' - 7'')				(9' - 10'')				(13' - 1'')				(16' - 5'')							
	I	II	III	IV	I	II	III	IV	I	II	III	IV	I	II	III	IV	I	II	III	IV
4 m	-	-	-	-	-	-	-	-	1161	1161	1161	1161	-	-	-	-	1227	1227	1097	1227
(13' - 1'')	-	-	-	-	-	-	-	-	(2,560)	(2,560)	(2,560)	(2,560)	-	-	-	-	(2,706)	(2,706)	(2,420)	(2,706)
3 m	-	-	-	-	-	-	-	-	1252	1252	1252	1252	1226	1226	909	1226	1229	1229	908	1229
(9' - 10'')	-	-	-	-	-	-	-	-	(2,761)	(2,761)	(2,761)	(2,761)	(2,703)	(2,703)	(2,004)	(2,703)	(2,710)	(2,710)	(2,002)	(2,710)
2 m	-	-	-	-	2010	2010	1872	2010	1490	1490	1237	1490	1281	1281	890	1238	1255	1200	825	1151
(6' - 7'')	-	-	-	-	(4,433)	(4,433)	(4,129)	(4,433)	(3,285)	(3,285)	(2,729)	(3,285)	(2,825)	(2,825)	(1,963)	(2,731)	(2,768)	(2,646)	(1,820)	(2,537)
1 m	-	-	-	-	2576	2576	1741	2502	1728	1728	1178	1657	1362	1267	865	1212	1295	1177	805	1129
(3' - 3'')	-	-	-	-	(5,679)	(5,679)	(3,840)	(5,516)	(3,810)	(3,810)	(2,597)	(3,653)	(3,004)	(2,795)	(1,907)	(2,672)	(2,855)	(2,595)	(1,775)	(2,488)
0 m	4853	4853	3143	4853	2743	2690	1685	2441	1841	1721	1141	1617	1361	1252	851	1197	1343	1239	842	1185
(0' - 0'')	(10,701)	(10,701)	(6,931)	(10,701)	(6,048)	(5,931)	(3,716)	(5,382)	(4,060)	(3,795)	(2,516)	(3,566)	(3,001)	(2,760)	(1,876)	(2,639)	(2,961)	(2,732)	(1,857)	(2,613)
-1 m	4233	4233	3173	4233	2550	2550	1683	2438	1731	1715	1136	1612	-	-	-	-	1387	1387	968	1364
(-3' - 3'')	(9,334)	(9,334)	(6,996)	(9,334)	(5,623)	(5,623)	(3,711)	(5,377)	(3,817)	(3,782)	(2,504)	(3,555)	-	-	-	-	(3,058)	(3,058)	(2,135)	(3,008)
-2 m	3019	3019	3019	3019	1904	1904	1727	1904	-	-	-	-	-	-	-	-	1375	1375	1338	1375
(-6' - 7'')	(6,657)	(6,657)	(6,657)	(6,657)	(4,199)	(4,199)	(3,809)	(4,199)	-	-	-	-	-	-	-	-	(3,031)	(3,031)	(2,949)	(3,031)

**06: Mono boom/single tires/stabilizer legs at rear/parallel dozer blade at front/long stick**

A \ B	2 m				3 m				4 m				5 m				max			
	(6' - 7'')				(9' - 10'')				(13' - 1'')				(16' - 5'')							
	I	II	III	IV	I	II	III	IV	I	II	III	IV	I	II	III	IV	I	II	III	IV
4 m	-	-	-	-	-	-	-	-	1001	1001	1001	1001	-	-	-	-	1114	1114	968	1114
(13' - 1'')	-	-	-	-	-	-	-	-	(2,208)	(2,208)	(2,208)	(2,208)	-	-	-	-	(2,457)	(2,457)	(2,135)	(2,457)
3 m	-	-	-	-	-	-	-	-	1113	1113	1113	1113	1105	1105	914	1105	1122	1122	819	1122
(9' - 10'')	-	-	-	-	-	-	-	-	(2,455)	(2,455)	(2,455)	(2,455)	(2,436)	(2,436)	(2,016)	(2,436)	(2,475)	(2,475)	(1,806)	(2,475)
2 m	-	-	-	-	1763	1763	1763	1763	1364	1364	1244	1364	1193	1193	889	1193	1149	1095	751	1052
(6' - 7'')	-	-	-	-	(3,886)	(3,886)	(3,886)	(3,886)	(3,007)	(3,007)	(2,743)	(3,007)	(2,630)	(2,630)	(1,960)	(2,630)	(2,533)	(2,413)	(1,656)	(2,320)
1 m	-	-	-	-	2415	2415	1755	2415	1637	1637	1177	1637	1305	1261	858	1205	1186	1074	733	1033
(3' - 3'')	-	-	-	-	(5,324)	(5,324)	(3,870)	(5,324)	(3,609)	(3,609)	(2,596)	(3,609)	(2,877)	(2,781)	(1,891)	(2,657)	(2,615)	(2,368)	(1,616)	(2,277)
0 m	5110	5110	3105	4820	2709	2683	1677	2433	1805	1712	1131	1608	1361	1237	836	1182	1231	1122	762	1077
(0' - 0'')	(11,268)	(11,268)	(6,848)	(10,628)	(5,972)	(5,915)	(3,697)	(5,365)	(3,980)	(3,775)	(2,494)	(3,546)	(3,000)	(2,728)	(1,842)	(2,606)	(2,714)	(2,474)	(1,679)	(2,374)
-1 m	4600	4600	3124	4600	2632	2632	1660	2414	1778	1694	1115	1591	-	-	-	-	1276	1271	857	1213
(-3' - 3'')	(10,144)	(10,144)	(6,888)	(10,144)	(5,804)	(5,804)	(3,659)	(5,324)	(3,921)	(3,736)	(2,459)	(3,509)	-	-	-	-	(2,813)	(2,803)	(1,891)	(2,675)
-2 m	3576	3576	3190	3576	2163	2163	1688	2163	1374	1374	1142	1374	-	-	-	-	1294	1294	1111	1294
(-6' - 7'')	(7,884)	(7,884)	(7,035)	(7,884)	(4,769)	(4,769)	(3,722)	(4,769)	(3,031)	(3,031)	(2,519)	(3,031)	-	-	-	-	(2,853)	(2,853)	(2,450)	(2,853)

**07: Mono boom/single tires/stabilizer legs at front/parallel dozer blade at rear/short stick**

A B	2 m (6' - 7")				3 m (9' - 10")				4 m (13' - 1")				5 m (16' - 5")				max			
	I	II	III	IV	I	II	III	IV	I	II	III	IV	I	II	III	IV	I	II	III	IV
	4 m	-	-	-	-	-	-	-	-	1161	1161	1161	1161	-	-	-	-	1227	1227	1097
(13' - 1")	-	-	-	-	-	-	-	-	(2,560)	(2,560)	(2,560)	(2,560)	-	-	-	-	(2,706)	(2,706)	(2,420)	(2,706)
3 m	-	-	-	-	-	-	-	-	1252	1252	1252	1252	1226	1226	909	1192	1229	1229	908	1190
(9' - 10")	-	-	-	-	-	-	-	-	(2,761)	(2,761)	(2,761)	(2,761)	(2,703)	(2,703)	(2,004)	(2,628)	(2,710)	(2,710)	(2,002)	(2,625)
2 m	-	-	-	-	2010	2010	1872	2010	1490	1490	1237	1490	1281	1281	890	1172	1255	1255	825	1088
(6' - 7")	-	-	-	-	(4,433)	(4,433)	(4,129)	(4,433)	(3,285)	(3,285)	(2,729)	(3,285)	(2,825)	(2,825)	(1,963)	(2,585)	(2,768)	(2,768)	(1,820)	(2,400)
1 m	-	-	-	-	2576	2576	1741	2371	1728	1728	1178	1569	1362	1337	865	1146	1295	1242	805	1066
(3' - 3")	-	-	-	-	(5,679)	(5,679)	(3,840)	(5,228)	(3,810)	(3,810)	(2,597)	(3,459)	(3,004)	(2,948)	(1,907)	(2,526)	(2,855)	(2,738)	(1,775)	(2,351)
0 m	4853	4853	3143	4606	2743	2743	1685	2310	1841	1815	1141	1530	1361	1322	851	1131	1343	1308	842	1119
(0' - 0")	(10,701)	(10,701)	(6,931)	(10,156)	(6,048)	(6,048)	(3,716)	(5,094)	(4,060)	(4,002)	(2,516)	(3,373)	(3,001)	(2,914)	(1,876)	(2,493)	(2,961)	(2,884)	(1,857)	(2,468)
-1 m	4233	4233	3173	4233	2550	2550	1683	2308	1731	1731	1136	1524	-	-	-	-	1387	1387	968	1290
-(3' - 3")	(9,334)	(9,334)	(6,996)	(9,334)	(5,623)	(5,623)	(3,711)	(5,089)	(3,817)	(3,817)	(2,504)	(3,361)	-	-	-	-	(3,058)	(3,058)	(2,135)	(2,844)
-2 m	3019	3019	3019	3019	1904	1904	1727	1904	-	-	-	-	-	-	-	-	1375	1375	1338	1375
-(6' - 7")	(6,657)	(6,657)	(6,657)	(6,657)	(4,199)	(4,199)	(3,809)	(4,199)	-	-	-	-	-	-	-	-	(3,031)	(3,031)	(2,949)	(3,031)

**08: Mono boom/single tires/stabilizer legs at front/parallel dozer blade at rear/long stick**

A B	2 m (6' - 7")				3 m (9' - 10")				4 m (13' - 1")				5 m (16' - 5")				max			
	I	II	III	IV	I	II	III	IV	I	II	III	IV	I	II	III	IV	I	II	III	IV
	4 m	-	-	-	-	-	-	-	-	1001	1001	1001	1001	-	-	-	-	1114	1114	968
(13' - 1")	-	-	-	-	-	-	-	-	(2,208)	(2,208)	(2,208)	(2,208)	-	-	-	-	(2,457)	(2,457)	(2,135)	(2,457)
3 m	-	-	-	-	-	-	-	-	1113	1113	1113	1113	1105	1105	914	1105	1122	1122	819	1078
(9' - 10")	-	-	-	-	-	-	-	-	(2,455)	(2,455)	(2,455)	(2,455)	(2,436)	(2,436)	(2,016)	(2,436)	(2,475)	(2,475)	(1,806)	(2,377)
2 m	-	-	-	-	1763	1763	1763	1763	1364	1364	1244	1364	1193	1193	889	1171	1149	1149	751	994
(6' - 7")	-	-	-	-	(3,886)	(3,886)	(3,886)	(3,886)	(3,007)	(3,007)	(2,743)	(3,007)	(2,630)	(2,630)	(1,960)	(2,583)	(2,533)	(2,533)	(1,656)	(2,192)
1 m	-	-	-	-	2415	2415	1755	2387	1637	1637	1177	1569	1305	1305	858	1139	1186	1135	733	975
(3' - 3")	-	-	-	-	(5,324)	(5,324)	(3,870)	(5,264)	(3,609)	(3,609)	(2,596)	(3,460)	(2,877)	(2,877)	(1,891)	(2,512)	(2,615)	(2,502)	(1,616)	(2,149)
0 m	5110	5110	3105	4565	2709	2709	1677	2302	1805	1805	1131	1520	1361	1307	836	1116	1231	1186	762	1016
(0' - 0")	(11,268)	(11,268)	(6,848)	(10,065)	(5,972)	(5,972)	(3,697)	(5,076)	(3,980)	(3,980)	(2,494)	(3,352)	(3,000)	(2,881)	(1,842)	(2,461)	(2,714)	(2,614)	(1,679)	(2,240)
-1 m	4600	4600	3124	4586	2632	2632	1660	2284	1778	1778	1115	1504	-	-	-	-	1276	1276	857	1145
-(3' - 3")	(10,144)	(10,144)	(6,888)	(10,113)	(5,804)	(5,804)	(3,659)	(5,035)	(3,921)	(3,921)	(2,459)	(3,315)	-	-	-	-	(2,813)	(2,813)	(1,891)	(2,526)
-2 m	3576	3576	3190	3576	2163	2163	1688	2163	1374	1374	1142	1374	-	-	-	-	1294	1294	1111	1294
-(6' - 7")	(7,884)	(7,884)	(7,035)	(7,884)	(4,769)	(4,769)	(3,722)	(4,769)	(3,031)	(3,031)	(2,519)	(3,031)	-	-	-	-	(2,853)	(2,853)	(2,450)	(2,853)

**09: Mono boom/single tires/transport bar for clamshell bucket at front/parallel dozer blade at rear/short stick**

A B	2 m (6' - 7")				3 m (9' - 10")				4 m (13' - 1")				5 m (16' - 5")				max			
	I	II	III	IV	I	II	III	IV	I	II	III	IV	I	II	III	IV	I	II	III	IV
	4 m	-	-	-	-	-	-	-	-	1161	1161	1161	1161	-	-	-	-	1227	1227	1031
(13' - 1")	-	-	-	-	-	-	-	-	(2,560)	(2,560)	(2,560)	(2,560)	-	-	-	-	(2,706)	(2,706)	(2,273)	(2,618)
3 m	-	-	-	-	-	-	-	-	1252	1252	1219	1252	1226	1226	850	979	1229	1229	849	978
(9' - 10")	-	-	-	-	-	-	-	-	(2,761)	(2,761)	(2,689)	(2,761)	(2,703)	(2,703)	(1,875)	(2,159)	(2,710)	(2,710)	(1,873)	(2,157)
2 m	-	-	-	-	2010	2010	1761	2010	1490	1490	1161	1350	1281	1281	832	960	1255	1255	770	888
(6' - 7")	-	-	-	-	(4,433)	(4,433)	(3,884)	(4,433)	(3,285)	(3,285)	(2,560)	(2,976)	(2,825)	(2,825)	(1,834)	(2,116)	(2,768)	(2,768)	(1,698)	(1,959)
1 m	-	-	-	-	2576	2576	1630	1951	1728	1728	1101	1287	1362	1362	806	933	1295	1288	750	867
(3' - 3")	-	-	-	-	(5,679)	(5,679)	(3,595)	(4,303)	(3,810)	(3,810)	(2,428)	(2,837)	(3,004)	(3,004)	(1,778)	(2,058)	(2,855)	(2,841)	(1,654)	(1,911)
0 m	4853	4853	2942	3787	2743	2743	1574	1891	1841	1841	1064	1247	1361	1361	792	918	1343	1343	784	909
(0' - 0")	(10,701)	(10,701)	(6,486)	(8,350)	(6,048)	(6,048)	(3,471)	(4,169)	(4,060)	(4,060)	(2,347)	(2,751)	(3,001)	(3,001)	(1,747)	(2,025)	(2,961)	(2,961)	(1,730)	(2,005)
-1 m	4233	4233	2971	3821	2550	2550	1572	1888	1731	1731	1059	1242	-	-	-	-	1387	1387	902	1050
-(3' - 3")	(9,334)	(9,334)	(6,551)	(8,425)	(5,623)	(5,623)	(3,466)	(4,163)	(3,817)	(3,817)	(2,336)	(2,739)	-	-	-	-	(3,058)	(3,058)	(1,990)	(2,316)
-2 m	3019	3019	3019	3019	1904	1904	1616	1904	-	-	-	-	-	-	-	-	1375	1375	1251	1375
-(6' - 7")	(6,657)	(6,657)	(6,657)	(6,657)	(4,199)	(4,199)	(3,564)	(4,199)	-	-	-	-	-	-	-	-	(3,031)	(3,031)	(2,758)	(3,031)

**10: Mono boom/single tires/transport bar for clamshell bucket at front/parallel dozer blade at rear/long stick**

A B	2 m				3 m				4 m				5 m				max			
	(6' - 7'")				(9' - 10'")				(13' - 1'")				(16' - 5'")							
	I	II	III	IV	I	II	III	IV	I	II	III	IV	I	II	III	IV	I	II	III	IV
4 m	-	-	-	-	-	-	-	-	1001	1001	1001	1001	-	-	-	-	1114	1114	908	1045
(13' - 1'")	-	-	-	-	-	-	-	-	(2,208)	(2,208)	(2,208)	(2,208)	-	-	-	-	(2,457)	(2,457)	(2,001)	(2,304)
3 m	-	-	-	-	-	-	-	-	1113	1113	1113	1113	1105	1105	856	986	1122	1122	765	881
(9' - 10'")	-	-	-	-	-	-	-	-	(2,455)	(2,455)	(2,455)	(2,455)	(2,436)	(2,436)	(1,887)	(2,173)	(2,475)	(2,475)	(1,687)	(1,943)
2 m	-	-	-	-	1763	1763	1763	1763	1364	1364	1167	1358	1193	1193	830	959	1149	1149	699	807
(6' - 7'")	-	-	-	-	(3,886)	(3,886)	(3,886)	V	(3,007)	(3,007)	(2,574)	(2,993)	(2,630)	(2,630)	(1,831)	(2,114)	(2,533)	(2,533)	(1,542)	(1,780)
1 m	-	-	-	-	2415	2415	1644	1968	1637	1637	1101	1287	1305	1305	799	927	1186	1178	681	788
(3' - 3'")	-	-	-	-	(5,324)	(5,324)	(3,625)	(4,338)	(3,609)	(3,609)	(2,427)	(2,838)	(2,877)	(2,877)	(1,762)	(2,043)	(2,615)	(2,597)	(1,502)	(1,738)
0 m	5110	5110	2904	3746	2709	2709	1566	1883	1805	1805	1054	1238	1361	1356	777	903	1231	1231	708	821
(0' - 0'")	(11,268)	(11,268)	(6,403)	(8,259)	(5,972)	(5,972)	(3,452)	(4,151)	(3,980)	(3,980)	(2,325)	(2,730)	(3,000)	(2,991)	(1,714)	(1,992)	(2,714)	(2,714)	(1,560)	(1,810)
-1 m	4600	4600	2922	3767	2632	2632	1548	1864	1778	1778	1039	1222	-	-	-	-	1276	1276	798	928
(-3' - 3'")	(10,144)	(10,144)	(6,443)	(8,306)	(5,804)	(5,804)	(3,414)	(4,110)	(3,921)	(3,921)	(2,290)	(2,693)	-	-	-	-	(2,813)	(2,813)	(1,759)	(2,046)
-2 m	3576	3576	2989	3576	2163	2163	1577	1895	1374	1374	1066	1250	-	-	-	-	1294	1294	1036	1214
(-6' - 7'")	(7,884)	(7,884)	(6,590)	(7,884)	(4,769)	(4,769)	(3,478)	(4,178)	(3,031)	(3,031)	(2,350)	(2,756)	-	-	-	-	(2,853)	(2,853)	(2,285)	(2,676)

**11: Mono boom/single tires/parallel dozer blade at front/short stick**

A B	2 m				3 m				4 m				5 m				max			
	(6' - 7'")				(9' - 10'")				(13' - 1'")				(16' - 5'")							
	I	II	III	IV	I	II	III	IV	I	II	III	IV	I	II	III	IV	I	II	III	IV
4 m	-	-	-	-	-	-	-	-	1161	1161	1161	1161	-	-	-	-	1227	1227	1044	1227
(13' - 1'")	-	-	-	-	-	-	-	-	(2,560)	(2,560)	(2,560)	(2,560)	-	-	-	-	(2,706)	(2,706)	(2,302)	(2,706)
3 m	-	-	-	-	-	-	-	-	1252	1252	1235	1252	1226	1137	862	1226	1229	1135	861	1229
(9' - 10'")	-	-	-	-	-	-	-	-	(2,761)	(2,761)	(2,723)	(2,761)	(2,703)	(2,507)	(1,901)	(2,703)	(2,710)	(2,503)	(1,899)	(2,710)
2 m	-	-	-	-	2010	2010	1784	2010	1490	1490	1176	1490	1281	1116	844	1277	1255	1032	781	1187
(6' - 7'")	-	-	-	-	(4,433)	(4,433)	(3,933)	(4,433)	(3,285)	(3,285)	(2,594)	(3,285)	(2,825)	(2,462)	(1,860)	(2,815)	(2,768)	(2,275)	(1,723)	(2,617)
1 m	-	-	-	-	2576	2384	1653	2576	1728	1521	1117	1708	1362	1088	818	1250	1295	1009	761	1165
(3' - 3'")	-	-	-	-	(5,679)	(5,257)	(3,644)	(5,679)	(3,810)	(3,354)	(2,462)	(3,765)	(3,004)	(2,400)	(1,804)	(2,757)	(2,855)	(2,225)	(1,678)	(2,568)
0 m	4853	4853	2982	4853	2743	2317	1597	2517	1841	1479	1080	1668	1361	1073	804	1235	1343	1061	796	1223
(0' - 0'")	(10,701)	(10,701)	(6,576)	(10,701)	(6,048)	(5,109)	(3,521)	(5,549)	(4,060)	(3,261)	(2,381)	(3,679)	(3,001)	(2,365)	(1,773)	(2,724)	(2,961)	(2,340)	(1,755)	(2,697)
-1 m	4233	4233	3012	4233	2550	2314	1594	2514	1731	1473	1075	1663	-	-	-	-	1387	1233	916	1387
(-3' - 3'")	(9,334)	(9,334)	(6,641)	(9,334)	(5,623)	(5,103)	(3,516)	(5,544)	(3,817)	(3,249)	(2,370)	(3,667)	-	-	-	-	(3,058)	(2,719)	(2,019)	(3,058)
-2 m	3019	3019	3019	3019	1904	1904	1639	1904	-	-	-	-	-	-	-	-	1375	1375	1268	1375
(-6' - 7'")	(6,657)	(6,657)	(6,657)	(6,657)	(4,199)	(4,199)	(3,613)	(4,199)	-	-	-	-	-	-	-	-	(3,031)	(3,031)	(2,797)	(3,031)

**12: Mono boom/single tires/parallel dozer blade at front/long stick**

A B	2 m				3 m				4 m				5 m				max			
	(6' - 7'")				(9' - 10'")				(13' - 1'")				(16' - 5'")							
	I	II	III	IV	I	II	III	IV	I	II	III	IV	I	II	III	IV	I	II	III	IV
4 m	-	-	-	-	-	-	-	-	1001	1001	1001	1001	-	-	-	-	1114	1114	920	1114
(13' - 1'")	-	-	-	-	-	-	-	-	(2,208)	(2,208)	(2,208)	(2,208)	-	-	-	-	(2,457)	(2,457)	(2,028)	(2,457)
3 m	-	-	-	-	-	-	-	-	1113	1113	1113	1113	1105	1105	868	1105	1122	1023	776	1122
(9' - 10'")	-	-	-	-	-	-	-	-	(2,455)	(2,455)	(2,455)	(2,455)	(2,436)	(2,436)	(1,913)	(2,436)	(2,475)	(2,255)	(1,711)	(2,475)
2 m	-	-	-	-	1763	1763	1763	1763	1364	1364	1183	1364	1193	1116	842	1193	1149	938	710	1086
(6' - 7'")	-	-	-	-	(3,886)	(3,886)	(3,886)	(3,886)	(3,007)	(3,007)	(2,608)	(3,007)	(2,630)	(2,461)	(1,857)	(2,630)	(2,533)	(2,068)	(1,565)	(2,395)
1 m	-	-	-	-	2415	2404	1666	2415	1637	1523	1116	1637	1305	1082	811	1244	1186	918	692	1066
(3' - 3'")	-	-	-	-	(5,324)	(5,301)	(3,674)	(5,324)	(3,609)	(3,357)	(2,461)	(3,609)	(2,877)	(2,386)	(1,788)	(2,742)	(2,615)	(2,024)	(1,525)	(2,351)
0 m	5110	5110	2944	4968	2709	2310	1588	2509	1805	1470	1070	1659	1361	1058	789	1220	1231	958	718	1112
(0' - 0'")	(11,268)	(11,268)	(6,492)	(10,954)	(5,972)	(5,093)	(3,502)	(5,532)	(3,980)	(3,242)	(2,359)	(3,658)	(3,000)	(2,333)	(1,740)	(2,691)	(2,714)	(2,113)	(1,584)	(2,452)
-1 m	4600	4600	2963	4600	2632	2289	1571	2490	1778	1452	1054	1642	-	-	-	-	1276	1088	810	1253
(-3' - 3'")	(10,144)	(10,144)	(6,533)	(10,144)	(5,804)	(5,048)	(3,464)	(5,491)	(3,921)	(3,203)	(2,324)	(3,621)	-	-	-	-	(2,813)	(2,398)	(1,785)	(2,762)
-2 m	3576	3576	3029	3576	2163	2163	1599	2163	1374	1374	1081	1374	-	-	-	-	1294	1294	1051	1294
(-6' - 7'")	(7,884)	(7,884)	(6,680)	(7,884)	(4,769)	(4,769)	(3,527)	(4,769)	(3,031)	(3,031)	(2,384)	(3,031)	-	-	-	-	(2,853)	(2,853)	(2,319)	(2,853)

13: Mono boom/single tires/dozer blade at front/short stick

A B	2 m				3 m				4 m				5 m				max			
	(6' - 7'')				(9' - 10'')				(13' - 1'')				(16' - 5'')							
	I	II	III	IV	I	II	III	IV	I	II	III	IV	I	II	III	IV	I	II	III	IV
4 m	-	-	-	-	-	-	-	-	1161	1161	1161	1161	-	-	-	-	1227	1227	1023	1227
(13' - 1'')	-	-	-	-	-	-	-	-	(2,560)	(2,560)	(2,560)	(2,560)	-	-	-	-	(2,706)	(2,706)	(2,256)	(2,706)
3 m	-	-	-	-	-	-	-	-	1252	1252	1211	1252	1226	1155	844	1226	1229	1154	843	1225
(9' - 10'')	-	-	-	-	-	-	-	-	(2,761)	(2,761)	(2,670)	(2,761)	(2,703)	(2,548)	(1,861)	(2,703)	(2,710)	(2,544)	(1,859)	(2,702)
2 m	-	-	-	-	2010	2010	1749	2010	1490	1490	1152	1490	1281	1135	825	1207	1255	1049	764	1121
(6' - 7'')	-	-	-	-	(4,433)	(4,433)	(3,856)	(4,433)	(3,285)	(3,285)	(2,541)	(3,285)	(2,825)	(2,503)	(1,820)	(2,662)	(2,768)	(2,314)	(1,685)	(2,473)
1 m	-	-	-	-	2576	2423	1618	2440	1728	1546	1093	1615	1362	1107	800	1181	1295	1026	744	1099
(3' - 3'')	-	-	-	-	(5,679)	(5,343)	(3,568)	(5,381)	(3,810)	(3,409)	(2,410)	(3,562)	(3,004)	(2,441)	(1,764)	(2,603)	(2,855)	(2,263)	(1,640)	(2,424)
0 m	4853	4853	2919	4741	2743	2356	1562	2379	1841	1504	1056	1576	1361	1091	786	1166	1343	1080	778	1154
(0' - 0'')	10,701	10,701	(6,436)	10,454	(6,048)	(5,194)	(3,444)	(5,247)	(4,060)	(3,317)	(2,328)	(3,475)	(3,001)	(2,406)	(1,732)	(2,571)	(2,961)	(2,381)	(1,715)	(2,545)
-1 m	4233	4233	2948	4233	2550	2353	1560	2377	1731	1498	1051	1571	-	-	-	-	1387	1254	895	1329
-(3' - 3'')	(9,334)	(9,334)	(6,501)	(9,334)	(5,623)	(5,188)	(3,439)	(5,241)	(3,817)	(3,304)	(2,317)	(3,463)	-	-	-	-	(3,058)	(2,766)	(1,974)	(2,931)
-2 m	3019	3019	3019	3019	1904	1904	1604	1904	-	-	-	-	-	-	-	-	1375	1375	1241	1375
-(6' - 7'')	(6,657)	(6,657)	(6,657)	(6,657)	(4,199)	(4,199)	(3,536)	(4,199)	-	-	-	-	-	-	-	-	(3,031)	(3,031)	(2,737)	(3,031)

14: Mono boom/single tires/dozer blade at front/long stick

A B	2 m				3 m				4 m				5 m				max			
	(6' - 7'')				(9' - 10'')				(13' - 1'')				(16' - 5'')							
	I	II	III	IV	I	II	III	IV	I	II	III	IV	I	II	III	IV	I	II	III	IV
4 m	-	-	-	-	-	-	-	-	1001	1001	1001	1001	-	-	-	-	1114	1114	901	1114
(13' - 1'')	-	-	-	-	-	-	-	-	(2,208)	(2,208)	(2,208)	(2,208)	-	-	-	-	(2,457)	(2,457)	(1,986)	(2,457)
3 m	-	-	-	-	-	-	-	-	1113	1113	1113	1113	1105	1105	849	1105	1122	1040	759	1110
(9' - 10'')	-	-	-	-	-	-	-	-	(2,455)	(2,455)	(2,455)	(2,455)	(2,436)	(2,436)	(1,873)	(2,436)	(2,475)	(2,293)	(1,673)	(2,448)
2 m	-	-	-	-	1763	1763	1763	1763	1364	1364	1159	1364	1193	1135	824	1193	1149	954	694	1025
(6' - 7'')	-	-	-	-	(3,886)	(3,886)	(3,886)	(3,886)	(3,007)	(3,007)	(2,555)	(3,007)	(2,630)	(2,502)	(1,816)	(2,630)	(2,533)	(2,104)	(1,529)	(2,260)
1 m	-	-	-	-	2415	2415	1632	2415	1637	1548	1092	1616	1305	1101	793	1174	1186	934	675	1005
(3' - 3'')	-	-	-	-	(5,324)	(5,324)	(3,598)	(5,324)	(3,609)	(3,413)	(2,408)	(3,562)	(2,877)	(2,427)	(1,748)	(2,589)	(2,615)	(2,060)	(1,489)	(2,217)
0 m	5110	5110	2881	4700	2709	2349	1553	2371	1805	1495	1046	1567	1361	1077	771	1151	1231	975	702	1048
(0' - 0'')	11,268	11,268	(6,353)	10,363	(5,972)	(5,179)	(3,425)	(5,229)	(3,980)	(3,297)	(2,306)	(3,454)	(3,000)	(2,374)	(1,699)	(2,538)	(2,714)	(2,150)	(1,547)	(2,311)
-1 m	4600	4600	2900	4600	2632	2328	1536	2353	1778	1478	1030	1550	-	-	-	-	1276	1107	791	1181
-(3' - 3'')	(10,144)	(10,144)	(6,394)	(10,144)	(5,804)	(5,133)	(3,387)	(5,188)	(3,921)	(3,258)	(2,272)	(3,418)	-	-	-	-	(2,813)	(2,440)	(1,744)	(2,605)
-2 m	3576	3576	2966	3576	2163	2163	1565	2163	1374	1374	1057	1374	-	-	-	-	1294	1294	1028	1294
-(6' - 7'')	(7,884)	(7,884)	(6,541)	(7,884)	(4,769)	(4,769)	(3,450)	(4,769)	(3,031)	(3,031)	(2,331)	(3,031)	-	-	-	-	(2,853)	(2,853)	(2,267)	(2,853)

**15: One-piece boom/twin tires/stabilizer blade at rear/transport bar for clamshell bucket at front/short stick**

A B	2 m				3 m				4 m				5 m				max			
	(6' - 7'")				(9' - 10'")				(13' - 1'")				(16' - 5'")							
	I	II	III	IV	I	II	III	IV	I	II	III	IV	I	II	III	IV	I	II	III	IV
4 m	-	-	-	-	-	-	-	-	1161	1161	1161	1161	-	-	-	-	1227	1227	1113	1227
(13' - 1'")	-	-	-	-	-	-	-	-	(2,560)	(2,560)	(2,560)	(2,560)	-	-	-	-	(2,706)	(2,706)	(2,455)	(2,706)
3 m	-	-	-	-	-	-	-	-	1252	1252	1252	1252	1226	1226	921	1041	1229	1229	920	1039
(9' - 10'")	-	-	-	-	-	-	-	-	(2,761)	(2,761)	(2,761)	(2,761)	(2,703)	(2,703)	(2,031)	(2,295)	(2,710)	(2,710)	(2,028)	(2,292)
2 m	-	-	-	-	2010	2010	1914	2010	1490	1490	1258	1431	1281	1281	902	1021	1255	1255	836	946
(6' - 7'")	-	-	-	-	(4,433)	(4,433)	(4,220)	(4,433)	(3,285)	(3,285)	(2,773)	(3,156)	(2,825)	(2,825)	(1,989)	(2,252)	(2,768)	(2,768)	(1,844)	(2,086)
1 m	-	-	-	-	2576	2576	1780	2073	1728	1728	1197	1368	1362	1360	876	995	1295	1263	815	925
(3' - 3'")	-	-	-	-	(5,679)	(5,679)	(3,925)	(4,571)	(3,810)	(3,810)	(2,640)	(3,017)	(3,004)	(2,998)	(1,933)	(2,193)	(2,855)	(2,785)	(1,798)	(2,039)
0 m	4853	4853	3263	4024	2743	2743	1723	2012	1841	1841	1160	1329	1361	1344	862	980	1343	1330	854	970
(0' - 0'")	(10,701)	(10,701)	(7,196)	(8,873)	(6,048)	(6,048)	(3,799)	(4,437)	(4,060)	(4,060)	(2,557)	(2,931)	(3,001)	(2,964)	(1,901)	(2,161)	(2,961)	(2,933)	(1,882)	(2,139)
-1 m	4233	4233	3294	4058	2550	2550	1721	2010	1731	1731	1155	1324	-	-	-	-	1387	1387	982	1120
(-3' - 3'")	(9,334)	(9,334)	(7,263)	(8,949)	(5,623)	(5,623)	(3,794)	(4,431)	(3,817)	(3,817)	(2,546)	(2,919)	-	-	-	-	(3,058)	(3,058)	(2,166)	(2,469)
-2 m	3019	3019	3019	3019	1904	1904	1766	1904	-	-	-	-	-	-	-	-	1375	1375	1362	1375
(-6' - 7'")	(6,657)	(6,657)	(6,657)	(6,657)	(4,199)	(4,199)	(3,894)	(4,199)	-	-	-	-	-	-	-	-	(3,031)	(3,031)	(3,003)	(3,031)

**16: One-piece boom/twin tires/stabilizer blade at rear/transport bar for clamshell bucket at front/long stick**

A B	2 m				3 m				4 m				5 m				max			
	(6' - 7'")				(9' - 10'")				(13' - 1'")				(16' - 5'")							
	I	II	III	IV	I	II	III	IV	I	II	III	IV	I	II	III	IV	I	II	III	IV
4 m	-	-	-	-	-	-	-	-	1001	1001	1001	1001	-	-	-	-	1114	1114	982	1109
(13' - 1'")	-	-	-	-	-	-	-	-	(2,208)	(2,208)	(2,208)	(2,208)	-	-	-	-	(2,457)	(2,457)	(2,164)	(2,445)
3 m	-	-	-	-	-	-	-	-	1113	1113	1113	1113	1105	1105	927	1047	1122	1122	830	938
(9' - 10'")	-	-	-	-	-	-	-	-	(2,455)	(2,455)	(2,455)	(2,455)	(2,436)	(2,436)	(2,043)	(2,309)	(2,475)	(2,475)	(1,830)	(2,069)
2 m	-	-	-	-	1763	1763	1763	1763	1364	1364	1264	1364	1193	1193	901	1020	1149	1149	760	862
(6' - 7'")	-	-	-	-	(3,886)	(3,886)	(3,886)	(3,886)	(3,007)	(3,007)	(2,788)	(3,007)	(2,630)	(2,630)	(1,986)	(2,250)	(2,533)	(2,533)	(1,677)	(1,900)
1 m	-	-	-	-	2415	2415	1794	2089	1637	1637	1197	1369	1305	1305	870	988	1186	1186	742	842
(3' - 3'")	-	-	-	-	(5,324)	(5,324)	(3,957)	(4,606)	(3,609)	(3,609)	(2,639)	(3,018)	(2,877)	(2,877)	(1,917)	(2,179)	(2,615)	(2,545)	(1,636)	(1,857)
0 m	5110	5110	3225	3983	2709	2709	1715	2004	1805	1805	1150	1320	1361	1329	847	965	1231	1206	771	877
(0' - 0'")	(11,268)	(11,268)	(7,111)	(8,782)	(5,972)	(5,972)	(3,781)	(4,419)	(3,980)	(3,980)	(2,536)	(2,910)	(3,000)	(2,931)	(1,868)	(2,128)	(2,714)	(2,660)	(1,701)	(1,935)
-1 m	4600	4600	3244	4004	2632	2632	1697	1985	1778	1778	1134	1303	-	-	-	-	1276	1276	869	991
(-3' - 3'")	(10,144)	(10,144)	(7,153)	(8,829)	(5,804)	(5,804)	(3,742)	(4,378)	(3,921)	(3,921)	(2,501)	(2,874)	-	-	-	-	(2,813)	(2,813)	(1,917)	(2,185)
-2 m	3576	3576	3313	3576	2163	2163	1726	2017	1374	1374	1161	1332	-	-	-	-	1294	1294	1129	1293
(-6' - 7'")	(7,884)	(7,884)	(7,305)	(7,884)	(4,769)	(4,769)	(3,806)	(4,446)	(3,031)	(3,031)	(2,561)	(2,936)	-	-	-	-	(2,853)	(2,853)	(2,490)	(2,851)

**17: One-piece boom/twin tires/stabilizer legs at rear/transport bar for clamshell bucket at front/short stick**

A B	2 m				3 m				4 m				5 m				max			
	(6' - 7'")				(9' - 10'")				(13' - 1'")				(16' - 5'")							
	I	II	III	IV	I	II	III	IV	I	II	III	IV	I	II	III	IV	I	II	III	IV
4 m	-	-	-	-	-	-	-	-	1161	1161	1161	1161	-	-	-	-	1227	1227	1122	1227
(13' - 1'")	-	-	-	-	-	-	-	-	(2,560)	(2,560)	(2,560)	(2,560)	-	-	-	-	(2,706)	(2,706)	(2,473)	(2,706)
3 m	-	-	-	-	-	-	-	-	1252	1252	1252	1252	1226	1226	928	1039	1229	1229	927	1038
(9' - 10'")	-	-	-	-	-	-	-	-	(2,761)	(2,761)	(2,761)	(2,761)	(2,703)	(2,703)	(2,047)	(2,291)	(2,710)	(2,710)	(2,045)	(2,288)
2 m	-	-	-	-	2010	2010	1928	2010	1490	1490	1267	1429	1281	1281	910	1019	1255	1255	843	944
(6' - 7'")	-	-	-	-	(4,433)	(4,433)	(4,250)	(4,433)	(3,285)	(3,285)	(2,794)	(3,151)	(2,825)	(2,825)	(2,006)	(2,248)	(2,768)	(2,768)	(1,859)	(2,082)
1 m	-	-	-	-	2576	2576	1794	2069	1728	1728	1207	1366	1362	1362	884	992.8	1295	1284	822	923
(3' - 3'")	-	-	-	-	(5,679)	(5,679)	(3,956)	(4,562)	(3,810)	(3,810)	(2,661)	(3,012)	(3,004)	(3,004)	(1,949)	(2,189)	(2,855)	(2,831)	(1,813)	(2,035)
0 m	4853	4853	3289	4017	2743	2743	1737	2008	1841	1841	1169	1327	1361	1361	869	978	1343	1343	861	968
(0' - 0'")	(10,701)	(10,701)	(7,253)	(8,857)	(6,048)	(6,048)	(3,830)	(4,428)	(4,060)	(4,060)	(2,578)	(2,925)	(3,001)	(3,001)	(1,917)	(2,156)	(2,961)	(2,961)	(1,898)	(2,135)
-1 m	4233	4233	3320	4051	2550	2550	1735	2006	1731	1731	1164	1321	-	-	-	-	1387	1387	990	1117
(-3' - 3'")	(9,334)	(9,334)	(7,320)	(8,932)	(5,623)	(5,623)	(3,825)	(4,423)	(3,817)	(3,817)	(2,567)	(2,913)	-	-	-	-	(3,058)	(3,058)	(2,184)	(2,464)
-2 m	3019	3019	3019	3019	1904	1904	1780	1904	-	-	-	-	-	-	-	-	1375	1375	1373	1375
(-6' - 7'")	(6,657)	(6,657)	(6,657)	(6,657)	(4,199)	(4,199)	(3,924)	(4,199)	-	-	-	-	-	-	-	-	(3,031)	(3,031)	(3,027)	(3,031)

**18: One-piece boom/twin tires/stabilizer legs at rear/transport bar for clamshell bucket at front/long stick**

18	2 m				3 m				4 m				5 m				max			
	(6' - 7'")				(9' - 10'")				(13' - 1'")				(16' - 5'")							
	I	II	III	IV	I	II	III	IV	I	II	III	IV	I	II	III	IV	I	II	III	IV
4 m	-	-	-	-	-	-	-	-	1001	1001	1001	1001	-	-	-	-	1114	1114	989	1107
(13' - 1'")	-	-	-	-	-	-	-	-	(2,208)	(2,208)	(2,208)	(2,208)	-	-	-	-	(2,457)	(2,457)	(2,181)	(2,441)
3 m	-	-	-	-	-	-	-	-	1113	1113	1113	1113	1105	1105	934	1045	1122	1122	837	937
(9' - 10'")	-	-	-	-	-	-	-	-	(2,455)	(2,455)	(2,455)	(2,455)	(2,436)	(2,436)	(2,059)	(2,305)	(2,475)	(2,475)	(1,845)	(2,065)
2 m	-	-	-	-	1763	1763	1763	1763	1364	A	1274	1364	1193	1193	908,1	1018	1149	1149	767	860
(6' - 7'")	-	-	-	-	(3,886)	(3,886)	(3,886)	(3,886)	(3,007)	B	(2,809)	(3,007)	(2,630)	(2,630)	(2,002)	(2,246)	(2,533)	(2,533)	(1,691)	(1,896)
1 m	-	-	-	-	2415	2415	1808	2085	1637		1206	1366	1305	1305	877	986	1186	1174	749	841
(3' - 3'")	-	-	-	-	(5,324)	(5,324)	(3,987)	(4,598)	(3,609)		(2,660)	(3,012)	(2,877)	(2,877)	(1,933)	(2,175)	(2,615)	(2,588)	(1,650)	(1,854)
0 m	5110	5110	3251	3975	2709	2709	1729	2000	1805	1805	1160	1317	1361	1352	854	963	1231	1227	778	876
(0' - 0'")	11,268	11,268	(7,168)	(8,766)	(5,972)	(5,972)	(3,812)	(4,411)	(3,980)	(3,980)	(2,557)	(2,904)	(3,000)	(2,981)	(1,884)	(2,124)	(2,714)	(2,705)	(1,716)	(1,931)
-1 m	4600	4600	3270	3997	2632	2632	1711	1982	1778	1778	1144	1301	-	-	-	-	1276	1276	877	989
-(3' - 3'")	10,144	10,144	(7,210)	(8,813)	(5,804)	(5,804)	(3,773)	(4,370)	(3,921)	(3,921)	(2,522)	(2,868)	-	-	-	-	(2,813)	(2,813)	(1,934)	(2,181)
-2 m	3576	3576	3339	3576	2163	2163	1740	2013	1374	1374	1171	1329	-	-	-	-	1294	1294	1138	1290
-(6' - 7'")	(7,884)	(7,884)	(7,362)	(7,884)	(4,769)	(4,769)	(3,837)	(4,438)	(3,031)	(3,031)	(2,582)	(2,931)	-	-	-	-	(2,853)	(2,853)	(2,510)	(2,846)

**19: One-piece boom/twin tires/stabilizer legs at rear/parallel stabilizer blade at front/short stick**

A B	2 m				3 m				4 m				5 m				max			
	(6' - 7'")				(9' - 10'")				(13' - 1'")				(16' - 5'")							
	I	II	III	IV	I	II	III	IV	I	II	III	IV	I	II	III	IV	I	II	III	IV
4 m	-	-	-	-	-	-	-	-	1161	1161	1161	1161	-	-	-	-	1227	1227	1207	1227
(13' - 1'")	-	-	-	-	-	-	-	-	(2,560)	(2,560)	(2,560)	(2,560)	-	-	-	-	(2,706)	(2,706)	(2,662)	(2,706)
3 m	-	-	-	-	-	-	-	-	1252	1252	1252	1252	1226	1226	1003	1226	1229	1229	1002	1229
(9' - 10'")	-	-	-	-	-	-	-	-	(2,761)	(2,761)	(2,761)	(2,761)	(2,703)	(2,703)	(2,212)	(2,703)	(2,710)	(2,710)	(2,209)	(2,710)
2 m	-	-	-	-	2010	2010	2010	2010	1490	1490	1365	1490	1281	1281	984	1281	1255	1244	914	1192
(6' - 7'")	-	-	-	-	(4,433)	(4,433)	(4,433)	(4,433)	(3,285)	(3,285)	(3,011)	(3,285)	(2,825)	(2,825)	(2,170)	(2,825)	(2,768)	(2,743)	(2,014)	(2,629)
1 m	-	-	-	-	2576	2576	1937	2576	1728	1728	1305	1716	1362	1314	959	1256	1295	1220	893	1170
(3' - 3'")	-	-	-	-	(5,679)	(5,679)	(4,272)	(5,679)	(3,810)	(3,810)	(2,878)	(3,783)	(3,004)	(2,898)	(2,114)	(2,770)	(2,855)	(2,691)	(1,968)	(2,580)
0 m	4853	4853	3553	4853	2743	2743	1880	2529	1841	1784	1268	1676	1361	1299	944	1241	1343	1285	935	1229
(0' - 0'")	10,701	10,701	(7,835)	(10,701)	(6,048)	(6,048)	(4,146)	(5,575)	(4,060)	(3,934)	(2,795)	(3,696)	(3,001)	(2,863)	(2,082)	(2,737)	(2,961)	(2,833)	(2,062)	(2,710)
-1 m	4233	4233	3584	4233	2550	2550	1878	2526	1731	1731	1262	1671	-	-	-	-	1387	1387	1074	1387
-(3' - 3'")	(9,334)	(9,334)	(7,902)	(9,334)	(5,623)	(5,623)	(4,141)	(5,570)	(3,817)	(3,817)	(2,784)	(3,684)	-	-	-	-	(3,058)	(3,058)	(2,369)	(3,058)
-2 m	3019	3019	3019	3019	1904	1904	1904	1904	-	-	-	-	-	-	-	-	1375	1375	1375	1375
-(6' - 7'")	(6,657)	(6,657)	(6,657)	(6,657)	(4,199)	(4,199)	(4,199)	(4,199)	-	-	-	-	-	-	-	-	(3,031)	(3,031)	(3,031)	(3,031)

**20: One-piece boom/twin tires/stabilizer legs at rear/parallel stabilizer blade at front/long stick**

A B	2 m				3 m				4 m				5 m				max			
	(6' - 7'")				(9' - 10'")				(13' - 1'")				(16' - 5'")							
	I	II	III	IV	I	II	III	IV	I	II	III	IV	I	II	III	IV	I	II	III	IV
4 m	-	-	-	-	-	-	-	-	1001	1001	1001	1001	-	-	-	-	1114	1114	1067	1114
(13' - 1'")	-	-	-	-	-	-	-	-	(2,208)	(2,208)	(2,208)	(2,208)	-	-	-	-	(2,457)	(2,457)	(2,352)	(2,457)
3 m	-	-	-	-	-	-	-	-	1113	1113	1113	1113	1105	1105	1009	1105	1122	1122	906	1122
(9' - 10'")	-	-	-	-	-	-	-	-	(2,455)	(2,455)	(2,455)	(2,455)	(2,436)	(2,436)	(2,224)	(2,436)	(2,475)	(2,475)	(1,998)	(2,475)
2 m	-	-	-	-	1763	1763	1763	1763	1364	1364	1364	1364	1193	1193	983	1193	1149	1135	833	1091
(6' - 7'")	-	-	-	-	(3,886)	(3,886)	(3,886)	(3,886)	(3,007)	(3,007)	(3,007)	(3,007)	(2,630)	(2,630)	(2,167)	(2,630)	(2,533)	(2,503)	(1,836)	(2,406)
1 m	-	-	-	-	2415	2415	1952	2415	1637	1637	1305	1637	1305	1305	952	1250	1186	1115	814	1072
(3' - 3'")	-	-	-	-	(5,324)	(5,324)	(4,303)	(5,324)	(3,609)	(3,609)	(2,877)	(3,609)	(2,877)	(2,877)	(2,098)	(2,755)	(2,615)	(2,458)	(1,796)	(2,363)
0 m	5110	5110	3515	4991	2709	2709	1872	2521	1805	1775	1258	1667	1361	1284	929	1226	1231	1165	847	1117
(0' - 0'")	11,268	11,268	(7,750)	(11,005)	(5,972)	(5,972)	(4,127)	(5,558)	(3,980)	(3,914)	(2,773)	(3,675)	(3,000)	(2,831)	(2,049)	(2,704)	(2,714)	(2,568)	(1,868)	(2,464)
-1 m	4600	4600	3534	4600	2632	2632	1854	2502	1778	1757	1242	1650	-	-	-	-	1276	1276	953	1259
-(3' - 3'")	10,144	10,144	(7,792)	(10,144)	(5,804)	(5,804)	(4,089)	(5,517)	(3,921)	(3,875)	(2,738)	(3,639)	-	-	-	-	(2,813)	(2,813)	(2,102)	(2,775)
-2 m	3576	3576	3576	3576	2163	2163	1883	2163	1374	1374	1269	1374	-	-	-	-	1294	1294	1234	1294
-(6' - 7'")	(7,884)	(7,884)	(7,884)	(7,884)	(4,769)	(4,769)	(4,153)	(4,769)	(3,031)	(3,031)	(2,799)	(3,031)	-	-	-	-	(2,853)	(2,853)	(2,721)	(2,853)

**21: One-piece boom/twin tires/stabilizer legs at front/parallel stabilizer blade at rear/short stick**

A \ B	2 m (6' - 7")				3 m (9' - 10")				4 m (13' - 1")				5 m (16' - 5")				max			
	I	II	III	IV	I	II	III	IV	I	II	III	IV	I	II	III	IV	I	II	III	IV
4 m	-	-	-	-	-	-	-	-	1161	1161	1161	1161	-	-	-	-	1227	1227	1207	1227
(13' - 1")	-	-	-	-	-	-	-	-	(2,560)	(2,560)	(2,560)	(2,560)	-	-	-	-	(2,706)	(2,706)	(2,662)	(2,706)
3 m	-	-	-	-	-	-	-	-	1252	1252	1252	1252	1226	1226	1003	1226	1229	1229	1002	1229
(9' - 10")	-	-	-	-	-	-	-	-	(2,761)	(2,761)	(2,761)	(2,761)	(2,703)	(2,703)	(2,212)	(2,703)	(2,710)	(2,710)	(2,209)	(2,710)
2 m	-	-	-	-	2010	2010	2010	2010	1490	1490	1365	1490	1281	1281	984	1217	1255	1255	914	1130
(6' - 7")	-	-	-	-	(4,433)	(4,433)	(4,433)	(4,433)	(3,285)	(3,285)	(3,011)	(3,285)	(2,825)	(2,825)	(2,170)	(2,683)	(2,768)	(2,768)	(2,014)	(2,492)
1 m	-	-	-	-	2576	2576	1937	2459	1728	1728	1305	1628	1362	1362	959	1190	1295	1286	893	1108
(3' - 3")	-	-	-	-	(5,679)	(5,679)	(4,272)	(5,421)	(3,810)	(3,810)	(2,878)	(3,589)	(3,004)	(3,004)	(2,114)	(2,624)	(2,855)	(2,835)	(1,968)	(2,443)
0 m	4853	4853	3553	4777	2743	2743	1880	2398	1841	1841	1268	1588	1361	1361	944	1175	1343	1343	935	1163
(0' - 0")	(10,701)	(10,701)	(7,835)	(10,534)	(6,048)	(6,048)	(4,146)	(5,287)	(4,060)	(4,060)	(2,795)	(3,502)	(3,001)	(3,001)	(2,082)	(2,591)	(2,961)	(2,961)	(2,062)	(2,565)
-1 m	4233	4233	3584	4233	2550	2550	1878	2395	1731	1731	1262	1583	-	-	-	-	1387	1387	1074	1340
(-3' - 3")	(9,334)	(9,334)	(7,902)	(9,334)	(5,623)	(5,623)	(4,141)	(5,282)	(3,817)	(3,817)	(2,784)	(3,491)	-	-	-	-	(3,058)	(3,058)	(2,369)	(2,954)
-2 m	3019	3019	3019	3019	1904	1904	1904	1904	-	-	-	-	-	-	-	-	1375	1375	1375	1375
(-6' - 7")	(6,657)	(6,657)	(6,657)	(6,657)	(4,199)	(4,199)	(4,199)	(4,199)	-	-	-	-	-	-	-	-	(3,031)	(3,031)	(3,031)	(3,031)

**22: One-piece boom/twin tires/stabilizer legs at front/parallel stabilizer blade at rear/long stick**

A \ B	2 m (6' - 7")				3 m (9' - 10")				4 m (13' - 1")				5 m (16' - 5")				max			
	I	II	III	IV	I	II	III	IV	I	II	III	IV	I	II	III	IV	I	II	III	IV
4 m	-	-	-	-	-	-	-	-	1001	1001	1001	1001	-	-	-	-	1114	1114	1067	1114
(13' - 1")	-	-	-	-	-	-	-	-	(2,208)	(2,208)	(2,208)	(2,208)	-	-	-	-	(2,457)	(2,457)	(2,352)	(2,457)
3 m	-	-	-	-	-	-	-	-	1113	1113	1113	1113	1105	1105	1009	1105	1122	1122	906	1119
(9' - 10")	-	-	-	-	-	-	-	-	(2,455)	(2,455)	(2,455)	(2,455)	(2,436)	(2,436)	(2,224)	(2,436)	(2,475)	(2,475)	(1,998)	(2,467)
2 m	-	-	-	-	1763	1763	1763	1763	1364	1364	1364	1364	1193	1193	983	1193	1149	1149	833	1033
(6' - 7")	-	-	-	-	(3,886)	(3,886)	(3,886)	(3,886)	(3,007)	(3,007)	(3,007)	(3,007)	(2,630)	(2,630)	(2,167)	(2,630)	(2,533)	(2,533)	(1,836)	(2,278)
1 m	-	-	-	-	2415	2415	1952	2415	1637	1637	1305	1628	1305	1305	952	1183	1186	1175	814	1014
(3' - 3")	-	-	-	-	(5,324)	(5,324)	(4,303)	(5,324)	(3,609)	(3,609)	(2,877)	(3,590)	(2,877)	(2,877)	(2,098)	(2,609)	(2,615)	(2,592)	(1,796)	(2,235)
0 m	5110	5110	3515	4736	2709	2709	1872	2390	1805	1805	1258	1579	1361	1353	929	1160	1231	1228	847	1057
(0' - 0")	(11,268)	(11,268)	(7,750)	(10,443)	(5,972)	(5,972)	(4,127)	(5,270)	(3,980)	(3,980)	(2,773)	(3,482)	(3,000)	(2,984)	(2,049)	(2,558)	(2,714)	(2,708)	(1,868)	(2,330)
-1 m	4600	4600	3534	4600	2632	2632	1854	2371	1778	1778	1242	1562	-	-	-	-	1276	1276	953	1191
(-3' - 3")	(10,144)	(10,144)	(7,792)	(10,144)	(5,804)	(5,804)	(4,089)	(5,228)	(3,921)	(3,921)	(2,738)	(3,445)	-	-	-	-	(2,813)	(2,813)	(2,102)	(2,626)
-2 m	3576	3576	3576	3576	2163	2163	1883	2163	1374	1374	1269	1374	-	-	-	-	1294	1294	1234	1294
(-6' - 7")	(7,884)	(7,884)	(7,884)	(7,884)	(4,769)	(4,769)	(4,153)	(4,769)	(3,031)	(3,031)	(2,799)	(3,031)	-	-	-	-	(2,853)	(2,853)	(2,721)	(2,853)

**23: One-piece boom/twin tires/transport bar for clamshell bucket at front/parallel stabilizer blade at rear/short stick**

A \ B	2 m (6' - 7")				3 m (9' - 10")				4 m (13' - 1")				5 m (16' - 5")				max			
	I	II	III	IV	I	II	III	IV	I	II	III	IV	I	II	III	IV	I	II	III	IV
4 m	-	-	-	-	-	-	-	-	1161	1161	1161	1161	-	-	-	-	1227	1227	1136	1227
(13' - 1")	-	-	-	-	-	-	-	-	(2,560)	(2,560)	(2,560)	(2,560)	-	-	-	-	(2,706)	(2,706)	(2,505)	(2,706)
3 m	-	-	-	-	-	-	-	-	1252	1252	1252	1252	1226	1226	941	1024	1229	1229	940	1022
(9' - 10")	-	-	-	-	-	-	-	-	(2,761)	(2,761)	(2,761)	(2,761)	(2,703)	(2,703)	(2,075)	(2,257)	(2,710)	(2,710)	(2,072)	(2,254)
2 m	-	-	-	-	2010	2010	1952	2010	1490	1490	1284	1409	1281	1281	922	1004	1255	1255	855	930
(6' - 7")	-	-	-	-	(4,433)	(4,433)	(4,304)	(4,433)	(3,285)	(3,285)	(2,831)	(3,106)	(2,825)	(2,825)	(2,033)	(2,214)	(2,768)	(2,768)	(1,885)	(2,051)
1 m	-	-	-	-	2576	2576	1818	2039	1728	1728	1223	1346	1362	1362	896	978	1295	1295	834	908
(3' - 3")	-	-	-	-	(5,679)	(5,679)	(4,009)	(4,496)	(3,810)	(3,810)	(2,698)	(2,967)	(3,004)	(3,004)	(1,977)	(2,156)	(2,855)	(2,855)	(1,839)	(2,003)
0 m	4853	4853	3334	3958	2743	2743	1761	1978	1841	1841	1186	1306	1361	1361	882	963	1343	1343	873	953
(0' - 0")	(10,701)	(10,701)	(7,351)	(8,727)	(6,048)	(6,048)	(3,883)	(4,362)	(4,060)	(4,060)	(2,615)	(2,881)	(3,001)	(3,001)	(1,945)	(2,123)	(2,961)	(2,961)	(1,926)	(2,101)
-1 m	4233	4233	3364	3992	2550	2550	1759	1976	1731	1731	1181	1301	-	-	-	-	1387	1387	1005	1100
(-3' - 3")	(9,334)	(9,334)	(7,418)	(8,802)	(5,623)	(5,623)	(3,878)	(4,356)	(3,817)	(3,817)	(2,603)	(2,869)	-	-	-	-	(3,058)	(3,058)	(2,215)	(2,426)
-2 m	3019	3019	3019	3019	1904	1904	1804	1904	-	-	-	-	-	-	-	-	1375	1375	1375	1375
(-6' - 7")	(6,657)	(6,657)	(6,657)	(6,657)	(4,199)	(4,199)	(3,978)	(4,199)	-	-	-	-	-	-	-	-	(3,031)	(3,031)	(3,031)	(3,031)

**24: One-piece boom/twin tires/transport bar for clamshell bucket at front/parallel stabilizer blade at rear/long stick**

A B	2 m				3 m				4 m				5 m				max			
	(6' - 7'')				(9' - 10'')				(13' - 1'')				(16' - 5'')							
	I	II	III	IV	I	II	III	IV	I	II	III	IV	I	II	III	IV	I	II	III	IV
4 m	-	-	-	-	-	-	-	-	1001	1001	1001	1001	-	-	-	-	1114	1114	1002	1091
(13' - 1'')	-	-	-	-	-	-	-	-	(2,208)	(2,208)	(2,208)	(2,208)	-	-	-	-	(2,457)	(2,457)	(2,210)	(2,406)
3 m	-	-	-	-	-	-	-	-	1113	1113	1113	1113	1105	1105	947	1030	1122	1122	848	922
(9' - 10'')	-	-	-	-	-	-	-	-	(2,455)	(2,455)	(2,455)	(2,455)	(2,436)	(2,436)	(2,087)	(2,271)	(2,475)	(2,475)	(1,870)	(2,034)
2 m	-	-	-	-	1763	1763	1763	1763	1364	1364	1291	1364	1193	1193	921	1003	1149	1149	778	846
(6' - 7'')	-	-	-	-	(3,886)	(3,886)	(3,886)	(3,886)	(3,007)	(3,007)	(2,846)	(3,007)	(2,630)	(2,630)	(2,030)	(2,212)	(2,533)	(2,533)	(1,715)	(1,866)
1 m	-	-	-	-	2415	2415	1832	2055	1637	1637	1223	1346	1305	1305	889	971	1186	1186	760	827
(3' - 3'')	-	-	-	-	(5,324)	(5,324)	(4,041)	(4,532)	(3,609)	(3,609)	(2,697)	(2,968)	(2,877)	(2,877)	(1,961)	(2,141)	(2,615)	(2,615)	(1,675)	(1,824)
0 m	5110	5110	3295	3917	2709	2709	1753	1970	1805	1805	1176	1297	1361	1361	867	948	1231	1231	790	862
(0' - 0'')	11,268	11,268	(7,266)	(8,636)	(5,972)	(5,972)	(3,865)	(4,344)	(3,980)	(3,980)	(2,593)	(2,860)	(3,000)	(3,000)	(1,912)	(2,090)	(2,714)	(2,714)	(1,741)	(1,900)
-1 m	4600	4600	3314	3938	2632	2632	1735	1952	1778	1778	1160	1280	-	-	-	-	1276	1276	890	973
-(3' - 3'')	10,144	10,144	(7,308)	(8,683)	(5,804)	(5,804)	(3,826)	(4,303)	(3,921)	(3,921)	(2,558)	(2,823)	-	-	-	-	(2,813)	(2,813)	(1,962)	(2,146)
-2 m	3576	3576	3383	3576	2163	2163	1764	1983	1374	1374	1187	1309	-	-	-	-	1294	1294	1154	1271
-(6' - 7'')	(7,884)	(7,884)	(7,460)	(7,884)	(4,769)	(4,769)	(3,890)	(4,372)	(3,031)	(3,031)	(2,618)	(2,886)	-	-	-	-	(2,853)	(2,853)	(2,546)	(2,802)

**25: One-piece boom/twin tires/parallel stabilizer blade at front/short stick**

A B	2 m				3 m				4 m				5 m				max			
	(6' - 7'')				(9' - 10'')				(13' - 1'')				(16' - 5'')							
	I	II	III	IV	I	II	III	IV	I	II	III	IV	I	II	III	IV	I	II	III	IV
4 m	-	-	-	-	-	-	-	-	1161	1161	1161	1161	-	-	-	-	1227	1227	1150	1227
(13' - 1'')	-	-	-	-	-	-	-	-	(2,560)	(2,560)	(2,560)	(2,560)	-	-	-	-	(2,706)	(2,706)	(2,537)	(2,706)
3 m	-	-	-	-	-	-	-	-	1252	1252	1252	1252	1226	1183	953	1226	1229	1182	952	1229
(9' - 10'')	-	-	-	-	-	-	-	-	(2,761)	(2,761)	(2,761)	(2,761)	(2,703)	(2,609)	(2,102)	(2,703)	(2,710)	(2,606)	(2,100)	(2,710)
2 m	-	-	-	-	2010	2010	1976	2010	1490	1490	1300	1490	1281	1163	935	1281	1255	1076	867	1229
(6' - 7'')	-	-	-	-	(4,433)	(4,433)	(4,357)	(4,433)	(3,285)	(3,285)	(2,867)	(3,285)	(2,825)	(2,564)	(2,061)	(2,825)	(2,768)	(2,372)	(1,911)	(2,709)
1 m	-	-	-	-	2576	2481	1842	2576	1728	1584	1240	1728	1362	1135	909	1294	1295	1053	846	1206
(3' - 3'')	-	-	-	-	(5,679)	(5,471)	(4,062)	(5,679)	(3,810)	(3,493)	(2,734)	(3,810)	(3,004)	(2,503)	(2,004)	(2,854)	(2,855)	(2,321)	(1,865)	(2,660)
0 m	4853	4853	3378	4853	2743	2414	1785	2604	1841	1542	1202	1727	1361	1119	895	1280	1343	1108	886	1267
(0' - 0'')	10,701	10,701	(7,448)	10,701	(6,048)	(5,323)	(3,936)	(5,742)	(4,060)	(3,400)	(2,651)	(3,808)	(3,001)	(2,468)	(1,972)	(2,822)	(2,961)	(2,442)	(1,953)	(2,794)
-1 m	4233	4233	3408	4233	2550	2411	1783	2550	1731	1536	1197	1722	-	-	-	-	1387	1286	1019	1387
-(3' - 3'')	(9,334)	(9,334)	(7,515)	(9,334)	(5,623)	(5,317)	(3,931)	(5,623)	(3,817)	(3,388)	(2,640)	(3,797)	-	-	-	-	(3,058)	(2,836)	(2,246)	(3,058)
-2 m	3019	3019	3019	3019	1904	1904	1828	1904	-	-	-	-	-	-	-	-	1375	1375	1375	1375
-(6' - 7'')	(6,657)	(6,657)	(6,657)	(6,657)	(4,199)	(4,199)	(4,030)	(4,199)	-	-	-	-	-	-	-	-	(3,031)	(3,031)	(3,031)	(3,031)

**26: One-piece boom/twin tires/parallel stabilizer blade at front/long stick**

A B	2 m				3 m				4 m				5 m				max			
	(6' - 7'')				(9' - 10'')				(13' - 1'')				(16' - 5'')							
	I	II	III	IV	I	II	III	IV	I	II	III	IV	I	II	III	IV	I	II	III	IV
4 m	-	-	-	-	-	-	-	-	1001	1001	1001	1001	-	-	-	-	1114	1114	1015	1114
(13' - 1'')	-	-	-	-	-	-	-	-	(2,208)	(2,208)	(2,208)	(2,208)	-	-	-	-	(2,457)	(2,457)	(2,239)	(2,457)
3 m	-	-	-	-	-	-	-	-	1113	1113	1113	1113	1105	1105	959	1105	1122	1066	860	1122
(9' - 10'')	-	-	-	-	-	-	-	-	(2,455)	(2,455)	(2,455)	(2,455)	(2,436)	(2,436)	(2,115)	(2,436)	(2,475)	(2,350)	(1,896)	(2,475)
2 m	-	-	-	-	1763	1763	1763	1763	1364	1364	1307	1364	1193	1163	933	1193	1149	979	789	1125
(6' - 7'')	-	-	-	-	(3,886)	(3,886)	(3,886)	(3,886)	(3,007)	(3,007)	(2,882)	(3,007)	(2,630)	(2,564)	(2,058)	(2,630)	(2,533)	(2,158)	(1,740)	(2,481)
1 m	-	-	-	-	2415	2415	1856	2415	1637	1586	1239	1637	1305	1129	902	1288	1186	958	771	1105
(3' - 3'')	-	-	-	-	(5,324)	(5,324)	(4,093)	(5,324)	(3,609)	(3,496)	(2,733)	(3,609)	(2,877)	(2,489)	(1,989)	(2,840)	(2,615)	(2,113)	(1,699)	(2,437)
0 m	5110	5110	3339	5110	2709	2407	1777	2596	1805	1533	1193	1718	1361	1105	880	1265	1231	1001	801	1153
(0' - 0'')	11,268	11,268	(7,363)	11,268	(5,972)	(5,307)	(3,918)	(5,725)	(3,980)	(3,381)	(2,629)	(3,788)	(3,000)	(2,436)	(1,939)	(2,789)	(2,714)	(2,207)	(1,767)	(2,541)
-1 m	4600	4600	3358	4600	2632	2386	1759	2578	1778	1515	1177	1701	-	-	-	-	1276	1135	903	1276
-(3' - 3'')	10,144	10,144	(7,405)	10,144	(5,804)	(5,262)	(3,879)	(5,684)	(3,921)	(3,342)	(2,595)	(3,751)	-	-	-	-	(2,813)	(2,504)	(1,990)	(2,813)
-2 m	3576	3576	3427	3576	2163	2163	1788	2163	1374	1374	1204	1374	-	-	-	-	1294	1294	1170	1294
-(6' - 7'')	(7,884)	(7,884)	(7,557)	(7,884)	(4,769)	(4,769)	(3,943)	(4,769)	(3,031)	(3,031)	(2,655)	(3,031)	-	-	-	-	(2,853)	(2,853)	(2,581)	(2,853)

**27: One-piece boom/twin tires/stabilizer blade at front/short stick**

A B	2 m (6' - 7")				3 m (9' - 10")				4 m (13' - 1")				5 m (16' - 5")				max			
	I	II	III	IV	I	II	III	IV	I	II	III	IV	I	II	III	IV	I	II	III	IV
4 m (13' - 1")	-	-	-	-	-	-	-	-	1161	1161	1161	1161	-	-	-	-	1227	1227	1128	1227
3 m (9' - 10")	-	-	-	-	-	-	-	-	1252	1252	1252	1252	1226	1202	934	1226	1229	1201	933	1229
2 m (6' - 7")	-	-	-	-	2010	2010	1938	2010	1490	1490	1275	1490	1281	1182	915	1252	1255	1093	848	1163
1 m (3' - 3")	-	-	-	-	(4,433)	(4,433)	(4,274)	(4,433)	(3,285)	(3,285)	(2,810)	(3,285)	(2,825)	(2,605)	(2,018)	(2,760)	(2,768)	(2,410)	(1,870)	(2,565)
0 m (0' - 0")	-	-	-	-	2576	2520	1805	2528	1728	1609	1214	1674	1362	1154	889	1225	1295	1070	828	1141
-1 m (-3' - 3")	-	-	-	-	(5,679)	(5,557)	(3,980)	(5,574)	(3,810)	(3,548)	(2,677)	(3,691)	(3,004)	(2,544)	(1,961)	(2,701)	(2,855)	(2,359)	(1,825)	(2,516)
-2 m (-6' - 7")	4853	4853	3309	4853	2743	2453	1748	2467	1841	1567	1177	1635	1361	1138	875	1210	1343	1126	866	1198
	(10,701)	(10,701)	(7,296)	(10,701)	(6,048)	(5,408)	(3,854)	(5,440)	(4,060)	(3,456)	(2,595)	(3,605)	(3,001)	(2,509)	(1,930)	(2,668)	(2,961)	(2,483)	(1,911)	(2,642)
	4233	4233	3339	4233	2550	2450	1746	2464	1731	1561	1172	1630	-	-	-	-	1387	1307	997	1379
	(9,334)	(9,334)	(7,363)	(9,334)	(5,623)	(5,402)	(3,849)	(5,434)	(3,817)	(3,443)	(2,583)	(3,593)	-	-	-	-	(3,058)	(2,882)	(2,198)	(3,041)
	3019	3019	3019	3019	1904	1904	1791	1904	-	-	-	-	-	-	-	-	1375	1375	1375	1375
	(6,657)	(6,657)	(6,657)	(6,657)	(4,199)	(4,199)	(3,948)	(4,199)	-	-	-	-	-	-	-	-	(3,031)	(3,031)	(3,031)	(3,031)

**28: One-piece boom/twin tires/stabilizer blade at front/long stick**

A B	2 m (6' - 7")				3 m (9' - 10")				4 m (13' - 1")				5 m (16' - 5")				max			
	I	II	III	IV	I	II	III	IV	I	II	III	IV	I	II	III	IV	I	II	III	IV
4 m (13' - 1")	-	-	-	-	-	-	-	-	1001	1001	1001	1001	-	-	-	-	1114	1114	995	1114
3 m (9' - 10")	-	-	-	-	-	-	-	-	1113	1113	1113	1113	1105	1105	940	1105	1122	1083	842	1122
2 m (6' - 7")	-	-	-	-	1763	1763	1763	1763	1364	1364	1281	1364	1193	1181	914	1193	1149	995	772	1064
1 m (3' - 3")	-	-	-	-	(3,886)	(3,886)	(3,886)	(3,886)	(3,007)	(3,007)	(2,826)	(3,007)	(2,630)	(2,605)	(2,015)	(2,630)	(2,533)	(2,194)	(1,702)	(2,346)
0 m (0' - 0")	-	-	-	-	2415	2415	1819	2415	1637	1611	1214	1637	1305	1148	882	1218	1186	975	753	1044
-1 m (-3' - 3")	-	-	-	-	(5,324)	(5,324)	(4,011)	(5,324)	(3,609)	(3,552)	(2,676)	(3,609)	(2,877)	(2,530)	(1,946)	(2,687)	(2,615)	(2,149)	(1,661)	(2,303)
-2 m (-6' - 7")	5110	5110	3270	4871	2709	2446	1739	2459	1805	1558	1167	1625	1361	1123	860	1195	1231	1018	783	1089
	(11,268)	(11,268)	(7,211)	(10,740)	(5,972)	(5,393)	(3,835)	(5,422)	(3,980)	(3,436)	(2,573)	(3,584)	(3,000)	(2,477)	(1,896)	(2,635)	(2,714)	(2,244)	(1,727)	(2,401)
	4600	4600	3290	4600	2632	2425	1722	2440	1778	1541	1151	1609	-	-	-	-	1276	1155	883	1227
	(10,144)	(10,144)	(7,253)	(10,144)	(5,804)	(5,347)	(3,797)	(5,381)	(3,921)	(3,397)	(2,538)	(3,548)	-	-	-	-	(2,813)	(2,546)	(1,946)	(2,705)
	3576	3576	3358	3576	2163	2163	1751	2163	1374	1374	1178	1374	-	-	-	-	1294	1294	1146	1294
	(7,884)	(7,884)	(7,405)	(7,884)	(4,769)	(4,769)	(3,861)	(4,769)	(3,031)	(3,031)	(2,598)	(3,031)	-	-	-	-	(2,853)	(2,853)	(2,526)	(2,853)

**29: Triple boom/single tires/dozer blade at rear/transport bar for clamshell bucket at front/short stick**

A B	2 m				3 m				4 m				5 m				max			
	(6' - 7'")				(9' - 10'")				(13' - 1'")				(16' - 5'")							
	I	II	III	IV	I	II	III	IV	I	II	III	IV	I	II	III	IV	I	II	III	IV
4 m	-	-	-	-	-	-	-	-	1240	1240	1186	1240	-	-	-	-	1190	1190	813	988
(13' - 1'")	-	-	-	-	-	-	-	-	(2,735)	(2,735)	(2,615)	(2,735)	-	-	-	-	(2,623)	(2,623)	(1,793)	(2,178)
3 m	-	-	-	-	1721	1721	1721	1721	1360	1360	1132	1360	1181	1181	782	951	1141	1141	677	828
(9' - 10'")	-	-	-	-	(3,794)	(3,794)	(3,794)	(3,794)	(2,999)	(2,999)	(2,496)	(2,999)	(2,603)	(2,603)	(1,723)	(2,097)	(2,516)	(2,516)	(1,493)	(1,825)
2 m	3234	3234	3196	3234	2260	2260	1575	1978	1554	1554	1048	1288	1242	1242	746	914	1118	1065	613	754
(6' - 7'")	(7,130)	(7,130)	(7,047)	(7,130)	(4,984)	(4,984)	(3,474)	(4,362)	(3,426)	(3,426)	(2,310)	(2,841)	(2,740)	(2,740)	(1,646)	(2,016)	(2,465)	(2,347)	(1,352)	(1,663)
1 m	4961	4961	2737	3717	2571	2571	1420	1809	1703	1703	970	1206	1291	1243	709	876	1102	1043	594	734
(3' - 3'")	10,940	10,940	(6,035)	(8,197)	(5,668)	(5,668)	(3,131)	(3,990)	(3,756)	(3,756)	(2,139)	(2,659)	(2,847)	(2,740)	(1,563)	(1,931)	(2,431)	(2,299)	(1,310)	(1,618)
0 m	4088	4088	2636	3599	2488	2488	1371	1756	1712	1675	926	1159	1259	1217	686	852	968	968	616	763
(0' - 0'")	(9,015)	(9,015)	(5,812)	(7,936)	(5,486)	(5,486)	(3,023)	(3,873)	(3,775)	(3,694)	(2,042)	(2,557)	(2,775)	(2,684)	(1,513)	(1,878)	(2,134)	(2,134)	(1,359)	(1,683)
-1 m	3040	3040	2663	3040	2148	2148	1378	1763	1528	1528	919	1153	-	-	-	-	1027	1027	697	864
-(3' - 3'")	(6,702)	(6,702)	(5,873)	(6,702)	(4,737)	(4,737)	(3,037)	(3,888)	(3,369)	(3,369)	(2,027)	(2,541)	-	-	-	-	(2,265)	(2,265)	(1,538)	(1,906)
-2 m	2764	2764	2528	2764	1506	1506	1427	1506	1003	1003	960,3	1003	-	-	-	-	869	869	869	869
-(6' - 7'")	(6,094)	(6,094)	(5,575)	(6,094)	(3,320)	(3,320)	(3,146)	(3,320)	(2,212)	(2,212)	(2,118)	(2,212)	-	-	-	-	(1,915)	(1,915)	(1,915)	(1,915)

**30: Triple boom/single tires/dozer blade at rear/transport bar for clamshell bucket at front/long stick**

A B	2 m				3 m				4 m				5 m				max			
	(6' - 7'")				(9' - 10'")				(13' - 1'")				(16' - 5'")							
	I	II	III	IV	I	II	III	IV	I	II	III	IV	I	II	III	IV	I	II	III	IV
4 m	-	-	-	-	-	-	-	-	1125	1125	1125	1125	1079	1079	805,9	977,3	1083	1083	726	885
(13' - 1'")	-	-	-	-	-	-	-	-	(2,480)	(2,480)	(2,480)	(2,480)	(2,380)	(2,380)	(1,777)	(2,155)	(2,388)	(2,388)	(1,602)	(1,950)
3 m	-	-	-	-	1523	1523	1523	1523	1255	1255	1148	1255	1106	1106	788	959	1047	1047	614	753
(9' - 10'")	-	-	-	-	(3,358)	(3,358)	(3,358)	(3,358)	(2,767)	(2,767)	(2,532)	(2,767)	(2,439)	(2,439)	(1,737)	(2,114)	(2,310)	(2,310)	(1,355)	(1,661)
2 m	2823	2823	2823	2823	2078	2078	1622	2030	1466	1466	1060	1302	1186	1186	747	916	1031	980	559	690
(6' - 7'")	(6,225)	(6,225)	(6,225)	(6,225)	(4,582)	(4,582)	(3,576)	(4,477)	(3,232)	(3,232)	(2,337)	(2,871)	(2,616)	(2,616)	(1,648)	(2,021)	(2,272)	(2,161)	(1,232)	(1,522)
1 m	4770	4770	2738	3721	2496	2496	1438	1830	1650	1650	973	1210	1259	1239	704	871	1020	960	541	671
(3' - 3'")	10,518	10,518	(6,038)	(8,206)	(5,503)	(5,503)	(3,170)	(4,036)	(3,639)	(3,639)	(2,145)	(2,668)	(2,775)	(2,732)	(1,553)	(1,921)	(2,250)	(2,116)	(1,192)	(1,480)
0 m	4330	4330	2566	3521	2531	2531	1360	1746	1708	1667	917	1151	1265	1205	674	839	1006	995	557	694
(0' - 0'")	(9,547)	(9,547)	(5,659)	(7,764)	(5,581)	(5,581)	(2,998)	(3,849)	(3,765)	(3,676)	(2,021)	(2,537)	(2,788)	(2,658)	(1,485)	(1,851)	(2,219)	(2,194)	(1,229)	(1,530)
-1 m	3538	3538	2596	3538	2275	2275	1350	1735	1587	1587	899	1132	1128	1128	667,3	832,7	971	971	621	773
-(3' - 3'")	(7,801)	(7,801)	(5,723)	(7,801)	(5,017)	(5,017)	(2,977)	(3,826)	(3,500)	(3,500)	(1,983)	(2,496)	(2,488)	(2,488)	(1,471)	(1,836)	(2,141)	(2,141)	(1,369)	(1,704)
-2 m	2509	2509	2509	2509	1737	1737	1385	1737	1207	1207	921,9	1156	-	-	-	-	869	869	779	869
-(6' - 7'")	(5,533)	(5,533)	(5,533)	(5,533)	(3,830)	(3,830)	(3,055)	(3,830)	(2,661)	(2,661)	(2,033)	(2,549)	-	-	-	-	(1,915)	(1,915)	(1,718)	(1,915)

**31: Triple boom/single tires/stabilizer legs at rear/transport bar for clamshell bucket at front/short stick**

A B	2 m				3 m				4 m				5 m				max			
	(6' - 7'")				(9' - 10'")				(13' - 1'")				(16' - 5'")							
	I	II	III	IV	I	II	III	IV	I	II	III	IV	I	II	III	IV	I	II	III	IV
4 m	-	-	-	-	-	-	-	-	1240	1240	1195	1240	-	-	-	-	1190	1190	820	986
(13' - 1'")	-	-	-	-	-	-	-	-	(2,735)	(2,735)	(2,635)	(2,735)	-	-	-	-	(2,623)	(2,623)	(1,809)	(2,174)
3 m	-	-	-	-	1721	1721	1721	1721	1360	1360	1141	1360	1181	1181	788	949	1141	1141	684	826
(9' - 10'")	-	-	-	-	(3,794)	(3,794)	(3,794)	(3,794)	(2,999)	(2,999)	(2,516)	(2,999)	(2,603)	(2,603)	(1,738)	(2,093)	(2,516)	(2,516)	(1,507)	(1,821)
2 m	3234	3234	3220	3234	2260	2260	1588	1974	1554	1554	1057	1286	1242	1242	753	912	1118	1084	619	752
(6' - 7'")	(7,130)	(7,130)	(7,099)	(7,130)	(4,984)	(4,984)	(3,503)	(4,354)	(3,426)	(3,426)	(2,330)	(2,835)	(2,740)	(2,740)	(1,661)	(2,012)	(2,465)	(2,390)	(1,365)	(1,659)
1 m	4961	4961	2761	3710	2571	2571	1433	1806	1703	1703	979	1204	1291	1265	716	874	1102	1062	600	732
(3' - 3'")	10,940	10,940	(6,088)	(8,180)	(5,668)	(5,668)	(3,159)	(3,981)	(3,756)	(3,756)	(2,159)	(2,654)	(2,847)	(2,790)	(1,579)	(1,926)	(2,431)	(2,342)	(1,323)	(1,614)
0 m	4088	4088	2660	3592	2488	2488	1384	1753	1712	1706	935	1157	1259	1240	693	850	968	968	623	762
(0' - 0'")	(9,015)	(9,015)	(5,865)	(7,920)	(5,486)	(5,486)	(3,052)	(3,864)	(3,775)	(3,761)	(2,062)	(2,551)	(2,775)	(2,734)	(1,528)	(1,873)	(2,134)	(2,134)	(1,373)	(1,679)
-1 m	3040	3040	2687	3040	2148	2148	1391	1760	1528	1528	928	1150	-	-	-	-	1027	1027	704	862
-(3' - 3'")	(6,702)	(6,702)	(5,925)	(6,702)	(4,737)	(4,737)	(3,066)	(3,880)	(3,369)	(3,369)	(2,047)	(2,536)	-	-	-	-	(2,265)	(2,265)	(1,553)	(1,901)
-2 m	2764	2764	2552	2764	1506	1506	1440	1506	1003	1003	969,3	1003	-	-	-	-	869	869	869	869
-(6' - 7'")	(6,094)	(6,094)	(5,627)	(6,094)	(3,320)	(3,320)	(3,175)	(3,320)	(2,212)	(2,212)	(2,137)	(2,212)	-	-	-	-	(1,915)	(1,915)	(1,915)	(1,915)

**32: Triple boom/single tires/stabilizer legs at rear/transport bar for clamshell bucket at front/long stick**

A \ B	2 m				3 m				4 m				5 m				max			
	(6' - 7'")				(9' - 10'")				(13' - 1'")				(16' - 5'")							
	I	II	III	IV	I	II	III	IV	I	II	III	IV	I	II	III	IV	I	II	III	IV
4 m	-	-	-	-	-	-	-	-	1125	1125	1125	1125	1079	1079	812.8	975.4	1083	1083	733	883
(13' - 1'")	-	-	-	-	-	-	-	-	(2,480)	(2,480)	(2,480)	(2,480)	(2,380)	(2,380)	(1,792)	(2,151)	(2,388)	(2,388)	(1,616)	(1,946)
3 m	-	-	-	-	1523	1523	1523	1523	1255	1255	1157	1255	1106	1106	795	957	1047	1047	620	752
(9' - 10'")	-	-	-	-	(3,358)	(3,358)	(3,358)	(3,358)	(2,767)	(2,767)	(2,552)	(2,767)	(2,439)	(2,439)	(1,753)	(2,109)	(2,310)	(2,310)	(1,368)	(1,658)
2 m	2823	2823	2823	2823	2078	2078	1635	2026	1466	1466	1069	1299	1186	1186	754	914	1031	998	564	688
(6' - 7'")	(6,225)	(6,225)	(6,225)	(6,225)	(4,582)	(4,582)	(3,605)	(4,468)	(3,232)	(3,232)	(2,357)	(2,865)	(2,616)	(2,616)	(1,663)	(2,016)	(2,272)	(2,201)	(1,245)	(1,518)
1 m	4770	4770	2762	3714	2496	2496	1451	1827	1650	1650	982	1207	1259	1259	711	869	1020	978	546	670
(3' - 3'")	(10,518)	(10,518)	(6,090)	(8,189)	(5,503)	(5,503)	(3,199)	(4,028)	(3,639)	(3,639)	(2,165)	(2,662)	(2,775)	(2,775)	(1,568)	(1,917)	(2,250)	(2,156)	(1,205)	(1,476)
0 m	4330	4330	2590	3514	2531	2531	1373	1742	1708	1698	926	1148	1265	1228	681	837	1006	1006	563	692
(0' - 0'")	(9,547)	(9,547)	(5,711)	(7,747)	(5,581)	(5,581)	(3,027)	(3,841)	(3,765)	(3,743)	(2,041)	(2,532)	(2,788)	(2,708)	(1,501)	(1,846)	(2,219)	(2,219)	(1,242)	(1,526)
-1 m	3538	3538	2619	3538	2275	2275	1363	1731	1587	1587	908	1130	1128	1128	674.2	830.8	971	971	627	771
(-3' - 3'")	(7,801)	(7,801)	(5,776)	(7,801)	(5,017)	(5,017)	(3,005)	(3,817)	(3,500)	(3,500)	(2,003)	(2,491)	(2,488)	(2,488)	(1,487)	(1,832)	(2,141)	(2,141)	(1,383)	(1,700)
-2 m	2509	2509	2509	2509	1737	1737	1399	1737	1207	1207	930.9	1154	-	-	-	-	869	869	787	869
(-6' - 7'")	(5,533)	(5,533)	(5,533)	(5,533)	(3,830)	(3,830)	(3,084)	(3,830)	(2,661)	(2,661)	(2,053)	(2,544)	-	-	-	-	(1,915)	(1,915)	(1,734)	(1,915)

**33: Triple boom/single tires/stabilizer legs at rear/parallel dozer blade at front/short stick**

A \ B	2 m				3 m				4 m				5 m				max			
	(6' - 7'")				(9' - 10'")				(13' - 1'")				(16' - 5'")							
	I	II	III	IV	I	II	III	IV	I	II	III	IV	I	II	III	IV	I	II	III	IV
4 m	-	-	-	-	-	-	-	-	1240	1240	1240	1240	-	-	-	-	1190	1190	892	1190
(13' - 1'")	-	-	-	-	-	-	-	-	(2,735)	(2,735)	(2,735)	(2,735)	-	-	-	-	(2,623)	(2,623)	(1,967)	(2,623)
3 m	-	-	-	-	1721	1721	1721	1721	1360	1360	1233	1360	1181	1181	859	1181	1141	1117	748	1066
(9' - 10'")	-	-	-	-	(3,794)	(3,794)	(3,794)	(3,794)	(2,999)	(2,999)	(2,719)	(2,999)	(2,603)	(2,603)	(1,893)	(2,603)	(2,516)	(2,463)	(1,649)	(2,350)
2 m	3234	3234	3234	3234	2260	2260	1722	2260	1554	1554	1149	1554	1242	1238	823	1176	1118	1025	681	981
(6' - 7'")	(7,130)	(7,130)	(7,130)	(7,130)	(4,984)	(4,984)	(3,797)	(4,984)	(3,426)	(3,426)	(2,533)	(3,426)	(2,740)	(2,730)	(1,816)	(2,593)	(2,465)	(2,261)	(1,501)	(2,162)
1 m	4961	4961	3003	4726	2571	2571	1566	2326	1703	1664	1071	1553	1291	1197	786	1137	1102	1004	661	960
(3' - 3'")	(10,940)	(10,940)	(6,622)	(10,420)	(5,668)	(5,668)	(3,454)	(5,128)	(3,756)	(3,669)	(2,362)	(3,425)	(2,847)	(2,640)	(1,734)	(2,507)	(2,431)	(2,213)	(1,458)	(2,116)
0 m	4088	4088	2902	4088	2488	2488	1518	2273	1712	1614	1027	1507	1259	1172	763	1113	968	968	686	968
(0' - 0'")	(9,015)	(9,015)	(6,399)	(9,015)	(5,486)	(5,486)	(3,346)	(5,012)	(3,775)	(3,559)	(2,265)	(3,322)	(2,775)	(2,584)	(1,683)	(2,454)	(2,134)	(2,134)	(1,513)	(2,134)
-1 m	3040	3040	2929	3040	2148	2148	1524	2148	1528	1528	1021	1500	-	-	-	-	1027	1027	775	1027
(-3' - 3'")	(6,702)	(6,702)	(6,460)	(6,702)	(4,737)	(4,737)	(3,361)	(4,737)	(3,369)	(3,369)	(2,250)	(3,307)	-	-	-	-	(2,265)	(2,265)	(1,709)	(2,265)
-2 m	2764	2764	2764	2764	1506	1506	1506	1506	1003	1003	1003	1003	-	-	-	-	869	869	869	869
(-6' - 7'")	(6,094)	(6,094)	(6,094)	(6,094)	(3,320)	(3,320)	(3,320)	(3,320)	(2,212)	(2,212)	(2,212)	(2,212)	-	-	-	-	(1,915)	(1,915)	(1,915)	(1,915)

**34: Triple boom/single tires/stabilizer legs at rear/parallel dozer blade at front/long stick**

A \ B	2 m				3 m				4 m				5 m				max			
	(6' - 7'")				(9' - 10'")				(13' - 1'")				(16' - 5'")							
	I	II	III	IV	I	II	III	IV	I	II	III	IV	I	II	III	IV	I	II	III	IV
4 m	-	-	-	-	-	-	-	-	1125	1125	1125	1125	1079	1079	883.1	1079	1083	1083	799	1083
(13' - 1'")	-	-	-	-	-	-	-	-	(2,480)	(2,480)	(2,480)	(2,480)	(2,380)	(2,380)	(1,947)	(2,380)	(2,388)	(2,388)	(1,762)	(2,388)
3 m	-	-	-	-	1523	1523	1523	1523	1255	1255	1249	1255	1106	1106	865	1106	1047	1021	681	976
(9' - 10'")	-	-	-	-	(3,358)	(3,358)	(3,358)	(3,358)	(2,767)	(2,767)	(2,755)	(2,767)	(2,439)	(2,439)	(1,908)	(2,439)	(2,310)	(2,251)	(1,501)	(2,153)
2 m	2823	2823	2823	2823	2078	2078	1768	2078	1466	1466	1161	1466	1186	1186	825	1178	1031	943	622	903
(6' - 7'")	(6,225)	(6,225)	(6,225)	(6,225)	(4,582)	(4,582)	(3,899)	(4,582)	(3,232)	(3,232)	(2,560)	(3,232)	(2,616)	(2,616)	(1,818)	(2,597)	(2,272)	(2,079)	(1,372)	(1,992)
1 m	4770	4770	3004	4730	2496	2496	1584	2347	1650	1650	1074	1557	1259	1193	781	1133	1020	923	604	884
(3' - 3'")	(10,518)	(10,518)	(6,625)	(10,429)	(5,503)	(5,503)	(3,493)	(5,175)	(3,639)	(3,639)	(2,368)	(3,433)	(2,775)	(2,632)	(1,723)	(2,497)	(2,250)	(2,035)	(1,332)	(1,950)
0 m	4330	4330	2833	4330	2531	2511	1506	2262	1708	1606	1018	1498	1265	1160	751	1101	1006	957	623	915
(0' - 0'")	(9,547)	(9,547)	(6,246)	(9,547)	(5,581)	(5,536)	(3,321)	(4,988)	(3,765)	(3,541)	(2,244)	(3,303)	(2,788)	(2,558)	(1,656)	(2,427)	(2,219)	(2,110)	(1,374)	(2,018)
-1 m	3538	3538	2862	3538	2275	2275	1496	2251	1587	1586	1000	1479	1128	1128	744.5	1094	971	971	693	971
(-3' - 3'")	(7,801)	(7,801)	(6,310)	(7,801)	(5,017)	(5,017)	(3,300)	(4,964)	(3,500)	(3,497)	(2,206)	(3,262)	(2,488)	(2,488)	(1,642)	(2,413)	(2,141)	(2,141)	(1,528)	(2,141)
-2 m	2509	2509	2509	2509	1737	1737	1532	1737	1207	1207	1023	1207	-	-	-	-	869	869	864	869
(-6' - 7'")	(5,533)	(5,533)	(5,533)	(5,533)	(3,830)	(3,830)	(3,378)	(3,830)	(2,661)	(2,661)	(2,256)	(2,661)	-	-	-	-	(1,915)	(1,915)	(1,906)	(1,915)

**35: Triple boom/single tires/stabilizer legs at front/parallel dozer blade at rear/short stick**

A B	2 m (6' - 7")				3 m (9' - 10")				4 m (13' - 1")				5 m (16' - 5")				max			
	I	II	III	IV	I	II	III	IV	I	II	III	IV	I	II	III	IV	I	II	III	IV
	4 m	-	-	-	-	-	-	-	-	1240	1240	1240	1240	-	-	-	-	1190	1190	892
(13' - 1")	-	-	-	-	-	-	-	-	(2,735)	(2,735)	(2,735)	(2,735)	-	-	-	-	(2,623)	(2,623)	(1,967)	(2,617)
3 m	-	-	-	-	1721	1721	1721	1721	1360	1360	1233	1360	1181	1181	859	1146	1141	1141	748	1006
(9' - 10")	-	-	-	-	(3,794)	(3,794)	(3,794)	(3,794)	(2,999)	(2,999)	(2,719)	(2,999)	(2,603)	(2,603)	(1,893)	(2,528)	(2,516)	(2,516)	(1,649)	(2,217)
2 m	3234	3234	3234	3234	2260	2260	1722	2260	1554	1554	1149	1548	1242	1242	823	1110	1118	1085	681	923
(6' - 7")	(7,130)	(7,130)	(7,130)	(7,130)	(4,984)	(4,984)	(3,797)	(4,984)	(3,426)	(3,426)	(2,533)	(3,412)	(2,740)	(2,740)	(1,816)	(2,447)	(2,465)	(2,393)	(1,501)	(2,036)
1 m	4961	4961	3003	4470	2571	2571	1566	2195	1703	1703	1071	1465	1291	1267	786	1071	1102	1063	661	903
(3' - 3")	10,940	10,940	(6,622)	(9,857)	(5,668)	(5,668)	(3,454)	(4,840)	(3,756)	(3,756)	(2,362)	(3,231)	(2,847)	(2,793)	(1,734)	(2,361)	(2,431)	(2,345)	(1,458)	(1,990)
0 m	4088	4088	2902	4088	2488	2488	1518	2142	1712	1708	1027	1419	1259	1242	763	1047	968	968	686	940
(0' - 0")	(9,015)	(9,015)	(6,399)	(9,015)	(5,486)	(5,486)	(3,346)	(4,723)	(3,775)	(3,766)	(2,265)	(3,128)	(2,775)	(2,738)	(1,683)	(2,308)	(2,134)	(2,134)	(1,513)	(2,072)
-1 m	3040	3040	2929	3040	2148	2148	1524	2148	1528	1528	1021	1412	-	-	-	-	1027	1027	775	1027
-(3' - 3")	(6,702)	(6,702)	(6,460)	(6,702)	(4,737)	(4,737)	(3,361)	(4,737)	(3,369)	(3,369)	(2,250)	(3,113)	-	-	-	-	(2,265)	(2,265)	(1,709)	(2,265)
-2 m	2764	2764	2764	2764	1506	1506	1506	1506	1003	1003	1003	1003	-	-	-	-	869	869	869	869
-(6' - 7")	(6,094)	(6,094)	(6,094)	(6,094)	(3,320)	(3,320)	(3,320)	(3,320)	(2,212)	(2,212)	(2,212)	(2,212)	-	-	-	-	(1,915)	(1,915)	(1,915)	(1,915)

**36: Triple boom/single tires/stabilizer legs at front/parallel dozer blade at rear/long stick**

A B	2 m (6' - 7")				3 m (9' - 10")				4 m (13' - 1")				5 m (16' - 5")				max			
	I	II	III	IV	I	II	III	IV	I	II	III	IV	I	II	III	IV	I	II	III	IV
	4 m	-	-	-	-	-	-	-	-	1125	1125	1125	1125	1079	1079	883.1	1079	1083	1083	799
(13' - 1")	-	-	-	-	-	-	-	-	(2,480)	(2,480)	(2,480)	(2,480)	(2,380)	(2,380)	(1,947)	(2,380)	(2,388)	(2,388)	(1,762)	(2,355)
3 m	-	-	-	-	1523	1523	1523	1523	1255	1255	1249	1255	1106	1106	865	1106	1047	1047	681	920
(9' - 10")	-	-	-	-	(3,358)	(3,358)	(3,358)	(3,358)	(2,767)	(2,767)	(2,755)	(2,767)	(2,439)	(2,439)	(1,908)	(2,439)	(2,310)	(2,310)	(1,501)	(2,028)
2 m	2823	2823	2823	2823	2078	2078	1768	2078	1466	1466	1161	1466	1186	1186	825	1112	1031	999	622	849
(6' - 7")	(6,225)	(6,225)	(6,225)	(6,225)	(4,582)	(4,582)	(3,899)	(4,582)	(3,232)	(3,232)	(2,560)	(3,232)	(2,616)	(2,616)	(1,818)	(2,451)	(2,272)	(2,204)	(1,372)	(1,873)
1 m	4770	4770	3004	4474	2496	2496	1584	2216	1650	1650	1074	1469	1259	1259	781	1066	1020	979	604	830
(3' - 3")	10,518	10,518	(6,625)	(9,866)	(5,503)	(5,503)	(3,493)	(4,886)	(3,639)	(3,639)	(2,368)	(3,240)	(2,775)	(2,775)	(1,723)	(2,352)	(2,250)	(2,159)	(1,332)	(1,831)
0 m	4330	4330	2833	4274	2531	2531	1506	2131	1708	1700	1018	1410	1265	1230	751	1035	1006	1006	623	859
(0' - 0")	(9,547)	(9,547)	(6,246)	(9,424)	(5,581)	(5,581)	(3,321)	(4,699)	(3,765)	(3,748)	(2,244)	(3,109)	(2,788)	(2,711)	(1,656)	(2,281)	(2,219)	(2,219)	(1,374)	(1,894)
-1 m	3538	3538	2862	3538	2275	2275	1496	2121	1587	1587	1000	1391	1128	1128	744.5	1028	971	971	693	954
-(3' - 3")	(7,801)	(7,801)	(6,310)	(7,801)	(5,017)	(5,017)	(3,300)	(4,676)	(3,500)	(3,500)	(2,206)	(3,068)	(2,488)	(2,488)	(1,642)	(2,267)	(2,141)	(2,141)	(1,528)	(2,104)
-2 m	2509	2509	2509	2509	1737	1737	1532	1737	1207	1207	1023	1207	-	-	-	-	869	869	864	869
-(6' - 7")	(5,533)	(5,533)	(5,533)	(5,533)	(3,830)	(3,830)	(3,378)	(3,830)	(2,661)	(2,661)	(2,256)	(2,661)	-	-	-	-	(1,915)	(1,915)	(1,906)	(1,915)

**37: Triple boom/single tires/transport bar for clamshell bucket at front/parallel dozer blade at rear/short stick**

A B	2 m (6' - 7")				3 m (9' - 10")				4 m (13' - 1")				5 m (16' - 5")				max			
	I	II	III	IV	I	II	III	IV	I	II	III	IV	I	II	III	IV	I	II	III	IV
	4 m	-	-	-	-	-	-	-	-	1240	1240	1210	1240	-	-	-	-	1190	1190	832
(13' - 1")	-	-	-	-	-	-	-	-	(2,735)	(2,735)	(2,669)	(2,735)	-	-	-	-	(2,623)	(2,623)	(1,835)	(2,139)
3 m	-	-	-	-	1721	1721	1721	1721	1360	1360	1157	1355	1181	1181	800	934	1141	1141	694	812
(9' - 10")	-	-	-	-	(3,794)	(3,794)	(3,794)	(3,794)	(2,999)	(2,999)	(2,550)	(2,987)	(2,603)	(2,603)	(1,764)	(2,059)	(2,516)	(2,516)	(1,531)	(1,791)
2 m	3234	3234	3234	3234	2260	2260	1611	1944	1554	1554	1072	1266	1242	1242	765	897	1118	1118	630	739
(6' - 7")	(7,130)	(7,130)	(7,130)	(7,130)	(4,984)	(4,984)	(3,552)	(4,287)	(3,426)	(3,426)	(2,364)	(2,790)	(2,740)	(2,740)	(1,687)	(1,978)	(2,465)	(2,465)	(1,388)	(1,630)
1 m	4961	4961	2802	3651	2571	2571	1455	1775	1703	1703	995	1183	1291	1291	728	858	1102	1102	610	719
(3' - 3")	10,940	10,940	(6,178)	(8,050)	(5,668)	(5,668)	(3,209)	(3,915)	(3,756)	(3,756)	(2,193)	(2,609)	(2,847)	(2,847)	(1,605)	(1,893)	(2,431)	(2,431)	(1,346)	(1,585)
0 m	4088	4088	2700	3533	2488	2488	1406	1722	1712	1712	950	1137	1259	1259	705	834	968	968	633	748
(0' - 0")	(9,015)	(9,015)	(5,954)	(7,790)	(5,486)	(5,486)	(3,101)	(3,798)	(3,775)	(3,775)	(2,096)	(2,506)	(2,775)	(2,775)	(1,554)	(1,840)	(2,134)	(2,134)	(1,396)	(1,649)
-1 m	3040	3040	2728	3040	2148	2148	1413	1730	1528	1528	944	1130	-	-	-	-	1027	1027	716	847
-(3' - 3")	(6,702)	(6,702)	(6,015)	(6,702)	(4,737)	(4,737)	(3,116)	(3,814)	(3,369)	(3,369)	(2,081)	(2,491)	-	-	-	-	(2,265)	(2,265)	(1,579)	(1,868)
-2 m	2764	2764	2593	2764	1506	1506	1462	1506	1003	1003	984.8	1003	-	-	-	-	869	869	869	869
-(6' - 7")	(6,094)	(6,094)	(5,717)	(6,094)	(3,320)	(3,320)	(3,224)	(3,320)	(2,212)	(2,212)	(2,172)	(2,212)	-	-	-	-	(1,915)	(1,915)	(1,915)	(1,915)

**38: Triple boom/single tires/transport bar for clamshell bucket at front/parallel dozer blade at rear/long stick**

A \ B	2 m				3 m				4 m				5 m				max			
	(6' - 7'")				(9' - 10'")				(13' - 1'")				(16' - 5'")							
	I	II	III	IV	I	II	III	IV	I	II	III	IV	I	II	III	IV	I	II	III	IV
4 m	-	-	-	-	-	-	-	-	1125	1125	1125	1125	1079	1079	824,6	960,2	1083	1083	744	868
(13' - 1'")	-	-	-	-	-	-	-	-	(2,480)	(2,480)	(2,480)	(2,480)	(2,380)	(2,380)	(1,818)	(2,117)	(2,388)	(2,388)	(1,641)	(1,915)
3 m	-	-	-	-	1523	1523	1523	1523	1255	1255	1173	1255	1106	1106	807	941	1047	1047	630	739
(9' - 10'")	-	-	-	-	(3,358)	(3,358)	(3,358)	(3,358)	(2,767)	(2,767)	(2,586)	(2,767)	(2,439)	(2,439)	(1,779)	(2,076)	(2,310)	(2,310)	(1,390)	(1,629)
2 m	2823	2823	2823	2823	2078	2078	1657	1996	1466	1466	1084	1279	1186	1186	766	899	1031	1031	574	676
(6' - 7'")	(6,225)	(6,225)	(6,225)	(6,225)	(4,582)	(4,582)	(3,655)	(4,402)	(3,232)	(3,232)	(2,391)	(2,820)	(2,616)	(2,616)	(1,689)	(1,983)	(2,272)	(2,272)	(1,266)	(1,491)
1 m	4770	4770	2803	3655	2496	2496	1473	1796	1650	1650	997	1187	1259	1259	723	854	1020	1019	556	657
(3' - 3'")	(10,518)	(10,518)	(6,180)	(8,060)	(5,503)	(5,503)	(3,249)	(3,961)	(3,639)	(3,639)	(2,199)	(2,618)	(2,775)	(2,775)	(1,594)	(1,883)	(2,250)	(2,247)	(1,226)	(1,449)
0 m	4330	4330	2631	3455	2531	2531	1395	1712	1708	1708	941	1128	1265	1265	692	822	1006	1006	573	679
(0' - 0'")	(9,547)	(9,547)	(5,801)	(7,618)	(5,581)	(5,581)	(3,076)	(3,774)	(3,765)	(3,765)	(2,075)	(2,487)	(2,788)	(2,788)	(1,527)	(1,813)	(2,219)	(2,219)	(1,264)	(1,497)
-1 m	3538	3538	2660	3489	2275	2275	1385	1701	1587	1587	924	1109	1128	1128	686	815,5	971	971	638	757
(-3' - 3'")	(7,801)	(7,801)	(5,866)	(7,693)	(5,017)	(5,017)	(3,055)	(3,751)	(3,500)	(3,500)	(2,037)	(2,446)	(2,488)	(2,488)	(1,513)	(1,798)	(2,141)	(2,141)	(1,408)	(1,669)
-2 m	2509	2509	2509	2509	1737	1737	1421	1737	1207	1207	946,4	1133	-	-	-	-	869	869	800	869
(-6' - 7'")	(5,533)	(5,533)	(5,533)	(5,533)	(3,830)	(3,830)	(3,133)	(3,830)	(2,661)	(2,661)	(2,087)	(2,499)	-	-	-	-	(1,915)	(1,915)	(1,763)	(1,915)

**39: Triple boom/single tires/parallel dozer blade at front/short stick**

A \ B	2 m				3 m				4 m				5 m				max			
	(6' - 7'")				(9' - 10'")				(13' - 1'")				(16' - 5'")							
	I	II	III	IV	I	II	III	IV	I	II	III	IV	I	II	III	IV	I	II	III	IV
4 m	-	-	-	-	-	-	-	-	1240	1240	1226	1240	-	-	-	-	1190	1139	844	1190
(13' - 1'")	-	-	-	-	-	-	-	-	(2,735)	(2,735)	(2,703)	(2,735)	-	-	-	-	(2,623)	(2,512)	(1,862)	(2,623)
3 m	-	-	-	-	1721	1721	1721	1721	1360	1360	1172	1360	1181	1098	812	1181	1141	955	705	1101
(9' - 10'")	-	-	-	-	(3,794)	(3,794)	(3,794)	(3,794)	(2,999)	(2,999)	(2,584)	(2,999)	(2,603)	(2,420)	(1,790)	(2,603)	(2,516)	(2,105)	(1,555)	(2,427)
2 m	3234	3234	3234	3234	2260	2260	1633	2260	1554	1510	1088	1554	1242	1059	777	1214	1118	871	640	1014
(6' - 7'")	(7,130)	(7,130)	(7,130)	(7,130)	(4,984)	(4,984)	(3,601)	(4,984)	(3,426)	(3,329)	(2,398)	(3,426)	(2,740)	(2,335)	(1,713)	(2,677)	(2,465)	(1,921)	(1,411)	(2,235)
1 m	4961	4961	2842	4873	2571	2207	1478	2402	1703	1422	1010	1604	1291	1018	740	1175	1102	850	620	993
(3' - 3'")	(10,940)	(10,940)	(6,267)	(10,746)	(5,668)	(4,866)	(3,258)	(5,295)	(3,756)	(3,135)	(2,227)	(3,537)	(2,847)	(2,245)	(1,631)	(2,591)	(2,431)	(1,874)	(1,368)	(2,189)
0 m	4088	4088	2741	4088	2488	2148	1429	2349	1712	1372	966	1557	1259	993	717	1151	968	886	644	968
(0' - 0'")	(9,015)	(9,015)	(6,044)	(9,015)	(5,486)	(4,736)	(3,151)	(5,178)	(3,775)	(3,025)	(2,130)	(3,434)	(2,775)	(2,189)	(1,580)	(2,539)	(2,134)	(1,954)	(1,420)	(2,134)
-1 m	3040	3040	2768	3040	2148	2148	1435	2148	1528	1364	959	1528	-	-	-	-	1027	1007	728	1027
(-3' - 3'")	(6,702)	(6,702)	(6,104)	(6,702)	(4,737)	(4,737)	(3,165)	(4,737)	(3,369)	(3,009)	(2,115)	(3,369)	-	-	-	-	(2,265)	(2,220)	(1,605)	(2,265)
-2 m	2764	2764	2633	2764	1506	1506	1485	1506	1003	1003	1000	1003	-	-	-	-	869	869	869	869
(-6' - 7'")	(6,094)	(6,094)	(5,807)	(6,094)	(3,320)	(3,320)	(3,273)	(3,320)	(2,212)	(2,212)	(2,206)	(2,212)	-	-	-	-	(1,915)	(1,915)	(1,915)	(1,915)

**40: Triple boom/single tires/parallel dozer blade at front/long stick**

A \ B	2 m				3 m				4 m				5 m				max			
	(6' - 7'")				(9' - 10'")				(13' - 1'")				(16' - 5'")							
	I	II	III	IV	I	II	III	IV	I	II	III	IV	I	II	III	IV	I	II	III	IV
4 m	-	-	-	-	-	-	-	-	1125	1125	1125	1125	1079	1079	836,4	1079	1083	1019	755	1083
(13' - 1'")	-	-	-	-	-	-	-	-	(2,480)	(2,480)	(2,480)	(2,480)	(2,380)	(2,380)	(1,844)	(2,380)	(2,388)	(2,248)	(1,665)	(2,388)
3 m	-	-	-	-	1523	1523	1523	1523	1255	1255	1188	1255	1106	1106	818	1106	1047	869	640	1009
(9' - 10'")	-	-	-	-	(3,358)	(3,358)	(3,358)	(3,358)	(2,767)	(2,767)	(2,620)	(2,767)	(2,439)	(2,439)	(1,805)	(2,439)	(2,310)	(1,917)	(1,412)	(2,225)
2 m	2823	2823	2823	2823	2078	2078	1680	2078	1466	1466	1100	1466	1186	1062	778	1186	1031	798	584	935
(6' - 7'")	(6,225)	(6,225)	(6,225)	(6,225)	(4,582)	(4,582)	(3,704)	(4,582)	(3,232)	(3,232)	(2,425)	(3,232)	(2,616)	(2,341)	(1,715)	(2,616)	(2,272)	(1,760)	(1,288)	(2,061)
1 m	4770	4770	2843	4770	2496	2232	1496	2423	1650	1427	1013	1608	1259	1014	735	1171	1020	778	566	915
(3' - 3'")	(10,518)	(10,518)	(6,270)	(10,518)	(5,503)	(4,921)	(3,298)	(5,342)	(3,639)	(3,147)	(2,233)	(3,546)	(2,775)	(2,237)	(1,620)	(2,582)	(2,250)	(1,716)	(1,248)	(2,018)
0 m	4330	4330	2672	4330	2531	2138	1418	2338	1708	1364	957	1549	1265	981	704	1139	1006	806	583	948
(0' - 0'")	(9,547)	(9,547)	(5,891)	(9,547)	(5,581)	(4,714)	(3,126)	(5,155)	(3,765)	(3,007)	(2,110)	(3,415)	(2,788)	(2,163)	(1,553)	(2,512)	(2,219)	(1,778)	(1,287)	(2,090)
-1 m	3538	3538	2701	3538	2275	2126	1408	2275	1587	1344	939	1530	1128	973,8	697,8	1128	971	900	649	971
(-3' - 3'")	(7,801)	(7,801)	(5,955)	(7,801)	(5,017)	(4,688)	(3,104)	(5,017)	(3,500)	(2,963)	(2,071)	(3,374)	(2,488)	(2,147)	(1,539)	(2,488)	(2,141)	(1,986)	(1,432)	(2,141)
-2 m	2509	2509	2509	2509	1737	1737	1443	1737	1207	1207	961,8	1207	-	-	-	-	869	869	813	869
(-6' - 7'")	(5,533)	(5,533)	(5,533)	(5,533)	(3,830)	(3,830)	(3,183)	(3,830)	(2,661)	(2,661)	(2,121)	(2,661)	-	-	-	-	(1,915)	(1,915)	(1,792)	(1,915)

**41: Triple boom/single tires/dozer blade at front/short stick**

A B	2 m (6' - 7")				3 m (9' - 10")				4 m (13' - 1")				5 m (16' - 5")				max			
	I	II	III	IV	I	II	III	IV	I	II	III	IV	I	II	III	IV	I	II	III	IV
4 m	-	-	-	-	-	-	-	-	1240	1240	1202	1240	-	-	-	-	1190	1158	826	1190
(13' - 1")	-	-	-	-	-	-	-	-	(2,735)	(2,735)	(2,650)	(2,735)	-	-	-	-	(2,623)	(2,554)	(1,821)	(2,623)
3 m	-	-	-	-	1721	1721	1721	1721	1360	1360	1148	1360	1181	1116	794	1181	1141	971	688	1037
(9' - 10")	-	-	-	-	(3,794)	(3,794)	(3,794)	(3,794)	(2,999)	(2,999)	(2,531)	(2,999)	(2,603)	(2,461)	(1,750)	(2,603)	(2,516)	(2,142)	(1,518)	(2,287)
2 m	3234	3234	3234	3234	2260	2260	1599	2260	1554	1535	1064	1554	1242	1077	758	1145	1118	887	624	954
(6' - 7")	(7,130)	(7,130)	(7,130)	(7,130)	(4,984)	(4,984)	(3,525)	(4,984)	(3,426)	(3,384)	(2,346)	(3,426)	(2,740)	(2,376)	(1,672)	(2,524)	(2,465)	(1,956)	(1,376)	(2,103)
1 m	4961	4961	2779	4605	2571	2245	1443	2264	1703	1447	986	1512	1291	1037	721	1106	1102	866	605	933
(3' - 3")	(10,940)	(10,940)	(6,128)	(10,155)	(5,668)	(4,951)	(3,182)	(4,993)	(3,756)	(3,190)	(2,174)	(3,334)	(2,847)	(2,286)	(1,590)	(2,438)	(2,431)	(1,909)	(1,333)	(2,057)
0 m	4088	4088	2678	4088	2488	2187	1394	2211	1712	1397	942	1465	1259	1011	698	1082	968	903	627	968
(0' - 0")	(9,015)	(9,015)	(5,905)	(9,015)	(5,486)	(4,822)	(3,074)	(4,876)	(3,775)	(3,080)	(2,077)	(3,231)	(2,775)	(2,230)	(1,540)	(2,385)	(2,134)	(1,991)	(1,383)	(2,134)
-1 m	3040	3040	2705	3040	2148	2148	1401	2148	1528	1390	935	1458	-	-	-	-	1027	1026	710	1027
-(3' - 3")	(6,702)	(6,702)	(5,965)	(6,702)	(4,737)	(4,737)	(3,088)	(4,737)	(3,369)	(3,064)	(2,062)	(3,216)	-	-	-	-	(2,265)	(2,261)	(1,565)	(2,265)
-2 m	2764	2764	2570	2764	1506	1506	1450	1506	1003	1003	976,3	1003	-	-	-	-	869	869	869	869
-(6' - 7")	(6,094)	(6,094)	(5,667)	(6,094)	(3,320)	(3,320)	(3,197)	(3,320)	(2,212)	(2,212)	(2,153)	(2,212)	-	-	-	-	(1,915)	(1,915)	(1,915)	(1,915)

**42: Triple boom/single tires/dozer blade at front/long stick**

A B	2 m (6' - 7")				3 m (9' - 10")				4 m (13' - 1")				5 m (16' - 5")				max			
	I	II	III	IV	I	II	III	IV	I	II	III	IV	I	II	III	IV	I	II	III	IV
4 m	-	-	-	-	-	-	-	-	1125	1125	1125	1125	1079	1079	818,1	1079	1083	1037	738	1083
(13' - 1")	-	-	-	-	-	-	-	-	(2,480)	(2,480)	(2,480)	(2,480)	(2,380)	(2,380)	(1,804)	(2,380)	(2,388)	(2,286)	(1,627)	(2,388)
3 m	-	-	-	-	1523	1523	1523	1523	1255	1255	1164	1255	1106	1106	800	1106	1047	885	625	950
(9' - 10")	-	-	-	-	(3,358)	(3,358)	(3,358)	(3,358)	(2,767)	(2,767)	(2,567)	(2,767)	(2,439)	(2,439)	(1,764)	(2,439)	(2,310)	(1,952)	(1,378)	(2,094)
2 m	2823	2823	2823	2823	2078	2078	1645	2078	1466	1466	1076	1466	1186	1080	760	1147	1031	813	569	878
(6' - 7")	(6,225)	(6,225)	(6,225)	(6,225)	(4,582)	(4,582)	(3,627)	(4,582)	(3,232)	(3,232)	(2,372)	(3,232)	(2,616)	(2,382)	(1,675)	(2,528)	(2,272)	(1,793)	(1,254)	(1,936)
1 m	4770	4770	2780	4610	2496	2271	1461	2285	1650	1452	989	1516	1259	1033	716	1101	1020	793	551	859
(3' - 3")	(10,518)	(10,518)	(6,130)	(10,164)	(5,503)	(5,007)	(3,221)	(5,039)	(3,639)	(3,202)	(2,180)	(3,342)	(2,775)	(2,278)	(1,580)	(2,429)	(2,250)	(1,749)	(1,214)	(1,894)
0 m	4330	4330	2608	4330	2531	2177	1383	2200	1708	1389	933	1456	1265	999	686	1070	1006	822	568	889
(0' - 0")	(9,547)	(9,547)	(5,751)	(9,547)	(5,581)	(4,799)	(3,049)	(4,852)	(3,765)	(3,062)	(2,057)	(3,212)	(2,788)	(2,204)	(1,512)	(2,358)	(2,219)	(1,812)	(1,252)	(1,960)
-1 m	3538	3538	2638	3538	2275	2165	1373	2190	1587	1369	915	1438	1128	992,4	679,4	1063	971	918	632	971
-(3' - 3")	(7,801)	(7,801)	(5,816)	(7,801)	(5,017)	(4,774)	(3,027)	(4,829)	(3,500)	(3,018)	(2,018)	(3,171)	(2,488)	(2,188)	(1,498)	(2,344)	(2,141)	(2,023)	(1,394)	(2,141)
-2 m	2509	2509	2509	2509	1737	1737	1409	1737	1207	1207	937,8	1207	-	-	-	-	869	869	792	869
-(6' - 7")	(5,533)	(5,533)	(5,533)	(5,533)	(3,830)	(3,830)	(3,106)	(3,830)	(2,661)	(2,661)	(2,068)	(2,661)	-	-	-	-	(1,915)	(1,915)	(1,747)	(1,915)

**43: Triple articulation boom/twin tires/stabilizer blade at rear/transport bar for clamshell bucket at front/ short stick**

A \ B	2 m				3 m				4 m				5 m				max			
	(6' - 7'")				(9' - 10'")				(13' - 1'")				(16' - 5'")							
	I	II	III	IV	I	II	III	IV	I	II	III	IV	I	II	III	IV	I	II	III	IV
4 m	-	-	-	-	-	-	-	-	1240	1240	1240	1240	-	-	-	-	1190	1190	906	1033
(13' - 1'")	-	-	-	-	-	-	-	-	(2,735)	(2,735)	(2,735)	(2,735)	-	-	-	-	(2,623)	(2,623)	(1,997)	(2,278)
3 m	-	-	-	-	1721	1721	1721	1721	1360	1360	1255	1360	1181	1181	872	995	1141	1141	759	868
(9' - 10'")	-	-	-	-	(3,794)	(3,794)	(3,794)	(3,794)	(2,999)	(2,999)	(2,768)	(2,999)	(2,603)	(2,603)	(1,923)	(2,195)	(2,516)	(2,516)	(1,673)	(1,914)
2 m	3234	3234	3234	3234	2260	2260	1763	2066	1554	1554	1170	1347	1242	1242	836	959	1118	1105	690	792
(6' - 7'")	(7,130)	(7,130)	(7,130)	(7,130)	(4,984)	(4,984)	(3,888)	(4,555)	(3,426)	(3,426)	(2,580)	(2,971)	(2,740)	(2,740)	(1,844)	(2,114)	(2,465)	(2,436)	(1,523)	(1,747)
1 m	4961	4961	3124	3888	2571	2571	1605	1897	1703	1703	1091	1265	1291	1289	799	920	1102	1083	671	772
(3' - 3'")	(10,940)	(10,940)	(6,889)	(8,574)	(5,668)	(5,668)	(3,539)	(4,183)	(3,756)	(3,756)	(2,406)	(2,789)	(2,847)	(2,843)	(1,761)	(2,028)	(2,431)	(2,387)	(1,479)	(1,702)
0 m	4088	4088	3019	3770	2488	2488	1555	1844	1712	1712	1047	1218	1259	1259	776	896	968	968	697	803
(0' - 0'")	(9,015)	(9,015)	(6,658)	(8,313)	(5,486)	(5,486)	(3,429)	(4,066)	(3,775)	(3,775)	(2,308)	(2,686)	(2,775)	(2,775)	(1,710)	(1,976)	(2,134)	(2,134)	(1,536)	(1,771)
-1 m	3040	3040	3040	3040	2148	2148	1562	1851	1528	1528	1040	1211	-	-	-	-	1027	1027	787	909
(-3' - 3'")	(6,702)	(6,702)	(6,702)	(6,702)	(4,737)	(4,737)	(3,444)	(4,082)	(3,369)	(3,369)	(2,293)	(2,671)	-	-	-	-	(2,265)	(2,265)	(1,736)	(2,004)
-2 m	2764	2764	2764	2764	1506	1506	1506	1506	1003	1003	1003	1003	-	-	-	-	869	869	869	869
(-6' - 7'")	(6,094)	(6,094)	(6,094)	(6,094)	(3,320)	(3,320)	(3,320)	(3,320)	(2,212)	(2,212)	(2,212)	(2,212)	-	-	-	-	(1,915)	(1,915)	(1,915)	(1,915)

**44: Triple articulation boom/twin tires/stabilizer blade at rear/transport bar for clamshell bucket at front/ long stick**

A \ B	2 m				3 m				4 m				5 m				max			
	(6' - 7'")				(9' - 10'")				(13' - 1'")				(16' - 5'")							
	I	II	III	IV	I	II	III	IV	I	II	III	IV	I	II	III	IV	I	II	III	IV
4 m	-	-	-	-	-	-	-	-	1125	1125	1125	1125	1079	1079	896.7	1022	1083	1083	811	926
(13' - 1'")	-	-	-	-	-	-	-	-	(2,480)	(2,480)	(2,480)	(2,480)	(2,380)	(2,380)	(1,977)	(2,253)	(2,388)	(2,388)	(1,789)	(2,042)
3 m	-	-	-	-	1523	1523	1523	1523	1255	1255	1255	1255	1106	1106	879	1003	1047	1047	690	791
(9' - 10'")	-	-	-	-	(3,358)	(3,358)	(3,358)	(3,358)	(2,767)	(2,767)	(2,767)	(2,767)	(2,439)	(2,439)	(1,937)	(2,211)	(2,310)	(2,310)	(1,522)	(1,745)
2 m	2823	2823	2823	2823	2078	2078	1811	2078	1466	1466	1182	1361	1186	1186	838	961	1031	1018	631	726
(6' - 7'")	(6,225)	(6,225)	(6,225)	(6,225)	(4,582)	(4,582)	(3,994)	(4,582)	(3,232)	(3,232)	(2,607)	(3,001)	(2,616)	(2,616)	(1,847)	(2,118)	(2,272)	(2,244)	(1,392)	(1,601)
1 m	4770	4770	3126	3892	2496	2496	1624	1918	1650	1650	1094	1269	1259	1259	794	916	1020	997	613	707
(3' - 3'")	(10,518)	(10,518)	(6,893)	(8,583)	(5,503)	(5,503)	(3,580)	(4,229)	(3,639)	(3,639)	(2,413)	(2,798)	(2,775)	(2,775)	(1,751)	(2,019)	(2,250)	(2,199)	(1,352)	(1,560)
0 m	4330	4330	2948	3692	2531	2531	1544	1833	1708	1708	1037	1210	1265	1252	763	884	1006	1006	633	731
(0' - 0'")	(9,547)	(9,547)	(6,501)	(8,141)	(5,581)	(5,581)	(3,404)	(4,042)	(3,765)	(3,765)	(2,288)	(2,667)	(2,788)	(2,761)	(1,683)	(1,948)	(2,219)	(2,219)	(1,395)	(1,612)
-1 m	3538	3538	2978	3538	2275	2275	1534	1823	1587	1587	1020	1191	1128	1128	756.7	877	971	971	704	814
(-3' - 3'")	(7,801)	(7,801)	(6,567)	(7,801)	(5,017)	(5,017)	(3,383)	(4,019)	(3,500)	(3,500)	(2,248)	(2,626)	(2,488)	(2,488)	(1,669)	(1,934)	(2,141)	(2,141)	(1,552)	(1,795)
-2 m	2509	2509	2509	2509	1737	1737	1570	1737	1207	1207	1043	1207	-	-	-	-	869	869	869	869
(-6' - 7'")	(5,533)	(5,533)	(5,533)	(5,533)	(3,830)	(3,830)	(3,462)	(3,830)	(2,661)	(2,661)	(2,299)	(2,661)	-	-	-	-	(1,915)	(1,915)	(1,915)	(1,915)

**45: Triple articulation boom/twin tires/stabilizer legs at rear/transport bar for clamshell bucket at front/ short stick**

A \ B	2 m				3 m				4 m				5 m				max			
	(6' - 7'")				(9' - 10'")				(13' - 1'")				(16' - 5'")							
	I	II	III	IV	I	II	III	IV	I	II	III	IV	I	II	III	IV	I	II	III	IV
4 m	-	-	-	-	-	-	-	-	1240	1240	1240	1240	-	-	-	-	1190	1190	913	1031
(13' - 1'")	-	-	-	-	-	-	-	-	(2,735)	(2,735)	(2,735)	(2,735)	-	-	-	-	(2,623)	(2,623)	(2,014)	(2,273)
3 m	-	-	-	-	1721	1721	1721	1721	1360	1360	1265	1360	1181	1181	879	994	1141	1141	766	866
(9' - 10'")	-	-	-	-	(3,794)	(3,794)	(3,794)	(3,794)	(2,999)	(2,999)	(2,789)	(2,999)	(2,603)	(2,603)	(1,939)	(2,191)	(2,516)	(2,516)	(1,688)	(1,910)
2 m	3234	3234	3234	3234	2260	2260	1777	2062	1554	1554	1180	1345	1242	1242	844	957	1118	1118	697	791
(6' - 7'")	(7,130)	(7,130)	(7,130)	(7,130)	(4,984)	(4,984)	(3,919)	(4,547)	(3,426)	(3,426)	(2,601)	(2,965)	(2,740)	(2,740)	(1,860)	(2,110)	(2,465)	(2,465)	(1,537)	(1,744)
1 m	4961	4961	3150	3881	2571	2571	1619	1893	1703	1703	1101	1262	1291	1291	806	918	1102	1102	677	770
(3' - 3'")	(10,940)	(10,940)	(6,946)	(8,557)	(5,668)	(5,668)	(3,570)	(4,174)	(3,756)	(3,756)	(2,427)	(2,784)	(2,847)	(2,847)	(1,777)	(2,024)	(2,431)	(2,430)	(1,493)	(1,699)
0 m	4088	4088	3045	3763	2488	2488	1569	1840	1712	1712	1056	1216	1259	1259	783	894	968	968	703	802
(0' - 0'")	(9,015)	(9,015)	(6,715)	(8,297)	(5,486)	(5,486)	(3,460)	(4,058)	(3,775)	(3,775)	(2,329)	(2,681)	(2,775)	(2,775)	(1,726)	(1,971)	(2,134)	(2,134)	(1,551)	(1,768)
-1 m	3040	3040	3040	3040	2148	2148	1576	1847	1528	1528	1050	1209	-	-	-	-	1027	1027	795	907
(-3' - 3'")	(6,702)	(6,702)	(6,702)	(6,702)	(4,737)	(4,737)	(3,475)	(4,073)	(3,369)	(3,369)	(2,314)	(2,666)	-	-	-	-	(2,265)	(2,265)	(1,752)	(2,000)
-2 m	2764	2764	2764	2764	1506	1506	1506	1506	1003	1003	1003	1003	-	-	-	-	869	869	869	869
(-6' - 7'")	(6,094)	(6,094)	(6,094)	(6,094)	(3,320)	(3,320)	(3,320)	(3,320)	(2,212)	(2,212)	(2,212)	(2,212)	-	-	-	-	(1,915)	(1,915)	(1,915)	(1,915)

**46: Triple articulation boom/twin tires/stabilizer legs at rear/transport bar for clamshell bucket at front/long stick**

A B	2 m				3 m				4 m				5 m				max			
	(6' - 7'')				(9' - 10'')				(13' - 1'')				(16' - 5'')							
	I	II	III	IV	I	II	III	IV	I	II	III	IV	I	II	III	IV	I	II	III	IV
4 m	-	-	-	-	-	-	-	-	1125	1125	1125	1125	1079	1079	904	1020	1083	1083	818	924
(13' - 1'')	-	-	-	-	-	-	-	-	(2,480)	(2,480)	(2,480)	(2,480)	(2,380)	(2,380)	(1,993)	(2,249)	(2,388)	(2,388)	(1,804)	(2,038)
3 m	-	-	-	-	1523	1523	1523	1523	1255	1255	1255	1255	1106	1106	886	1001	1047	1047	697	790
(9' - 10'')	-	-	-	-	(3,358)	(3,358)	(3,358)	(3,358)	(2,767)	(2,767)	(2,767)	(2,767)	(2,439)	(2,439)	(1,953)	(2,207)	(2,310)	(2,310)	(1,536)	(1,741)
2 m	2823	2823	2823	2823	2078	2078	1825	2078	1466	1466	1192	1358	1186	1186	845	959	1031	1031	637	725
(6' - 7'')	(6,225)	(6,225)	(6,225)	(6,225)	(4,582)	(4,582)	(4,024)	(4,582)	(3,232)	(3,232)	(2,628)	(2,995)	(2,616)	(2,616)	(1,863)	(2,114)	(2,272)	(2,272)	(1,405)	(1,598)
1 m	4770	4770	3152	3885	2496	2496	1638	1914	1650	1650	1104	1266	1259	1259	801	914	1020	1015	619	706
(3' - 3'')	10,518	10,518	(6,950)	(8,566)	(5,503)	(5,503)	(3,611)	(4,221)	(3,639)	(3,639)	(2,434)	(2,792)	(2,775)	(2,775)	(1,767)	(2,015)	(2,250)	(2,239)	(1,365)	(1,556)
0 m	4330	4330	2974	3685	2531	2531	1558	1829	1708	1708	1047	1207	1265	1265	770	882	1006	1006	639	730
(0' - 0'')	(9,547)	(9,547)	(6,558)	(8,124)	(5,581)	(5,581)	(3,435)	(4,034)	(3,765)	(3,765)	(2,309)	(2,662)	(2,788)	(2,788)	(1,699)	(1,944)	(2,219)	(2,219)	(1,409)	(1,609)
-1 m	3538	3538	3004	3538	2275	2275	1548	1819	1587	1587	1029	1188	1128	1128	764	875,1	971	971	711	812
-(3' - 3'')	(7,801)	(7,801)	(6,624)	(7,801)	(5,017)	(5,017)	(3,413)	(4,010)	(3,500)	(3,500)	(2,270)	(2,621)	(2,488)	(2,488)	(1,685)	(1,930)	(2,141)	(2,141)	(1,567)	(1,791)
-2 m	2509	2509	2509	2509	1737	1737	1584	1737	1207	1207	1052	1207	-	-	-	-	869	869	869	869
-(6' - 7'')	(5,533)	(5,533)	(5,533)	(5,533)	(3,830)	(3,830)	(3,493)	(3,830)	(2,661)	(2,661)	(2,320)	(2,661)	-	-	-	-	(1,915)	(1,915)	(1,915)	(1,915)

**47: Triple articulation boom/twin tires/stabilizer legs at rear/parallel stabilizer blade at front/short stick**

A B	2 m				3 m				4 m				5 m				max			
	(6' - 7'')				(9' - 10'')				(13' - 1'')				(16' - 5'')							
	I	II	III	IV	I	II	III	IV	I	II	III	IV	I	II	III	IV	I	II	III	IV
4 m	-	-	-	-	-	-	-	-	1240	1240	1240	1240	-	-	-	-	1190	1190	989	1190
(13' - 1'')	-	-	-	-	-	-	-	-	(2,735)	(2,735)	(2,735)	(2,735)	-	-	-	-	(2,623)	(2,623)	(2,182)	(2,623)
3 m	-	-	-	-	1721	1721	1721	1721	1360	1360	1360	1360	1181	1181	954	1181	1141	1141	834	1106
(9' - 10'')	-	-	-	-	(3,794)	(3,794)	(3,794)	(3,794)	(2,999)	(2,999)	(2,999)	(2,999)	(2,603)	(2,603)	(2,103)	(2,603)	(2,516)	(2,516)	(1,839)	(2,439)
2 m	3234	3234	3234	3234	2260	2260	1921	2260	1554	1554	1278	1554	1242	1242	918	1220	1118	1066	762	1019
(6' - 7'')	(7,130)	(7,130)	(7,130)	(7,130)	(4,984)	(4,984)	(4,235)	(4,984)	(3,426)	(3,426)	(2,818)	(3,426)	(2,740)	(2,740)	(2,025)	(2,690)	(2,465)	(2,350)	(1,680)	(2,247)
1 m	4961	4961	3414	4897	2571	2571	1762	2413	1703	1703	1199	1612	1291	1244	881	1181	1102	1044	742	998
(3' - 3'')	10,940	10,940	(7,528)	(10,797)	(5,668)	(5,668)	(3,885)	(5,322)	(3,756)	(3,756)	(2,644)	(3,555)	(2,847)	(2,742)	(1,942)	(2,605)	(2,431)	(2,301)	(1,636)	(2,201)
0 m	4088	4088	3309	4088	2488	2488	1712	2360	1712	1677	1154	1565	1259	1219	858	1157	968	968	771	968
(0' - 0'')	(9,015)	(9,015)	(7,297)	(9,015)	(5,486)	(5,486)	(3,776)	(5,205)	(3,775)	(3,697)	(2,545)	(3,452)	(2,775)	(2,687)	(1,891)	(2,552)	(2,134)	(2,134)	(1,701)	(2,134)
-1 m	3040	3040	3040	3040	2148	2148	1719	2148	1528	1528	1148	1528	-	-	-	-	1027	1027	870	1027
-(3' - 3'')	(6,702)	(6,702)	(6,702)	(6,702)	(4,737)	(4,737)	(3,790)	(4,737)	(3,369)	(3,369)	(2,531)	(3,369)	-	-	-	-	(2,265)	(2,265)	(1,918)	(2,265)
-2 m	2764	2764	2764	2764	1506	1506	1506	1506	1003	1003	1003	1003	-	-	-	-	869	869	869	869
-(6' - 7'')	(6,094)	(6,094)	(6,094)	(6,094)	(3,320)	(3,320)	(3,320)	(3,320)	(2,212)	(2,212)	(2,212)	(2,212)	-	-	-	-	(1,915)	(1,915)	(1,915)	(1,915)

**48: Triple articulation boom/twin tires/stabilizer legs at rear/parallel stabilizer blade at front/long stick**

A B	2 m				3 m				4 m				5 m				max			
	(6' - 7'')				(9' - 10'')				(13' - 1'')				(16' - 5'')							
	I	II	III	IV	I	II	III	IV	I	II	III	IV	I	II	III	IV	I	II	III	IV
4 m	-	-	-	-	-	-	-	-	1125	1125	1125	1125	1079	1079	978,8	1079	1083	1083	889	1083
(13' - 1'')	-	-	-	-	-	-	-	-	(2,480)	(2,480)	(2,480)	(2,480)	(2,380)	(2,380)	(2,158)	(2,380)	(2,388)	(2,388)	(1,959)	(2,388)
3 m	-	-	-	-	1523	1523	1523	1523	1255	1255	1255	1255	1106	1106	961	1106	1047	1047	761	1014
(9' - 10'')	-	-	-	-	(3,358)	(3,358)	(3,358)	(3,358)	(2,767)	(2,767)	(2,767)	(2,767)	(2,439)	(2,439)	(2,118)	(2,439)	(2,310)	(2,310)	(1,678)	(2,236)
2 m	2823	2823	2823	2823	2078	2078	1968	2078	1466	1466	1290	1466	1186	1186	920	1186	1031	981	699	940
(6' - 7'')	(6,225)	(6,225)	(6,225)	(6,225)	(4,582)	(4,582)	(4,340)	(4,582)	(3,232)	(3,232)	(2,845)	(3,232)	(2,616)	(2,616)	(2,028)	(2,616)	(2,272)	(2,163)	(1,541)	(2,072)
1 m	4770	4770	3416	4770	2496	2496	1781	2434	1650	1650	1202	1616	1259	1240	876	1177	1020	960	680	920
(3' - 3'')	10,518	10,518	(7,532)	10,518	(5,503)	(5,503)	(3,927)	(5,368)	(3,639)	(3,639)	(2,650)	(3,563)	(2,775)	(2,734)	(1,932)	(2,595)	(2,250)	(2,118)	(1,500)	(2,029)
0 m	4330	4330	3238	4330	2531	2531	1701	2350	1708	1669	1145	1557	1265	1207	845	1145	1006	996	703	953
(0' - 0'')	(9,547)	(9,547)	(7,140)	(9,547)	(5,581)	(5,581)	(3,751)	(5,181)	(3,765)	(3,679)	(2,525)	(3,433)	(2,788)	(2,660)	(1,864)	(2,525)	(2,219)	(2,196)	(1,549)	(2,101)
-1 m	3538	3538	3268	3538	2275	2275	1691	2275	1587	1587	1127	1538	1128	1128	838,8	1128	971	971	780	971
-(3' - 3'')	(7,801)	(7,801)	(7,207)	(7,801)	(5,017)	(5,017)	(3,729)	(5,017)	(3,500)	(3,500)	(2,486)	(3,392)	(2,488)	(2,488)	(1,849)	(2,488)	(2,141)	(2,141)	(1,720)	(2,141)
-2 m	2509	2509	2509	2509	1737	1737	1727	1737	1207	1207	1150	1207	-	-	-	-	869	869	869	869
-(6' - 7'')	(5,533)	(5,533)	(5,533)	(5,533)	(3,830)	(3,830)	(3,809)	(3,830)	(2,661)	(2,661)	(2,537)	(2,661)	-	-	-	-	(1,915)	(1,915)	(1,915)	(1,915)

**49: Triple articulation boom/twin tires/stabilizer legs at front/parallel stabilizer blade at rear/short stick**

A \ B	2 m				3 m				4 m				5 m				max			
	(6' - 7'")				(9' - 10'")				(13' - 1'")				(16' - 5'")							
	I	II	III	IV	I	II	III	IV	I	II	III	IV	I	II	III	IV	I	II	III	IV
4 m	-	-	-	-	-	-	-	-	1240	1240	1240	1240	-	-	-	-	1190	1190	989	1190
(13' - 1'")	-	-	-	-	-	-	-	-	(2,735)	(2,735)	(2,735)	(2,735)	-	-	-	-	(2,623)	(2,623)	(2,182)	(2,623)
3 m	-	-	-	-	1721	1721	1721	1721	1360	1360	1360	1360	1181	1181	954	1181	1141	1141	834	1046
(9' - 10'")	-	-	-	-	(3,794)	(3,794)	(3,794)	(3,794)	(2,999)	(2,999)	(2,999)	(2,999)	(2,603)	(2,603)	(2,103)	(2,603)	(2,516)	(2,516)	(1,839)	(2,306)
2 m	3234	3234	3234	3234	2260	2260	1921	2260	1554	1554	1278	1554	1242	1242	918	1154	1118	1118	762	962
(6' - 7'")	(7,130)	(7,130)	(7,130)	(7,130)	(4,984)	(4,984)	(4,235)	(4,984)	(3,426)	(3,426)	(2,818)	(3,426)	(2,740)	(2,740)	(2,025)	(2,545)	(2,465)	(2,465)	(1,680)	(2,120)
1 m	4961	4961	3414	4641	2571	2571	1762	2283	1703	1703	1199	1524	1291	1291	881	1115	1102	1102	742	941
(3' - 3'")	(10,940)	(10,940)	(7,528)	(10,234)	(5,668)	(5,668)	(3,885)	(5,033)	(3,756)	(3,756)	(2,644)	(3,361)	(2,847)	(2,847)	(1,942)	(2,459)	(2,431)	(2,431)	(1,636)	(2,075)
0 m	4088	4088	3309	4088	2488	2488	1712	2230	1712	1712	1154	1478	1259	1259	858	1091	968	968	771	968
(0' - 0'")	(9,015)	(9,015)	(7,297)	(9,015)	(5,486)	(5,486)	(3,776)	(4,916)	(3,775)	(3,775)	(2,545)	(3,258)	(2,775)	(2,775)	(1,891)	(2,406)	(2,134)	(2,134)	(1,701)	(2,134)
-1 m	3040	3040	3040	3040	2148	2148	1719	2148	1528	1528	1148	1471	-	-	-	-	1027	1027	870	1027
(-3' - 3'")	(6,702)	(6,702)	(6,702)	(6,702)	(4,737)	(4,737)	(3,790)	(4,737)	(3,369)	(3,369)	(2,531)	(3,243)	-	-	-	-	(2,265)	(2,265)	(1,918)	(2,265)
-2 m	2764	2764	2764	2764	1506	1506	1506	1506	1003	1003	1003	1003	-	-	-	-	869	869	869	869
(-6' - 7'")	(6,094)	(6,094)	(6,094)	(6,094)	(3,320)	(3,320)	(3,320)	(3,320)	(2,212)	(2,212)	(2,212)	(2,212)	-	-	-	-	(1,915)	(1,915)	(1,915)	(1,915)

**50: Triple articulation boom/twin tires/stabilizer legs at front/parallel stabilizer blade at rear/long stick**

A \ B	2 m				3 m				4 m				5 m				max			
	(6' - 7'")				(9' - 10'")				(13' - 1'")				(16' - 5'")							
	I	II	III	IV	I	II	III	IV	I	II	III	IV	I	II	III	IV	I	II	III	IV
4 m	-	-	-	-	-	-	-	-	1125	1125	1125	1125	1079	1079	978,8	1079	1083	1083	889	1083
(13' - 1'")	-	-	-	-	-	-	-	-	(2,480)	(2,480)	(2,480)	(2,480)	(2,380)	(2,380)	(2,158)	(2,380)	(2,388)	(2,388)	(1,959)	(2,388)
3 m	-	-	-	-	1523	1523	1523	1523	1255	1255	1255	1255	1106	1106	961	1106	1047	1047	761	958
(9' - 10'")	-	-	-	-	(3,358)	(3,358)	(3,358)	(3,358)	(2,767)	(2,767)	(2,767)	(2,767)	(2,439)	(2,439)	(2,118)	(2,439)	(2,310)	(2,310)	(1,678)	(2,112)
2 m	2823	2823	2823	2823	2078	2078	1968	2078	1466	1466	1290	1466	1186	1186	920	1156	1031	1031	699	886
(6' - 7'")	(6,225)	(6,225)	(6,225)	(6,225)	(4,582)	(4,582)	(4,340)	(4,582)	(3,232)	(3,232)	(2,845)	(3,232)	(2,616)	(2,616)	(2,028)	(2,549)	(2,272)	(2,272)	(1,541)	(1,953)
1 m	4770	4770	3416	4645	2496	2496	1781	2304	1650	1650	1202	1528	1259	1259	876	1111	1020	1017	680	866
(3' - 3'")	(10,518)	(10,518)	(7,532)	(10,243)	(5,503)	(5,503)	(3,927)	(5,080)	(3,639)	(3,639)	(2,650)	(3,369)	(2,775)	(2,775)	(1,932)	(2,449)	(2,250)	(2,242)	(1,500)	(1,910)
0 m	4330	4330	3238	4330	2531	2531	1701	2219	1708	1708	1145	1469	1265	1265	845	1079	1006	1006	703	897
(0' - 0'")	(9,547)	(9,547)	(7,140)	(9,547)	(5,581)	(5,581)	(3,751)	(4,893)	(3,765)	(3,765)	(2,525)	(3,239)	(2,788)	(2,788)	(1,864)	(2,379)	(2,219)	(2,219)	(1,549)	(1,977)
-1 m	3538	3538	3268	3538	2275	2275	1691	2208	1587	1587	1127	1450	1128	1128	838,8	1072	971	971	780	971
(-3' - 3'")	(7,801)	(7,801)	(7,207)	(7,801)	(5,017)	(5,017)	(3,729)	(4,869)	(3,500)	(3,500)	(2,486)	(3,198)	(2,488)	(2,488)	(1,849)	(2,364)	(2,141)	(2,141)	(1,720)	(2,141)
-2 m	2509	2509	2509	2509	1737	1737	1737	1737	1207	1207	1150	1207	-	-	-	-	869	869	869	869
(-6' - 7'")	(5,533)	(5,533)	(5,533)	(5,533)	(3,830)	(3,830)	(3,809)	(3,830)	(2,661)	(2,661)	(2,537)	(2,661)	-	-	-	-	(1,915)	(1,915)	(1,915)	(1,915)

**51: Triple articulation boom/twin tires/transport bar for clamshell bucket at front/parallel stabilizer blade at rear/short stick**

A \ B	2 m				3 m				4 m				5 m				max			
	(6' - 7'")				(9' - 10'")				(13' - 1'")				(16' - 5'")							
	I	II	III	IV	I	II	III	IV	I	II	III	IV	I	II	III	IV	I	II	III	IV
4 m	-	-	-	-	-	-	-	-	1240	1240	1240	1240	-	-	-	-	1190	1190	926	1015
(13' - 1'")	-	-	-	-	-	-	-	-	(2,735)	(2,735)	(2,735)	(2,735)	-	-	-	-	(2,623)	(2,623)	(2,042)	(2,239)
3 m	-	-	-	-	1721	1721	1721	1721	1360	1360	1282	1360	1181	1181	892	978	1141	1141	777	852
(9' - 10'")	-	-	-	-	(3,794)	(3,794)	(3,794)	(3,794)	(2,999)	(2,999)	(2,826)	(2,999)	(2,603)	(2,603)	(1,966)	(2,157)	(2,516)	(2,516)	(1,713)	(1,880)
2 m	3234	3234	3234	3234	2260	2260	1802	2032	1554	1554	1196	1324	1242	1242	856	942	1118	1118	708	778
(6' - 7'")	(7,130)	(7,130)	(7,130)	(7,130)	(4,984)	(4,984)	(3,972)	(4,480)	(3,426)	(3,426)	(2,637)	(2,920)	(2,740)	(2,740)	(1,888)	(2,076)	(2,465)	(2,465)	(1,561)	(1,714)
1 m	4961	4961	3194	3822	2571	2571	1643	1863	1703	1703	1117	1242	1291	1291	819	903	1102	1102	688	757
(3' - 3'")	(10,940)	(10,940)	(7,044)	(8,427)	(5,668)	(5,668)	(3,623)	(4,108)	(3,756)	(3,756)	(2,464)	(2,739)	(2,847)	(2,847)	(1,805)	(1,990)	(2,431)	(2,431)	(1,517)	(1,669)
0 m	4088	4088	3090	3704	2488	2488	1593	1810	1712	1712	1073	1196	1259	1259	795	879	968	968	715	788
(0' - 0'")	(9,015)	(9,015)	(6,813)	(8,167)	(5,486)	(5,486)	(3,513)	(3,991)	(3,775)	(3,775)	(2,365)	(2,636)	(2,775)	(2,775)	(1,754)	(1,938)	(2,134)	(2,134)	(1,576)	(1,737)
-1 m	3040	3040	3040	3040	2148	2148	1600	1817	1528	1528	1066	1189	-	-	-	-	1027	1027	807	892
(-3' - 3'")	(6,702)	(6,702)	(6,702)	(6,702)	(4,737)	(4,737)	(3,528)	(4,007)	(3,369)	(3,369)	(2,351)	(2,621)	-	-	-	-	(2,265)	(2,265)	(1,780)	(1,966)
-2 m	2764	2764	2764	2764	1506	1506	1506	1506	1003	1003	1003	1003	-	-	-	-	869	869	869	869
(-6' - 7'")	(6,094)	(6,094)	(6,094)	(6,094)	(3,320)	(3,320)	(3,320)	(3,320)	(2,212)	(2,212)	(2,212)	(2,212)	-	-	-	-	(1,915)	(1,915)	(1,915)	(1,915)

**52: Triple articulation boom/twin tires/transport bar for clamshell bucket at front/parallel stabilizer blade at rear/long stick**

A B	2 m (6' - 7")				3 m (9' - 10")				4 m (13' - 1")				5 m (16' - 5")				max			
	I	II	III	IV	I	II	III	IV	I	II	III	IV	I	II	III	IV	I	II	III	IV
	4 m (13' - 1")	-	-	-	-	-	-	-	-	1125 (2,480)	1125 (2,480)	1125 (2,480)	1125 (2,480)	1079 (2,380)	1079 (2,380)	916,6 (2,021)	1004 (2,215)	1083 (2,388)	1083 (2,388)	830 (1,830)
3 m (9' - 10")	-	-	-	-	1523 (3,358)	1523 (3,358)	1523 (3,358)	1523 (3,358)	1255 (2,767)	1255 (2,767)	1255 (2,767)	1255 (2,767)	1106 (2,439)	1106 (2,439)	898 (1,981)	986 (2,173)	1047 (2,310)	1047 (2,310)	708 (1,560)	777 (1,712)
2 m (6' - 7")	2823 (6,225)	2823 (6,225)	2823 (6,225)	2823 (6,225)	2078 (4,582)	2078 (4,582)	1849 (4,078)	2078 (4,582)	1466 (3,232)	1466 (3,232)	1208 (2,665)	1338 (2,950)	1186 (2,616)	1186 (2,616)	858 (1,891)	944 (2,080)	1031 (2,272)	1031 (2,272)	648 (1,428)	712 (1,570)
1 m (3' - 3")	4770 (10,518)	4770 (10,518)	3196 (7,048)	3826 (8,437)	2496 (5,503)	2496 (5,503)	1662 (3,664)	2496 (5,503)	1650 (3,639)	1650 (3,639)	1120 (2,470)	1246 (2,747)	1259 (2,775)	1259 (2,775)	814 (1,795)	898 (1,981)	1020 (2,250)	1020 (2,250)	629 (1,388)	693 (1,529)
0 m (0' - 0")	4330 (9,547)	4330 (9,547)	3018 (6,656)	3626 (7,995)	2531 (5,581)	2531 (5,581)	1582 (3,488)	1799 (3,967)	1708 (3,765)	1708 (3,765)	1064 (2,345)	1187 (2,617)	1265 (2,788)	1265 (2,788)	783 (1,727)	866 (1,911)	1006 (2,219)	1006 (2,219)	650 (1,432)	717 (1,580)
-1 m (-3' - 3")	3538 (7,801)	3538 (7,801)	3049 (6,722)	3538 (7,801)	2275 (5,017)	2275 (5,017)	1572 (3,467)	1789 (3,944)	1587 (3,500)	1587 (3,500)	1046 (2,306)	1168 (2,576)	1128 (2,488)	1128 (2,488)	776,6 (1,712)	859,8 (1,896)	971 (2,141)	971 (2,141)	722 (1,593)	798 (1,760)
-2 m (-6' - 7")	2509 (5,533)	2509 (5,533)	2509 (5,533)	2509 (5,533)	1737 (3,830)	1737 (3,830)	1608 (3,546)	1737 (3,830)	1207 (2,661)	1207 (2,661)	1069 (2,357)	1192 (2,629)	-	-	-	-	869 (1,915)	869 (1,915)	869 (1,915)	869 (1,915)

**53: Triple articulation boom/twin tires/parallel stabilizer blade at front/short stick**

A B	2 m (6' - 7")				3 m (9' - 10")				4 m (13' - 1")				5 m (16' - 5")				max			
	I	II	III	IV	I	II	III	IV	I	II	III	IV	I	II	III	IV	I	II	III	IV
	4 m (13' - 1")	-	-	-	-	-	-	-	-	1240 (2,735)	1240 (2,735)	1240 (2,735)	1240 (2,735)	-	-	-	-	1190 (2,623)	1187 (2,617)	939 (2,070)
3 m (9' - 10")	-	-	-	-	1721 (3,794)	1721 (3,794)	1721 (3,794)	1721 (3,794)	1360 (2,999)	1360 (2,999)	1298 (2,862)	1360 (2,999)	1181 (2,603)	1144 (2,523)	904 (1,994)	1181 (2,603)	1141 (2,516)	997 (2,198)	789 (1,739)	1141 (2,516)
2 m (6' - 7")	3234 (7,130)	3234 (7,130)	3234 (7,130)	3234 (7,130)	2260 (4,984)	2260 (4,984)	1826 (4,025)	2260 (4,984)	1554 (3,426)	1554 (3,426)	1213 (2,674)	1554 (3,426)	1242 (2,740)	1106 (2,438)	869 (1,916)	1242 (2,740)	1118 (2,465)	911 (2,009)	719 (1,585)	1052 (2,320)
1 m (3' - 3")	4961 (10,940)	4961 (10,940)	3239 (7,141)	4961 (10,940)	2571 (5,668)	2304 (5,080)	1667 (3,676)	2489 (5,488)	1703 (3,756)	1485 (3,274)	1134 (2,500)	1663 (3,667)	1291 (2,847)	1065 (2,347)	831 (1,833)	1220 (2,689)	1102 (2,431)	890 (1,962)	699 (1,541)	1031 (2,274)
0 m (0' - 0")	4088 (9,015)	4088 (9,015)	3134 (6,911)	4088 (9,015)	2488 (5,486)	2245 (4,950)	1617 (3,566)	2436 (5,372)	1712 (3,775)	1435 (3,164)	1089 (2,402)	1616 (3,564)	1259 (2,775)	1039 (2,292)	808 (1,782)	1196 (2,636)	968 (2,134)	928 (2,047)	726 (1,601)	968 (2,134)
-1 m (-3' - 3")	3040 (6,702)	3040 (6,702)	3040 (6,702)	3040 (6,702)	2148 (4,737)	2148 (4,737)	1624 (3,581)	2148 (4,737)	1528 (3,369)	1427 (3,147)	1083 (2,387)	1528 (3,369)	-	-	-	-	1027 (2,265)	1027 (2,265)	820 (1,808)	1027 (2,265)
-2 m (-6' - 7")	2764 (6,094)	2764 (6,094)	2764 (6,094)	2764 (6,094)	2764 (6,094)	2764 (6,094)	1506 (3,320)	2764 (6,094)	1506 (3,320)	1003 (2,212)	1003 (2,212)	1003 (2,212)	-	-	-	-	869 (1,915)	869 (1,915)	869 (1,915)	869 (1,915)

**54: Triple articulation boom/twin tires/parallel stabilizer blade at front/long stick**

A B	2 m (6' - 7")				3 m (9' - 10")				4 m (13' - 1")				5 m (16' - 5")				max			
	I	II	III	IV	I	II	III	IV	I	II	III	IV	I	II	III	IV	I	II	III	IV
	4 m (13' - 1")	-	-	-	-	-	-	-	-	1125 (2,480)	1125 (2,480)	1125 (2,480)	1125 (2,480)	1079 (2,380)	1079 (2,380)	929,1 (2,049)	1079 (2,380)	1083 (2,388)	1063 (2,344)	842 (1,856)
3 m (9' - 10")	-	-	-	-	1523 (3,358)	1523 (3,358)	1523 (3,358)	1523 (3,358)	1255 (2,767)	1255 (2,767)	1255 (2,767)	1255 (2,767)	1106 (2,439)	1106 (2,439)	911 (2,009)	1106 (2,439)	1047 (2,310)	909 (2,004)	718 (1,584)	1047 (2,308)
2 m (6' - 7")	2823 (6,225)	2823 (6,225)	2823 (6,225)	2823 (6,225)	2078 (4,582)	2078 (4,582)	1873 (4,131)	2078 (4,582)	1466 (3,232)	1466 (3,232)	1225 (2,701)	1466 (3,232)	1186 (2,616)	1108 (2,444)	870 (1,919)	1186 (2,616)	1031 (2,272)	836 (1,843)	658 (1,451)	971 (2,141)
1 m (3' - 3")	4770 (10,518)	4770 (10,518)	3240 (7,145)	4770 (10,518)	2496 (5,503)	2329 (5,135)	1686 (3,717)	2496 (5,503)	1650 (3,639)	1490 (3,286)	1137 (2,507)	1650 (3,639)	1259 (2,775)	1061 (2,339)	826 (1,822)	1215 (2,680)	1020 (2,250)	816 (1,799)	640 (1,410)	951 (2,098)
0 m (0' - 0")	4330 (9,547)	4330 (9,547)	3063 (6,753)	4330 (9,547)	2531 (5,581)	2235 (4,928)	1606 (3,541)	2425 (5,348)	1708 (3,765)	1427 (3,146)	1080 (2,382)	1608 (3,545)	1265 (2,788)	1027 (2,265)	796 (1,754)	1183 (2,609)	1006 (2,219)	845 (1,864)	660 (1,456)	985 (2,172)
-1 m (-3' - 3")	3538 (7,801)	3538 (7,801)	3093 (6,820)	3538 (7,801)	2275 (5,017)	2223 (4,902)	1596 (3,519)	2275 (5,017)	1587 (3,500)	1407 (3,102)	1062 (2,342)	1587 (3,500)	1128 (2,488)	1020 (2,250)	789,1 (1,740)	1128 (2,488)	971 (2,141)	944 (2,081)	734 (1,618)	971 (2,141)
-2 m (-6' - 7")	2509 (5,533)	2509 (5,533)	2509 (5,533)	2509 (5,533)	1737 (3,830)	1737 (3,830)	1632 (3,599)	1737 (3,830)	1207 (2,661)	1207 (2,661)	1085 (2,393)	1207 (2,661)	-	-	-	-	869 (1,915)	869 (1,915)	869 (1,915)	869 (1,915)



55: Triple articulation boom/twin tires/stabilizer blade at front/short stick

A \ B	2 m				3 m				4 m				5 m				max			
	(6' - 7'")				(9' - 10'")				(13' - 1'")				(16' - 5'")							
	I	II	III	IV	I	II	III	IV	I	II	III	IV	I	II	III	IV	I	II	III	IV
4 m	-	-	-	-	-	-	-	-	1240	1240	1240	1240	-	-	-	-	1190	1190	919	1190
(13' - 1'")	-	-	-	-	-	-	-	-	(2,735)	(2,735)	(2,735)	(2,735)	-	-	-	-	(2,623)	(2,623)	(2,026)	(2,623)
3 m	-	-	-	-	1721	1721	1721	1721	1360	1360	1272	1360	1181	1163	885	1181	1141	1014	771	1078
(9' - 10'")	-	-	-	-	(3,794)	(3,794)	(3,794)	(3,794)	(2,999)	(2,999)	(2,806)	(2,999)	(2,603)	(2,564)	(1,951)	(2,603)	(2,516)	(2,235)	(1,699)	(2,377)
2 m	3234	3234	3234	3234	2260	2260	1788	2260	1554	1554	1187	1554	1242	1124	849	1189	1118	927	702	992
(6' - 7'")	(7,130)	(7,130)	(7,130)	(7,130)	(4,984)	(4,984)	(3,943)	(4,984)	(3,426)	(3,426)	(2,617)	(3,426)	(2,740)	(2,479)	(1,873)	(2,622)	(2,465)	(2,045)	(1,547)	(2,187)
1 m	4961	4961	3170	4776	2571	2343	1630	2352	1703	1510	1108	1571	1291	1083	812	1150	1102	906	682	971
(3' - 3'")	(10,940)	(10,940)	(6,990)	(10,532)	(5,668)	(5,165)	(3,593)	(5,186)	(3,756)	(3,329)	(2,444)	(3,463)	(2,847)	(2,388)	(1,790)	(2,536)	(2,431)	(1,997)	(1,504)	(2,141)
0 m	4088	4088	3065	4088	2488	2284	1580	2299	1712	1460	1064	1524	1259	1058	788	1126	968	945	709	968
(0' - 0'")	(9,015)	(9,015)	(6,759)	(9,015)	(5,486)	(5,036)	(3,484)	(5,069)	(3,775)	(3,219)	(2,345)	(3,361)	(2,775)	(2,333)	(1,739)	(2,483)	(2,134)	(2,083)	(1,562)	(2,134)
-1 m	3040	3040	3040	3040	2148	2148	1587	2148	1528	1453	1057	1517	-	-	-	-	1027	1027	800	1027
-(3' - 3'")	(6,702)	(6,702)	(6,702)	(6,702)	(4,737)	(4,737)	(3,498)	(4,737)	(3,369)	(3,203)	(2,331)	(3,345)	-	-	-	-	(2,265)	(2,265)	(1,765)	(2,265)
-2 m	2764	2764	2764	2764	1506	1506	1506	1506	1003	1003	1003	1003	-	-	-	-	869	869	869	869
-(6' - 7'")	(6,094)	(6,094)	(6,094)	(6,094)	(3,320)	(3,320)	(3,320)	(3,320)	(2,212)	(2,212)	(2,212)	(2,212)	-	-	-	-	(1,915)	(1,915)	(1,915)	(1,915)

56: Triple articulation boom/twin tires/stabilizer blade at front/long stick

A \ B	2 m				3 m				4 m				5 m				max			
	(6' - 7'")				(9' - 10'")				(13' - 1'")				(16' - 5'")							
	I	II	III	IV	I	II	III	IV	I	II	III	IV	I	II	III	IV	I	II	III	IV
4 m	-	-	-	-	-	-	-	-	1125	1125	1125	1125	1079	1079	909,6	1079	1083	1081	823	1083
(13' - 1'")	-	-	-	-	-	-	-	-	(2,480)	(2,480)	(2,480)	(2,480)	(2,380)	(2,380)	(2,006)	(2,380)	(2,388)	(2,383)	(1,816)	(2,388)
3 m	-	-	-	-	1523	1523	1523	1523	1255	1255	1255	1255	1106	1106	891	1106	1047	925	702	988
(9' - 10'")	-	-	-	-	(3,358)	(3,358)	(3,358)	(3,358)	(2,767)	(2,767)	(2,767)	(2,767)	(2,439)	(2,439)	(1,966)	(2,439)	(2,310)	(2,039)	(1,547)	(2,178)
2 m	2823	2823	2823	2823	2078	2078	1836	2078	1466	1466	1199	1466	1186	1127	851	1186	1031	851	642	914
(6' - 7'")	(6,225)	(6,225)	(6,225)	(6,225)	(4,582)	(4,582)	(4,048)	(4,582)	(3,232)	(3,232)	(2,644)	(3,232)	(2,616)	(2,485)	(1,876)	(2,616)	(2,272)	(1,876)	(1,416)	(2,016)
1 m	4770	4770	3172	4770	2496	2368	1648	2373	1650	1515	1111	1575	1259	1080	807	1146	1020	831	624	895
(3' - 3'")	(10,518)	(10,518)	(6,993)	(10,518)	(5,503)	(5,221)	(3,635)	(5,232)	(3,639)	(3,341)	(2,450)	(3,472)	(2,775)	(2,380)	(1,779)	(2,526)	(2,250)	(1,832)	(1,375)	(1,973)
0 m	4330	4330	2994	4330	2531	2274	1569	2288	1708	1452	1054	1515	1265	1046	776	1114	1006	861	644	926
(0' - 0'")	(9,547)	(9,547)	(6,601)	(9,547)	(5,581)	(5,013)	(3,459)	(5,045)	(3,765)	(3,201)	(2,325)	(3,341)	(2,788)	(2,306)	(1,711)	(2,456)	(2,219)	(1,899)	(1,419)	(2,043)
-1 m	3538	3538	3024	3538	2275	2262	1559	2275	1587	1432	1037	1497	1128	1039	769,6	1107	971	961	716	971
-(3' - 3'")	(7,801)	(7,801)	(6,668)	(7,801)	(5,017)	(4,988)	(3,437)	(5,017)	(3,500)	(3,157)	(2,286)	(3,300)	(2,488)	(2,291)	(1,697)	(2,442)	(2,141)	(2,119)	(1,578)	(2,141)
-2 m	2509	2509	2509	2509	1737	1737	1595	1737	1207	1207	1060	1207	-	-	-	-	869	869	869	869
-(6' - 7'")	(5,533)	(5,533)	(5,533)	(5,533)	(3,830)	(3,830)	(3,517)	(3,830)	(2,661)	(2,661)	(2,336)	(2,661)	-	-	-	-	(1,915)	(1,915)	(1,915)	(1,915)

## Safety instructions load diagrams

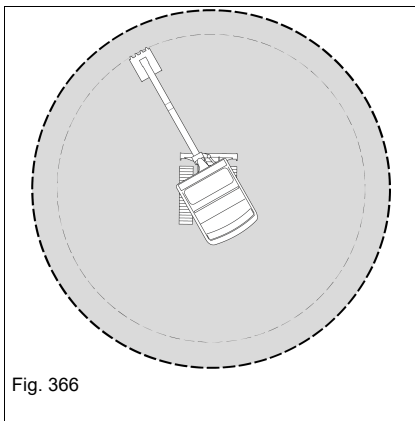
Observe the values of the load diagrams in lifting gear applications.

### **DANGER**

#### **Crushing hazard due to tipping over of vehicle!**

The vehicle causes serious injury or death when it tips over.

- ▶ Do not exceed the weights indicated in the load diagrams.
- ▶ Subtract the weight of the attachment from the weight specified in the relevant load diagram.
- ▶ Use the vehicle for lifting gear applications only if the mandatory lifting gear and safety equipment is installed, functional and enabled.
- ▶ The arm system must stand straight to the cabin - see [Fig. 366](#).



### **NOTICE**

If the weight is exceeded, there is a risk of damage to property if the machine tips over.

- ▶ Do not exceed the weights indicated in the load diagrams.

### **Information**

The indications are only approximate values. Attachments, uneven ground and soft or bad ground conditions affect the vehicle's stability, and thus the weight and mass it can handle. The operator must take these influences into account.



**Legend**

Description	Explanation
X	Reach from live ring center
Z	Load hook height in the respective range
max	Authorized lift capacity with horizontal boom
L	Stick short/long

Authorized lift capacity applies to entire swiveling range of 360°.

All table indications in kg (lbs.) and horizontal position on firm and level ground without bucket or exchangeable attachment.

The vehicle's lift capacity is restricted by the settings of the pressure limiting valves, the hydraulic output and the hydraulic system's stabilizing features.

Neither 75% of the static tilt load nor 87% of the hydraulic lift capacity is exceeded.

Calculation basis: according to ISO 10567.

ET65: 24,000 kPA (3481 psi)

ET90: 30,000 kPA (4351 psi)

Lift capacities apply to vehicles under the following conditions:

- Lubricants and engine/vehicle fluids at the mandatory levels
- Full fuel tank
- Cab
- Machine at operating temperature
- Operator weight 75 kg (165 lbs.)



**EW65: single tires/triple boom**

Type/version:  
**E14-02**

**WARNING**

Using machine as lifting gear can cause serious injury or death. Always read Operator's Manual before using machine as lifting gear.

**WARNING**

**TIP-OVER HAZARD**

Never allow total load to exceed excavator lift capacity.

**ISO 10567**

**L = 1685 mm (5.5 ft)**

z	x	3m (9.8ft)	4m (13.1ft)	5m (16.4ft)	max
<b>Z2</b>	$\frac{kg}{lb}$	1420 kg (3,131 lbs)	970 kg (2,139 lbs)	709 kg (1,563 lbs)	594 kg (1,310 lbs)
<b>Z1</b>	$\frac{kg}{lb}$	1371 kg (3,023 lbs)	919 kg (2,027 lbs)	686 kg (1,513 lbs)	594 kg (1,310 lbs)
<b>Z3</b>	$\frac{kg}{lb}$	1378 kg (3,037 lbs)	919 kg (2,027 lbs)	-	697 kg (1,538 lbs)

**L = 1985 mm (6.5 ft)**

z	x	3m (9.8ft)	4m (13.1ft)	5m (16.4ft)	max
<b>Z2</b>	$\frac{kg}{lb}$	1438 kg (3,170 lbs)	973 kg (2,145 lbs)	704 kg (1,553 lbs)	541 kg (1,192 lbs)
<b>Z1</b>	$\frac{kg}{lb}$	1350 kg (2,977 lbs)	899 kg (1,983 lbs)	674 kg (1,485 lbs)	541 kg (1,192 lbs)
<b>Z3</b>	$\frac{kg}{lb}$	1350 kg (2,977 lbs)	899 kg (1,983 lbs)	667 kg (1,471 lbs)	621 kg (1,369 lbs)

Version 00 1000350280

**EW65: twin tires/triple articulation boom**

Type/version:  
**E14-02**

**WARNING**

Using machine as lifting gear can cause serious injury or death. Always read Operator's Manual before using machine as lifting gear.

**WARNING**

**TIP-OVER HAZARD**

Never allow total load to exceed excavator lift capacity.

**ISO 10567**

**L = 1685 mm (5.5 ft)**

z	x	3m (9.8ft)	4m (13.1ft)	5m (16.4ft)	max
<b>Z2</b>	$\frac{kg}{lb}$	1605 kg (3,539 lbs)	1091 kg (2,406 lbs)	799 kg (1,761 lbs)	671 kg (1,479 lbs)
<b>Z1</b>	$\frac{kg}{lb}$	1555 kg (3,429 lbs)	1040 kg (2,293 lbs)	776 kg (1,710 lbs)	671 kg (1,479 lbs)
<b>Z3</b>	$\frac{kg}{lb}$	1506 kg (3,320 lbs)	1003 kg (2,212 lbs)	-	787 kg (1,736 lbs)

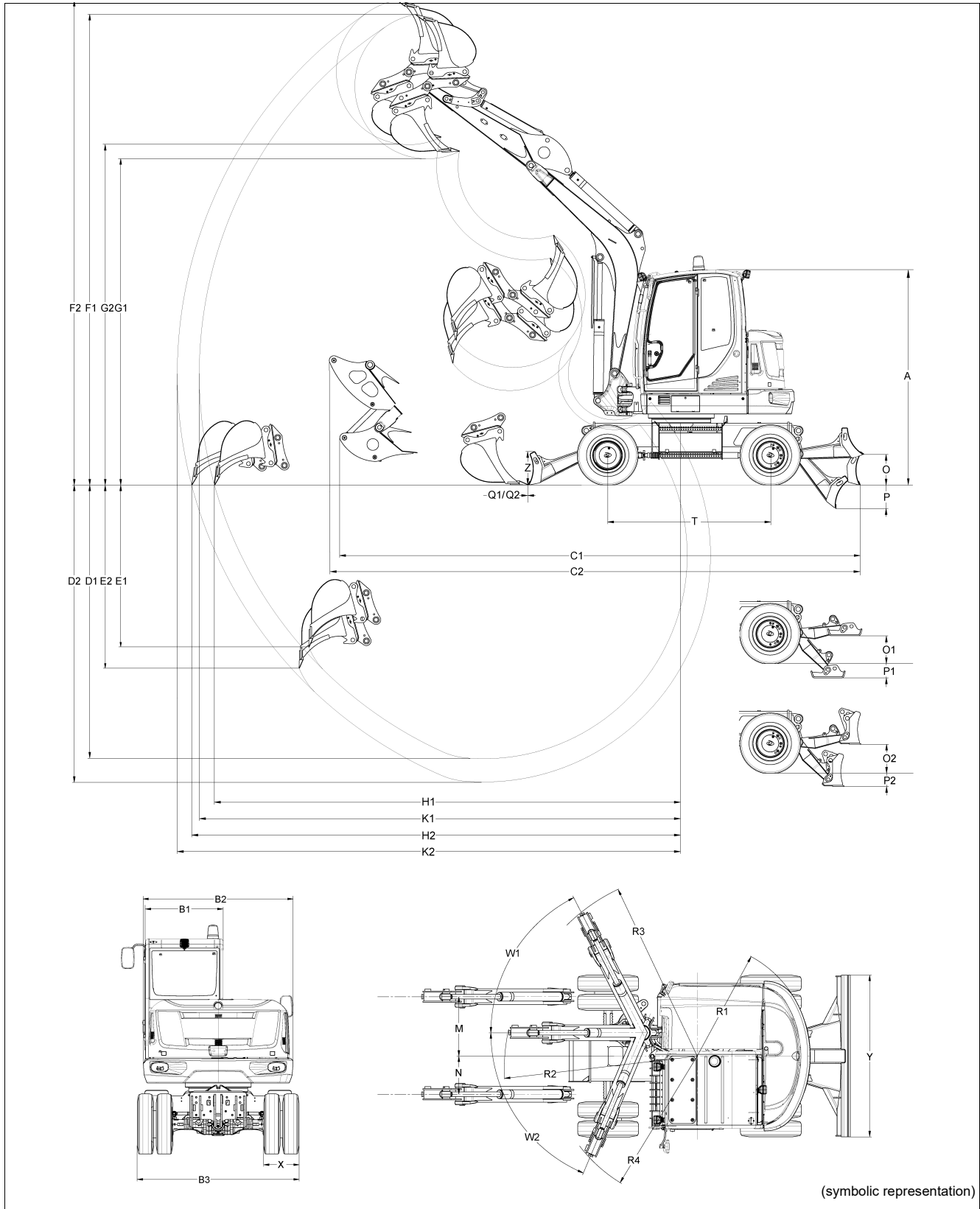
**L = 1985 mm (6.5 ft)**

z	x	3m (9.8ft)	4m (13.1ft)	5m (16.4ft)	max
<b>Z2</b>	$\frac{kg}{lb}$	1523 kg (3,358 lbs)	1094 kg (2,413 lbs)	794 kg (1,751 lbs)	613 kg (1,352 lbs)
<b>Z1</b>	$\frac{kg}{lb}$	1534 kg (3,383 lbs)	1020 kg (2,248 lbs)	763 kg (1,683 lbs)	613 kg (1,352 lbs)
<b>Z3</b>	$\frac{kg}{lb}$	1534 kg (3,383 lbs)	1020 kg (2,248 lbs)	757 kg (1,669 lbs)	704 kg (1,552 lbs)

Version 00 1000350291

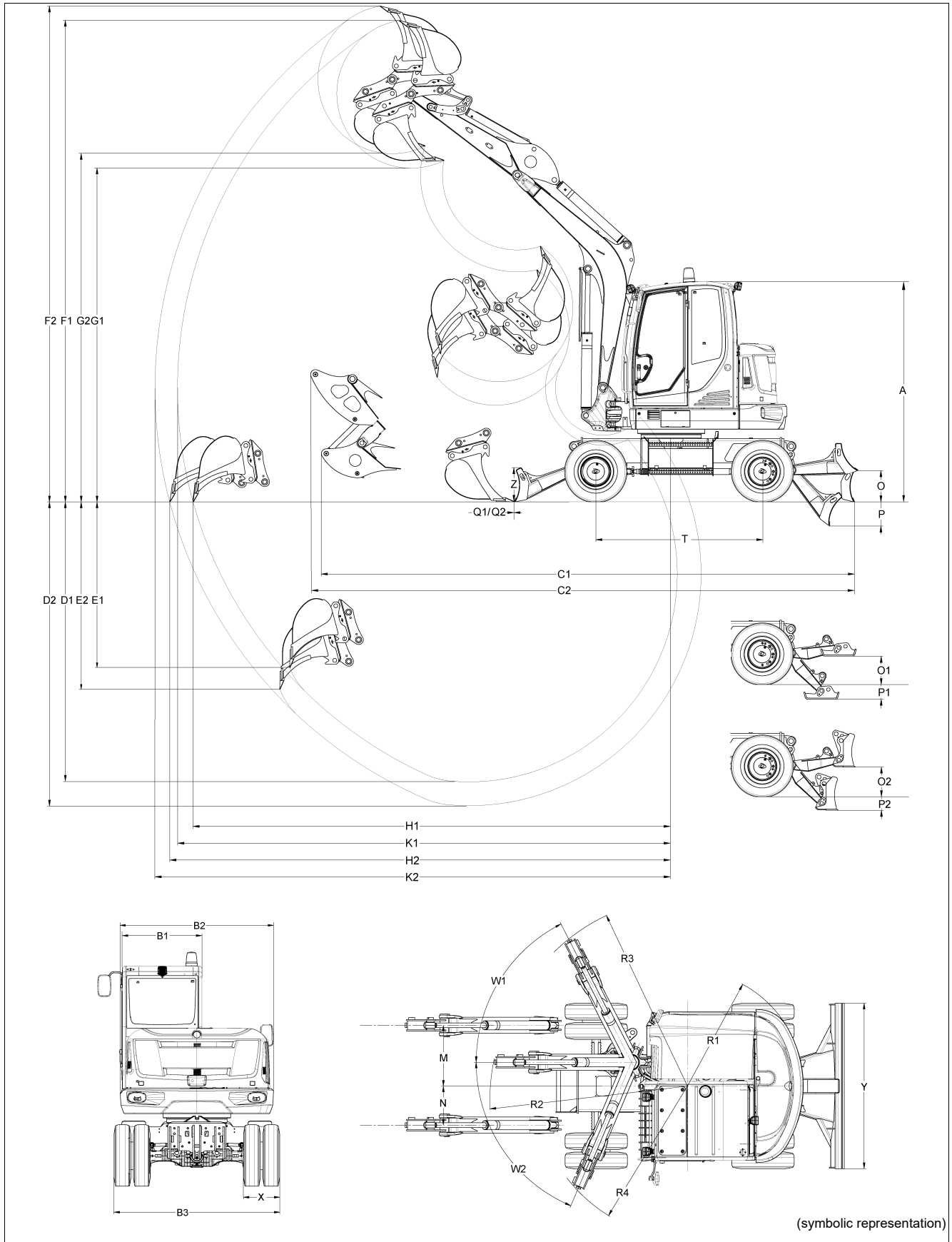
## 9.15 Dimensions

### Overview EW65 (one-piece boom)



	<b>EW65 (one-piece boom)</b>	<b>Dimensions mm (in)</b>
A	Height	2775 (9'-1")
B1	Cabin width	1000 (39)
B2	Upper carriage width	1931 (76)
B3	Width of travel gear with single tires 300	1832 (72)
	Width of travel gear with single tires 425	2001 (79)
	Travel gear width with twin tires	2088 (82)
C1	Transport length with stabilizer blade (short stick)	6114 (20'-1")
C2	Transport length with stabilizer blade (long stick)	6137 (20'-6")
D1	Max. digging depth (short stick)	3531 (11'-7")
D2	Max. digging depth (long stick)	3831 (12'-9")
E1	Max. vertical digging depth (short stick)	2088 (82)
E2	Max. vertical digging depth (long stick)	2361 (93)
F1	Max. digging height (short stick)	6068 (19'-11")
F2	Max. digging height (long stick)	6250 (20'-6")
G1	Max. tilt-out height (short stick)	4207 (13'-10")
G2	Max. tilt-out height (long stick)	4389 (14'-5")
H1	Max. reach at ground level (short stick)	6024 (19'-9")
H2	Max. reach at ground level (long stick)	6318 (20'-9")
K1	Max. digging radius (short stick)	6220 (20'-5")
K2	Max. digging radius (long stick)	6504 (21'-4")
M	Max. boom displacement to bucket center (right side)	766 (30)
N	Max. boom displacement to bucket center (left side)	492 (19)
O	Max. lift height of stabilizer blade over ground	395 (16)
O1	Max. lift height of stabilizer legs over subgrade	357 (14)
O2	Max. lift height of parallel stabilizer blade over ground	371 (15)
P	Max. scraping depth of stabilizer blade below ground surface	301 (12)
P1	Max. scraping depth of stabilizer legs below subgrade	186 (7)
P2	Max. scraping depth of parallel dozer blade below subgrade	172 (7)
Q1	Distance between bucket and stabilizer blade (short stick)	0
Q2	Distance between bucket and stabilizer blade (long stick)	0
R1	Min. tail end swiveling radius	1459 (57)
R2	Boom swivel radius (center)	2465 (97)
R3	Boom swivel radius (right)	2393 (94)
R4	Boom swivel radius (left)	1940 (76)
T	Wheelbase	2100 (83)
W1	Max. tilting angle of boom to the right	63°
W2	Max. tilting angle of boom to the left	67°
X	Wheel width of individual tires 300	300 (12)
	Wheel width of individual tires 425	425 (17)
	Wheel width of twin tires	457 (18)
Y	Stabilizer blade width	2085 (82)
Z	Stabilizer blade height	429 (17)

**Overview EW65 (triple articulation boom)**





	<b>EW65 (triple articulation boom)</b>	<b>Dimensions mm (in)</b>
A	Height	2775 (9'-1")
B1	Cabin width	1000 (39)
B2	Upper carriage width	1931 (76)
B3	Width of travel gear with single tires 300	1832 (72)
	Width of travel gear with single tires 425	2001 (79)
	Travel gear width with twin tires	2088 (82)
C1	Transport length with stabilizer blade (short stick)	6220 (20'-5")
C2	Transport length with stabilizer blade (long stick)	6349 (20'-10")
D1	Max. digging depth (short stick)	3596 (11'-10")
D2	Max. digging depth (long stick)	3895 (12'-9")
E1	Max. vertical digging depth (short stick)	2465 (97)
E2	Max. vertical digging depth (long stick)	2737 (8'-12")
F1	Max. digging height (short stick)	6834 (22'-5")
F2	Max. digging height (long stick)	7067 (23'-2")
G1	Max. tilt-out height (short stick)	4961 (16'-3")
G2	Max. tilt-out height (long stick)	5195 (17'-1")
H1	Max. reach at ground level (short stick)	6406 (21'-0")
H2	Max. reach at ground level (long stick)	6706 (22'-0")
K1	Max. digging radius (short stick)	6590 (21'-7")
K2	Max. digging radius (long stick)	6877 (22'-7")
M	Max. boom displacement to bucket center (right side)	766 (30)
N	Max. boom displacement to bucket center (left side)	492 (19)
O	Max. lift height of stabilizer blade over ground	395 (16)
O1	Max. lift height of stabilizer legs over subgrade	357 (14)
O2	Max. lift height of parallel stabilizer blade over ground	371 (15)
P	Max. scraping depth of stabilizer blade below ground surface	301 (12)
P1	Max. scraping depth of stabilizer legs below subgrade	186 (7)
P2	Max. scraping depth of parallel dozer blade below subgrade	172 (7)
Q1	Distance between bucket and stabilizer blade (short stick)	514 (20)
Q2	Distance between bucket and stabilizer blade (long stick)	384 (15)
R1	Min. tail end swiveling radius	1459 (57)
R2	Boom swivel radius (center)	2605 (8'-7")
R3	Boom swivel radius (right)	2529 (100)
R4	Boom swivel radius (left)	2073 (82)
T	Wheelbase	2100 (83)
W1	Max. tilting angle of boom to the right	63°
W2	Max. tilting angle of boom to the left	67°
X	Wheel width of individual tires 300	300 (12)
	Wheel width of individual tires 425	425 (17)
	Wheel width of twin tires	457 (18)
Y	Stabilizer blade width	2085 (82)
Z	Stabilizer blade height	429 (17)



Notes:

# Index

**Numerisch**

12 V connection ..... 4-28

**A**

Abbreviations ..... 1-3

Adding coolant ..... 7-44

Adding hydraulic oil ..... 7-49

Additional control circuit – AUX I ..... 5-46, 5-51

Additional control circuits ..... 5-47

Adjusting the steering column ..... 4-22

Adjustment of air-suspension seat

Weight adjustment ..... 4-11, 4-15

Air conditioning ..... 7-53

Air filter ..... 7-46

Air intake ..... 7-46

Arm rest ..... 4-23

Attachments ..... 5-76, 9-15

Application areas and use ..... 9-14

Changing with Easy Lock ..... 5-68

Picking up ..... 5-76

Picking up with Easy Lock ..... 5-61

Setting down ..... 5-77

Setting down with Easy Lock ..... 5-65

Automatic engine speed setting ..... 5-5

AUX ..... 5-47, 5-48

AUX V ..... 5-71

Axles ..... 7-53

**B**

Battery ..... 7-53

Battery master switch ..... 4-57

Bleeding the fuel system ..... 7-39

Brake ..... 5-6

Brakes

Hydraulic brake ..... 5-7

Hydraulic swivel unit brake ..... 5-40

Mechanical brake ..... 5-8

Swivel unit brake ..... 5-40

Brief description of the vehicle ..... 3-2

Bulbs ..... 9-10

**C**

Cabin ..... 4-1, 4-30

Changing ..... 5-68

Changing rpm

Throttle/idling speed ..... 5-5

Check belt tension ..... 7-47

Check lists ..... 4-46

Check the coolant level ..... 7-44

Check the hydraulic oil level ..... 7-48

Checking the hydraulic system and hoses ..... 7-50

Checking the water separator ..... 7-37

Cleaning and maintenance ..... 7-29

Cleaning the radiator ..... 7-45

Control elements ..... 4-29

Control lever base ..... 4-51

Conversion table ..... 1-7

Coolant

Compound table ..... 9-12

Show temperature ..... 4-40

Coolant compound table ..... 9-12

Cooling system ..... 7-43

Crane-lifting ..... 6-9

**D**

Danger zone ..... 5-80

Designated use ..... 3-4

Dimensions ..... 9-44

Display element ..... 4-36

Displaying operating states ..... 4-41

Document box ..... 4-28

DPF

Automatic regeneration ..... 7-65

Control elements ..... 7-65

Diesel particulate filter ..... 7-59, 7-68

Extend regeneration intervals ..... 7-62, 7-70

Indication of load ..... 7-71

Indicator lights ..... 7-71

Load condition ..... 7-64, 7-69

Manual regeneration ..... 7-66

Parking the vehicle ..... 7-67

Types of regeneration ..... 7-62, 7-70

Drive interlock ..... 5-89

Driving license ..... 3-5

**E**

EC Declaration of Conformity ..... EG-1

Electrical components ..... 9-6

Electrical system ..... 7-52

Emergency exit ..... 4-9

Emergency lowering ..... 5-88

Empty the water separator (main filter) ..... 7-38

Empty the water separator (prefilter) ..... 7-37

Engine

Low-load operation ..... 4-56

Operation mode ..... 5-2

Starting aid ..... 4-53

Starting and stopping ..... 4-50

Warm-up phase ..... 4-52

Engine oil

Check the oil level ..... 7-41

Top off ..... 7-42

Equipment ..... 3-5

Error symbols ..... 4-39

Excavator forces ..... 9-16

Explanation of symbols ..... 1-2

**F**

Fire extinguisher ..... 4-23



Fluids and lubricants .....	7-21	Lift capacity tables .....	9-17
Biodegradable hydraulic oil .....	7-24	Lift capacity/load .....	9-17
FOPS type label .....	3-10	Lifting .....	5-52
Foreword .....	1-1	Lifting eyes .....	6-10
Forward-reverse control .....	5-10	Lifting gear applications .....	5-52
Front Guard emergency exit .....	4-9	Danger zone .....	5-81
Front stabilizer blade .....	5-18	Safe load indicator .....	5-53
Front window		Lights	
Operation .....	4-4	Boom light .....	5-29
Fuel filter .....	7-37	Chassis headlights (option) .....	5-30
Fuel level indicator .....	4-40	Interior light .....	5-32
Fuel system .....	7-32	Operating the lighting system .....	5-31
Functional check		Roof lights (option) .....	5-30
Brake test .....	5-8	Rotating beacon .....	5-32
Control lever base .....	4-51	Load diagrams .....	9-40
Swivel unit brake .....	5-40	Loading .....	6-7
Fuses .....	9-8	Loading the vehicle .....	6-7
Cabin fuse box .....	9-8	Loading vehicles .....	5-86
Main fuse box .....	9-6	Lubrication .....	7-9, 7-31
<b>G</b>		Attachment mounts .....	7-16
Getting on and off .....	4-2	Cab .....	7-16
Glossary .....	1-4	Control lever base .....	7-18
Right/left/front/rear .....	1-5	Live ring (ball bearing) .....	7-17
Grab .....	5-17	Machine with triple articulation boom .....	7-12
Grab operation .....	5-71	Operation in water .....	7-20
Ground clearance .....	9-17	Lubrication plan	
<b>H</b>		One-piece boom .....	7-10
Hammer .....	5-44	Triple articulation boom .....	7-12
Hammer operation .....	5-44	<b>M</b>	
Interval for changing the hydraulic oil .....	7-22	Machine inspections .....	3-5
Job site .....	5-45	Machine overview .....	3-1
Hazard warning system .....	5-31	Machine travel .....	5-9
Heating .....	5-35, 7-53	Machine travel on slopes .....	5-26
Hose burst valve .....	5-74	Maintenance	
Hose burst valve "Advanced" .....	5-74	Maintenance flap .....	7-28
Hydraulic connections .....	5-73	Maintenance label .....	7-2
Hydraulic oil types .....	7-22	Maintenance meter .....	4-41
Hydraulic quickhitch		Maintenance accesses .....	7-25
Easy Lock .....	5-60	Maintenance of attachments .....	7-58
Hydraulic system .....	7-47	Maintenance of the electrical system .....	7-52
<b>I</b>		Maintenance plan	
Ignition lock .....	4-50	MSWS Lehnhoff .....	7-8
Inadmissible work procedures .....	5-82	Vehicle .....	7-4
Indicator lights and warning lights .....	4-36	Malfunctions .....	8-1
Information and regulations on use .....	3-4	Diesel engine .....	8-1
Information labels .....	3-16	Manual throttle .....	5-1
Information on this Operator's Manual .....	1-1	Model designations and trade names .....	3-2
Interior light .....	5-32	MSWS Lehnhoff (Option) .....	5-55
Introduction .....	3-1	Picking up an attachment .....	5-56
ISO/SAE controls (option) .....	5-38	Setting down an attachment .....	5-58
<b>J</b>		Multi-functional display	
Jog Dial .....	4-34	Display settings .....	4-44
<b>L</b>		<b>N</b>	
Labels .....	3-6	Noise emissions .....	9-12
		<b>O</b>	



One-piece boom .....	5-16
Opening/closing the engine hood .....	7-26
Opening/closing the side window .....	4-7
Opening/closing the valve cover .....	7-27
Operating temperature range .....	5-22
Operation .....	5-1
Operation checklist .....	4-48
Operation in water .....	5-84
Operation near the sea .....	5-84
Operator seat	
Air-sprung (option) .....	4-13
Comfort seat .....	4-10
Options .....	5-89
Overspeed .....	5-7
<b>P</b>	
Parking checklist .....	4-48
Parking the vehicle .....	5-27
Parking the vehicle on slopes .....	5-28
Powertilt .....	9-10
Proportional controls .....	5-49
Protective FOPS screen .....	4-25
Protective structures .....	4-24
Putting back into operation .....	5-94
Putting into operation .....	4-1
Putting into operation for the first time and running-in	

period .....	4-49	Vibration .....	9-12
Putting out of operation		Visual aids .....	4-18
Disposal .....	5-95	<b>W</b>	
Final .....	5-95	Warning labels .....	3-11
Temporarily .....	5-93	Warranty and liability .....	1-8
<b>R</b>		Washer system	
Re-equipping .....	5-79	Checking and topping off .....	7-53
Refueling .....	7-33	Weight	
Fuel-filling pump .....	7-35	Attachments .....	9-15
Stationary fuel pump .....	7-34	Weight adjustment of seat .....	4-10, 4-13
Replacing the cabin air filter .....	7-53	Weights .....	9-13
Retracting seat belt .....	4-17	Wiper/wash system	
Road travel		Operation .....	5-34
Aligning the boom .....	5-16	Work hydraulics .....	5-37, 9-4
Rotating the upper carriage .....	5-39	Pressure relief .....	5-78
<b>S</b>		Work operation .....	5-80
Safe load indicator		Working	
Functional check .....	5-53	Excavating .....	5-85
Seat adjustment		Grading .....	5-86
Headrest .....	4-11	Hydraulic hammer .....	5-45
Serial number of vehicle .....	3-7	Loading material .....	5-86
Service menu/error messages .....	8-7	Slopes .....	5-87
Shovel bucket operation .....	5-92		
Stabilizer legs/stabilizer blade .....	5-42		
Starting aid .....	4-53		
Start-up checklist .....	4-47		
Steering system .....	9-4		
Sun blind .....	4-8		
Swivel unit brake .....	5-40		
Swiveling the boom .....	5-51		
<b>T</b>			
Technical data			
Brake .....	9-3		
Engine .....	9-1		
Maximum speed .....	9-5		
Tires .....	9-4		
Travel drive .....	9-3		
Tie-down points .....	6-7		
Tightening torques .....	9-10		
Towing .....	6-1		
Transportation .....	6-1		
Transporting the vehicle .....	6-12		
Travel drive .....	7-53		
Travel signal (option) .....	5-33		
Triple articulation boom .....	5-16		
Type labels .....	3-7		
Cabin number .....	3-10		
FOPS screen .....	3-10		
Front Guard .....	3-10		
<b>U</b>			
Unlocking and locking the door .....	4-2		
<b>V</b>			
V-belt .....	7-47		
Ventilation .....	5-35, 7-53		



# SAFETY MANUAL

FOR OPERATING AND MAINTENANCE PERSONNEL



## Contents

Acknowledgment .....	2
Foreword .....	3
Safety Alerts .....	4
One-Call First .....	5
A Word To The User/Operator .....	6
Follow A Safety Program .....	7
Prepare For Safe Operation .....	13
Start Safely .....	22
Operate Safely .....	26
Shut Down Safely .....	39
Load And Unload The Machine Safely .....	40
Perform Maintenance Safely .....	41
Final Word To The User .....	51

## Acknowledgment

We wish to acknowledge the contributions of the members of AEM's Compact Loader/Compact Excavator Council to the preparation of this Safety Manual.

### NOTICE OF COPYRIGHT PROTECTION

Copyright, 2010, by the Association of Equipment Manufacturers. All rights reserved. This work may not be reproduced or disseminated in whole or in part by any means without the prior written permission of the Association of Equipment Manufacturers.

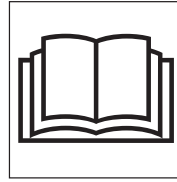
Copyright 2002-2010© AEM (Association of Equipment Manufacturers)  
Revised 05/03, 09/10

# Foreword

This safety manual is intended to point out some of the basic safety situations that may be encountered during the normal operation and maintenance of the machine and to suggest possible ways of dealing with these conditions. This manual is **NOT** a substitute for the compact excavator manufacturer's operator manual(s).

Additional precautions may be necessary, or some instructions may not apply, depending on equipment, attachments and conditions at the worksite or in the service area. The manufacturer has no direct control over equipment application, operation, inspection or maintenance. Therefore, it is **YOUR** responsibility to use safe work practices in these areas.

The information provided in this manual supplements the specific information about the machine that is contained in the manufacturer's manual(s). Other information that may affect the safe operation of the machine may be contained on safety signs or in insurance requirements, employer's safety and training programs, safety codes, local, state/provincial and federal laws, rules and regulations.



**Read And  
Understand  
Manuals Before  
Operating**

**IMPORTANT!** Before you operate the compact excavator, make sure you have the manufacturer's manual(s) for this machine and all attachments. If the manufacturer's manuals are missing, obtain replacement manuals from your employer, equipment dealer or directly from the manufacturer. Keep this safety manual and the manufacturer's manuals with the machine at all times. Read and understand all manuals.

Safety videos and other training resources are available from some manufacturers. Operators are encouraged to periodically review the safety video.

3

## Safety Alerts

### Symbol

This Safety Alert Symbol means: "**ATTENTION! STAY ALERT! YOUR SAFETY IS INVOLVED!**"



The Safety Alert Symbol identifies important safety messages on equipment, safety signs, in manuals or elsewhere. When you see this symbol, be alert to the possibility of death or personal injury. Carefully read the message that follows and inform other operators. Follow instructions in the safety message.

### Signal Words

Signal words are distinctive words that will typically be found on safety signs on the compact excavator and other worksite equipment. These words may also be found in this manual and the manufacturer's manuals. These words are intended to alert the operator to a hazard and the degree of severity of the hazard.



**DANGER** indicates a hazardous situation which, if not avoided, will result in death or serious injury.



**WARNING** indicates a hazardous situation which, if not avoided, could result in death or serious injury.



**CAUTION** indicates a hazardous situation which, if not avoided, could result in minor or moderate injury.



**NOTICE** indicates a property damage message.

# One-Call First



**Call Before You Dig  
Dial 811 (USA only)**



**888-258-0808  
(USA and Canada)**

## Call

Before starting any digging project, contact the local One-Call service by dialing 811 (USA only) to have underground utilities located. A One-Call referral number, **1-888-258-0808**, is also available for both USA and Canada.

One-Call will notify participating utility companies that you intend to dig. You must also call utility companies that do not participate in the One-Call service.

Always inspect the jobsite for evidence of unmarked utilities and contact others if necessary.

## Plan The Work

Be aware of the lead time for marking the work area. This time may vary from state to state and county to county. If you do not locate utilities, you may have an accident or suffer injuries, cause service interruptions, damage the environment or experience job delays.

## Dig

Most utilities mark their underground facilities using American Public Works Association (APWA) underground color codes. Verify marks before digging.

In the United States, OSHA Standard 29 CFR 1926.651 requires that the estimated location of underground utilities be determined before beginning an excavation. When actual excavation approaches an estimated utility location, the exact location of the underground installation must be determined by a safe, acceptable and dependable method. Other OSHA regulations may also apply to the jobsite.

5

# A Word To The User/Operator

It is **YOUR** responsibility to read and understand the safety manual and the manufacturer's manuals before operating this machine. This safety manual takes you step by step through the working day.

Graphics have been provided to help you understand the text.

**IMPORTANT: This manual covers safe practices for Compact Excavators.** If the machine is equipped with special attachments, read the manufacturer's operator and safety manuals pertaining to those attachments before using them.

Remember that **YOU** are the key to safety. Good safety practices not only protect you but also protect the people around you. Study this manual and the manufacturer's manuals for the specific machine. Make them a working part of your safety program. Keep in mind that this safety manual is written only for compact excavators.

Contact the manufacturer of the equipment to answer any questions about safe operation that remain after studying the manufacturer's manual(s) and this safety manual.



**Practice all other usual and customary safe working precautions and remember:**

**SAFE OPERATION IS UP TO YOU!**

**YOU CAN PREVENT DEATH OR SERIOUS INJURY CAUSED BY UNSAFE WORK PRACTICES!**

# Follow A Safety Program

## Be Alert!

Know where to get assistance. Know where to find and how to use a first aid kit and fire extinguisher/fire suppression system.

## Be Aware!

Take advantage of training programs offered.

## Be Careful!

Human error is caused by many factors: carelessness, fatigue, overload, preoccupation, unfamiliarity of the operator with the machine or attachment, drugs, and alcohol to name a few. You can prevent death or serious injury caused by unsafe work practices.

For your safety and the safety of others, encourage fellow workers to act safely.



Never Operate While Impaired By Alcohol Or Drugs

## For Safe Operation

You must be a qualified and authorized operator for safe operation of this machine. You must clearly understand the written instructions supplied by the manufacturer, be trained—including actual operation of the compact excavator—and know the safety rules and regulations for the worksite. It is a good safety practice to point out and explain safety signs and practices and ensure others understand the importance of following these instructions.

**WARNING!** Drugs and alcohol affect an operator's alertness and coordination and the operator's ability to safely operate the equipment. **Never operate the compact excavator while impaired by use of alcohol or drugs. Never knowingly allow the operation of this machine when operator alertness or coordination is impaired.** An operator taking prescription or over-the-counter medication must consult a medical professional regarding any side effects of the medication that would hinder the ability to safely operate this equipment.

# Follow A Safety Program

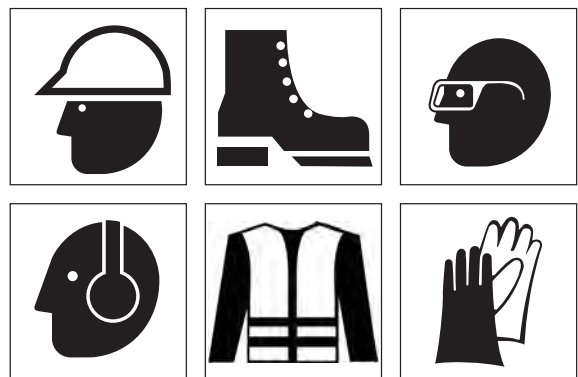
## Protect Yourself

Wear personal protective clothing and Personal Protective Equipment (PPE) issued to you or called for by job conditions.

You may need:

- Hard hat
- Safety boots with non-slip soles
- Safety glasses, goggles or face shield
- Heavy-duty gloves
- Hearing protection
- Reflective or high-visibility clothing
- Wet weather gear
- Respirator or filter mask

Wear whatever is needed to protect yourself—do not take chances.



**WARNING!** Prevent death or serious injury from entanglement. **Do not wear loose clothing or accessories. Restrain long hair. Stay away from all rotating components when the engine is running.** Contact, wrapping or entanglement with rotating or moving parts could result in death or serious injury.



Avoid Entanglement

# Follow A Safety Program

## Know The Rules

Most employers have rules governing operation and maintenance of equipment. Before you start work at a new location, check with your supervisor or the safety coordinator. Ask about the rules you will be expected to obey.

The Occupational Safety and Health Administration (OSHA) enforces federal laws within the United States that apply to the safe operation, application and maintenance of equipment on a worksite. It is the employer's responsibility to comply with these laws. A federal representative may periodically inspect a worksite to see that these laws are being followed.

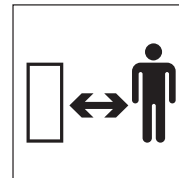
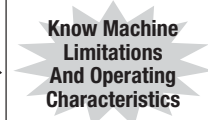
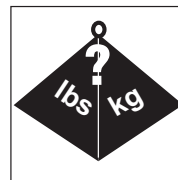
There may also be local, state/provincial, federal laws or international regulations that apply to this equipment and its use, along with specific worksite or employer rules. It is important that you know and comply with all applicable laws and rules, including those requiring operator training and certification.



# Follow A Safety Program

## Some Rules You Must Work By

- Know the limitations and operating characteristics of the compact excavator. Do not overload it.
- Always wear the seat belt, if equipped. If the compact excavator is equipped with a foldable TOPS/ROPS, do not fasten the seat belt when the TOPS/ROPS is in the down position.
- Always have all shields and guards properly installed before operating the machine.
- Inspect the machine and all attachments before each use as specified by the manufacturer and your employer. Ensure the attachment is properly installed. (See page 17, **Quick-coupling Device Safety**.)
- Only use parts and attachments that are approved by the original equipment manufacturer.
- Never modify or remove any part of the equipment (except for service—then make sure it is replaced).
- Read and understand all safety signs installed on the machine.
- Know the location of other personnel and machines and make sure they are a safe distance from the machine.
- Know the worksite. Be aware of possible hazards that you may encounter.



# Follow A Safety Program

- Always look in the direction of machine or boom movement. Drive facing the travel direction whenever possible.
- Make sure you understand the rules covering traffic at the worksite. Know what all signs, flags and markings mean.
- Understand hand, flag, horn, whistle, siren and bell signals, if used at the worksite.
- Know when to use lights, turn signals, flashers and horns, if equipped.
- Do not allow riders.
- Keep hands and feet on controls when operating.
- Never lift or swing a load or attachment over anyone.
- Whenever you leave the machine, lower the excavator blade, bucket or other attachments to the ground. Stop the engine. Cycle the hydraulic controls, including auxiliary hydraulic control, to relieve trapped pressure. Engage control lock if equipped, and remove the ignition key. (See page 39, **Machine Shutdown.**)
- When transporting the compact excavator on a trailer, follow the manufacturer's instructions for loading, tying down and unloading the compact excavator.



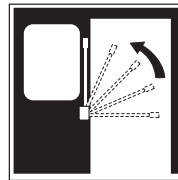
**Understand  
Worksite Signals**



**No Riders**



**Never Lift Or  
Swing A Load Or  
Attachment  
Over Anyone**



**Engage  
Control Lock**

# Follow A Safety Program

## Know The Equipment

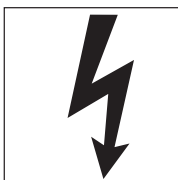
Read and understand the DANGER, WARNING, CAUTION and NOTICE safety signs and other informational signs found on the compact excavator and in the manufacturer's operator manual. Ask your supervisor to explain any information you do not understand. Failure to obey safety instructions could result in death or serious injury.

Make sure all the manufacturer's protective structures, guards, shields, screens and panels are in good repair, in place and securely fastened. Damaged, missing or

weakened safety components can create a hazardous situation for you as the operator. **Never** remove or modify any safety components on the compact excavator. The excavator can be operated temporarily with a foldable TOPS/ROPS lowered for access through height-restricted openings. Do not fasten the seat belt when the TOPS/ROPS is in the down position.

Know the following about this compact excavator and all attachments.

- Function, purpose and use of controls
- The functions of all gauges, lights, dials, switches
- Slope and uneven terrain capabilities and proper operation – never operate on a slope with a foldable TOPS/ROPS in the down position.
- Braking and steering characteristics
- Turning radius and clearances
- How to quickly stop equipment in an emergency



**Read And  
Understand All  
Safety Signs**



**Read And  
Understand  
Manuals Before  
Operating**

# Prepare For Safe Operation

## Check And Use All Available Protective And Safety Devices

Keep all protective devices in place and tightly fastened. Make certain all guards, screens and panels, manufacturer's operator manuals, and safety signs are installed on the machine and legible as supplied by the manufacturer. See that each item is securely in place and in operating condition.

The machine may be equipped with:

- A seat belt or other type of restraint
- Control locking device
- Safety signs
- Access and egress system (i.e., grab handles, handrails) and protective covers
- Travel alarm and back-up alarm
- Falling object guard structure (FOGS), falling object protective structure (FOPS), roll-over protective structure (ROPS)/tip-over protective structure (TOPS)
- Guards
- Special enclosures or accessories required for task or worksite conditions
- Operator protective structure (OPS) – side, front and rear shields, screens and doors

- Warning lights and devices
- Alternate exits
- Mirrors
- Fire extinguisher
- First aid kit
- Windshield wipers and washers
- Window defroster
- Operating lights
- Horn

Know which devices are required for protection during your specific operation and use them. The excavator can be operated temporarily with the TOPS/ROPS lowered for access through height restricted openings. Do not fasten the seat belt when the TOPS/ROPS is in the down position.

**WARNING! NEVER remove or modify safety equipment.** Operating a machine without a protective structure (TOPS/ROPS, FOGS/FOPS or OPS) could result in death or serious injury. (See page 44, **Protective Structure Safety**.)

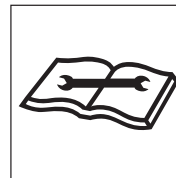


# Prepare For Safe Operation

## Check The Machine

Before you begin the workday, inspect the machine and have all systems in good operational condition. Do not operate the machine until all problems are corrected.

- Perform daily and periodic service procedures as instructed by the equipment manufacturer.
- Check that no safety switches or interlocks have been bypassed and that no warning tags have been placed on the machine.
- Check that safety signs, special instructions, lift capacity charts and operator manuals are legible and in the proper location.
- Check condition and operation of the seat belt and its mounts, if equipped.
- Make sure that the foldable TOPS/ROPS, if equipped, is properly secured in the raised position.
- Check condition and operation of the attachment quick-coupling device, if equipped. Perform daily cleaning and maintenance following the manufacturer's instructions. (See page 17, **Quick-coupling Device Safety**.)
- Inspect steps, guardrails, platforms and handholds for damage or loose parts.



# Prepare For Safe Operation

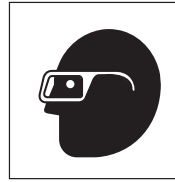
- Check the fuel and hydraulic systems. Have leaks repaired and fill to proper level.
- Check all exposed hydraulic components for leaks, routing problems or damage. Report worn or damaged components.

**WARNING!** Diesel fuel and hydraulic fluid under pressure can penetrate the skin or eyes and cause serious injury, blindness or death. Fluid leaks under pressure may not be visible. **Use a piece of cardboard or wood to find leaks, not your hand. Wear a face shield or safety goggles for eye protection.** If fluid is injected into the skin, it must be removed within a few hours by medical personnel familiar with this type of injury. (See page 46, **Hydraulic System Hazards.**)

- Check the cooling system.

**WARNING!** Prevent possible injury from explosive release of hot fluids. **Allow the radiator to cool before checking the fluid level.** (See page 45, **Cooling System Hazards.**)

- Keep radiators and coolers clean and free of oil, grease, dirt, debris and moisture.
- Make sure all doors, guards and covers are in place and secured properly.



**Wear  
Eye Protection**



**High Pressure  
Fluid Can Inject  
Into The Body**



**Do Not  
Loosen Cap  
Until Cool**



**Check  
The Radiator  
And Engine**

15

# Prepare For Safe Operation

## Check The Machine (continued)

- Check the tracks for broken or damaged pins, bushings, and other parts.
- Check the tracks for proper tension adjustment according to manufacturer's instructions.
- Check the tracks for damage or wear. Replace badly worn or damaged tracks.
- Check the slew/swing brake for proper operation.
- Inspect working and other lights for proper operation.
- Inspect boom, arm and attachment for wear and damage.
- Make sure fire extinguishers are fully charged and in good working order.

## Check Attachment And Coupler Installation

When changing buckets or installing attachments, follow the manufacturer's instructions for proper maintenance and coupling. Make sure all connectors are securely fastened. Tighten all bolts, nuts and screws to torques recommended.

Check the attachment coupler and the attachment for wear and hydraulic leaks before coupling the attachment.

Before operating, ensure that quick-coupler pins or wedges are fully engaged and visibly locked to the attachment.

**WARNING!** Avoid possible crushing injury. **Failure to properly secure the attachment to the machine coupler can allow the attachment to come off and could result in death or serious injury.** (See page 17, **Quick-coupling Device Safety.**)

# Prepare For Safe Operation

## Quick-coupling Device Safety

Before using a quick-coupling device you must know and understand proper installation, maintenance and operation.

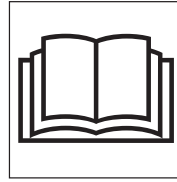
**WARNING! Failure to read and follow manufacturer's instructions for the correct operation and maintenance of the quick-coupler can allow the attachment to come off and cause death or serious injury.**

Protect yourself from injury:

- Install and maintain equipment, attachments and their operating systems according to manufacturers' instructions.
- Securely latch attachments before work begins.
- Follow the manufacturer's instructions for using positive locks on quick-coupling equipment.
- Make frequent visual inspections of quick-coupling systems—especially after changing attachments.
- Always check for interference limits of the coupler or tool with the carrier before operating.

Do not operate the machine if:

- there exists an incompatibility among components.
- there are broken, damaged or badly worn components.
- the lock/secure feature of the quick-coupler is impaired.
- the engaging lever or device is not fully engaged in a lock/secure condition.



**Read And Understand Manuals Before Operating**

**WARNING!** A quick-coupler that is not properly locked/secured could result in death or serious injury. **Perform all steps to lock/secure the device.** The steps to confirm that the device is properly locked/secured may include any or all of the following:

- Manually installing a locking pin, actuating a lever or other device.
- Movement of the attached work tool to confirm its engaged lock/secure condition.
- A visual check of the components as instructed by the quick-coupler manufacturer.

**WARNING!** A quick-coupler that is disengaged when the attachment is in an unstable position could result in death or serious injury. **Place the attachment in a stable position, as instructed by the manufacturer, whenever coupling or uncoupling the attachment.**

17

# Prepare For Safe Operation

## Clean Up

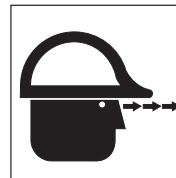
Clean windshields, mirrors and all lights. Use water and a clean cloth. Know and follow the manufacturer's recommendations for using cleaning agents other than clean water on polycarbonate glazing.

Clean out the operator's area. Steps and handholds must be clean and functional. Oil, grass, leaves, needles, snow, ice or mud in these areas can cause you to slip and fall.

Clean your boots before getting on the machine.

Clean out trash and debris buildup promptly, especially in the engine compartment, the battery box, around exhaust components, under the machine and around rotating components.

Remove all loose personal items or other objects from the operator's compartment. Secure these items in a fixed tool box or remove them from the machine. Do not store any flammable material such as ether/cold-start fluid or oily rags in the operator's compartment.



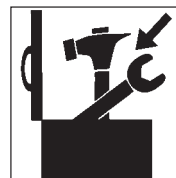
**Maintain Vision – Clean Up**



**Avoid Falls – Clean Slippery Surfaces**



**Avoid Fire – Clean Out Debris**



**Put Away Tools And Loose Items**

# Prepare For Safe Operation

## Check The Work Area

Know—beforehand—as much about the worksite as possible. Locate all ground workers near the worksite and make sure clothing worn is easily seen. Be aware of weather conditions that can affect visibility, ground stability and traction.

Check for:

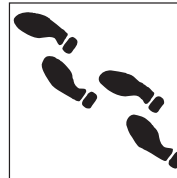
- Location of steep slopes, slide areas, drop-offs and overhangs
- Adequate traction on slopes
- Traffic locations and movement
- Thick dust, smoke and fog
- Soil conditions—look for signs of instability such as cracks or settlement
- Standing water and marshy areas
- Rocks and stumps
- Holes, obstructions, mud or ice
- Location of open trenches
- Exact location of any buried and/or overhead electrical, gas, telephone, water, sewer or other utility lines

Have the utility company mark, shut off or relocate the utility before you begin working.

Know the location and work plan for other machines on the worksite.

Correct unsafe conditions. Avoid operating in problem areas that cannot be corrected.

When operating the machine inside a building, know what clearances you will encounter—overhead, doorway, aisles, etc. Also, know the weight limitations of floors and ramps. Make sure there is sufficient ventilation for inside operation.



Walk Around  
The Worksite



Be Seen –  
Wear Visible  
Clothing

19

# Prepare For Safe Operation

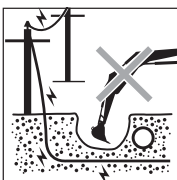
## Check The Work Area (continued)

Know the exact location of electrical, telephone, gas or other utility lines. (See page 5, **One-Call First.**)

**DANGER!** Death or serious injury will result from touching or being near a machine that is in contact with or near an energized electrical source. **Never approach power lines with any part of the machine or load unless all local, state/provincial and federal (OSHA) required safety precautions have been taken.** Use extreme caution because high voltage sources can arc without contact.

When working near power lines, you must assume all lines are energized.

Maintain a safe distance from all utilities.  
(See page 31, **Utilities—Overhead And Underground.**)



Locate All  
Utilities, Maintain  
A Safe Distance

## Use Caution When Fueling

**IMPORTANT!** Always use approved fuel containers and dispensing equipment.

Fuels are flammable, so observe these practices to reduce the possibility of a serious accident.

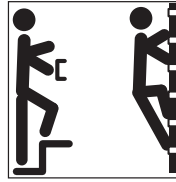
- Shut off engine and ignition during refueling.
- Always ground the fuel nozzle against the filler neck to avoid sparks.
- Keep sparks and open flames away from fuel.
- Do not use a cell phone or two-way radio while fueling or handling fuel—they could cause sparks.
- Do not smoke while refueling or when handling fuel containers.
- Do not overfill the tank or spill fuel. Clean up spilled fuel immediately.

# Prepare For Safe Operation

## Mount And Dismount Properly

When you enter or leave the machine:

- Maintain a three-point contact with the machine. Three-point contact is defined as maintaining contact with at least one hand and two feet, or two hands and one foot, at all times.
- Face the machine when either mounting or dismounting.
- Use handholds, handrails, ladders or steps (as provided).
- The upperstructure and undercarriage must be oriented to align the access system.
- Never use control levers as handholds.
- Never step on foot controls when entering or leaving.
- Clean your boots and wipe your hands before mounting or dismounting.
- Never jump on or off the machine.
- Never attempt to mount or dismount a moving machine.
- Never mount or dismount while carrying tools or objects that prevent three-point contact.



Maintain  
Three-Point Contact –  
Face Machine



Do Not Jump Off  
Machine



Do Not  
Use Controls As  
Handholds

21

# Start Safely

## Look Out For Others

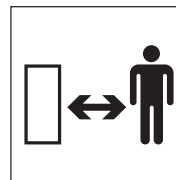
Before starting, walk completely around the machine operating area. Make sure no one is under it, on it or close to it. Do not start the engine until everyone is clear of the operating area.



Walk-  
Around  
Inspection

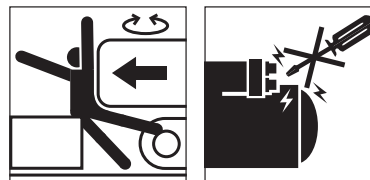
## Starting The Engine

Do not start the engine or move any of the controls if there is a “DO NOT OPERATE” or similar warning tag attached to the start switch or controls. Check with your supervisor.



Keep  
Bystanders  
Away

**WARNING! Start the engine only from the operator's seat. Never attempt to start the engine by shorting across starter terminals or reaching for the key from outside the cab.** This could result in the machine moving suddenly and unexpectedly and cause death or serious injury.



Start Only  
From Operator's  
Position

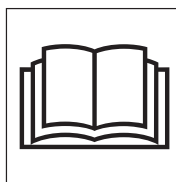
# Start Safely

Know the exact starting procedures for this machine. See the manufacturer's manual(s) for starting procedures.

- Clear the area of all persons.
- Sit in the operator's seat and adjust the seat so you can operate all the controls properly.
- Familiarize yourself with warning devices, gauges and operating controls.
- Close or secure the cab door, if equipped.
- Fasten the seat belt, if equipped. If the compact excavator is equipped with a foldable TOPS/ROPS, do not fasten the seat belt when the TOPS/ROPS is in the down position.
- Put all controls, including those for auxiliary equipment, in the neutral/park position.
- Activate controls by releasing the control lock, if equipped.
- Start the engine following the instructions in the manufacturer's manual(s).

If it is necessary to run the engine or operate the machine within an enclosed area, be sure there is adequate ventilation.

**WARNING! Never operate any type of engine without proper ventilation—exhaust fumes can kill.**



**Know Starting Procedure, Read Manual**



**Fasten Seat Belt, Use TOPS/ROPS**



**Ventilate Work Area**

23

# Start Safely

## Starting Aids

**Do not** use ether/cold-start fluid if the engine is equipped with glow plugs or intake manifold preheater.

Ether/cold-start fluid is HIGHLY FLAMMABLE. Before using it, always read the instructions on the ether/cold-start fluid container and the instructions in the manufacturer's manual(s). **Do not** carry loose cans of starting fluid on the machine while operating.

If booster cables are used, follow the instructions in the manufacturer's manual(s). The operator must be in the operator's seat when boost-starting the engine so that the machine will be under control when the engine starts. Boost-starting is a two-person operation. A battery explosion or a run-away machine could result from improper starting procedures.

Never boost-start a frozen battery. (See page 48, **Avoid Battery Explosion.**)

## After Starting The Engine

Observe gauges, instruments, and warning lights to ensure that they are functioning and their readings are within the operating range.

With the control levers or joysticks in neutral, test engine speed control.

## Run An Operating Check

Do not use a machine that is not in proper operating condition. It is the **operator's responsibility** to check the condition of all systems, and to run the check in a safe area.

**WARNING! Do not allow anyone to stand within the operating work radius of the machine and load.** Contact with moving parts of the compact excavator or load can cause death or serious injury.



**Keep Bystanders Away**

# Start Safely

## Test All Controls

Follow the manufacturer's recommended warm-up procedures and bring all machine systems to operating temperature.

Machines come equipped with various control configurations, patterns and operating modes. Some have selectable or configurable controls that allow operation to suit personal preferences or specific applications. Make sure that you know which control pattern has been selected and understand how the machine will operate.

Make sure the engine is operating correctly. Operate each machine control to check all functions.

Check for possible interference between the attachment and the cab and operate appropriately.

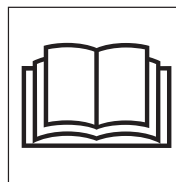
Make sure the attachment quick-coupling device (if equipped) is operating properly, fully engaged and visibly locked. (See page 17, **Quick-coupling Device Safety**.)

Check the blade location before traveling. When the blade is in the rear, operate the steering levers in the opposite direction as when the blade is in the front. See the machine manufacturer's manual.

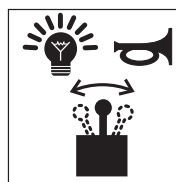
Operate the control(s) to ensure correct operation in forward, neutral and reverse.

Test steering—right and left—while moving slowly.

**WARNING!** Prevent possible injury from loss of control. **Know and understand the selected control pattern and operating mode before operating. Be certain you can control speed, direction, braking and boom motion before operating the machine.**



**Read And Understand Manuals Before Operating**



**Check Instruments And Controls**

25

# Operate Safely

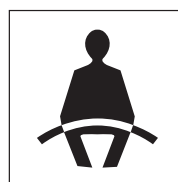
## Remember

- Stay in the operator's seat, with the seat belt fastened, if equipped. If the compact excavator is equipped with a foldable TOPS/ROPS, do not fasten the seat belt when the TOPS/ROPS is in the down position.
- Understand the machine's limitations. Be in control of the machine at all times.
- Assure yourself that the work area is clear of all bystanders and other machines. Stop the machine immediately if anyone approaches.
- If a failure that causes loss of control occurs, stop all machine motion as quickly as possible. Shut the machine down and remove the key. Correct or report the problem immediately.

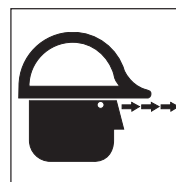
## Remember The Other Person

**WARNING!** Never allow an untrained or unqualified person to operate this machine. Handled improperly, this machine could cause death or serious injury.

Do not allow anyone within the operating work radius of the compact excavator.



**Fasten Seat Belt, Use TOPS/ROPS**



**Look Before Moving The Machine Or Boom**

Never use a bucket or other attachment as a work platform or personnel carrier.

**WARNING!** Prevent possible injury from fall or rollover. The compact excavator is a one-person machine. **NEVER PERMIT RIDERS.**

Always look around before you travel or move the boom. Look in the direction of machine movement.

Awareness on your part can prevent accidents.

# Operate Safely

## Traveling On The Worksite

Know and understand the worksite traffic flow patterns and obey signalmen, road signs and flagmen.

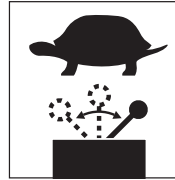
Check blade location before traveling. When blade is positioned to the rear, operate the steering levers in the opposite direction as when the blade is in the front.

The retractable track frame, if equipped, should be extended for traveling on the worksite. The track frame can be retracted to access narrow areas. Read and know manufacturer's instructions before operation.

Know the maximum height and width of the machine. Do not obstruct your vision when traveling. Always look in the direction of travel. Drive facing the travel direction when possible.

Operate the controls smoothly and slowly. Rapid and jerky movement of the controls can cause loss of both machine stability and control of the load.

When moving the machine, watch that enough clearance is available on both sides and above the boom and cab. Be especially careful to allow extra clearance on uneven ground.



Operate Controls Smoothly And Slowly



Know Weight Limits

Check for hazards or obstructions before entering an underpass or other area with restricted clearance. Check height and side clearances.

**WARNING!** Avoid possible injury. The weight of the machine may cause the ground, dock, ramp or floor to give way, causing loss of control, fall or tipover. **Know weight limits and stay clear of the edges of excavations and drop-offs.** Failure to know and observe weight limits and use caution could result in death or serious injury.

27

# Operate Safely

## Traveling On The Worksite (continued)

Make sure all surfaces will support the weight of the machine.

Do not cross ditches, creeks or wet draws without an adequate fill or bridge crossing.

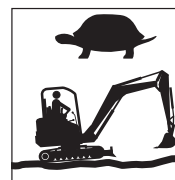
Match travel speed to the traffic, weather and ground conditions. Take it slow and easy when traveling. Travel cautiously over rough or slippery ground and on slopes. Reduce speed when travelling over a rise.

Always give the right of way to loaded machines. Maintain a safe distance from other machines.

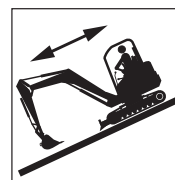
If you encounter a blind corner, stop and then proceed with caution.

Avoid traveling over obstacles (logs, tree stumps, rough terrain, ditches, curbs, railroad tracks) whenever possible. If you must cross an obstacle, do so slowly and with caution.

Avoid steep slopes or unstable surfaces. If it is necessary to travel on a slope, follow manufacturer's specific instructions. When on a slope, keep the boom centered and attachment as low and as close to the



Travel Slowly Over Rough, Hazardous Terrain



Drive Straight Up And Down – NOT ACROSS – Steep Slopes

machine as possible. Proceed with extreme caution. Do not drive **ACROSS** a steep slope under any circumstances. Drive straight up and down a slope.

Avoid turning on a slope. If it is necessary, use extreme caution and make the turn **WIDE and SLOW** with the boom centered and attachment as low and as close to the machine as possible.

Avoid sudden movement of the travel controls.

# Operate Safely

## Safety Precautions

Never reach into the compact excavator and attempt to operate the controls from outside the cab.

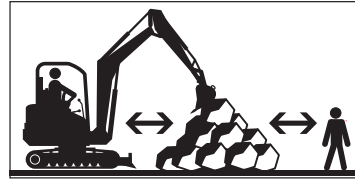
Before starting to excavate, set up safety barriers to the sides and rear area of the swing pattern to prevent anyone from walking into the working area.

Read and know manufacturer's instructions before operation.

Make sure you are aware of personnel or machines that may be hidden in blind spots on the worksite, such as piles or stacks of material.

Make sure the machine has sufficient clearance from other machines or material on the worksite to prevent contact during machine or attachment movement.

**WARNING!** Prevent death or serious injury. **Never lift, move or swing a load over any person or any machine cab.**



Check Clearance,  
Look Out For  
Others



Do Not Lift  
Or Swing A Load  
Or Attachment  
Over Anyone

Know and use the hand signals required for particular jobs. Know who has the responsibility for signaling. Take signals from one person only.

Do not operate during storms with high winds or lightning strikes. Do not mount or dismount during a period of lightning strikes. If you are on the machine, stay on it. Warn others to stay clear of the machine in case of a lightning strike.

29

# Operate Safely

## Load Lifting

Consult the rated lift capacity chart. Do not overload this machine. Know the exact lifting capacity of the machine as equipped. Make sure you have and know how to use a current lift capacity chart for the machine. Changing conditions such as slopes, wind, ice, mud, soft ground, type of load or the weight of attachments will affect the capacity and operating characteristics of the machine.

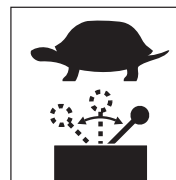
Consult your lift chart. Lifting and handling loads over the end of the machine, rather than over either side, will improve the lifting performance of the machine.

The retractable track frame, if equipped, should be fully extended for increased lifting performance.

Attach loads only to the manufacturer's designated lifting points, if equipped.

If equipped, keep blade lowered for increased lifting performance. If ground is soft, place pads or timbers under the blade.

Operate the controls smoothly and slowly. Rapid and jerky movement of the controls can cause loss of both machine stability and control of the load.



Operate  
Controls Smoothly  
And Slowly

When lifting, be sure the load is properly balanced. Move slowly so the load does not sway or swing around. Use a tag line for control.

If tracks or blade leave the ground, slowly lower the load to return the machine to the ground. Do not drop the load suddenly, because this can lead to loss of control.

Do not exceed rated lift capacity. Excessive load can cause tipping or loss of control.

Carry the load/attachment low and as close to the machine as possible. You must allow for movement in all directions. Be careful to maintain clearance of the attachment and load from the cab.

Keep all guards in place and windows closed or locked open. Keep cab doors closed or otherwise secured, if equipped.

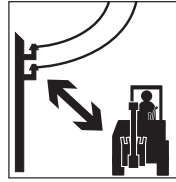
Never leave the operator's seat with a load suspended. (See page 39, **Machine Shutdown**.)

# Operate Safely

## Utilities – Overhead And Underground

**DANGER!** Electrocutation or serious injury will result from **CONTACTING** or **APPROACHING** power lines or apparatus. **Maintain Minimum Approach Distance.** (See chart.)

**DANGER!** Death or serious injury will result from touching or being near a machine that is in contact with or near an energized electrical source. **Never approach power lines with any part of the machine or load unless all local, state/provincial and federal (OSHA) required safety precautions have been taken.** Use extreme caution because high voltage sources can arc without contact.



**Maintain Minimum Approach Distance**



**Stay Clear Of Energized Equipment**

REQUIRED CLEARANCE FOR OPERATION NEAR HIGH VOLTAGE POWER LINES		
Normal Voltage, kV (Phase to Phase)	Minimum Approach Distance [Note (1)]	
	ft	(m)
to 50	10	(3.0)
Over 50 to 200	15	(4.6)
Over 200 to 350	20	(6.1)
Over 350 to 500	25	(7.6)
Over 500 to 750	35	(10.7)
Over 750 to 1,000	45	(13.7)

NOTE: (1) Environmental conditions such as fog, smoke or precipitation may require increased clearances.

Check overhead clearances. If possible, have power to the lines de-energized and visibly grounded. If not possible, request a signal person for guidance to maintain at least the Minimum Approach Distance. (See chart.)

If the machine or load contacts an energized line, stay in the machine and attempt to break contact. Warn others to stay away from the machine. If machine catches fire and you are forced to leave, jump clear of the machine with both feet together and hop or shuffle away. **DO NOT** touch machine and ground at the same time.

# Operate Safely

## Locate All Underground Utilities

Confirm that One-Call has been contacted. Confirm that any utilities not subscribing to One-Call have been contacted. Confirm that the site has been marked or cleared. (See page 5, **One-Call First.**)

Obtain all information pertaining to the locate request, including the One-Call confirmation code or ticket number. If the facility owner has provided a locate sketch, obtain a copy. Review any engineering drawings provided by utilities. This information should be retained.

Personally verify One-Call utility marks. There are variations from state to state.

Take a copy of the locate sketch to the job site. Confirm all of the locates. Review the site for signs of unmarked utilities. These signs may include pedestals, pole risers, meters, trench lines, manhole covers, sewer drain outlets, etc. Review not only the immediate area, but also the perimeter of the area for utility markers.

Additionally, the area should be swept by an experienced operator using a device to locate utilities and large metal objects.

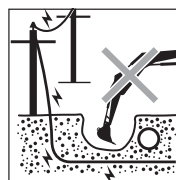
Any inconsistencies with line locations or any inaccurate locates must be resolved.

When excavating near underground services, expose the service by hand-digging or by using soft excavation, such as vacuum excavation, if permitted by local utilities.

When gas lines are present on the site, do not smoke or do anything to cause a spark in the vicinity of a gas line.

Make plans to restrict working area access—with cones and tape, barriers, warning signs, fences, etc.—until the job is complete.

Make certain that you are in compliance with all local, state/provincial, national and other requirements and regulations, including those regarding open excavations, or “potholes.”



**Locate All Utilities, Maintain A Safe Distance**

# Operate Safely

## Trenching Safety Precautions

Follow the worksite plan for proper construction of the trench. Check with your supervisor if you are unsure of correct trench construction or if operating conditions change.

Stay alert to changes in soil conditions. Trench collapse is hazardous to all workers in the area and could cause the machine to slide into the trench.

Keep heavy loads and equipment as far from the trench as possible.

Keep spoil and stored materials such as pipe at least two feet from the edge of the trench.

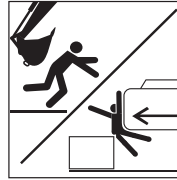
Keep personnel away from the equipment and attachments.

Never swing a load or attachment over anyone.

Do not undercut the machine.

**WARNING! Do not dig under the machine or blade.** A resulting cave-in could cause death or serious injury.

**WARNING! Avoid possible death or serious injury from trench wall collapse. Before backfilling, see the manufacturer's manual for any specific instructions. Do not get too close to the edge of the cut.** The weight of the machine plus the fill could cause the trench wall to collapse.



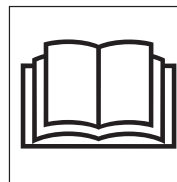
Keep Personnel Away From Equipment And Attachments

# Operate Safely

## Slope And Uneven Terrain Operation

Compact excavator stability and load capacity are greatly reduced on slopes. Ensure the operation can be done safely. Prevent overturns and maintain stability control:

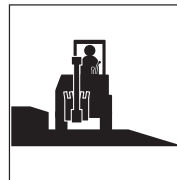
- Use machines equipped with TOPS/ROPS and a seat belt. Make sure folding TOPS/ROPS is raised and locked in place—always use the seat belt.
- The retractable track frame, if equipped, should be extended for operating on slopes or uneven terrain. Read and know manufacturer's instructions before operation.
- Review the manufacturer's manual for specific instructions and limitations, including those for proper operation of alternate/emergency exits.
- Avoid extremely steep slope operation.
- Keep machine movements slow and smooth.
- Level the working area and machine as much as possible.
- Avoid working with the tracks across a slope. This will reduce stability and increase the tendency of the machine to slide. Position the machine with the tracks running up and down the slope—blade downhill and lowered.
- Avoid slippery ground conditions.



Always Check Manuals For Specific Instructions



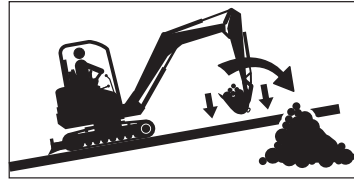
Fasten Seat Belt, Use TOPS/ROPS



Level The Work Area If Possible

# Operate Safely

- Travel straight up and down the slope with the attachment low and close to the machine. Do not move the boom while travelling.
- Avoid swinging to the downhill side of a slope. Always keep the boom and attachment as low and close to the machine as possible.



Swing Load Uphill When On A Slope

If the machine begins to tip, roll or slide, stay in the machine with the seat belt securely fastened. Lower the attachment immediately. Hold on firmly and brace your feet on the floor. Lean away from the point of impact.

When operating the compact excavator on a slope, swing to the uphill side to dump load, if possible. If downhill dumping is necessary, swing only as far as required to dump the bucket. Use extreme caution. Always drop spoil a sufficient distance from a trench to prevent cave-ins.

If possible, avoid working with the tracks across a slope.

Before moving the machine, raise the blade sufficiently to clear the ground, and then drive the machine forward or backward as required. Lower the blade to level the machine.

35

# Operate Safely

## Hazardous Conditions

When working in hazardous areas, be extremely alert.

Always consult the manufacturer's operator manual for specific instructions.

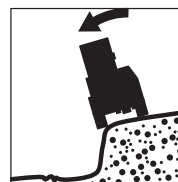
Extreme caution is required when working near the edge of an excavation. Keep the machine a safe distance away from the edge. Avoid undercutting.

**WARNING! Never undercut a high bank.** The edges could collapse or a slide could occur, resulting in death or serious injury.

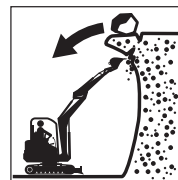
Work the jobsite in a manner that avoids creating overhangs or the need to be on top of banks or slopes. Never operate the machine close to the edge of an overhang or stockpile.

Extreme caution should be used when working along the top of banks and slopes. Keep as far back from the edge as possible. Level the area if possible. Keep the machine tracks perpendicular to the edge so that if part of the edge collapses, the machine can be moved back.

Immediately move the machine back at any indication the edge may be unstable.



Use Caution – Stay Safely Away From Bank Or Excavation Edge



Never Undercut A High Bank



Operate Perpendicular To Banks – Stay Back From The Edge

# Operate Safely

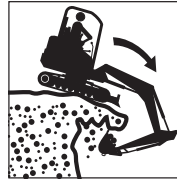
**WARNING! Do not dig under the machine.** A cave-in could result and the machine could fall into the excavation, resulting in death or serious injury.

## Avoid Silica Dust

Cutting or drilling concrete or rock containing quartz may result in exposure to silica dust. **Do not exceed Permissible Exposure Limits (PEL) to silica dust as determined by OSHA or other worksite rules and regulations.** Use a respirator, water spray or other means to control dust. Silica dust can cause lung disease and is known to cause cancer.

## Operation In Flammable/Explosive Atmosphere

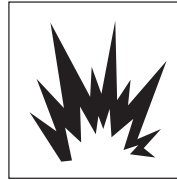
**WARNING!** Avoid possible death or serious injury. **Never operate an excavator in these areas. Use of these excavators in explosive atmospheres can result in fires and explosions, causing death or serious injury.**



**Use Caution Near  
Excavation Edge –  
Do Not Undercut  
Machine**



**Avoid  
Silica Dust**



**Do Not Operate In  
Explosive/Flammable  
Atmosphere**

37

# Operate Safely

## Towing

Many compact excavators may not be towed. Refer to the manufacturer's manual(s) for specific towing instructions.

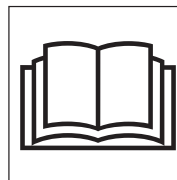
Never straddle a tow line or stand near a tow line under tension.

## Parking

Park the machine in a designated area out of traffic, preferably on level ground. (See page 39, **Machine Shutdown.**)

If freezing conditions are expected, the tracks should be first cleared of mud and dirt and the machine parked on planks or suitable debris.

Public roads are not suitable for parking. If the machine is disabled or you must park on a public road, barricade and mark the machine according to local and worksite regulations.



**Consult  
Manufacturer's  
Manual Before  
Towing**

# Shut Down Safely

## Machine Shutdown

Properly shutting down a compact excavator can help prevent accidents when the machine is left unattended. Shut down the excavator following the specific procedures in the manufacturer's operator manual.

A typical list includes:

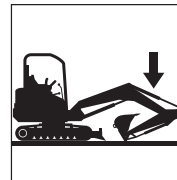
- Stop the machine.
- Make sure the area around the machine is clear of personnel.
- Slew the machine to align the upperstructure with the undercarriage, if possible.
- Return controls to neutral, including the auxiliary hydraulic controls.
- Lower the attachment and blade to the ground with slight down-pressure.
- Idle engine for a short cool-down period.
- Stop the engine.
- Cycle all hydraulic controls to relieve system pressure.
- Engage the control locking device, if equipped.
- Remove ignition key.
- Block the tracks if on a slope or incline.

- Check for and clean out trash build-up, especially in the engine compartment, battery box, around exhaust components, in confined spaces, under the machine and around rotating components.

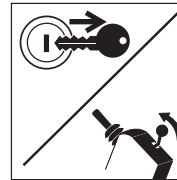
## Safe Dismounting

Never dismount from moving equipment. Observe proper shutdown practices before dismounting. Check for slippery steps and handholds.

Dismount carefully using three-point contact facing the machine. (See page 21, **Mount And Dismount Properly.**)



**Lower Attachment**



**Shut Off Engine, Remove Key, Engage Control Lock**

39

# Load And Unload The Machine Safely

## Loading And Unloading For Transport

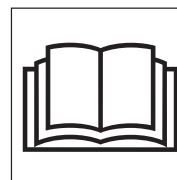
All machines are not loaded in the same way, and the procedures given in the manufacturer's manual(s) should always be followed.

Some precautions apply to all machines:

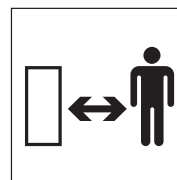
- Keep bystanders away.
- Wear the seat belt, if equipped.
- If the compact excavator is equipped with a foldable TOPS/ROPS, make sure it is properly secured in the raised position.
- Place transport vehicle on a firm, level surface.
- Block or support the rear of the trailer.
- Secure the parking brake and block transport vehicle so it cannot move.
- Use ramps with slip-resistant surfaces, adequate size and strength, low angle (15 degrees or less) and proper height.
- Keep trailer bed and ramps clear of mud, oil, ice, snow, leaves and other debris.
- Position the attachment to the front of the machine.
- Drive forward up the ramps, raising the blade high enough for clearance.
- Cover or remove any SMV (Slow-Moving Vehicle) emblem.

- Secure the cab door, attachment and accessories in the transport position.
- Engage upperstructure slew lock, if equipped.
- Chain and block the excavator securely for transport. Refer to the manufacturer's operator manual for tie-down procedures.

Measure the transport height and width of the loaded machine to avoid overhead and width obstructions. Make sure clearance flags, all lights and warning signs are in place and visible.



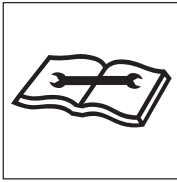
**Read Operator Manual**



**Keep Bystanders Away**

# Perform Maintenance Safely

## Maintain Equipment



Be sure to maintain equipment according to manufacturer's instructions. Regularly check the operation of the protective and safety devices.

**Do not** perform any work on the compact excavator unless you are authorized and qualified to do so.

If you have been authorized to maintain the equipment, **read the operator, maintenance and service manuals.** Study the instructions, check the lubrication charts and examine all the instruction messages on the machine. Maintenance can be dangerous unless performed properly. Be sure you have the necessary skill, information, tools and equipment to do the job correctly.

If adjustments must be made with the engine running, always work as a 2-person team with one person sitting in the operator's seat while the other works on the machine.

**IMPORTANT!** Do not modify equipment or add components not approved by the manufacturer. Use parts, lubricants and service techniques recommended by the manufacturer.

## Protect Yourself

Wear personal protective clothing and Personal Protective Equipment (PPE) issued to you or called for by job conditions.

You may need:

- Hard hat
- Safety boots with non-slip soles
- Safety glasses, goggles or face shield
- Apron and heavy-duty gloves
- Hearing protection
- Welding helmet or goggles
- Respirator or filter mask

Wear whatever is needed to protect yourself—do not take chances.

# Perform Maintenance Safely

**WARNING!** Prevent death or serious injury from entanglement. **Do not wear loose clothing or accessories. Restrain long hair. Stay away from all rotating components when the engine is running.**

Contact with or entanglement in rotating or moving parts could result in death or serious injury.

Wear a rubber apron and rubber gloves when working with corrosives. Wear gloves and safety shoes when handling wooden blocks, wire rope or sharp-edged metal.

Always use safety glasses, goggles or a face shield. They provide eye protection from fluids under pressure, during grinding and while servicing batteries. Protection is also needed from flying debris, liquids and loose material produced by equipment, tools and pressurized air/water/oil/fuel.

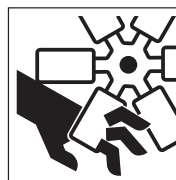
Wear a face shield when you disassemble spring-loaded components or work with battery acids. Wear a welding helmet or goggles with a shaded filter when you weld or cut with a torch.

Do not sand, grind, flame-cut, braze or weld without an approved respirator or appropriate ventilation. If welding

is required on the machine, refer to the manufacturer's manuals or consult the equipment dealer for proper procedures. Make sure all flammable material is cleared from the area.

Keep pockets free of all objects that could fall out and drop into machinery.

Handle tools and heavy parts sensibly, with regard for yourself and other persons. Lower items—do not drop them.



# Perform Maintenance Safely

## Prepare The Work Area

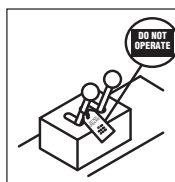
- Position the compact excavator in a level area out of the way of other working equipment.
- Make sure there is adequate light, ventilation and clearance.
- Remove oil, grease, ice and snow or water to eliminate any slippery surfaces.
- Clean around the machine and work area to minimize contamination. Clean up oil or fuel spills promptly and dispose of the material properly.

## Prepare The Machine

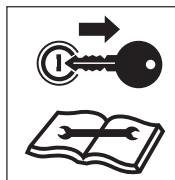
- Attach a “DO NOT OPERATE” warning tag to the control levers and remove the ignition key if the machine should not be started.
- Block the tracks.
- Release all hydraulic, water and air pressure. Lower, lock or block all hydraulically supported components.

**WARNING!** Disconnecting or loosening any hydraulic component or a part failure can cause unsupported equipment to drop. **Do not go under or near raised equipment unless supported by a manufacturer-approved support device(s).** Death or serious injury could result from falling equipment.

- Remove only guards or covers that provide access to the area being serviced. Replace all guards and covers when work is complete.



Use  
Warning Tags



Remove  
Key And Read  
Maintenance  
Manual



Use  
Approved  
Support Device

43

# Perform Maintenance Safely

## Use Approved Ventilation

If it is necessary to run an engine in an enclosed area, remove the exhaust fumes from the area with an exhaust pipe extension.

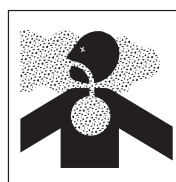
**WARNING!** Prevent possible injury. **Never work on machinery with the engine running unless instructed by the manufacturer's manuals for specific service.**

**WARNING!** **Never operate any type of engine without approved ventilation—EXHAUST FUMES CAN KILL.**

## Use Jacks And Hoists Carefully

If you must work beneath raised equipment, use solid wood blocks, jack-stands or other rigid and stable supports. Never use concrete blocks. When using jacks or hoists, always be sure they are adequately supported and of adequate capacity.

Make sure the hoists or jacks you use are in good repair. Never use jacks with cracked, bent or twisted parts. Never use frayed, twisted or pinched cables. Never use bent, worn or distorted hooks.



Ventilate  
Work Area

## Protective Structure Safety

Do not remove or modify a protective structure (TOPS/ROPS, FOGS/FOPS OPS) except for service. Reinstall with manufacturer-approved fasteners before further machine operation.

Replace a damaged protective structure. Refer to the manufacturer's manual for specific instructions and inspection requirements.

# Perform Maintenance Safely

## Common Maintenance Safety Practices

### Fuel Hazards

**IMPORTANT!** Always use approved fuel containers and dispensing equipment.

Fuels are flammable, so observe these practices to reduce the possibility of a serious accident.

- Shut off engine and ignition before refueling.
- Always ground the fuel nozzle against the filler neck to avoid sparks.
- Keep sparks and open flames away from fuel.
- Do not use a cell phone or two-way radio while fueling or handling fuel—they could cause sparks.
- Do not smoke while refueling or when handling fuel containers.
- Do not cut or weld on or near fuel lines, tanks or containers.
- Do not overfill the tank or spill fuel. Clean up spilled fuel immediately.

Always use a nonflammable solvent when you clean parts. Do not use gasoline, diesel fuel or other flammable fluids.

Store all flammable fluids and materials away from work areas in suitable containers, per local regulations.

### Cooling System Hazards

Liquid cooling systems build up pressure as the liquid gets hot, so **use extreme caution** before removing the radiator or tank cap. Be sure to:

- Stop the engine and wait for the system to cool.
- Wear protective clothing and safety glasses.
- Turn the radiator or tank cap slowly to the first stop to allow the pressure to escape before removing the cap completely.



**Do Not  
Loosen Cap  
Until Cool**

# Perform Maintenance Safely

## Hydraulic System Hazards

The hydraulic system is under pressure whenever the engine is running and may hold pressure even after the engine is shut off. Cycle all hydraulic controls, including auxiliary controls, after the engine is shut down to relieve trapped pressure in the lines.

During inspection of the hydraulic system:

- Wait for fluid to cool before disconnecting the lines. Hot hydraulic fluid can cause SEVERE BURNS.
- **Do not** use your hand to check for leaks.
- Wear appropriate eye protection. Hydraulic fluid can cause permanent eye injury.

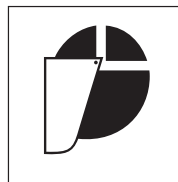
**WARNING!** Diesel fuel and hydraulic fluid under pressure can penetrate the skin or eyes and cause serious injury, blindness or death. Fluid leaks under pressure may not be visible. **Use a piece of cardboard or wood to find leaks, not your hand. Wear a face shield or safety goggles for eye protection.** If fluid is injected into the skin, it must be removed within a few hours by medical personnel familiar with this type of injury.

When venting or filling the hydraulic system, loosen the filler cap slowly and remove it gradually.

**Never** reset any relief valve in the hydraulic system to a pressure higher than recommended by the manufacturer.

Follow manufacturer's instructions when taking oil samples.

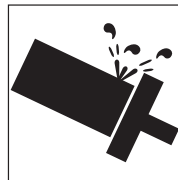
Do not permit an open flame around the hydraulic system.



**Wear  
Eye Protection**



**High Pressure  
Fluid Can Inject  
Into The Body**



**Do Not Exceed  
Factory Pressure  
Settings**

# Perform Maintenance Safely

## Electrical System Hazards

Before working on the electrical system, disconnect the battery cable(s).

- Remove the battery negative (-) cable(s) first.
- When reconnecting the battery, connect the battery negative (-) cable(s) last.

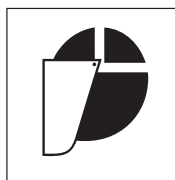
Battery electrolyte contains acid, which is a POISON and can cause SEVERE CHEMICAL BURNS.

## Avoid Injury

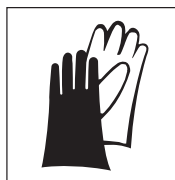
- Wear a face shield to prevent electrolyte contact with your eyes.
- Wear chemical-resistant gloves and clothing to keep electrolyte off your skin and regular clothing.

**WARNING!** Electrolyte will damage eyes or skin on contact. **Always wear a face shield to avoid getting electrolyte in eyes.** If electrolyte contacts eyes, flush immediately with clean water and get medical attention. **Wear rubber gloves and protective clothing to keep electrolyte off skin.** If electrolyte contacts exposed skin or clothing, wash off immediately with clean water.

If electrolyte is ingested, seek MEDICAL ATTENTION IMMEDIATELY. NEVER give fluids that would induce vomiting.



Wear  
Face Protection



Wear  
Protective  
Clothing

47

# Perform Maintenance Safely

## Avoid Battery Explosion

**WARNING!** Avoid possible death or serious injury from explosion. Lead-acid batteries produce extremely explosive gases, especially when being charged. **Keep arcs, sparks, flames and lighted tobacco away.**

- **Do not** smoke near batteries.
- Check battery cables for worn or damaged insulation.
- Keep arcs, sparks and open flames away from batteries.
- Provide adequate ventilation.

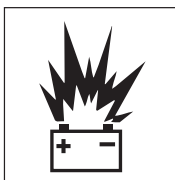
**Never** check the battery by placing a metal object across the battery posts; the resulting spark could cause an explosion.

**WARNING!** Avoid possible death or serious injury from battery explosion. **Do not charge a battery or boost-start the engine if the battery is frozen. Warm to 60°F (15.5°C) or the battery may explode.**

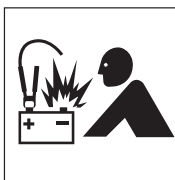
Safety rules during battery boost-starting:

- Follow the instructions for proper “battery boost-starting” as specified in the manufacturer’s manual.
- Be sure the machines are not touching.

- Observe the polarity of the batteries and connections.
- Make the final cable connection to the engine or the ground point farthest from the battery and away from fuel lines. Never make the final connection at the starter or dead battery—sparks may ignite the explosive gases present at the battery.
- When disconnecting cables after boost-starting, remove the cables in reverse order of connection (i.e., final connection first).



Avoid Sparks  
And Open Flames  
Near Batteries



Observe  
Polarity – Make  
Final Connection At  
Ground Point

# Perform Maintenance Safely

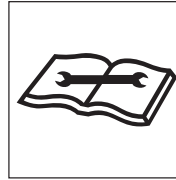
## Track Maintenance And Adjustment

Check the tracks daily because the stability of the compact excavator can be dramatically affected by damage to tracks.

Check for:

- Damage or wear
- Correct tension according to manufacturer's instructions
- Proper lubrication of track rollers and idlers—refer to the manufacturer's manuals.

Track tension is important for good performance, reducing excessive track wear and preventing the tracks from coming off. Track and roller wear varies with working conditions and soil conditions. Special tools and procedures may be needed to check or adjust track tension. Follow manufacturer's specific service procedure(s) when removing and installing tracks.



Follow  
Maintenance  
Instructions



Check For  
Track Damage

**WARNING!** Track tensioning systems have compressed springs or pressurized fluid (oil or grease). Improperly releasing track tension forces can result in death or serious injury. **Always follow the manufacturer's warnings and instructions for track adjustment and other maintenance and servicing procedures.**

**WARNING!** Avoid possible death or serious injury. **Never strike or pound on track tension springs.** They may be under very high compression and could shatter explosively.

49

# Perform Maintenance Safely

## Complete Service And Repairs Before Machine Is Released

Tighten all bolts, fittings and connections to torques specified by the manufacturer.

Clean or replace all damaged, missing or painted-over signs, plates and decals that cannot be read.

Inspect and install all guards, covers and shields after servicing. Replace or repair any damaged parts. Refill and recharge pressure systems only with manufacturer-approved or recommended fluids.

Check readiness of fire extinguishers, if so equipped. Do not paint over or otherwise interfere with fire detectors or fire extinguisher access points.

Follow the instructions in the manufacturer's manual(s) for proper service of any fire suppression equipment on the machine.

Air conditioning service is limited to approved service personnel. Refer to the manufacturer's manual(s).



Verify  
Service Work  
When  
Completed

Start the engine and check for leaks. (See page 46, **Hydraulic System Hazards**.) Operate all controls to make sure the machine is functioning properly. Test the machine if necessary. After testing, shut down and check the work you performed. Are there any missing cotter pins, washers, locknuts, etc.? Recheck all fluid levels before releasing the compact excavator for operation.

All parts should be inspected during repair and replaced if worn, cracked or damaged. Excessively worn or damaged parts can fail and cause death or injury.

## Final Word To The User

You have just finished reading the AEM Compact Excavator Safety Manual. It is impossible for this manual to cover every safety situation you may encounter on a daily basis. Knowledge of these safety precautions and your application to the basic rules of

safety will help to build good judgment in all situations. Our objective is to help you develop, establish and maintain good safety habits to make operating a Compact Excavator easier and safer for you.

This manual is another in a series on the safe operation of machinery published by AEM. Many pictorials in this safety manual can be found and downloaded at <http://pictorials.aem.org>. For additional publications visit our website at [www.safetymaterials.org](http://www.safetymaterials.org).

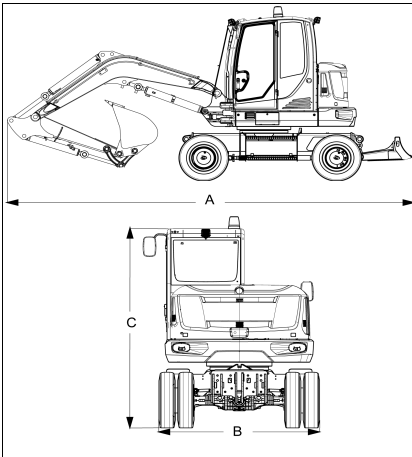


ASSOCIATION OF  
EQUIPMENT MANUFACTURERS

e-mail [safetymaterials@aem.org](mailto:safetymaterials@aem.org)  
[www.aem.org](http://www.aem.org)

**i** Information

The shipping document describes several basic settings and functions of the vehicle. The vehicle operator's manual contains further important safety instructions. The operator must familiarize themselves with all instructions and notices before commissioning the vehicle and adhere to them. The vehicle operator's manual must be completely read before commissioning the vehicle.



Dimension in mm (in)		EW65
A	Length with long stick (one-piece boom)	6137 (20'-6")
	Length with long stick (triple boom)	6349 (20'-10")
	Width (single tire 300)	1832 (72)
B	Width (single tire 425)	2001 (79)
	Width (twin tires)	2088 (82)
C	Height	2775 (9'-1")

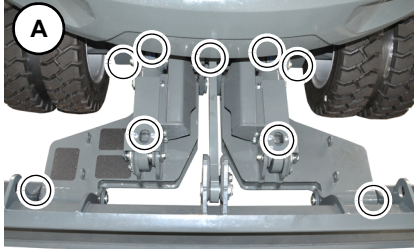
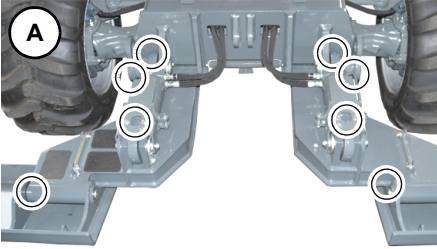
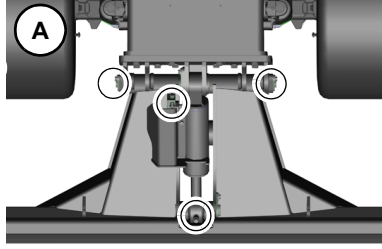
Weight kg (lbs)	One-piece boom	Triple articulation boom
Transport weight <sup>1</sup>	6472 (14,268)	6656 (14,674)
Operating weight <sup>2</sup>	6753 (14,888)	6940 (15,300)
Full fuel tank	+ 70 (154)	

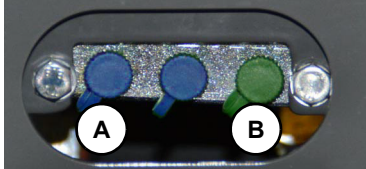
1. Transport weight: basic vehicle (one-piece boom, short stick, single tires 300) + 10% fuel tank capacity
2. Operating weight: basic machine + full fuel tank + bucket 800 mm/31 in + operator (75 kg/165 lbs)

**Lubrication points**

One-piece boom

Triple articulation

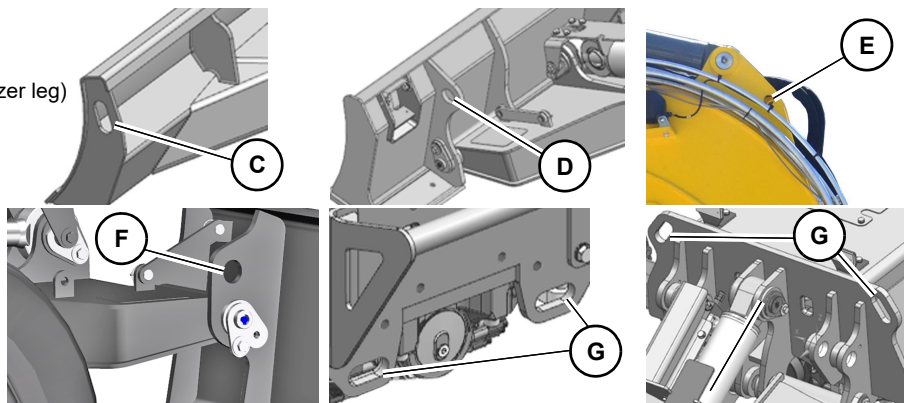
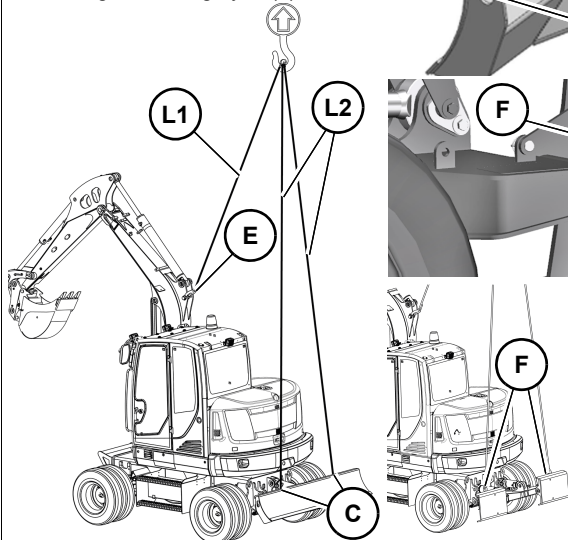


**A:** apply grease daily

**B:** apply grease once a week

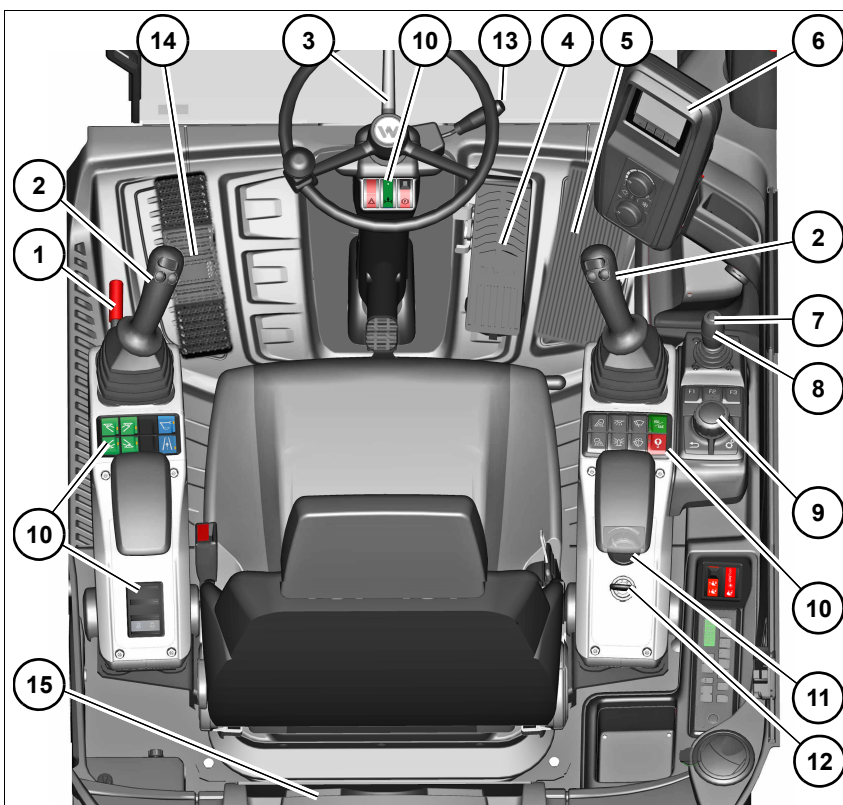
**Transportation**

- C: dozer blade lifting lugs (2)
- D: parallel dozer blade lifting lugs (2)
- E: boom lifting lugs (2/1)
- F: stabilizer leg lifting lugs (1 per stabilizer leg)
- G: travel gear lashing eyes (4)



		One-piece boom	Triple articulation boom
Stabilizer blade	L1	4100 mm (13'-5")	3900 mm (12'-10")
	L2	6000 mm (19'-8")	6000 mm (19'-8")
Stabilizer leg	L1	4400 mm (14'-5")	4200 mm (13'-9")
	L2	6300 mm (20'-8")	6300 mm (20'-8")

**Brief overview of operation**



Control elements	
1	Control lever base
2	Control lever left/right
3	Steering wheel
4	Brake pedal
5	Accelerator pedal
6	Multi-functional display (3.5" standard; 7" with optional reversing camera)
7	Speed range selection
8	Stabilizer-blade lever
9	Jog dial
10	Switch panel/button panel
11	Throttle
12	Ignition lock
13	Steering-column lever
14	Pedal for triple articulation boom (option)
15	Document box (option)

**NOTICE**

In order to avoid damage to the traveling drive, only change over between speed range 1 and 2 at machine standstill. Press the service brake.

Wacker Neuson Linz GmbH keep abreast of the latest technical developments and constantly improve their products. For this reason, we may from time to time need to make changes to figures and descriptions in this documentation that do not reflect products that have already been delivered and that will not be implemented on these vehicles.

Technical data, dimensions and weights are only given as an indication. Responsibility for errors or omissions not accepted.

No reproduction or translation of this publication, in whole or in part, without the written consent from Wacker Neuson Linz GmbH.

All rights under the provision of the Copyright Act are reserved.

Wacker Neuson Linz GmbH

Flughafenstraße 7

A-4063 Hörsching

Austria



**WACKER  
NEUSON**

*all it takes!*

 <b>WARNING</b>
Cancer and Reproductive Harm <a href="http://www.P65Warnings.ca.gov">www.P65Warnings.ca.gov</a>
 <b>ADVERTENCIA</b>
Cáncer y daño reproductivo <a href="http://www.P65Warnings.ca.gov">www.P65Warnings.ca.gov</a>
 <b>AVERTISSEMENT</b>
Cancer ou malformations congénitales <a href="http://www.P65Warnings.ca.gov">www.P65Warnings.ca.gov</a>

**Wacker Neuson Linz GmbH**

Flughafenstraße 7  
A-4063 Hörsching

Phone: +43 (0) 7221 63000  
Fax: +43 (0) 7221 63000-2200  
E-mail: [office.linz@wackerneuson.com](mailto:office.linz@wackerneuson.com)  
[www.wackerneuson.com](http://www.wackerneuson.com)

Order no. 5100024873  
Language us/us