

ALUMINIUM GANTRY CRANE

GB



USER INFORMATION

The assembly, operating and maintenance instructions for SCHILLING products must be observed at all times. Users and/or their personnel must read the instructions thoroughly and understand them fully before using the product.

Please retain this user information for future reference!



Contents

1. INTRODUCTION	1
1.1 MANUFACTURER	1
1.2 TERMS AND CONDITIONS	1
2. PRESENTATION OF INFORMATION	2
2.1 SYMBOLS AND TERMINOLOGY	2
2.2 INSTRUCTIONS FOR USE AND ENUMERATIONS	2
3. EC DECLARATION OF CONFORMITY	3
4. SAFETY	4
4.1 GENERAL SAFETY NOTES	4
4.2 APPROVED USE	5
4.3 NON APPROVED USE	5
5. TECHNICAL DATA	6
6. GENERAL DATA	7
7. DELIVERY AND TRANSPORT	8
7.1 SCOPE OF DELIVERY	8
7.2 TRANSPORTATION	8
7.3 STORAGE	8
8. OVERVIEW OF INDIVIDUAL COMPONENTS OF THE ALUMINIUM GANTRY CRANE	9
9. ASSEMBLY	10
10. PUTTING INTO OPERATION	21
10.1 COMPULSORY PRIOR INSPECTION AND TESTING	21
10.2 VISUAL INSPECTION, FUNCTION TEST	21
11. OPERATION	22
12. MAINTENANCE	23
12.1 MAINTENANCE PLAN	23
12.2 VISUAL INSPECTION, FUNCTION TESTING AND STRESS TESTING	23
12.3 INSPECTION REPORT / REPEAT INSPECTION	24
13. DISASSEMBLY AND DISPOSAL	27
13.1 DISASSEMBLY	27
13.2 DISPOSAL	27
13.3 DISPOSAL OF PACKAGING MATERIAL	27
14. SERVICE	28
14.1 CONTACT	28
14.2 SPARE PARTS ORDERING OR REORDERING PROCESS	28

1. Introduction

- ▲ The Aluminium Gantry Crane is used for lifting, lowering and moving loads with a trolley. The Aluminium Gantry Crane is only permitted to be used on flat and solid surfaces.
- ▲ This user information constitutes an integral part of the product and an element of the overriding risk assessment and handling instructions to be taken into account whenever lifting or handling loads.
- ▲ The user information must be available to all users.
- ▲ Please read this user information thoroughly before using the Aluminium Gantry Crane.
- ▲ This user information explains how to safely assemble, operate, maintain, repair, disassemble and dispose of the Aluminium Gantry Crane.
- ▲ In addition to this user information, you must also observe and comply with all applicable occupational health and safety regulations of the country and the environment in which the Aluminium Gantry Crane is used as well as all other general regulations and rules regarding safe and appropriate use.
- ▲ Images and illustrations in this user information may differ from the actual product which will be supplied.
- ▲ Unauthorized modifications of the Aluminium Gantry Crane or self-made auxiliary equipment are prohibited.

1.1 Manufacturer



1.2 Terms and Conditions

- ▲ In the event of direct sales transactions, the General Terms and Conditions can be obtained from the manufacturer or from their website.
- ▲ If you have purchased your device from an intermediary, please ask your distributor/salesperson.

2. Presentation of information

This user information uses symbols, terminology, instructions for use and enumerations as described in Chapters 2.1 to 2.2 below.

2.1 Symbols and terminology

Safety notes

Safety notes are categorised and presented as follows:

HAZARD

A safety note designated as a “HAZARD” indicates a risk which will directly and with certainty lead to death or severe, permanent personal injury.

WARNING

A safety note designated as a “WARNING” indicates a risk which may lead to severe personal injury or death.

CAUTION

A safety note designated as a “CAUTION” indicates a risk which may lead to minor to moderate personal injury.

NOTE

A safety note designated as a “NOTE” indicates a risk which may lead to material damage.

Useful information and tips



INFO

This symbol indicates useful information and tips.

Disposal



INFORMATION FOR DISPOSAL

of packaging materials, lifting devices, etc.

2.2 Instructions for use and enumerations

All instructions for use are presented in chronological order and numbered, e.g.:

1. Step 1

2. Step 2

Outcomes of actions are indicated by an arrow:

➤ Outcome or device response

Instructions for use which do not have to be carried out in a particular sequence are indicated as follows:

- Step

- Step

Outcomes of actions are indicated by an arrow:

➤ Outcome or device response

Enumerations are indicated by indents:

- Enumeration

3. EC Declaration of Conformity

EC Declaration of Conformity

Pursuant to the EC Machinery Directive 2006/42/EC, Appendix II A

We hereby declare that the below mentioned machine complies with the general health and safety requirements of EC Directive 2006/42/EC in terms of its design and construction and in the version marketed by us.

This declaration shall become invalid in the event of modifications to the machine without our prior approval.

Manufacturer:



Description and identification of the machine:

- Function: Aluminium Gantry Crane with trolley for lifting of loads, 1000 kg - 3000 kg
- Type/Model: Aluminium Gantry Crane, stationary, medium
- Item number: 10251500015024 (*8030.5H.10S*), 10251500015030 (*8030.6H.10S*)
10251500015023 (*8030.5H.10*), 10251500015029 (*8030.6H.10*)
10251500015026 (*8030.5H.20S*), 10251500015032 (*8030.6H.20S*)
10251500015025 (*8030.5H.20*), 10251500015031 (*8030.6H.20*)
10251500015028 (*8030.5H.30S*), 10251500015034 (*8030.6H.30S*)
10251500015027 (*8030.5H.30*), 10251500015033 (*8030.6H.30*)

* *italic written item number is discontinued item number*

- Serial number: 1210/2020

- Year of manufacture: 2020

Applied harmonised standards, in particular:

- DIN EN 13001-1:2015-06 – Cranes – General design – Part 1: General principles and requirements
- DIN EN 13001-2:2014-12 – Cranes – General design – T2 Load actions
- DIN EN 15011:2014-09 – Cranes – Bridge and Gantry Cranes
- DIN EN 1999-1-1:2014-03 – Design of aluminium structures – General structural rules

Applied national standards and technical specifications, in particular:

- DGUV Vorschrift (regulations) 52 (BGV D6) – UVV Krane (Cranes)

Information about the authorised signatory:

- Martin Schilling, Ernst-Zimmermann-Strasse 9-11, 88045 Friedrichshafen, Germany
(Business owner)

Date:
07.12.2020

Signature:

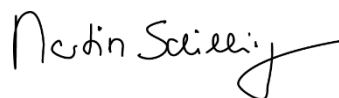

4. Safety

Please read the safety instructions below thoroughly before putting the product into operation.

Chapters 4.1 to 4.3 set out general rules of conduct to be adhered to when handling the product. Instructions in the following chapters highlighted with a  symbol must be followed in order to avoid putting persons and materials at risk. Safety notes pertaining to individual instructions for use are listed before the relevant step and must be observed.

4.1 General safety notes

- Read this user information in full.
- Observe the safety notes.
- Ensure that this user information is available at the site of operation at all times.
- The product must be operated by suitably qualified personnel (see Tab. 1) only.
- In addition to this user information, you must also observe and comply with all applicable occupational health and safety regulations of the relevant country and environment in which the product is used, as well as other general regulations for safe and appropriate use.
- Any damage compromising safety must be repaired immediately.
- Perform all work prudently.
- Never open a lifting device when loaded.
- Never stand/walk below the suspended load.

Qualifications required for handling lifting devices

<i>Field of activity</i>	<i>Qualification</i>	<i>Specialist knowledge</i>
<i>Delivery and transport</i>	<i>Dealer, freight carrier</i>	<i>– Evidence of load safety induction – Safe handling of lifting devices</i>
<i>Storage</i>	<i>Warehouse staff</i>	<i>– Safe handling of lifting devices</i>
<i>Assembly, commissioning, maintenance, repair and disassembly</i>	<i>Qualified personnel</i>	<i>– Expert: technical training and expertise, sufficient knowledge about lifting devices – Safe handling of lifting devices – Product-specific knowledge</i>
<i>Operation, simple visual inspection</i>	<i>Qualified personnel</i>	<i>– Safe handling of lifting devices, technical training and expertise</i>
<i>Disposal</i>	<i>Qualified personnel</i>	<i>– Knowledge about the regulations for correct disposal and recycling</i>

Tab. 1: Overview

4.2 Approved use

- The lifting, lowering and moving loads with a trolley. The Aluminium Gantry Crane is only permitted to be used on flat and solid surfaces
- The stated load capacity must be observed
- Temperature ranges from -20° to +50°C
- Wind speeds of up to < 40 km/h
- When using the gantry crane, make sure that the beam length between the side frames is always at least 1.6 times the beam length outside the side frames.

4.3 Non approved use

- Exceeding the maximum load capacity
- Structural modifications of the product
- Standing/walking below the suspended load
- Pulling a load diagonally
- Forcefully freeing loads that are stuck
- Dragging loads along the ground
- Transporting persons and animals

No guarantee is provided for the completeness of Chapter 4.3.

Anything that is not explicitly permitted is classified as non approved use.

5. Technical data

Aluminium beam:
separable/pluggable

Aluminium beam:
one piece

Aluminium beam:
separable/pluggable

Aluminium beam:
one piece

Item number „Version 1000 kg“	10251500015024 (8030.5H.10S)	10251500015023 (8030.5H.10)	10251500015030 (8030.6H.10S)	10251500015029 (8030.6H.10)
Load capacity	1000 kg	1000 kg	1000 kg	1000 kg
Beam length	4000 mm	4000 mm	6000 mm	6000 mm
Total weight	172 kg	162 kg	224 kg	214 kg
Item number „Version 2000 kg“	10251500015026 (8030.5H.20S)	10251500015025 (8030.5H.20)	10251500015032 (8030.6H.20S)	10251500015031 (8030.6H.20)
Load capacity	2000 kg	2000 kg	2000 kg	2000 kg
Beam length	4000 mm	4000 mm	6000 mm	6000 mm
Total weight	258 kg	248 kg	294 kg	284 kg
Item number „Version 3000 kg“	10251500015028 (8030.5H.30S)	10251500015027 (8030.5H.30)	10251500015034 (8030.6H.30S)	10251500015033 (8030.6H.30)
Load capacity	3000 kg	3000 kg	3000 kg	3000 kg
Beam length	4000 mm	4000 mm	6000 mm	6000 mm
Total weight	258 kg	248 kg	294 kg	284 kg

Note:

Italic written item number is discontinued item number

6. General data

The following data is engraved on the individual components of the Aluminium Gantry Crane:

- | | |
|-------------------------|-------------------------------|
| A: Load capacity | B: Year of manufacture |
| C: Type | D: Total weight |
| E: Serial number | |

Example of a Carl Stahl engraving:

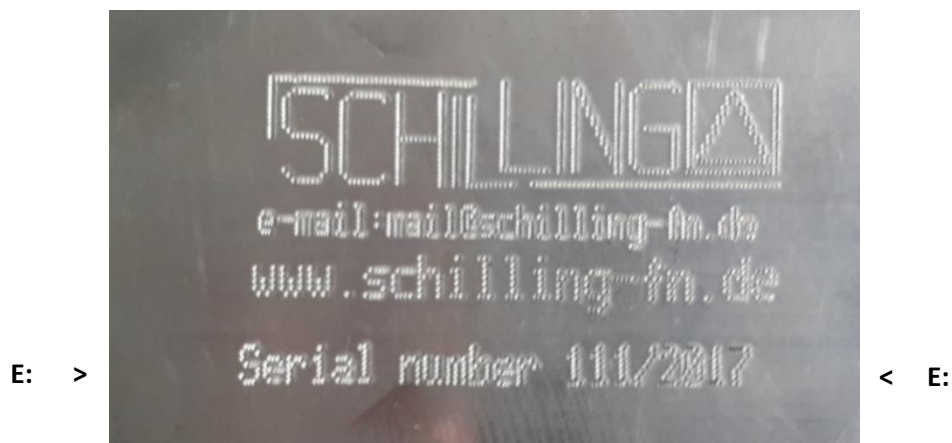
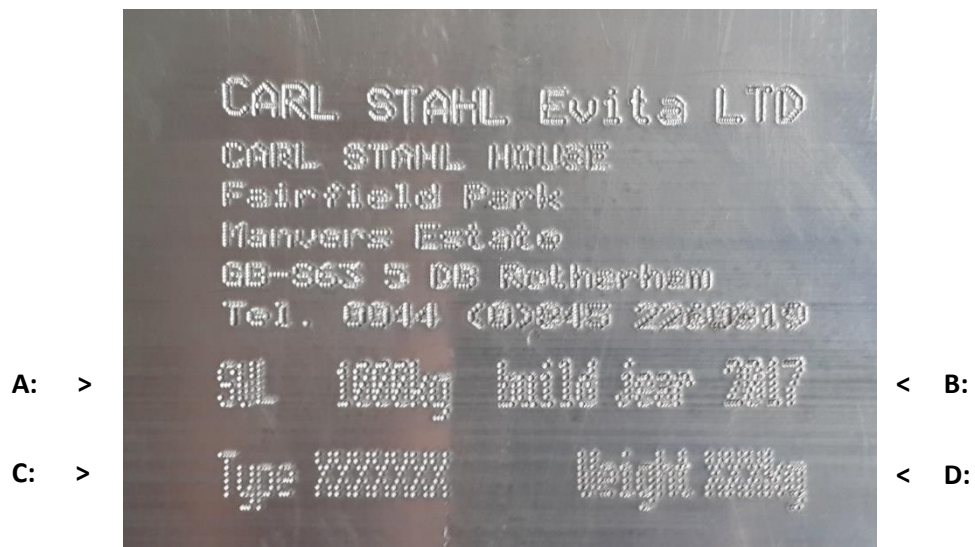

7. Delivery and transport

7.1 Scope of delivery

Immediately check the delivery for completeness against the enclosed delivery note. You may also use the overview of the product and the parts list in order to verify the completeness of the delivery (see Chapter 8).

If parts are missing, please contact your supplier immediately.

If notified late, especially if the product has already been used, we cannot accept any claims for after supply.

7.2 Transportation

The product is checked and adequately packaged prior to delivery.

NOTE

Damage to the device

Incorrect transportation may damage the product.

- Always transport the product as intended.
- Use a suitable means of transport.
- Make sure that the product is adequately secured during transportation.

7.3 Storage

NOTE

Damage to the device

Incorrect storage may damage the product.

- Always store the product as intended.
- Store the product in a clean and dry place.
- Protect the product from:
 - constant humidity or outdoor storage
 - contamination
 - damage
 - corrosion

8. Overview of individual components of the Aluminium Gantry Crane

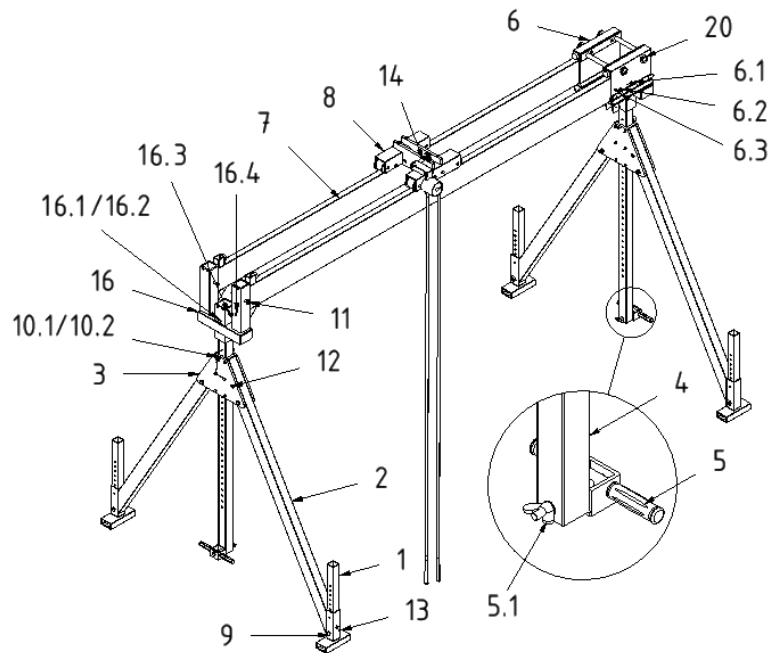

Parts List:

Item	Name	Quantity	Item	Name	Quantity
1	Adjusting feet	4	10.1	Bolt (unlosable), D16, for beam support (1000 – 1500 kg)	2
2	Stand brace	4	10.2	Bolt (unlosable), D20, for beam support (2000 – 3000 kg)	2
3	Plastic plates (trapezium)	2	11	Bolt (unlosable), D16, for aluminium beam	2
4	Beam support	2	12	Push bolt	4
5	Lifting handle	2	13	Clip pin	4
5.1	Wing nut, M16	2	14	Suspension bolt (unlosable), for trolley	1
6	Horizontal adjuster	1	16	Beam mountings	1
6.1	Bolt, M16x130	1	16.1	Bolt, M16x130 (1000 – 1500 kg)	1
6.2	Washer, M16	2	16.2	Bolt, M16x150 (2000 – 3000 kg)	1
6.3	Wing nut, M16	1	16.3	Washer, M16	2
7	Aluminium beam	2	16.4	Wing nut, M16	1
8	Park brake trolley	1	20	Star knob	4
9	Bolt, D16, for adjusting feet	4			

Position 5.1 applies only to “Version high”, and “Version 2000/3000 kg” Cranes, Item numbers 153xxxx.

For separable/pluggable beam versions, an additional assembly instruction is attached in Chapter 9.

Additional information on the accessory wheel kit for Aluminium Gantry Cranes can be found in Chapter 9.

9. Assembly

CAUTION

The Aluminium Gantry Crane has pinching points which may cause injuries.

- Perform all assembly work prudently and cautiously.



INFO

Recommended personnel, tools and aids for assembling the Aluminium Gantry Crane:

- At least 2 people
- Socket or open-end wrench (*if necessary*)
- Step ladder or similar (*if necessary*)

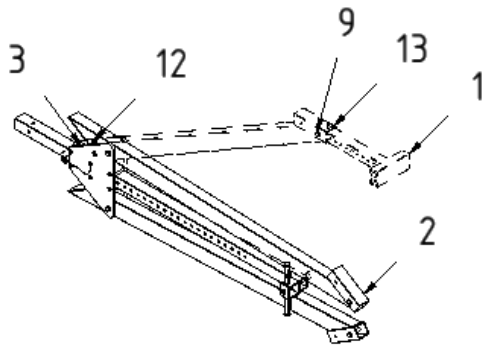

1. First lateral stand unfolding (one side) and insertion of the first adjustment foot (*alternative wheel kit*):

1.1.

Push in the pressure pin (12) on the upper stand brace (2) of the lateral stand.

1.2.

Fold the stand brace (2) outwards (*upwards*) until the push bolt (12) clicks and locks into the hole of the plastic plate (3).

1.3.

Insert an adjustment foot (1) from below into the unfolded stand brace (2).

1.4.

Secure the adjustment foot (1) using a bolt (9) with a clip pin (13).

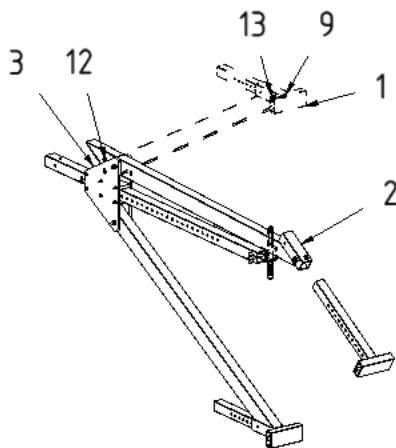

2. First lateral stand unfolding and second adjustment foot (*alternative wheel kit*) insertion:

2.1.

Turn the lateral stand 180 degrees.

2.2.

Insert the second adjustment foot (1) from below into the not yet unfolded stand brace (2).

2.3.

Secure the adjustment foot (1) using a bolt (9) with a clip pin (13).

2.4.

Push in the push bolt (12) on the upper stand brace (2) of the lateral stand.

2.5.

Fold the stand brace (2) outwards (*upwards*) until the push bolt (12) clicks and locks into the hole of the plastic plate (3).

⚠ CAUTION

The Aluminium Gantry Crane has pinching points which may cause injuries.

- Perform all assembly work prudently and cautiously.

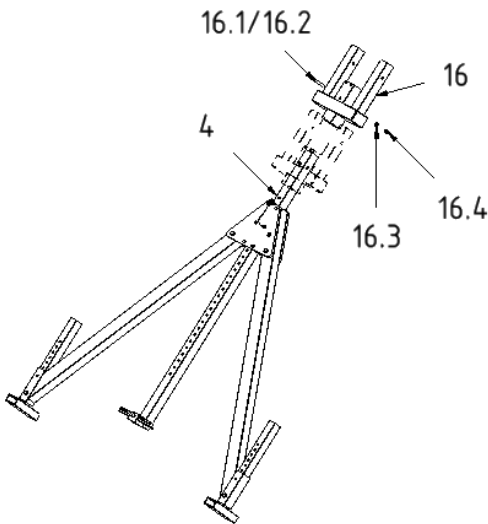

3. Lifting the first lateral stand and attaching the beam mounting:

3.1.

Erect the lateral stand and tilt it slightly.

3.2.

Slide the beam mounting (16) onto the beam support (4) of the lateral stand.

3.3.

Secure the beam mounting (16) onto the beam support (4) using bolts (16.1/16.2), two washers (16.3) and wing nuts (16.4).



INFO on assembly step 4

Lateral stands with manual winch (if ordered):

- When the lateral stands are erected the winches must face outwards.

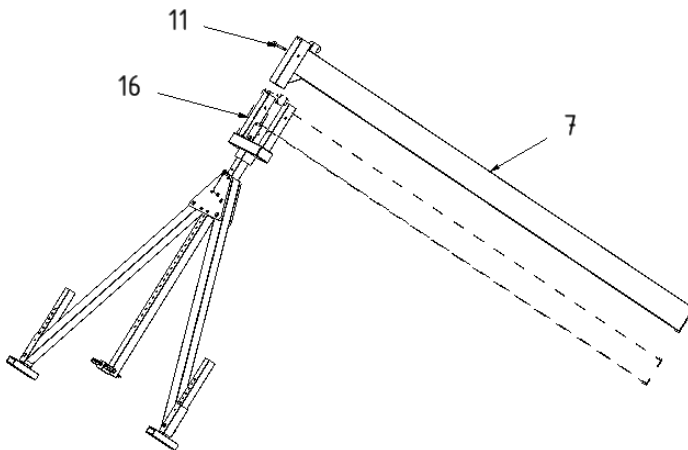

4. Placing the first beam on the beam mountings:

4.1.

Hold the lateral stand in an inclined position.

4.2.

Slide the beam housing (*aluminium square profile*), found welded on the end of the beam (7), onto the beam mounting (16).

4.3.

Insert the bolt (11) into the hole in the beam housing of the beam (7) to secure the beam.

5. Assembly of the second lateral stand:

5.1.

For the second lateral stand repeat steps 1.1. – 2.5.

CAUTION

The Aluminium Gantry Crane has pinching points which may cause injuries.

- Perform all assembly work prudently and cautiously.



INFO on assembly step 6

Lateral stands with manual winch (if ordered):

- When the lateral stands are erected the winches must face outwards.

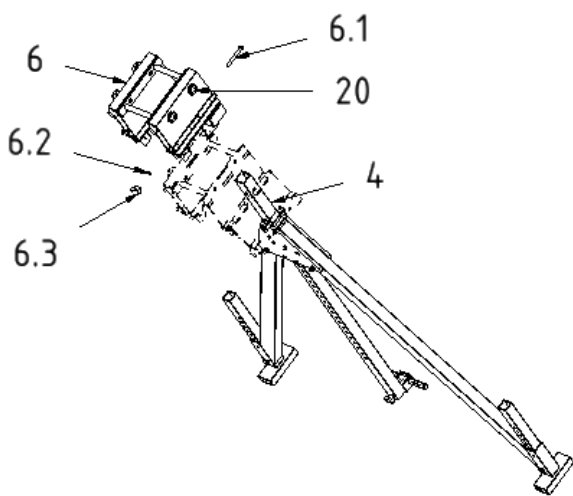

6. Lifting the second lateral stand and attaching the horizontal adjuster:

6.1.

Erect the lateral stand and tilt it slightly.

6.2.

Slide the horizontal adjuster (6) onto the beam support (4) of the lateral stand (*bump stop facing inwards*).

6.3.

Secure the horizontal adjuster (6) onto the beam support (4) using bolts (6.1), two washers (6.2) and wing nut (6.3).

6.4.

Open the horizontal adjuster (6) using the blue star knobs (20).

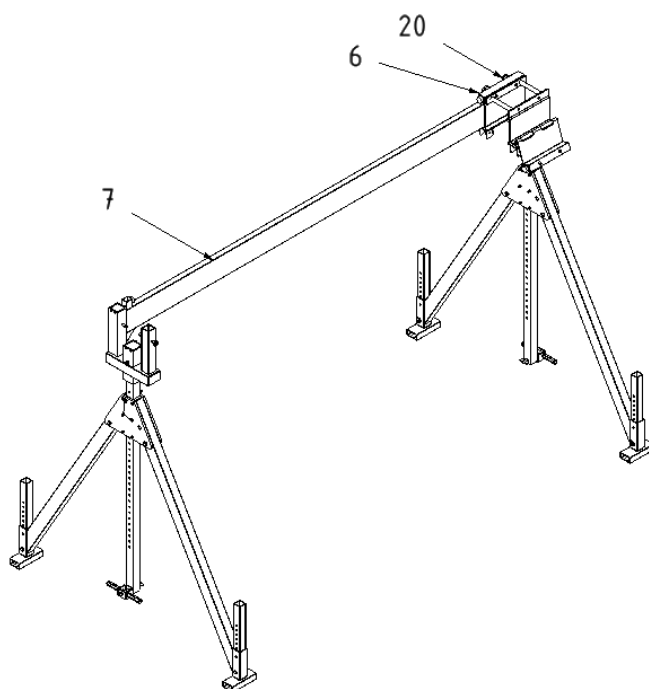

7. Erecting the second lateral stand and placing the first beam in the horizontal adjuster:

7.1.

Fully erect the second lateral stand fitted with the horizontal adjuster (6).

7.2.

Lift the free end of the beam (7) which is attached to the first lateral stand.

7.3.

With the help, if needed, of e.g. a step ladder, lay the end of the beam (7) into the lower part of the already open horizontal adjuster (6).

7.4.

Close the lid of the horizontal adjuster (6).

7.5.

Securely clamp the beam (7) in the horizontal adjuster (6) by tightening the blue star knobs (20).

⚠ CAUTION

The Aluminium Gantry Crane has pinching points which may cause injuries.

- Perform all assembly work prudently and cautiously.

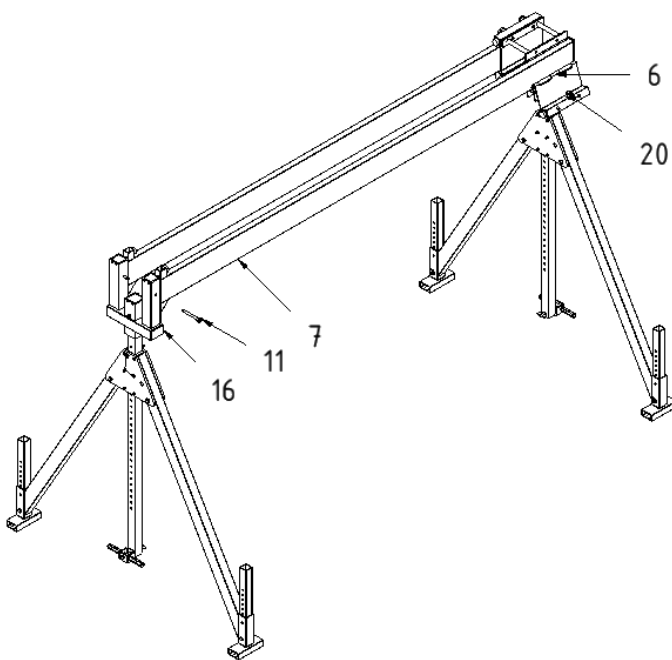

8. Mounting the second beam:

8.1.

Lift the second beam (7).

8.2.

Step onto, if needed, e.g. a step ladder.

8.3.

Slide the beam housing (aluminium square profile) found welded on the end of the beam (7) onto the beam mounting (16) and lay the other end of the beam (7) into the lower part of the already open horizontal adjuster (6).

8.4.

Insert the bolt (11) into the hole in the beam housing of the beam (7) to secure.

8.5.

Close the lid of the horizontal adjuster (6).

8.6.

Securely clamp the beam (7) in the horizontal adjuster (6) by tightening the blue star knobs (20).

⚠ CAUTION

The Aluminium Gantry Crane has pinching points which may cause injuries.

- Perform all assembly work prudently and cautiously.

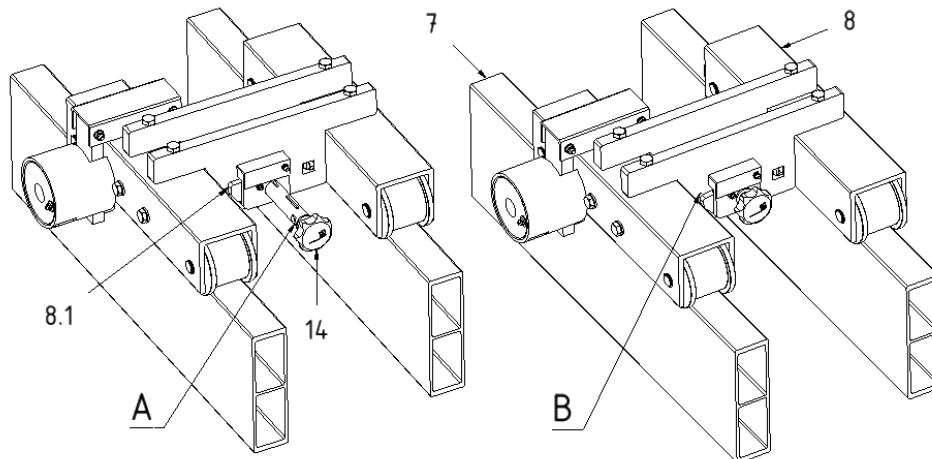

9. Placing the trolley on the beams:

9.1.

Place the trolley (8) onto the 2 beams (7).

9.2.

Press the locking mechanism (8.1) upwards and pull out the suspension bolt (14).

9.3.

Position your lifting device between the guidance plates of the trolley (8).

9.4.

Re-insert the suspension bolt (14) into the hole.

9.5.

Ensure that after the re-insertion of the suspension bolt (14) that the locking mechanism (8.1) has snapped shut on the bolt groove (A).

9.6.

When the locking mechanism (8.1) has locked on the bolt groove (A) the safety hole (B) can be seen.

9.7.

Secure the trolley (8) against unwanted rolling by pulling firmly on the red band.

⚠ CAUTION

The Aluminium Gantry Crane has pinching points which may cause injuries.

- Perform all assembly work prudently and cautiously.



INFO on assembly step 10

For Aluminium Gantry Cranes, “Version small” (151xxxx) and “Version medium” (152xxxx)

- The 2 lifting handles (5) are already welded to the beam support (4).

For Aluminium Gantry Cranes, “Version high” and “Version 2000 kg/3000 kg” (153xxxx)

- The 2 lifting handles (5) must first be secured to the beam support (4) with a wing nut (5.1).

For lateral stands with hand winches (if ordered)

- Height adjustment is according to the attached separate user manual.

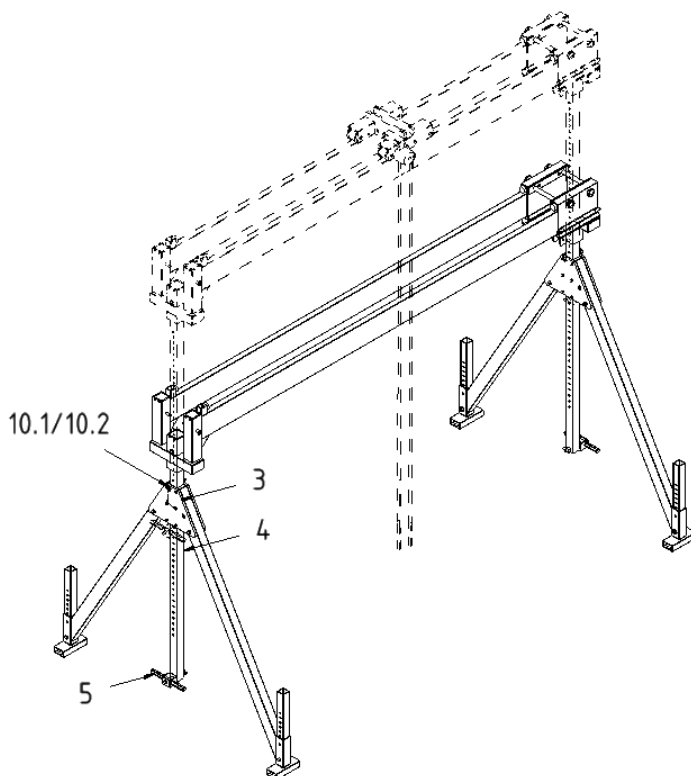

10. Height adjustment of the Aluminium Gantry Crane:

10.1. (with lifting handles)

Pull out the 2 bolts (10.1/10.2) from the beam supports (4). Simultaneously lift the 2 beam supports (4) with the lifting handles (5) and secure the required height with the bolts (10.1/10.2). *(Pay attention after inserting the bolts (10.1/10.2) that only the steel portion of the bolt lays in the groove of the plastic plates (3) and not on the plastic handle of the bolt.)*

10.2. (with hand winches)

Height adjustment is according to the attached separate user manual.

Caution:

Before applying load to the crane the bolts (10.1/10.2) must always lay correctly in the plastic plates (3) and the rope of the winch must not be under tension.



➤ **Now the Aluminium Gantry Crane is fully assembled.**

➤ **Disassemble in reverse order.**

Additional assembly instruction for separable/pluggable beam versions (if ordered)



INFO

Recommended personnel, tools and aids for assembling the separable/pluggable aluminium beam:

- M10 hexagonal socket wrench (allen key)

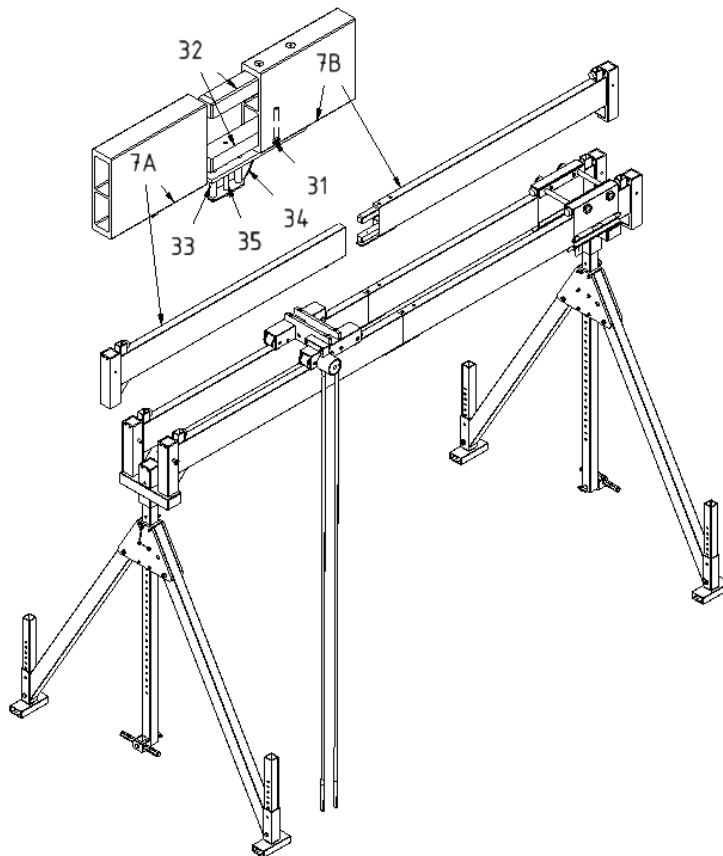

Parts list:

Item	Name	Number of pieces	Item	Name	Number of pieces
7A	Aluminium beam (part A)	2	33	Fixing element	2
7B	Aluminium beam (part B)	2	34	Securing rope	2
31	Socket bolt, M10	4	35	Socket bolt, M10	2
32	Connecting element	4			

**The following instructions describe the assembly of separable/pluggable aluminium beams.
Disassemble in reverse order.**

Step 1: Loosen the socket bolt (31) to loosen the bottom connecting element (32) so that you can more easily connect the aluminium beam (7B) with the aluminium beam (7A).

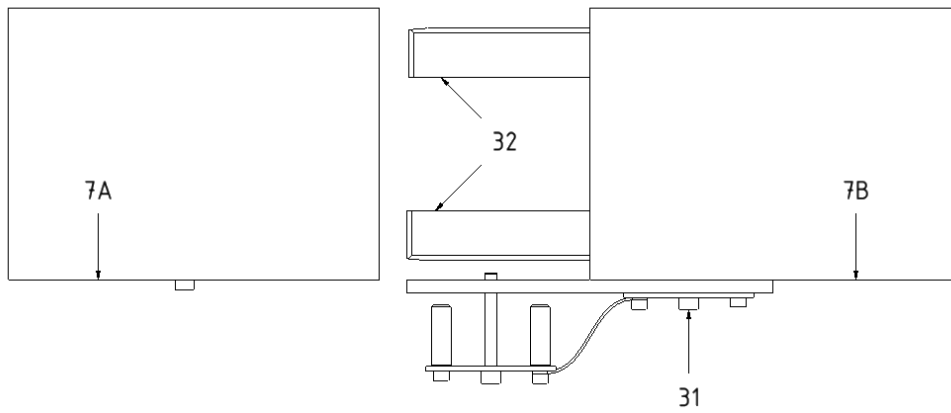

Step 2: Insert the connecting element (33), which is secured against loss by a securing rope (34), into the holes on aluminium beam (7A), and fix it with the socket bolt (35).

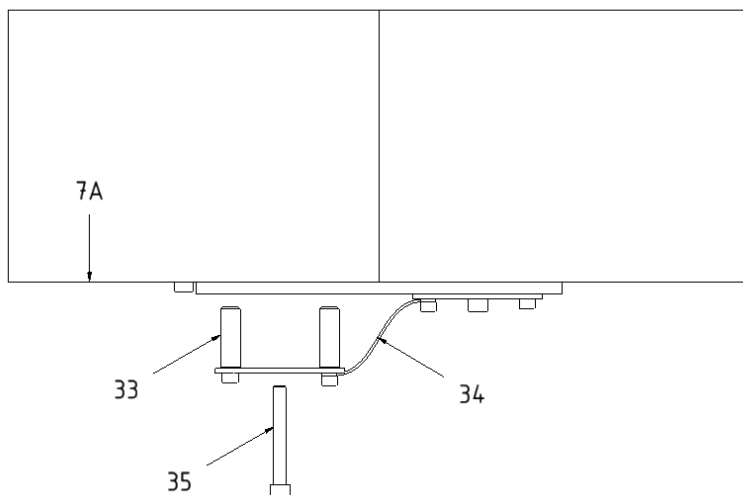

Step 3: Firmly tighten the socket bolts (31 + 35).

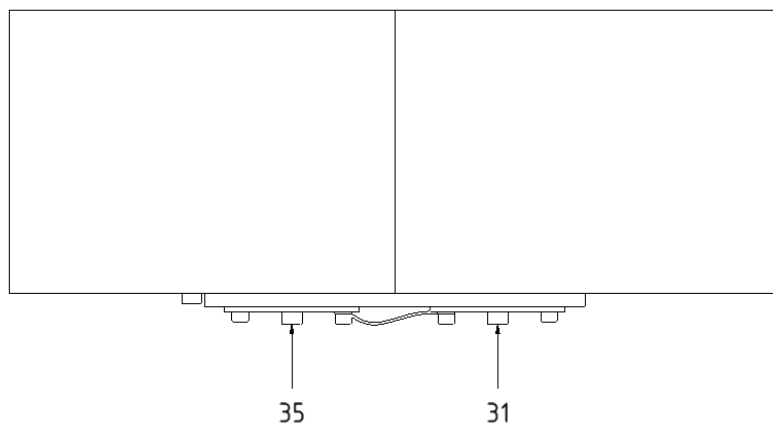

Additional Information

Wheel Kit for Aluminium Gantry Crane (if ordered)

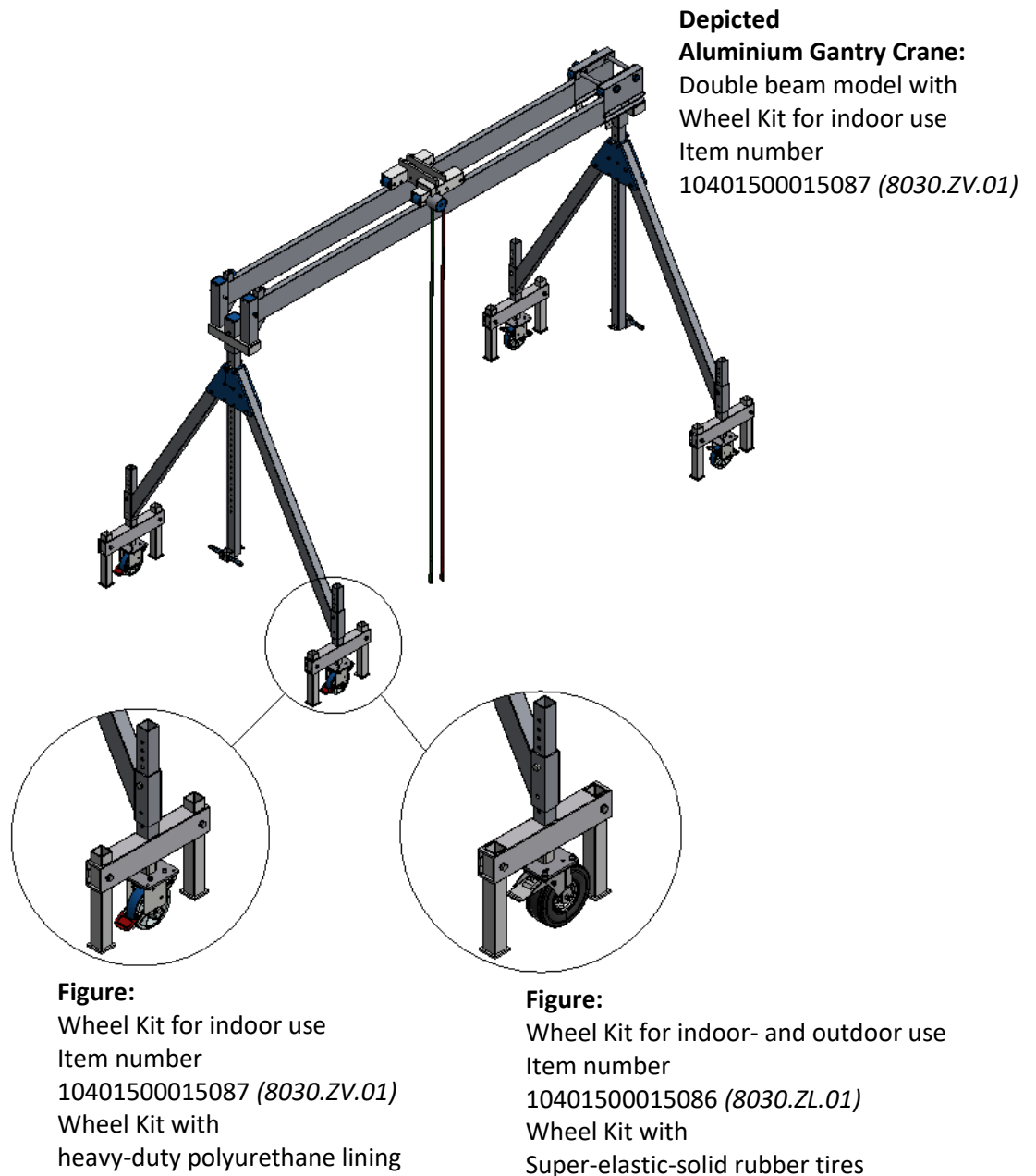

**Item No. 10401500015087 (8030.ZV.01) – Indoor:
Wheel Kit with heavy-duty polyurethane lining**

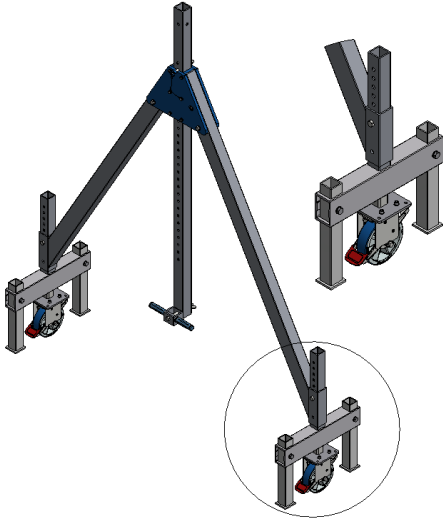

- For indoor moving and positioning of the Aluminium Gantry Crane without load
- 4 steel swivel casters
- with integrated caster and swivel head brake
- own weight 70 kg

Attention:

- When using this Wheel Kit together with our Aluminium Gantry Cranes
 - the minimum suspension point at the bolt of the trolley is increased by 400 mm
 - the maximum suspension point at the bolt of the trolley is increased by 200 mm
- the adjustment range of the Wheel Kit feet is 200 mm

**Item No. 10401500015086 (8030.ZL.01) – Indoor and Outdoor:
Wheel Kit with super-elastic-solid rubber tires**

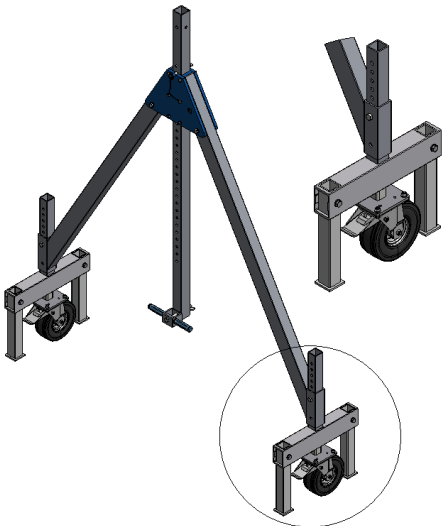

- For indoor and outdoor moving and positioning of the Aluminium Gantry Crane without load
- 4 steel swivel casters
- heavy duty tires with groove profile
- with integrated caster and swivel head brake
- own weight 80 kg

Attention:

- When using this Wheel Kit together with our Aluminium Gantry Cranes
 - the minimum suspension point at the bolt of the trolley is increased by 440 mm
 - the maximum suspension point at the bolt of the trolley is increased by 240 mm.
- the adjustment range of the Wheel Kit feet is 200 mm

Description:

- Facilitates moving of the fully assembled Aluminium Gantry Crane without load.
- The leg and fork construction permits the lateral stands to remain upright when assembling and disassembling.
- The unloaded Aluminium Gantry Crane can easily be moved to the working area.
- The Wheel Kit spares any assembly and disassembly work.
- The spring mounted guide rolls allow the lateral stands to rest directly on the feet when under load.
- The adjustment feet are individually height adjustable.
- 1 Wheel Kit = 4 „forks“.

10. Putting into operation

10.1 Compulsory prior inspection and testing

Inspection and testing of the Aluminium Gantry Crane is required prior to commissioning in order to ensure that the Aluminium Gantry Crane has been fully and correctly assembled.

In addition, this ensures that the Aluminium Gantry Crane is in perfect working order and ready for its intended use.

WARNING

Without prior inspection and testing, injuries may occur during commissioning.

Inspect and test the Aluminium Gantry Crane as follows:

- Visual inspection
- Function test

10.2 Visual inspection, function test

Visual inspection

The Aluminium Gantry Crane must be inspected every time before putting it back into operation.

CAUTION

The Aluminium Gantry Crane has pinching points which may cause injuries.

- Perform all inspections and testing of the Aluminium Gantry Crane prudently and cautiously.
1. The aluminium beams must be aligned horizontally.
 2. The beam supports of the lateral stands must be aligned vertically.
 3. Prior to loading the Aluminium Gantry Crane, all bolts must have been inserted and (if necessary) secured with clip pins.
 4. The push bolts must have snapped into the plastic (trapezoidal) plates.
 5. In particular, check load bearing parts for damage and broken weld seams.
 6. Terminate operation in the event of faults. Faults must be eliminated by qualified personnel.

Function test

The Aluminium Gantry Crane must be tested every time before putting it back into operation.

WARNING

Loads may fall in the event of deformation and wear of individual components.

- Take the Aluminium Gantry Crane out of operation immediately.
 - Have the device inspected and tested by a qualified expert.
1. Check that the brake on the trolley is functioning (green > open / red > closed).
 2. Verify to what extent the individual components are still functional.
 3. If in doubt, replace individual components.
 4. Verify that all movable parts are able to move freely.
 5. Replace parts which do not move freely.
 6. Put the Aluminium Gantry Crane out of operation if no longer functional or damaged beyond repair.
 7. Dispose of the individual material components (see Chapter 13).

11. Operation

The Aluminium Gantry Crane can be used as intended once it has been properly assembled and put into operation.

CAUTION

The Aluminium Gantry Crane has pinching points which may cause injuries.

- Operate the Aluminium Gantry Crane prudently and carefully.

WARNING

Various hazards may occur in connection with the Aluminium Gantry Crane.

- If the trolley brake is not engaged and the aluminium beam is at a slight incline, the trolley can move unexpectedly.
- If the Aluminium Gantry Crane is not operated as intended, injuries may occur when adjusting the beam supports.
- Select the distance between the two lateral stands so that the stability of the Aluminium Gantry Crane is ensured.
- If faults are identified at welded joints, a supporting part may break, causing the load to fall and potentially result in severe personal injury.

DANGER

Never work below a load on the Aluminium Gantry Crane.

- Never stand/walk below the suspended load

The Aluminium Gantry Crane is used for lifting, lowering and moving loads with a trolley.
The Aluminium Gantry Crane is only permitted to be used on flat and solid surfaces.

12. Maintenance

The product is essentially maintenance free.

12.1 Maintenance plan

Maintenance date	Action
Prior to putting into operation	- Visual inspection and function testing by qualified personnel
Prior to each subsequent operation, after initial putting into operation without any prior extraordinary incidents	- Visual inspection by qualified personnel
Annually	- Visual inspection, function testing and stress test performed by a qualified expert

12.2 Visual inspection, function testing and stress testing

Visual inspection

See Chapter 10.2

Function testing

See Chapter 10.2

Stress testing according to the relevant guidelines

The product must be subjected to stress tests at least once a year, and immediately in the event of modifications or repairs.

WARNING

Operators of the product are required to comply with statutory regulations.

- Have the device professionally inspected by a qualified expert (see Chapter 12.3)

1. Operators of the product must ensure that the product is inspected by a qualified expert at least once a year and that any faults identified during these inspections are eliminated immediately.
2. (Where applicable) The guidelines of the DGUV Vorschrift (regulations) 52 (BGV D6) – UVV Krane (cranes), must be observed.

12.3 Inspection report / repeat inspection

Product: **Aluminium Gantry Crane, stationary,
with lateral stand, collapsible,
incl. top mounted park-break trolley,
incl. integrated horizontal adjuster.**

Manufacturer: SCHILLING Kran- und Hebeteknik GmbH, – www.schilling-fn.de

Year of manufacture: 2020

Please check the engraving on the product for the item number, load capacity, serial number and net weight of the device.

- 1) Inspection prior to delivery.
Visual inspection and function testing of the product and its components have been performed.
The product has been developed, constructed and built in accordance with the rules of engineering.



Date: Date of dispatch (see delivery note)

Owner's/Manufacturer's signature

- 2) Repeat inspection
Inspection has been performed

Date:

Signature of the qualified expert

- 3) Repeat inspection
Inspection has been performed

Date:

Signature of the qualified expert

- 4) Note
Inspection has been performed

Date:

Signature of the qualified expert

Next inspection: 1 year after delivery (at the latest)

Product: Aluminium Gantry Crane, stationary,
with lateral stand, collapsible,
incl. top mounted park-break trolley,
incl. integrated horizontal adjuster.

Manufacturer: SCHILLING Kran- und Hebetchnik GmbH, – www.schilling-fn.de

Year of manufacture: 2020

Please check the engraving on the product for the item number, load capacity, serial number and net weight of the device.

Findings / drawing					
Known faults have been fixed by -us / -the company. Date and signature of the operations manager:					
There is -no- reason to object to continued operation. Re-inspection is -not- required. Date and inspector's signature:					
Acknowledged. Date and signature of the operations manager:					
Participants:	Yes	No	Inspection according to Art.	Yes	No
Rating plate:	Yes	No	Inspection badge:		
Last inspection:			Next inspection:		
Short statistics created:					

Remark	Inspector's name and company
Repeat inspection has been performed. – No´) – faults identified – see Inspection report´) Sheet no. _____	_____ (Date Signature)
Repeat inspection has been performed. – No´) – faults identified – see Inspection report´) Sheet no. _____	_____ (Date Signature)
Repeat inspection has been performed. – No´) – faults identified – see Inspection report´) Sheet no. _____	_____ (Date Signature)
Repeat inspection has been performed. – No´) – faults identified – see Inspection report´) Sheet no. _____	_____ (Date Signature)
Repeat inspection has been performed. – No´) – faults identified – see Inspection report´) Sheet no. _____	_____ (Date Signature)
Repeat inspection has been performed. – No´) – faults identified – see Inspection report´) Sheet no. _____	_____ (Date Signature)
´) please delete if not applicable	

13. Disassembly and Disposal

As manufacturers, we are required by law to inform you not to dispose of the product as unsorted waste. Dispose of it separately via collection and return points for industrial and commercial waste. The product must therefore be disassembled into its individual components.

13.1 Disassembly

CAUTION

Disassembly of the product on unstable surfaces or by means of unsuitable tools may result in injuries.

1. The assembled product is disassembled in the reverse order to that described in Chapter 9.
2. The individual assemblies of the product must then be disassembled by means of a suitable tool.

13.2 Disposal



INFORMATION FOR DISPOSAL

If the product is no longer functional or cannot be repaired, it must be disposed of in accordance with the applicable regulations.

The product consists of several different material components which must be disposed of separately:

1. Dispose of aluminium components as scrap aluminium.
2. Dispose of metal components as scrap metal.
3. Dispose of plastic components as scrap plastic.
4. Dispose of electrical components as electrical scrap (when using an electrical chain hoist).

13.3 Disposal of packaging material



INFORMATION FOR DISPOSAL

Packaging material must be correctly disposed of or recycled.

14. Service

14.1 Contact

For service matters or all other enquiries, please contact your supplier.

14.2 Spare parts ordering or reordering process



INFO

Please use the overview and table in Chapter 8 for better identification of the required component and submit this to your supplier.

1. Determine the serial number of your product. The serial number can be found in this user information in Chapter 3. The serial number is also engraved on the product.
2. Determine the year of manufacture of the product. The year of manufacture can be found in this user information in Chapter 3. The year of manufacture is also engraved on the product.
3. Use the overview in Chapter 8 and highlight the component or assembly in question.
4. Then contact your supplier directly, submitting the collected data and any other details.