

Instruction Manual
for AC Generators
English

QAX 12-20-24-30-35 Dd

QAX 12-20-24-30-35 Dd

Instruction Manual for AC Generators

Instruction manual	5
Circuit diagrams	83

Original instructions

Printed matter N°
2954 3490 02
06/2010



ATLAS COPCO - PORTABLE AIR DIVISION
www.atlascopco.com

Warranty and Liability Limitation

Use only authorized parts.

Any damage or malfunction caused by the use of unauthorized parts is not covered by Warranty or Product Liability.

The manufacturer does not accept any liability for any damage arising from modifications, additions or conversions made without the manufacturer's approval in writing.

Neglecting maintenance or making changes to the setup of the machine can result in major hazards, including fire risk.

While every effort has been made to ensure that the information in this manual is correct, Atlas Copco does not assume responsibility for possible errors.

Copyright 2010, Atlas Copco Airpower n.v., Antwerp, Belgium.

Any unauthorized use or copying of the contents or any part thereof is prohibited.

This applies in particular to trademarks, model denominations, part numbers and drawings.



Congratulations on the purchase of your AC generator. It is a solid, safe and reliable machine, built according to the latest technology. Follow the instructions in this booklet and we guarantee you years of troublefree operation. Please read the following instructions carefully before starting to use your machine.

While every effort has been made to ensure that the information in this manual is correct, Atlas Copco does not assume responsibility for possible errors. Atlas Copco reserves the right to make changes without prior notice.

Contents

Safety precautions for portable generators	6	Preventive maintenance schedule for the generator.....	33	Description of the mechanical options .	45
Leading particulars	13	Engine maintenance.....	33	Technical specifications	55
Main parts Metal Canopy and Hardhat units	13	(*) Measuring the alternator insulation resistance.....	33	Technical specifications for QAX 12 Dd.....	55
General description	15	Engine fuel specifications.....	33	Technical specifications for QAX 20 Dd.....	60
Markings.....	16	Engine oil specifications	33	Technical specifications for QAX 24 Dd.....	65
Drain plugs.....	16	Adjustments & service procedures.....	35	Technical specifications for QAX 30 Dd.....	70
Control and indicator panel Qc1002™..	17	Storage of the generator	38	Technical specifications for QAX 35 Dd.....	75
Outlet sockets (S).....	25	Storage	38	Torque values	80
Terminal board for QAX 24-35 Dd	27	Preparing for operation after storage ...	38	Conversion list of SI units into British units	80
Spillage free	27	Checks and trouble shooting	39	Dataplate	81
Lifting beam	27	Checking voltmeter P4	39	Disposal	82
Operating instructions	28	Checking ammeter P1	39		
Installation.....	28	Alternator troubleshooting	40		
Connecting the generator	28	Engine trouble shooting.....	41		
Before starting	29	Options available for QAX 12-20-24-30-35 Dd units	43		
Operating Qc1002™	30	Circuit diagrams	43		
Maintenance	31	Overview of the electrical options.....	43		
Maintenance schedule	31	Description of the electrical options	43		
Use of service paks.....	33	Overview of the mechanical options	45		

Safety precautions for portable generators

To be read attentively and acted accordingly before towing, lifting, operating, performing maintenance or repairing the generator.

Introduction

The policy of Atlas Copco is to provide the users of their equipment with safe, reliable and efficient products. Factors taken into account are among others:

- the intended and predictable future use of the products, and the environments in which they are expected to operate,
- applicable rules, codes and regulations,
- the expected useful product life, assuming proper service and maintenance,
- providing the manual with up-to-date information.

Before handling any product, take time to read the relevant instruction manual. Besides giving detailed operating instructions, it also gives specific information about safety, preventive maintenance, etc.

Keep the manual always at the unit location, easy accessible to the operating personnel.

See also the safety precautions of the engine and possible other equipment, which are separately sent along or are mentioned on the equipment or parts of the unit.

These safety precautions are general and some statements will therefore not always apply to a particular unit.

Only people that have the right skills should be allowed to operate, adjust, perform maintenance or repair on Atlas Copco equipment. It is the responsibility of management to appoint operators with the appropriate training and skill for each category of job.

Skill level 1: Operator

An operator is trained in all aspects of operating the unit with the push-buttons, and is trained to know the safety aspects.

Skill level 2: Mechanical technician

A mechanical technician is trained to operate the unit the same as the operator. In addition, the mechanical technician is also trained to perform maintenance and repair, as described in the instruction manual, and is allowed to change settings of the control and safety system. A mechanical technician does not work on live electrical components.

Skill level 3: Electrical technician

An electrical technician is trained and has the same qualifications as both the operator and the mechanical technician. In addition, the electrical technician may carry out electrical repairs within the various enclosures of the unit. This includes work on live electrical components.

Skill level 4: Specialist from the manufacturer

This is a skilled specialist sent by the manufacturer or its agent to perform complex repairs or modifications to the equipment.

In general it is recommended that not more than two people operate the unit, more operators could lead to unsafe operating conditions. Take necessary steps to keep unauthorized persons away from the unit and eliminate all possible sources of danger at the unit.

When handling, operating, overhauling and/or performing maintenance or repair on Atlas Copco equipment, the mechanics are expected to use safe engineering practices and to observe all relevant local safety requirements and ordinances. The following list is a reminder of special safety directives and precautions mainly applicable to Atlas Copco equipment.

Neglecting the safety precautions may endanger people as well as environment and machinery:

- endanger people due to electrical, mechanical or chemical influences,
- endanger the environment due to leakage of oil, solvents or other substances,
- endanger the machinery due to function failures.

All responsibility for any damage or injury resulting from neglecting these precautions or by non-observance of ordinary caution and due care required in handling, operating, maintenance or repair, also if not expressly mentioned in this instruction manual, is disclaimed by Atlas Copco.

The manufacturer does not accept any liability for any damage arising from the use of non-original parts and for modifications, additions or conversions made without the manufacturer's approval in writing.

If any statement in this manual does not comply with local legislation, the stricter of the two shall be applied.

Statements in these safety precautions should not be interpreted as suggestions, recommendations or inducements that it should be used in violation of any applicable laws or regulations.

General safety precautions

- 1 The owner is responsible for maintaining the unit in a safe operating condition. Unit parts and accessories must be replaced if missing or unsuitable for safe operation.
- 2 The supervisor, or the responsible person, shall at all times make sure that all instructions regarding machinery and equipment operation and maintenance are strictly followed and that the machines with all accessories and safety devices, as well as the consuming devices, are in good repair, free of abnormal wear or abuse, and are not tampered with.
- 3 Whenever there is an indication or any suspicion that an internal part of a machine is overheated, the machine shall be stopped but no inspection covers shall be opened before sufficient cooling time has elapsed; this to avoid the risk of spontaneous ignition of oil vapour when air is admitted.

- 4 Normal ratings (pressures, temperatures, speeds, etc.) shall be durably marked.
- 5 Operate the unit only for the intended purpose and within its rated limits (pressure, temperature, speeds, etc.).
- 6 The machinery and equipment shall be kept clean, i.e. as free as possible from oil, dust or other deposits.
- 7 To prevent an increase in working temperature, inspect and clean heat transfer surfaces (cooler fins, intercoolers, coolant jackets, etc.) regularly. See the maintenance schedule.
- 8 All regulating and safety devices shall be maintained with due care to ensure that they function properly. They may not be put out of action.
- 9 Pressure and temperature gauges shall be checked regularly with regard to their accuracy. They shall be replaced whenever outside acceptable tolerances.
- 10 Safety devices shall be tested as described in the maintenance schedule of the instruction manual to determine that they are in good operating condition.
- 11 Mind the markings and information labels on the unit.
- 12 In the event the safety labels are damaged or destroyed, they must be replaced to ensure operator safety.
- 13 Keep the work area neat. Lack of order will increase the risk of accidents.

- 14 When working on the unit, wear safety clothing. Depending on the kind of activities these are: safety glasses, ear protection, safety helmet (including visor), safety gloves, protective clothing, safety shoes. Do not wear the hair long and loose (protect long hair with a hairnet), or wear loose clothing or jewellery.
- 15 Take precautions against fire. Handle fuel, oil and anti-freeze with care because they are inflammable substances. Do not smoke or approach with naked flame when handling such substances. Keep a fire-extinguisher in the vicinity.

16a Portable generators (with earthing pin):

Earth the generator as well as the load properly.

16b Portable generators IT:

Note: This generator is built to supply a sheer alternating current IT network.
Earth the load properly.

Safety during transport and installation

To lift a unit, all loose or pivoting parts, e.g. doors and towbar, shall first be securely fastened.

Do not attach cables, chains or ropes directly to the lifting eye; apply a crane hook or lifting shackle meeting local safety regulations. Never allow sharp bends in lifting cables, chains or ropes.

Helicopter lifting is not allowed.

It is strictly forbidden to dwell or stay in the risk zone under a lifted load. Never lift the unit over people or residential areas. Lifting acceleration and retardation shall be kept within safe limits.

- 1 Before towing the unit:
 - check the towbar, the brake system and the towing eye. Also check the coupling of the towing vehicle,
 - check the towing and brake capability of the towing vehicle,
 - check that the towbar, jockey wheel or stand leg is safely locked in the raised position,
 - ascertain that the towing eye can swivel freely on the hook,
 - check that the wheels are secure and that the tyres are in good condition and inflated correctly,
 - connect the signalisation cable, check all lights and connect the pneumatic brake couplers,
 - attach the safety break-away cable or safety chain to the towing vehicle,
 - remove wheel chocks, if applied, and disengage the parking brake.

- 2 To tow a unit use a towing vehicle of ample capacity. Refer to the documentation of the towing vehicle.
- 3 If the unit is to be backed up by the towing vehicle, disengage the overrun brake mechanism (if it is not an automatic mechanism).
- 4 Never exceed the maximum towing speed of the unit (mind the local regulations).
- 5 Place the unit on level ground and apply the parking brake before disconnecting the unit from the towing vehicle. Unclip the safety break-away cable or safety chain. If the unit has no parking brake or jockey wheel, immobilize the unit by placing chocks in front of and/or behind the wheels. When the towbar can be positioned vertically, the locking device must be applied and kept in good order.
- 6 To lift heavy parts, a hoist of ample capacity, tested and approved according to local safety regulations, shall be used.
- 7 Lifting hooks, eyes, shackles, etc., shall never be bent and shall only have stress in line with their design load axis. The capacity of a lifting device diminishes when the lifting force is applied at an angle to its load axis.
- 8 For maximum safety and efficiency of the lifting apparatus all lifting members shall be applied as near to perpendicular as possible. If required, a lifting beam shall be applied between hoist and load.
- 9 Never leave a load hanging on a hoist.
- 10 A hoist has to be installed in such a way that the object will be lifted perpendicular. If that is not possible, the necessary precautions must be taken to prevent load-swinging, e.g. by using two hoists, each at approximately the same angle not exceeding 30° from the vertical.
- 11 Locate the unit away from walls. Take all precautions to ensure that hot air exhausted from the engine and driven machine cooling systems cannot be recirculated. If such hot air is taken in by the engine or driven machine cooling fan, this may cause overheating of the unit; if taken in for combustion, the engine power will be reduced.
- 12 Generators shall be stalled on an even, solid floor, in a clean location with sufficient ventilation. If the floor is not level or can vary in inclination, consult Atlas Copco.
- 13 The electrical connections shall correspond to local codes. The machines shall be earthed and protected against short circuits by fuses or circuit breakers.
- 14 Never connect the generator outlets to an installation which is also connected to a public mains.
- 15 Before connecting a load, switch off the corresponding circuit breaker, and check whether frequency, voltage, current and power factor comply with the ratings of the generator.
- 16 Before transportation of the unit, switch off all the circuit breakers.

Safety during use and operation

- 1 When the unit has to operate in a fire-hazardous environment, each engine exhaust has to be provided with a spark arrestor to trap incendiary sparks.
- 2 The exhaust contains carbon monoxide which is a lethal gas. When the unit is used in a confined space, conduct the engine exhaust to the outside atmosphere by a pipe of sufficient diameter; do this in such a way that no extra back pressure is created for the engine. If necessary, install an extractor. Observe any existing local regulations.

Make sure that the unit has sufficient air intake for operation. If necessary, install extra air intake ducts.
- 3 When operating in a dust-laden atmosphere, place the unit so that dust is not carried towards it by the wind. Operation in clean surroundings considerably extends the intervals for cleaning the air intake filters and the cores of the coolers.
- 4 Never remove a filler cap of the coolant system of a hot engine. Wait until the engine has sufficiently cooled down.
- 5 Never refill fuel while the unit is running, unless otherwise stated in the Atlas Copco Instruction Book (AIB). Keep fuel away from hot parts such as air outlet pipes or the engine exhaust. Do not smoke when fuelling. When fuelling from an automatic pump, an earthing cable should be connected to the unit to discharge static electricity. Never spill nor leave oil, fuel, coolant or cleansing agent in or around the unit.

- 6 All doors shall be shut during operation so as not to disturb the cooling air flow inside the bodywork and/or render the silencing less effective. A door should be kept open for a short period only e.g. for inspection or adjustment.
- 7 Periodically carry out maintenance works according to the maintenance schedule.
- 8 Stationary housing guards are provided on all rotating or reciprocating parts not otherwise protected and which may be hazardous to personnel. Machinery shall never be put into operation, when such guards have been removed, before the guards are securely reinstalled.
- 9 Noise, even at reasonable levels, can cause irritation and disturbance which, over a long period of time, may cause severe injuries to the nervous system of human beings.

When the sound pressure level, at any point where personnel normally has to attend, is:
 - below 70 dB(A): no action needs to be taken,
 - above 70 dB(A): noise-protective devices should be provided for people continuously being present in the room,
 - below 85 dB(A): no action needs to be taken for occasional visitors staying a limited time only,
 - above 85 dB(A): room to be classified as a noise-hazardous area and an obvious warning shall be placed permanently at each entrance to alert people entering the room, for even relatively short times, about the need to wear ear protectors,

- above 95 dB(A): the warning(s) at the entrance(s) shall be completed with the recommendation that also occasional visitors shall wear ear protectors,
 - above 105 dB(A): special ear protectors that are adequate for this noise level and the spectral composition of the noise shall be provided and a special warning to that effect shall be placed at each entrance.
- 10 Insulation or safety guards of parts the temperature of which can be in excess of 80°C (175°F) and which may be accidentally touched by personnel shall not be removed before the parts have cooled to room temperature.
 - 11 Never operate the unit in surroundings where there is a possibility of taking in flammable or toxic fumes.
 - 12 If the working process produces fumes, dust or vibration hazards, etc., take the necessary steps to eliminate the risk of personnel injury.
 - 13 When using compressed air or inert gas to clean down equipment, do so with caution and use the appropriate protection, at least safety glasses, for the operator as well as for any bystander. Do not apply compressed air or inert gas to your skin or direct an air or gas stream at people. Never use it to clean dirt from your clothes.
 - 14 When washing parts in or with a cleaning solvent, provide the required ventilation and use appropriate protection such as a breathing filter, safety glasses, rubber apron and gloves, etc.

- 15 Safety shoes should be compulsory in any workshop and if there is a risk, however small, of falling objects, wearing of a safety helmet should be included.
- 16 If there is a risk of inhaling hazardous gases, fumes or dust, the respiratory organs must be protected and depending on the nature of the hazard, so must the eyes and skin.
- 17 Remember that where there is visible dust, the finer, invisible particles will almost certainly be present too; but the fact that no dust can be seen is not a reliable indication that dangerous, invisible dust is not present in the air.
- 18 Never operate the generator in excess of its limits as indicated in the technical specifications and avoid long no-load sequences.
- 19 Never operate the generator in a humid atmosphere. Excessive moisture causes worsening of the generator insulation.
- 20 Do not open electrical cabinets, cubicles or other equipment while voltage is supplied. If such cannot be avoided, e.g. for measurements, tests or adjustments, have the action carried out by a qualified electrician only, with appropriate tools, and ascertain that the required bodily protection against electrical hazards is applied.
- 21 Never touch the power terminals during operation of the machine.
- 22 Whenever an abnormal condition arises, e.g. excessive vibration, noise, odour, etc., switch the circuit breakers to OFF and stop the engine. Correct the faulty condition before restarting.
- 23 Check the electric cables regularly. Damaged cables and insufficient tightening of connections may cause electric shocks. Whenever damaged wires or dangerous conditions are observed, switch the circuit breakers to OFF and stop the engine. Replace the damaged wires or correct the dangerous condition before restarting. Make sure that all electric connections are securely tightened.
- 24 Avoid overloading the generator. The generator is provided with circuit breakers for overload protection. When a breaker has tripped, reduce the concerned load before restarting.
- 25 If the generator is used as stand-by for the mains supply, it must not be operated without control system which automatically disconnects the generator from the mains when the mains supply is restored.
- 26 Never remove the cover of the output terminals during operation. Before connecting or disconnecting wires, switch off the load and the circuit breakers, stop the machine and make sure that the machine cannot be started inadvertently or there is any residual voltage on the power circuit.
- 27 Running the generator at low load for long periods will reduce the lifetime of the engine.

Safety during maintenance and repair

Maintenance, overhaul and repair work shall only be carried out by adequately trained personnel; if required, under supervision of someone qualified for the job.

- 1 Use only the correct tools for maintenance and repair work, and only tools which are in good condition.
- 2 Parts shall only be replaced by genuine Atlas Copco replacement parts.
- 3 All maintenance work, other than routine attention, shall only be undertaken when the unit is stopped. Steps shall be taken to prevent inadvertent starting. In addition, a warning sign bearing a legend such as “work in progress; do not start” shall be attached to the starting equipment.
On engine-driven units the battery shall be disconnected and removed or the terminals covered by insulating caps.
On electrically driven units the main switch shall be locked in open position and the fuses shall be taken out. A warning sign bearing a legend such as “work in progress; do not supply voltage” shall be attached to the fuse box or main switch.
- 4 Prior to stripping an engine or other machine or undertaking major overhaul on it, prevent all movable parts from rolling over or moving.

- 5 Make sure that no tools, loose parts or rags are left in or on the machine. Never leave rags or loose clothing near the engine air intake.
- 6 Never use flammable solvents for cleaning (fire-risk).
- 7 Take safety precautions against toxic vapours of cleaning liquids.
- 8 Never use machine parts as a climbing aid.
- 9 Observe scrupulous cleanliness during maintenance and repair. Keep away dirt, cover the parts and exposed openings with a clean cloth, paper or tape.
- 10 Never weld on or perform any operation involving heat near the fuel or oil systems. Fuel and oil tanks must be completely purged, e.g. by steam-cleaning, before carrying out such operations. Never weld on, or in any way modify, pressure vessels. Disconnect the alternator cables during arc welding on the unit.
- 11 Support the towbar and the axle(s) securely if working underneath the unit or when removing a wheel. Do not rely on jacks.
- 12 Do not remove any of, or tamper with, the sound-damping material. Keep the material free of dirt and liquids such as fuel, oil and cleansing agents. If any sound-damping material is damaged, replace it to prevent the sound pressure level from increasing.
- 13 Use only lubricating oils and greases recommended or approved by Atlas Copco or the machine manufacturer. Ascertain that the selected lubricants comply with all applicable safety regulations, especially with regard to explosion or fire-risk and the possibility of decomposition or generation of hazardous gases. Never mix synthetic with mineral oil.
- 14 Protect the engine, alternator, air intake filter, electrical and regulating components, etc., to prevent moisture ingress, e.g. when steam-cleaning.
- 15 When performing any operation involving heat, flames or sparks on a machine, the surrounding components shall first be screened with non-flammable material.
- 16 Never use a light source with open flame for inspecting the interior of a machine.
- 17 When repair has been completed, the machine shall be barred over at least one revolution for reciprocating machines, several revolutions for rotary ones to ensure that there is no mechanical interference within the machine or driver. Check the direction of rotation of electric motors when starting up the machine initially and after any alteration to the electrical connection(s) or switch gear, to check that the oil pump and the fan function properly.
- 18 Maintenance and repair work should be recorded in an operator's logbook for all machinery. Frequency and nature of repairs can reveal unsafe conditions.
- 19 When hot parts have to be handled, e.g. shrink fitting, special heat-resistant gloves shall be used and, if required, other body protection shall be applied.
- 20 When using cartridge type breathing filter equipment, ascertain that the correct type of cartridge is used and that its useful service life is not surpassed.
- 21 Make sure that oil, solvents and other substances likely to pollute the environment are properly disposed of.
- 22 Before clearing the generator for use after maintenance or overhaul, submit it to a testrun, check that the AC power performance is correct and that the control and shutdown devices function correctly.

Tool applications safety

Apply the proper tool for each job. With the knowledge of correct tool use and knowing the limitations of tools, along with some common sense, many accidents can be prevented.

Special service tools are available for specific jobs and should be used when recommended. The use of these tools will save time and prevent damage to parts.

Battery safety precautions

Batteries

When servicing batteries, always wear protecting clothing and glasses.

- 1 The electrolyte in batteries is a sulphuric acid solution which is fatal if it hits your eyes, and which can cause burns if it contacts your skin. Therefore, be careful when handling batteries, e.g. when checking the charge condition.
- 2 Install a sign prohibiting fire, open flame and smoking at the post where batteries are being charged.
- 3 When batteries are being charged, an explosive gas mixture forms in the cells and might escape through the vent holes in the plugs.
Thus an explosive atmosphere may form around the battery if ventilation is poor, and can remain in and around the battery for several hours after it has been charged. Therefore:
 - never smoke near batteries being, or having recently been, charged,
 - never break live circuits at battery terminals, because a spark usually occurs.

- 4 When connecting an auxiliary battery (AB) in parallel to the unit battery (CB) with booster cables: connect the + pole of AB to the + pole of CB, then connect the - pole of CB to the mass of the unit. Disconnect in the reverse order.

Leading particulars

Main parts Metal Canopy and Hardhat units

The QAX 12-20-24-30-35 Dd is an AC generator, built for continuous running at sites where no electricity is available. The QAX 12 Dd operates at 50 Hz and 230 V - 1 ph or 400 V - 3 ph. The QAX 20-30 Dd operates at 50 Hz and 400 V - 3 ph. The QAX 24-35 Dd operates at 60 Hz and 240 V - 3 ph. The QAX 12-20-24-30-35 Dd generator is driven by an oil-cooled diesel engine, manufactured by DEUTZ. An overview of the main parts is given in the diagram below.

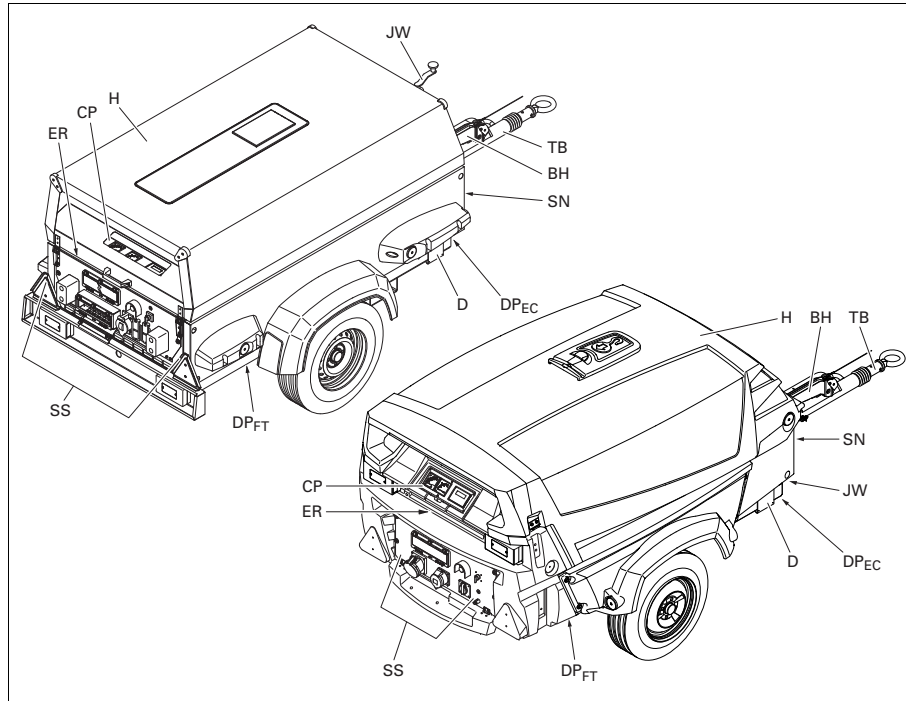

BH	Brake handle
CP	Control panel
D	Data plate
DPEC	Drain plug engine oil cooler
DPFT	Drain plug fuel tank
ER	Earthing rod
H	Hood
JW	Jockey wheel
SN	Serial number
SS	Sockets and safeties
TB	Towbar

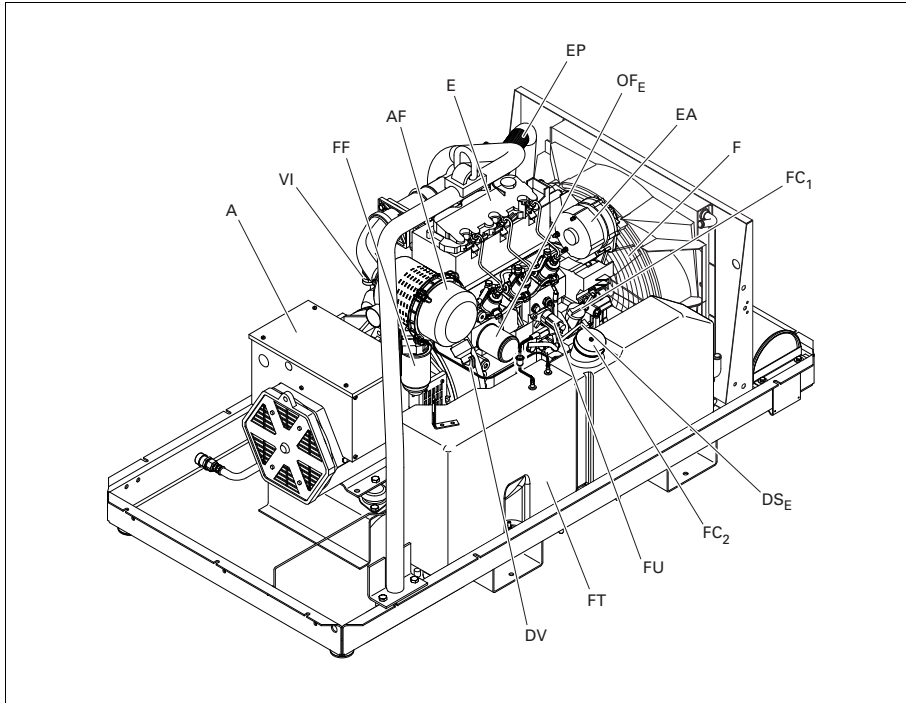

- | | |
|-----|---------------------------|
| A | Alternator |
| AF | Air filter |
| DSE | Engine oil level dipstick |
| DV | Dust evacuation |
| E | Engine |
| EA | Alternator |
| EP | Exhaust pipe |
| F | Fan |
| FC1 | Filler cap (engine oil) |
| FC2 | Filler cap (fuel tank) |
| FF | Fuel filter |
| FT | Fuel tank |
| FU | Fuel pump |
| OFE | Oil filter (engine) |
| VI | Vacuum indicator |

General description

Engine

The alternator is driven by an oil-cooled diesel engine. The engine's power is transmitted through a direct disc coupling.

Alternator

The generator houses a single bearing alternator with a dedicated voltage regulator.

The synchronous brushless alternator has Class H rotor and stator windings in an IP23 housing.

Cooling system

The engine is provided with an oil cooler. The cooling air is generated by a fan, driven by the engine.

Safety devices

The engine is equipped with low oil pressure and high oil temperature shut-down switches.

Frame and axle

The generator/engine unit is supported by rubber buffers in the frame.

As an option the unit can be equipped with an adjustable or fixed towbar, an overrun and parking brake and towing eyes type AC, DIN, ball, GB, IT, NATO (for options see "Undercarriage (axle, towbar, towing eyes)" on page 45).

The braking system consists of an integrated parking brake and overrunbrake. When driving backwards the overrunbrake is not engaged automatically.

Lifting eye

A lifting eye is accessible when the small door at the top of the unit is unlocked.

Control panel

The control panel grouping volt and amp gauge, control switch etc., is placed in the center at the rear end.

Data plate

The generator is furnished with a data plate showing the product code, the unit number and the power output (see "Dataplate" on page 81).

Serial number

The serial number is located on the right-hand front side of the frame.

Bodywork

The bodywork has openings at the shaped front and rear end for the intake and outlet of cooling air and a hood for maintenance and service operations.

The alternator, the engine, the cooling system, etc. are enclosed in a sound-insulated bodywork that can be opened at the rear end by means of stirrups.

To be able to lift the QAX 12-20-24-30-35 Dd by means of a forklift, rectangular holes are provided in the frame.

The earthing rod, to be connected to the generator's earth terminal is located inside the generator.

Markings

A brief description of all markings provided on the generator is given hereafter.



Instruction book label.



Indicates that the engine exhaust is a hot and harmful gas, which is toxic in case of inhalation. Always make sure that the unit is operated outside or in a well-ventilated room.



Indicates that these parts can become very hot during operation (e.g. engine, cooler, etc.). Always make sure that these parts are cooled down before touching them.



Indicates that the lifting eye may NOT be used to lift the generator. Applies when genset is mounted on a lighting tower.



Indicates the lifting eye of the generator.



Indicates that the generator may be refuelled with diesel fuel only.



Indicates the drain for the engine oil.



Indicates the drain plug for the engine fuel.



Indicates the drain for the coolant + drain frame.



Use PAROIL E only.



Indicates the different earthing connections on the generator.



Indicates that the alternator should not be cleaned with high pressurised water.



Indicates that the unit may start automatically and that the instruction book has to be consulted prior to use.



Read the instruction manual before using the lifting eye.

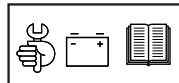

Read the instruction manual before working on the battery.



Do not open the hood when genset is running.

Atlas Copco		GAX 12, GAX 2024, GAX 3035	
Service Pack	500 h	Yearly (max. 1000h)	
GAX 12	XXXX XXXX XX	XXXX XXXX XX	
GAX 2024	XXXX XXXX XX	XXXX XXXX XX	
GAX 3035	XXXX XXXX XX	XXXX XXXX XX	
Engine oil		PAROIL E	PAROIL Extra
5 l	XXXX XXXX XX	XXXX XXXX XX	
20 l	XXXX XXXX XX	XXXX XXXX XX	
200 l	XXXX XXXX XX	XXXX XXXX XX	
1000 l	XXXX XXXX XX	XXXX XXXX XX	

Indicates the partnumbers of the different service packs and of the engine oil.

These parts can be ordered to the factory.

Drain plugs

The drain holes for the engine oil and the plug for the fuel, are located and labelled on the frame; the fuel drain plug at the front, the others at the service side.

The drain flexible for engine oil is brought to the outside of the generator through the drain hole.

Control and indicator panel Qc1002™

General description Qc1002™ control panel

The control and indicator panel is located on a panel at the back of the unit. This panel allows easy access to the parts mounted behind it.

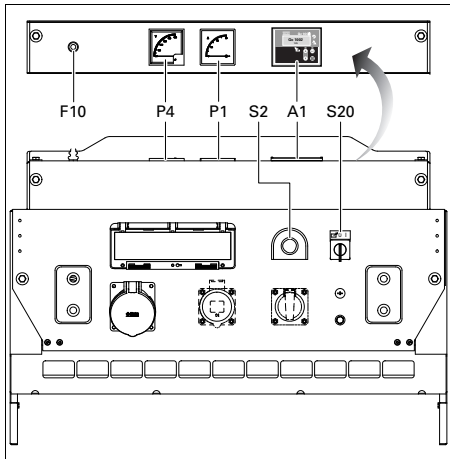

A1 Qc1002™ display

F10 Fuse

The fuse activates when the current from the battery to the engine control circuit exceeds its setting. The fuse can be reset by pushing the button.

S2 Emergency stop button

Push the button to stop the generator in case of an emergency. When the button is pressed, it must be unlocked, by turning it anti-clockwise, before the generator can be restarted.

S20 Remote/ON/OFF switch

To start up the unit (locally or remote).

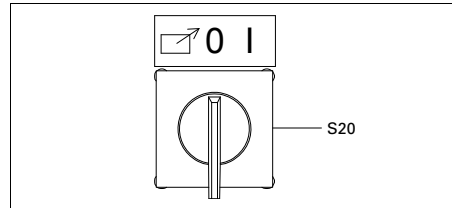

Remote start connections

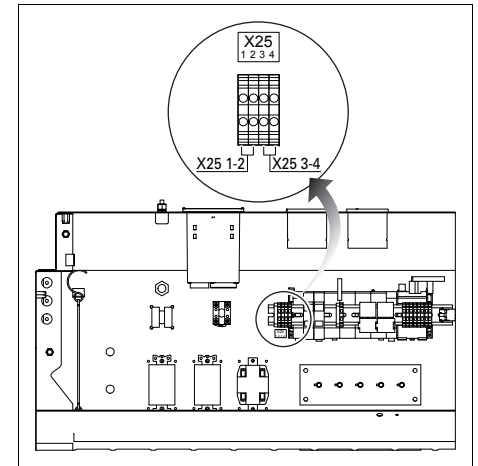

X25 1-2 Remote start signal input

X25 3-4 Plant contactor output



Refer to the circuit diagrams for the correct connection.

Generator gauges

P1..... Ampmeter

Indicates the outgoing current in the first phase (L1)

P4..... Voltmeter

Indicates the voltage between L2 and L3.

Qc1002™ Module

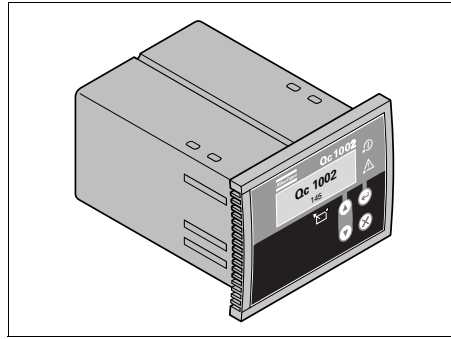

The Qc1002™ module is located inside the control panel. This control module will carry out all necessary tasks to control and protect a generator, regardless of the use of the generator.

This means that the Qc1002™ module can be used for several applications.

Pushbutton and LED functions

Following pushbuttons are used on the Qc1002™



ENTER: Is used to select and confirm changed settings in the Parameter list.



UP: Is used to scroll through the display information and to adjust parameter value upwards.



DOWN: Is used to scroll through the display information and to adjust parameter value downwards.



BACK: Is used to leave/enter the Alarm pop-up window, to leave the Parameter list and to leave menu's without change.

Following LEDs are used on the Qc1002™

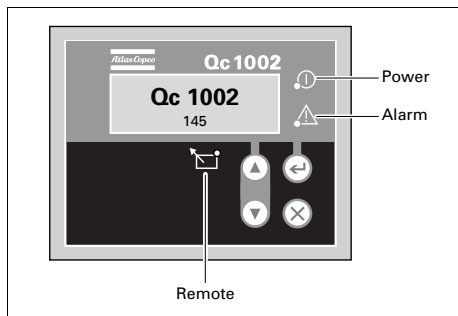

Power	Green LED indicates that the unit is powered up.
Remote	Green LED indicates that the Remote Mode is selected.
Alarm	Flashing red LED indicates that an alarm is present. A continuous red LED indicates that the alarm has been acknowledged by the user. The exact alarm is shown on the display.

Qc1002™ Menu Overview

At Qc1002™, the LCD will show following information:

- in **Normal** condition (scroll through the information using **UP** and **DOWN**):
 - Controller type & version
 - Parameter list
 - Alarm list
 - LOG list
 - Service Timer 1 & Service Timer 2
 - Battery Voltage
 - Voltage - frequency - running hours
- in **Alarm** condition (scroll through the information using **UP** and **DOWN**):
 - a list of all active Alarms

It's possible to scroll through the views, using the **UP** and **DOWN** buttons. The scrolling is continuous.

If a Special status comes up, the Status Display is shown.

If an Alarm comes up, the Alarm Display is shown.

Controller type and version display



This view shows the controller type and the ASW version number.

Parameter display

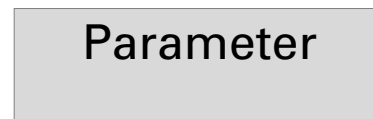

This view shows a number of Parameter settings and gives access to them.

An overview is given in "Parameter list" on page 21.

Alarm list display

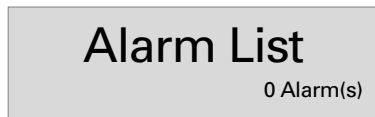

This view shows the number of active alarms and gives access to them.

An overview is given in “Alarm Display (pop-up window)” on page 23.

LOG list display

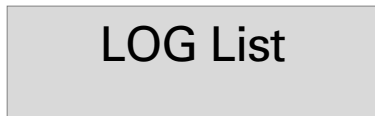

This view shows the alarm memory and gives access to it.

An overview is given in “LOG list” on page 24.

Service timer 1 & Service timer 2 display

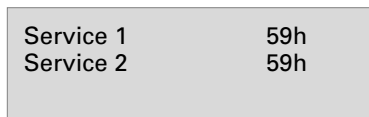

This view shows both Service timers. The service timer indication is shown when service time has run out. It can be removed by resetting the timers or acknowledging the Service timer indication.

The service timer indications count and give an alarm when value is reached.

Resetting the Service Timers can be done through the Parameter display.

Battery Voltage display

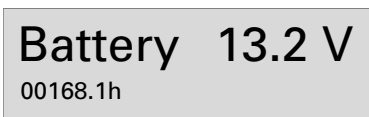

This view shows the Battery voltage and the running hours.

Voltage - frequency - running hours display

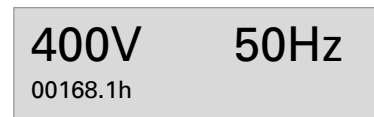

This view shows the voltage, frequency and running hours.

Qc1002™ Menu Description

Status Display (pop-up window)

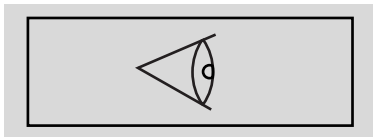

In case special statuses are entered (e.g. diagnostic mode), a pop-up window will automatically be entered for as long as the status is active.

The background screen is not updated when the status pop-up window is active.

If a special status has elapsed, the active view will be entered again automatically.

If an Alarm comes up, the Alarm Display is shown.

Parameter list

The Parameter Menu's are pre-programmed !

A password will be asked for when an attempt to change a setting is about to be done (user password = 2003).

Menu's shown on the Parameter list LCD:

- Running hours adjust

This menu is used to adjust the amount of running hours. The running hours can only be raised, not lowered.

- Unit Type



Unit type 4 for QAX 12-20-24-30-35 Dd !

- Service Timer 2 reset

- Service Timer 1 reset

These menus are used to reset the service timers. When a service timer alarm occurs and is acknowledged, the service timer will be reset automatically.

- Diagnostics Menu

This menu is used to power up the engine electronics without starting the engine. When this setting is switched 'on', electric power will be supplied to the engine electronics after half a minute delay. The unit can not be started as long as this parameter is switched 'on'.

- Unit Menu

This menu is used to select whether temperature and pressure should appear in °C/bar or °F/psi.

- Language selection

Icons is the default factory set language, but 6 other languages can be selected: English, French, German, Italian, Spanish and Cyrillic (Russian). All information in the Parameter List display is always in English.

- Generator Underfrequency: failclass, enable, delay, setpoint

- Generator Overfrequency: failclass, enable, delay, setpoint

- Generator Undervoltage: failclass, enable, delay, setpoint

- Generator Overvoltage: failclass, enable, delay, setpoint

It's possible to scroll between configuration menu's by using the pushbuttons UP and DOWN.

Pushing the ENTER button activates the configuration menu which is shown at the display.

This is the described menu flow for changing the unit type:

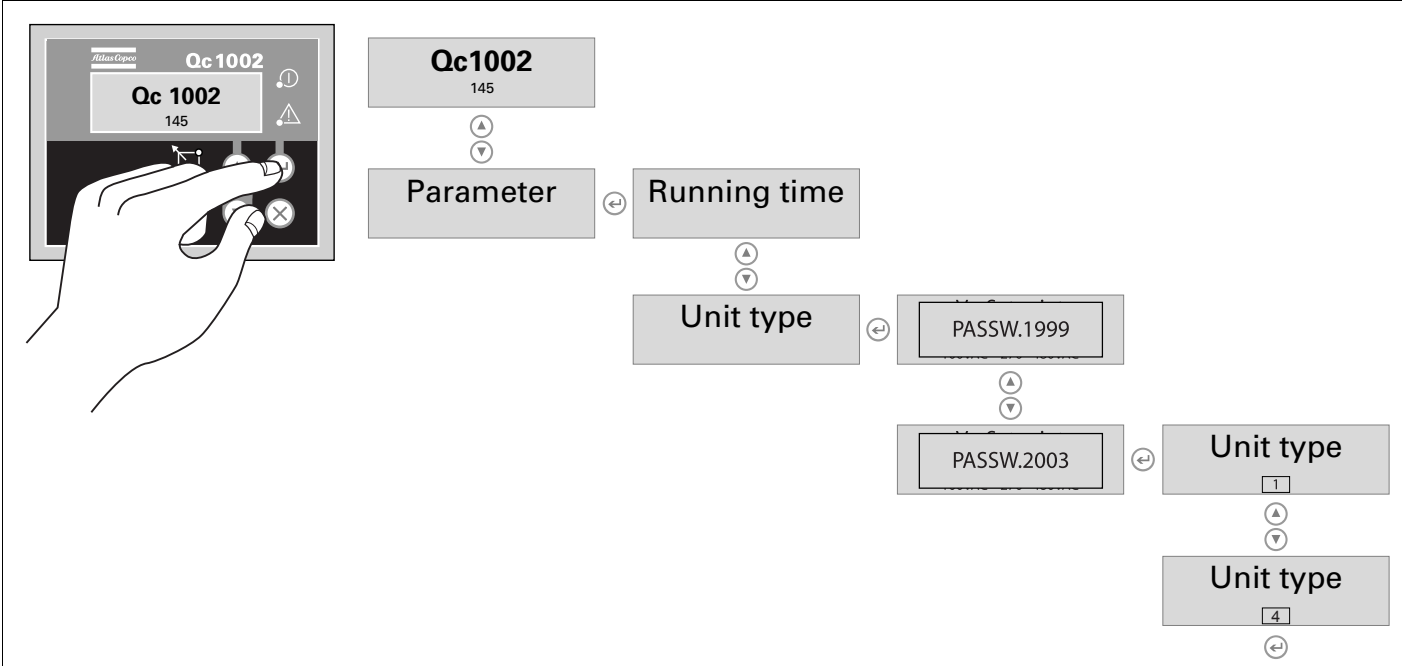

Alarm Display (pop-up window)

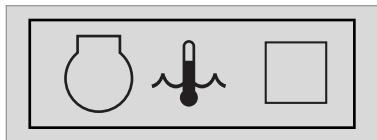

In case an Alarm occurs, a pop-up window will automatically be displayed for as long as the alarm is active, no matter which view is active. The flashing red alarm LED will light up. The alarm icons will be shown together with an acknowledgement check-box. Push the ENTER button to acknowledge the alarm. When the alarm has been acknowledged, a V-marking will appear in the check-box and the red alarm LED will light up continuously.



An alarm should always be acknowledged before solving the problem that causes the alarm.

The Alarm Display can always be left by pushing the BACK button.

If more than one alarm comes up, it's possible to scroll through the alarm messages with the UP and DOWN pushbuttons. The newest alarm will be placed at the bottom of the list (meaning that the older alarm stays at the display when a newer alarm comes up).

If one or more than one alarm is present, an arrow at the right of the display will be shown.

Following general groups of Alarms exist:

- Warning: Alarm LED lights up + Alarm pop-up appears on the display + Alarm relay is empowered (if configured)
- Shutdown: 'Trip of GB' actions + unit stops immediately

List of possible alarms:

LOW OIL PRESSURE



HIGH COOLANT TEMPERATURE



CHARGING ALTERNATOR

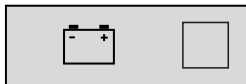

GENERATOR OVERVOLTAGE



GENERATOR UNDER-VOLTAGE



GENERATOR OVER-FREQUENCY

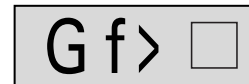

GENERATOR UNDER-FREQUENCY



SERVICE TIMER 1

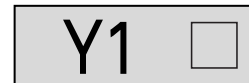

SERVICE TIMER 2

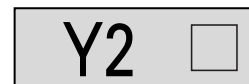

ENGINE ALARM



EMERGENCY
STOP



START FAILURE



STOP FAILURE



LOG list

The unit will keep an event log of the latest 30 events.

Events are:

- shutdowns
- service timer 1/2 reset
- unit type changes

Together with each event, the running hours at the time of the event will be stored.

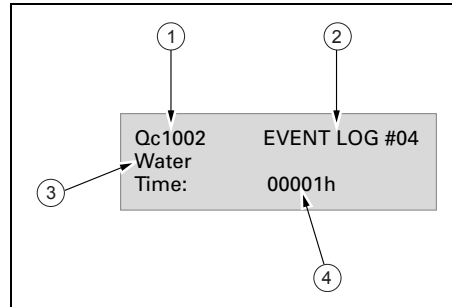

- | | |
|---|-----------------|
| 1 | Controller type |
| 2 | Event number |
| 3 | Event |
| 4 | Running hours |

Remote start operation

Installation wirings:

- X25.1 & X25.2 to be wired for the remote start switch.
- X25.3 & X25.4 to be wired for the remote contactor (open/close).

Fail classes

All the activated alarms of the Qc1002™ have their own pre-defined fail class.

All alarms are enabled according to one of these three statuses:

- disabled alarm, no supervision of alarm (OFF).
- enabled alarm, supervision of alarm all the time (ON).
- running alarm, only supervision when the machine is running (RUN).

Outlet sockets (S)

Outlet sockets for QAX 12 Dd 1-phase units

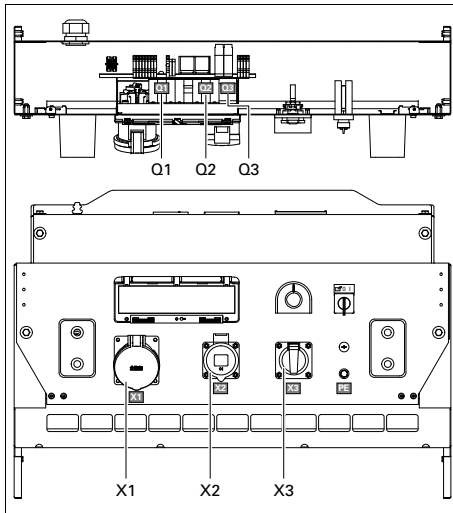

The outlet sockets application provides the following outlet sockets and circuit breakers:

X1..... 1-phase outlet socket (230 V AC)

Provides phases L, neutral and earthing.

X2..... 1-phase outlet socket (230 V AC)

Provides phases L, neutral and earthing.

X3..... 1-phase outlet socket (230 V Y)

Provides phase L, neutral and earthing.

Q1..... Main circuit breaker and minimum voltage relay

Interrupts the power supply to X1 when a short-circuit occurs at the load side or the overcurrent protection (50 A) is activated or when the shunt trip is energized. It must be reset manually after eliminating the problem.

Q2..... Circuit breaker for X2

Interrupts the power supply to X2 when a short-circuit occurs at the load side, or when the overcurrent protection (32 A) is activated. When activated, Q2 interrupts phase L and the neutral towards X2. It can be activated again after eliminating the problem.

Q3..... Circuit breaker for X3

Interrupts the power supply to X3 when a short-circuit occurs at the load side, or when the earth leak detector (30 mA), or when the overcurrent protection (16 A) is activated. When activated, Q3 interrupts phase L and the neutral towards X3. It can be activated again after eliminating the problem.



Circuit breaker Q1 does not only interrupt the power supply towards socket X1 but also towards sockets X2 and X3.

Make sure to switch on circuit breakers Q1, Q2 and Q3 after starting the generator when power supply is done by means of X2 or X3.

Outlet sockets for QAX 12-20-30 Dd 3-phase units

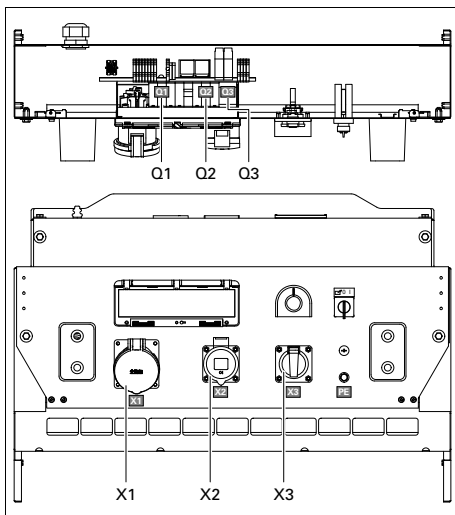

The outlet sockets application provides the following outlet sockets and circuit breakers:

X1 3-phase outlet socket (400 V Y)

Provides phases L1, L2 and L3, neutral and earthing.

X2 3-phase outlet socket (400 V Y)

Provides phases L1, L2 and L3, neutral and earthing.

X3 1-phase outlet socket (230 V Y)

Provides phase L3, neutral and earthing.

Q1 Main circuit breaker and minimum voltage relay

Interrupts the power supply to X1 when a short-circuit occurs at the load side or the overcurrent protection (QAX 12: 20 A, QAX 20: 32 A, QAX 30: 50 A) is activated or when the shunt trip is energized. It must be reset manually after eliminating the problem.

Q2 Circuit breaker for X2

Interrupts the power supply to X2 when a short-circuit occurs at the load side, or when the overcurrent protection (QAX 12-20: 16 A, QAX 30: 16 A/32 A) is activated. When activated, Q2 interrupts the three phases towards X2. It can be activated again after eliminating the problem.

Q3 Circuit breaker for X3

Interrupts the power supply to X3 when a short-circuit occurs at the load side, or when the earth leak detector (30 mA), or when the overcurrent protection (16 A) is activated. When activated, Q3 interrupts phase L3 and the neutral towards X3. It can be activated again after eliminating the problem.



Circuit breaker Q1 does not only interrupt the power supply towards socket X1 but also towards sockets X2 and X3.

Make sure to switch on circuit breakers Q1, Q2 and Q3 after starting the generator when power supply is done by means of X2 or X3.

Terminal board for QAX 24-35 Dd

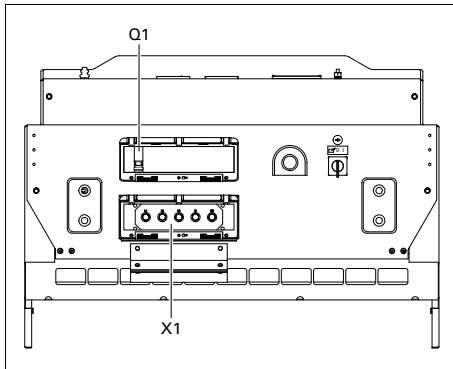

The terminal board application provides following circuit breaker:

X1.....Terminal board

Provides a more easy connection of cables.

Q1.....Main circuit breaker and minimum voltage relay

Interrupts the power supply to X1 when a short-circuit occurs at the load side or the overcurrent protection (QAX 24: 63 A, QAX 35: 100 A) is activated or when the shunt trip is energized. It must be reset manually after eliminating the problem.

Spillage free

With spillage free, it is possible to drain the frame using the drain plugs.

Lifting beam

Lifting instruction generator

When lifting the generator, the hoist has to be placed in such a way that the generator, which must be placed level, will be lifted vertically. Keep lifting acceleration and retardation within safe limits.

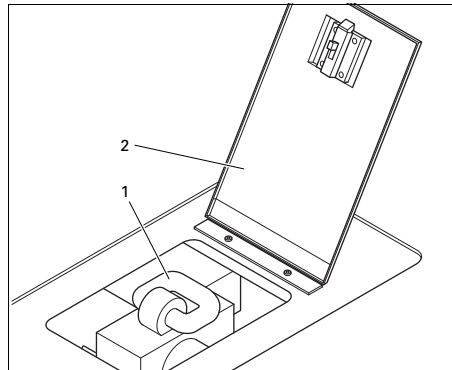

- 1 | Lifting eye
- 2 | Small door

Preferably use the lifting eye (1) after opening the small door (2).



Lifting acceleration and retardation must be kept within safe limits (max. 2 g).

Helicopter lifting is not allowed.

Certain engine maintenance might require to remove the lifting beam, for example when adjusting the engine valves. When reinstalling the lifting beam it is required to torque the bolts with a value of 40 Nm \pm 10.

Lifting instruction for generators mounted on a lighting tower



When the genset is mounted on a lighting tower it is NOT permitted to use the lifting eye for lifting of the assembly. Instead use the 4 lifting hooks situated at the corners of the lighting tower undercarriage. Ignoring these instructions may lead to damage and personal injury !

Operating instructions



In your own interest, always strictly observe all relevant safety instructions.

Do not operate the generator in excess of the limitations mentioned in the Technical Specifications.

Local rules concerning the setting up of low voltage power installations (below 1000 V) must be respected when connecting site distribution panels, switch gear or loads to the generator.

At each start-up and at any time a new load is connected, the earthing of the generator must be verified. Earthing must be done either by the earthing rod or, if available, by an existing, suitable earthing installation. The protective system against excessive contact voltage is not effective unless a suitable earthing is made.

The generator is wired for a TN-system to IEC 364-3, i.e. one point in the power source directly earthed - in this case the neutral. The exposed conductive parts of the electric installation must be directly connected to the functional earth.

If operating the generator in another power system, e.g. an IT-system, other protective devices required for these types must be installed. In any case only a qualified electrician is authorized to remove the connection between the neutral (N) and earth terminals in the terminal box of the alternator.

Installation

- Place the generator on a horizontal, even and solid floor.
- The generator should be kept with the doors closed, in order to avoid the ingress of water and dust. Dust ingress reduces the lifetime of filters and may reduce your generator's performance.
- Check that the engine exhaust is not directed towards people. If the generator is operated indoors, install an exhaust pipe of sufficient diameter to duct the engine exhaust towards the outside. Check for sufficient ventilation so that the cooling air is not recirculated. If necessary, consult Atlas Copco.
- Leave enough space for operation, inspection and maintenance (at least 1 meter at each side).
- Check that the inner earthing system is in compliance with the local legislation.
- Check the tightness of the bolts and nuts.

- Install the earthing rod as near as possible to the generator and make sure not to have a contact voltage higher than 25 V .
- Check that the cable end of the earthing rod is connected to the earth terminal.

Connecting the generator

Precautions for non-linear and sensitive loads



Non-linear loads draw currents with high contents in harmonics, causing distortion in the wave form of the voltage generated by the alternator.

The most common non-linear, 3-phase loads are thyristor/rectifier-controlled loads, such as convertors supplying voltage to variable speed motors, uninterruptable power supplies and Telecom supplies. Gas-discharge lighting arranged in single-phase circuits generate high 3rd harmonics and risk for excessive neutral current.

Loads most sensitive to voltage distortion include incandescent lamps, discharge lamps, computers, X-ray equipment, audio amplifiers and elevators.

Consult Atlas Copco for measures against the adverse influence of non-linear loads.

Quality, minimum section and maximum length of cables

The cable connected to the terminal board of the generator must be selected in accordance with local legislation. The type of cable, its rated voltage and current carrying capacity are determined by installation conditions, stress and ambient temperature. For flexible wiring, rubber-sheathed, flexible core conductors of the type H07 RN-F (Cenelec HD.22) or better must be used.

The following table indicates the maximum allowable 3-phase currents (in A), in an ambient temperature of 40°C, for cable types (multiple and single core PVC insulated conductors and H07 RN-F multiple core conductors) and wire sections as listed, in accordance with VDE 0298 installation method C3. Local regulations remain applicable if they are stricter than those proposed below.

Wire section (mm ²)	Max. current (A)		
	Multiple core	Single core	H07 RN-F
2.5	22	25	21
4	30	33	28
6	38	42	36
10	53	57	50
16	71	76	67
25	94	101	88
35	114	123	110
50	138	155	138
70	176	191	170
95	212	228	205

The lowest acceptable wire section and the corresponding maximum cable or conductor length for multiple core cable or H07 RN-F, at rated current (20 A), for a voltage drop e lower than 5% and at a power factor of 0.80, are respectively 2.5 mm² and 144 m. In case electric motors must be started, oversizing the cable is advisable.

The voltage drop across a cable can be determined as follows:

$$e = \frac{\sqrt{3} \cdot I \cdot L \cdot (R \cdot \cos \varphi + X \cdot \sin \varphi)}{1000}$$

e = Voltage drop (V)

I = Rated current (A)

L = Length of conductors (m)

R = Resistance (Ω /km to VDE 0102)

X = Reactance (Ω /km to VDE 0102)

Connecting the load

- Check whether frequency, voltage and current comply with the ratings of the generator.
- Provide for the load cable, without excessive length, and lay it out in a safe way without forming coils.

Before starting

- Before initial start-up, prepare battery for operation if not already done.
- With the generator standing level, check the engine oil level and top up if necessary. The oil level must be near to, but not exceed the high mark on the engine oil level dipstick.
- Check the vacuum indicator of the air filter. If the red part shows completely, replace the filter element.
- Press the vacuator valve of the air filter to remove dust.
- Check the generator for leakage, tightness of wire terminals, etc. Correct if necessary.
- Check that fuse F10 has not tripped and that the emergency stop is in the OUT position.
- Check that the load is switched off.
- Check that circuit breaker Q1 is switched off.

Operating Qc1002™

Starting Qc1002™

To start up the unit locally, proceed as follows:

- Switch on the battery switch.
- Switch off circuit breaker Q1. This is not necessary when a plant contactor is installed between Q1 and the load.
- Put the starter switch S20 in position I.
- The unit will start. The starting attempt will take maximum 12 seconds.
- Switch on circuit breaker Q1 in case no contactor is installed.

To start up the unit from a remote location, proceed as follows:

- Put the starter switch S20 in position  .
- Switch on circuit breaker Q1.
- Put the remote start/stop switch in position start.
- The unit will start. The starting attempt will take maximum 12 seconds.

During operation Qc1002™

Following points should be carried out regularly:

- Check the engine gauges and the lamps for normal readings.



Avoid to let the engine run out of fuel. If it happened, priming will speed up the starting.

- Check for leakage of oil, fuel or coolant.
- Avoid long low-load periods (< 30%). In this case, an output drop and higher oil consumption of the engine could occur.
- Check, by means of the generator gauges, that the voltage between the phases is identical and that the rated current in the first phase (L1) is not exceeded.
- When single-phase loads are connected to the generator output terminals, keep all loads well-balanced (only for QAX - 3 phase).
- If circuit breakers are activated during operation, switch off the load and stop the generator. Check and, if necessary, decrease the load.



The generator's doors may only remain opened for short periods during operation, to carry out checks for example.

Stopping Qc1002™

To stop the unit locally, proceed as follows:

- Switch off the load.
- Switch off circuit breaker Q1.
- Let the engine run for about 5 minutes.
- Stop the engine by putting the starter switch S20 in position O.
- Lock the hood and the door of the indicators and control panel to avoid unauthorized access.

To stop the unit when the starter switch is in position , proceed as follows:

- Switch off the load.
- Stop the engine by putting the remote start/stop switch in position stop or by putting the starter switch S20 in position O.
- Cooldown period default 15 sec.
- Lock the hood and the door of the indicators and control panel to avoid unauthorized access.

Maintenance

Maintenance schedule

 Before carrying out any maintenance activity, check that the start switch is in position O and that no electrical power is present on the terminals.

Maintenance schedule	Daily	Every 500 hours	Every 1000 hours or yearly
Service pak	-	2912 4397 05	2912 4398 06 (QAX 12 Dd) 2912 4399 06 (QAX 20-24-30-35 Dd)
<i>For the most important subassemblies, Atlas Copco has developed service kits that combine all wear parts. These service kits offer you the benefits of genuine parts, save on administration costs and are offered at reduced price, compared to the loose components. Refer to the parts list for more information on the contents of the service kits.</i>			
Check or drain water in fuelfilter/waterseparator	x	x	x
Clean air cleaner and dust bowl	x	x	x
Check vacuum indicator	x	x	x
Visual walk around the unit	x	x	x
Replace engine oil (1)		x	x
Replace engine oil filter (1)		x	x
Check/clean radiator/cooler fins		x	x
Check tension and condition of the V-belt		x	x
Grease hood hinges and locks		x	x
Replace fuel filter element		x	x
Replace fuel prefilter element		x	x
Check electrolyte level and terminals of battery		x	x
Check engine mounts		x	x

Check crankcase ventilation system		x	x
Check condition of cooling fan assembly		x	x
Check engine electrical ground connection		x	x
Replace air filter element (2)		x	x
Monitor Insulation Resistance of the main alternator		x	x
Check tyre pressure		x	x
Check torque of wheel nuts		x	x
Check/adjust brake system (if installed)		x	x
Check joints, connections, couplings of the towbar		x	x
Replace V-belt			x
Replace safety cartridge			x
Check and adjust engine inlet and outlet valves (3)			x
Check alternator and starter motor			x
Check electrical system for security of cables and wear			x
Test thermostats			x
Inspection by Atlas Copco Service technician		Generators in standby application have to be tested on a regular basis. At least once a month the engine should run for minimum 30 minutes at a high load (50% - 70%) that the engine reaches its operating temperature.	



Keep the bolts of the housing, the lifting eye, the towbar and the axle securely tightened. Refer to “Technical specifications” on page 55 and to “Torque values” on page 80.

Notes:

In highly dusty environments, these service intervals do not apply. Check and/or replace filters and clean radiator on a regular basis.

- (1) 500 hrs only valid when using Paroil E. Also drain engine oil from oil cooler.
- (2) Air filter should be replaced sooner when the unit is operating in a dusty environment.
- (3) Not required for units equipped with hydraulic tappets engines (QAX 30 COM2).

Use of service paks

Service Paks include all genuine parts needed for normal maintenance of both generator and engine. Service Paks minimize downtime and keep your maintenance budget low.

The order number of the Service Paks are listed in the Atlas Copco Parts list (ASL). Order Service Paks at your local Atlas Copco dealer.

Preventive maintenance schedule for the generator

The schedule contains a summary of the maintenance instructions. Read the respective section before taking maintenance measures.

When servicing, replace all disengaged packings, e.g. gaskets, O-rings, washers.

For engine maintenance refer to Engine Operation Manual.

The maintenance schedule has to be seen as a guideline for units operating in a dusty environment

typical to generator applications. Maintenance schedule can be adapted depending on application, environment and quality of maintenance.

Engine maintenance

Refer to the engine's operator manual for full maintenance schedule. See also "Technical specifications" on page 55.

(* Measuring the alternator insulation resistance

A 500 V megger is required to measure the alternator insulation resistance.

If the N-terminal is connected to the earthing system, it must be disconnected from the earth terminal. Disconnect the AVR.

Connect the megger between the earth terminal and terminal L1 and generate a voltage of 500 V. The scale must indicate a resistance of at least 1 MΩ.

Refer to the alternator operating and maintenance instructions for more details.

Engine fuel specifications

For fuel specifications, please contact your Atlas Copco Customer Center.

Engine oil specifications



It is strongly recommended to use Atlas Copco branded lubrication oils.

High-quality, mineral, hydraulic or synthesized hydrocarbon oil with rust and oxidation inhibitors, anti-foam and anti-wear properties is recommended. The viscosity grade should correspond to the ambient temperature and ISO 3448, as follows.

Engine	Type of lubricant
between -15°C (5°F) and 40°C (104°F)	PAROIL E
between -25°C (-13°F) and 40°C (104°F)	PAROIL Extra



Never mix synthetic with mineral oil.

When changing from mineral to synthetic oil (or the other way around), you will need to do an extra rinse.

After doing the complete change procedure to synthetic oil, run the unit for a few minutes to allow good and complete circulation of the synthetic oil. Then drain the synthetic oil again and fill again with new synthetic oil. To set correct oil levels, proceed as in normal instruction.

Specifications PAROIL

PAROIL from Atlas Copco is the ONLY oil tested and approved for use in all engines built into Atlas Copco compressors and generators.

Extensive laboratory and field endurance tests on Atlas Copco equipment have proven PAROIL to match all lubrication demands in varied conditions. It meets stringent quality control specifications to ensure your equipment will run smoothly and reliably.

The quality lubricant additives in PAROIL allow for extended oil change intervals without any loss in performance or longevity.

PAROIL provides wear protection under extreme conditions. Powerful oxidation resistance, high chemical stability and rust- inhibiting additives help reduce corrosion, even within engines left idle for extended periods.

PAROIL contains high quality anti-oxidants to control deposits, sludge and contaminants that tend to build up under very high temperatures.

PAROIL's detergent additives keep sludge forming particles in a fine suspension instead of allowing them to clog your filter and accumulate in the valve/rocker cover area.

PAROIL releases excess heat efficiently, whilst maintaining excellent bore-polish protection to limit oil consumption.

PAROIL has an excellent Total Base Number (TBN) retention and more alkalinity to control acid formation.

PAROIL prevents Soot build-up.

PAROIL is optimized for the latest low emission EURO -3 & -2, EPA TIER II & III engines running on low sulphur diesel for lower oil and fuel consumption.

PAROIL Extra and PAROIL E

Synthetic engine oil PAROIL Extra

PAROIL Extra is a Synthetic ultra high performance diesel engine oil with a high viscosity- index. Atlas Copco PAROIL Extra is designed to provide excellent lubrication from start-up in temperatures as low as -25°C.

	Liter	US gal	Imp gal	cu.ft	Order number
can	5	1.3	1.1	0.175	1630 0135 00
barrel	20	5.3	4.4	0.7	1630 0136 00

Mineral engine oil PAROIL E

PAROIL E is a mineral based high performance diesel engine oil with a high viscosity- index. Atlas Copco PAROIL E is designed to provide a high level of performance and protection in standard ambient conditions as from -15°C.

	Liter	US gal	Imp gal	cu.ft	Order number
can	5	1.3	1.1	0.175	1615 5953 00
can	20	5.3	4.4	0.7	1615 5954 00
barrel	209	55.2	46	7.32	1615 5955 00
barrel	1000	264	220	35	1630 0096 00

Adjustments & service procedures

Engine oil level check



Never mix oils of different brands or types. Use only non-toxic oils where there is a risk of inhaling delivered air.

Consult also the Engine Operation Manual for the oil specifications, viscosity recommendations and oil change intervals.

For intervals, see “Maintenance” on page 31.

Check engine oil level according to the instructions in the Engine Operation Manual and top up with oil if necessary.

Oil and oil filter change

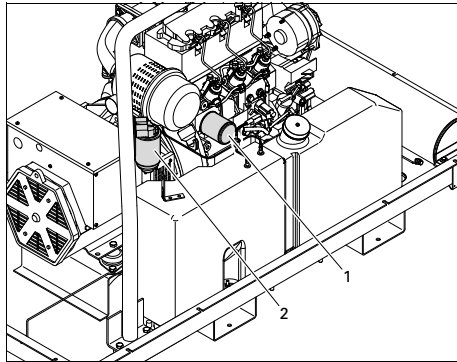

- 1 | Oil filter (engine)
- 2 | Fuel filter

For further details, see “Preventive maintenance schedule for the generator” on page 33.

Cleaning coolers

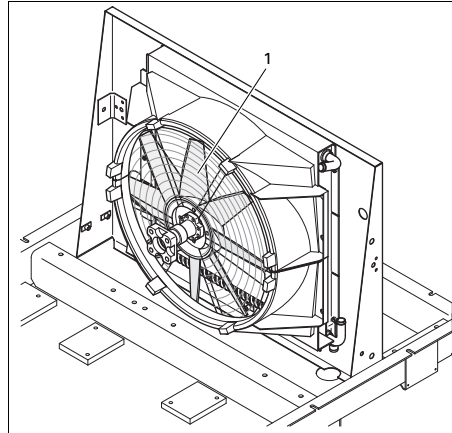

- Keep the oil-cooler (1) clean to maintain the cooling efficiency.
- The fan side surface of engine oil cooler is accessible by removing the fan cowl upper part.
- The opposite surface of engine oil cooler is accessible by removing the centre part of the front baffles.



Remove any dirt from the coolers with a fibre brush. Never use a wire brush or metal objects.

- Steam cleaning in combination with a cleansing agent may be applied.



To avoid damaging the coolers, angle between jet and coolers should be approx. 90°.

Protect the electrical and controlling equipment, air filters, etc. against penetration of moisture.

Make sure to not steam clean the alternator.

- Close the service door(s).



Never leave spilled liquids such as fuel, oil, water and cleansing agents in or around the generator.

Cleaning fuel tank



Observe all relevant environmental and safety precautions.

- Place an appropriate drain pan under the drainplug of the fuel tank.
- Remove the drain plug.
- Lift the towbar (see “Towing instructions” on page 49) and tilt the generator approx. 15° to remove all fuel, dirt and water.
- Clean the fuel tank and fix the drain plug handtight.



Never leave spilled liquids such as fuel, oil, water and cleansing agents in or around the generator.

- Refill the fuel tank with clean fuel.

Battery care



Before handling batteries, read the relevant safety precautions and act accordingly.

If the battery is still dry, it must be activated as described in section “Activating a dry-charged battery”.

The battery must be in operation within 2 months from being activated; if not, it needs to be recharged first.

Electrolyte



Read the safety instructions carefully.

Electrolyte in batteries is a sulphuric acid solution in distilled water.

The solution must be made up before being introduced into the battery.

Activating a dry-charged battery

- Take out the battery.
- Battery and electrolyte must be at equal temperature above 10°C.
- Remove cover and/or plug from each cell.
- Fill each cell with electrolyte until the level reaches 10 to 15 mm above the plates, or to the level marked on the battery.
- Rock the battery a few times so that possible air bubbles can escape; wait 10 minutes and check the level in each cell once more; if required, add electrolyte.
- Refit plugs and/or cover.
- Place the battery in the generator.

Recharging a battery

Before and after charging a battery, always check the electrolyte level in each cell; if required, top up with distilled water only. When charging batteries, each cell must be open, i.e. plugs and/or cover removed.



Use a commercial automatic battery charger according to its manufacturer’s instructions.

Apply with preference the slow charging method and adjust the charge current according to the following rule of thumb: battery capacity in Ah divided by 20 gives safe charging current in Amp.

Battery maintenance

- Keep the battery clean and dry.
- Keep the electrolyte level at 10 to 15 mm above the plates or at the indicated level; top up with distilled water only.
- Keep the terminals and clamps tight, clean, and lightly covered with petroleum jelly.

Air filter engine

Main parts

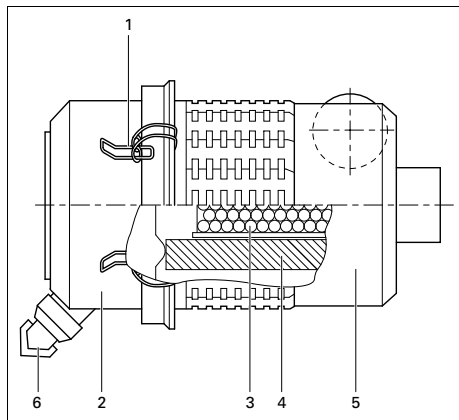

- 1 | Snap clips
- 2 | Dust trap
- 3 | Safety cartridge
- 4 | Filter element
- 5 | Filter housing
- 6 | Vacuator valve

Recommendation



The Atlas Copco air filters are specially designed for the application. The use of non-genuine air filters may lead to severe damage of engine and/or alternator. **Never run the generator without air filter element.**

- New elements must also be inspected for tears or punctures before installation.
- Discard the filter element (4) when damaged.
- In heavy duty applications it is recommended to install a safety cartridge which can be ordered with part no.: 2914 9307 00.
- A dirty safety cartridge (3) is an indication of a malfunctioning air filter element (4). Replace the element and the safety cartridge in this case.
- The safety cartridge (3) cannot be cleaned.

Cleaning the dust trap

To remove dust from the dust trap (2) pinch the vacuator valve (6) several times.

Replacing the air filter element

- Release the snap clips (1) and remove the dust trap (2). Clean the trap.
- Remove the element (4) from the housing (5).
- Reassemble in reverse order of dismantling.
- Inspect and tighten all air intake connections.
- Reset the vacuum indicator.

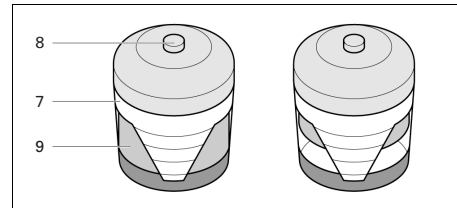

- 7 | Air filter contamination indicator
- 8 | Reset button
- 9 | Yellow indicator

Fuel system

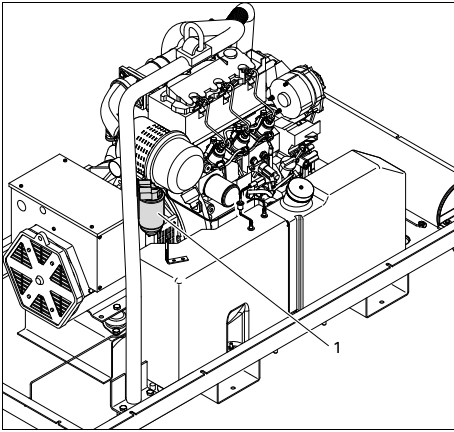

Replacing the filter element:

- Unscrew the filter element (1) from the adapter head.
- Clean the adapter head sealing surface. Lightly oil the gasket of the new element and screw the latter onto the header until the gasket is properly seated, then tighten with both hands.
- Check for fuel leaks once the engine has been restarted.

Liability

The manufacturer does not accept any liability for any damage arising from the use of non-original parts and for modifications, additions or conversions made without the manufacturer's approval in writing.

Storage of the generator

Storage

- Store the generator in a dry, frost-free room which is well ventilated.
- Run the engine regularly, e.g. once a week, until it is warmed up. If this is impossible, extra precautions must be taken:
 - Consult the engine's operator manual.
 - Remove the battery. Store it in a dry, frost-free room. Keep the battery clean and its terminals lightly covered with petroleum jelly. Recharge the battery regularly.
 - Clean the generator and protect all electrical components against moisture.
 - Place silica gel bags, VCI paper (Volatile Corrosion Inhibitor) or another drying agent inside the generator and close the doors.
 - Stick sheets of VCI paper with adhesive tape on the bodywork to close off all openings.
 - Wrap the generator, except the bottom, with a plastic bag.

Preparing for operation after storage

Before operating the generator again, remove the wrapping, VCI paper and silica gel bags and check the generator thoroughly (go through the checklist "Before starting" on page 29).

- Consult the engine's operator manual.
- Check that the insulation resistance of the generator exceeds 1 MΩ.
- Replace the fuel filter and fill the fuel tank. Vent the fuel system.
- Reinstall and connect the battery, if necessary after being recharged.
- Submit the generator to a test run.

Checks and trouble shooting



Never perform a test run with connected power cables. Never touch an electrical connector without a voltage check.

When a failure occurs, always report what you experienced before, during and after the failure. Information with regard to the load (type, size, power factor, etc.), vibrations, exhaust gas colour, insulation check, odours, output voltage, leaks and damaged parts, ambient temperature, daily and normal maintenance and altitude might be helpful to quickly locate the problem. Also report any information regarding the humidity and location of the generator (e.g. close to sea).

Checking voltmeter P4

- Put a voltmeter in parallel with voltmeter P4 on the control panel.
- Check that the read-out of both voltmeters is the same.
- Stop the generator and disconnect one terminal.
- Check that the internal resistance of the voltmeter is high.

Checking ammeter P1

- Measure during the load, by means of a clamp-on probe, the outgoing current in the first phase (L1).
- Compare the measured current with the current indicated on ammeter P1. Both readings should be the same.

Alternator troubleshooting

<i>Symptom</i>	<i>Possible cause</i>	<i>Corrective action</i>
<i>Alternator gives 0 Volt</i>	Blown fuse. No residual voltage.	Replace fuse. Excite the alternator by applying a 12V battery voltage with a 30 Ω resistor in series on the + and - terminals of the electronic regulator, respecting the polarities.
<i>After being excited the alternator still gives 0 Volt.</i>	Connections are interrupted.	Check connection cables, measure winding resistances and compare with values mentioned in the alternator manual.
<i>Low voltage at no load</i>	Voltage potentiometer out of setting. Intervention of protection. Winding failure.	Reset voltage. Check frequency/voltage regulator. Check windings.
<i>High voltage at no load</i>	Voltage potentiometer out of setting. Failed regulator.	Reset voltage. Substitute regulator.
<i>Lower than rated voltage at load</i>	Voltage potentiometer out of setting. Intervention by protection. Failed regulator. Rotating bridge failure.	Reset voltage potentiometer. Current too high, power factor lower than 0.8; speed lower than 10% of rated speed. Substitute regulator. Check diodes, disconnect cables.
<i>Higher than rated voltage at load</i>	Voltage potentiometer out of setting. Failed regulator.	Reset voltage potentiometer. Substitute regulator.
<i>Unstable voltage</i>	Speed variation in engine. Regulator out of setting.	Check regularity of rotation. Regulate stability of regulator by acting on STABILITY potentiometer.

Engine trouble shooting

The table below gives an overview of the possible engine problems and their possible causes.

The starter motor turns the engine too slowly

- Battery capacity too low.
- Bad electrical connection.
- Fault in starter motor.
- Wrong grade of lubricating oil.

The engine does not start or is difficult to start

- Starter motor turns engine too slowly.
- Fuel tank empty.
- Fault in fuel control solenoid.
- Restriction in a fuel pipe.
- Fault in fuel lift pump.
- Dirty fuel filter element.
- Air in fuel system.
- Fault in atomisers.
- Cold start system used incorrectly.
- Fault in cold start system.
- Restriction in fuel tank vent.
- Wrong type or grade of fuel used.
- Restriction in exhaust pipe.

Not enough power

- Restriction in a fuel pipe.
- Fault in fuel lift pump.
- Dirty fuel filter element.
- Restriction in air filter/cleaner or induction system.
- Air in fuel system.
- Fault in atomisers or atomisers of an incorrect type.
- Restriction in fuel tank vent.
- Wrong type or grade of fuel used.
- Restricted movement of engine speed control.
- Restriction in exhaust pipe.
- Engine temperature is too high.
- Engine temperature is too low.

Misfire

- Restriction in a fuel pipe.
- Fault in fuel lift pump.
- Dirty fuel filter element.
- Air in fuel system.
- Fault in atomisers or atomisers of an incorrect type.
- Fault in cold start system.
- Engine temperature is too high.
- Incorrect valve tip clearances.

The pressure of the lubricating oil is too low

- Wrong grade of lubricating oil.
- Not enough lubricating oil in sump.
- Defective gauge.
- Dirty lubricating oil filter element.

High fuel consumption

- Restriction in air filter/cleaner or induction system.
- Fault in atomisers or atomisers of an incorrect type.
- Fault in cold start system.
- Wrong type or grade of fuel used.
- Restricted movement of engine speed control.
- Restriction in exhaust pipe.
- Engine temperature is too low.
- Incorrect valve tip clearances.

Black exhaust smoke

- Restriction in air filter/cleaner or induction system.
- Fault in atomisers or atomisers of an incorrect type.
- Fault in cold start system.
- Wrong type or grade of fuel used.
- Restriction in exhaust pipe.

- Engine temperature is too low.
- Incorrect valve tip clearances.
- Engine overload.

Blue or white exhaust smoke

- Wrong grade of lubricating oil.
- Fault in cold start system.
- Engine temperature is too low.

The engine knocks

- Fault in fuel lift pump.
- Fault in atomisers or atomisers of an incorrect type.
- Fault in cold start system.
- Wrong type or grade of fuel used.
- Engine temperature is too high.
- Incorrect valve tip clearances.

The engine runs erratically

- Fault in fuel control.
- Restriction in a fuel pipe.
- Fault in fuel lift pump.
- Dirty fuel filter element.
- Restriction in air filter/cleaner or induction system.
- Air in fuel system.
- Fault in atomisers or atomisers of an incorrect type.
- Fault in cold start system.

- Restriction in fuel tank vent.
- Restricted movement of engine speed control.
- Engine temperature is too high.
- Incorrect valve tip clearances.

Vibration

- Fault in atomisers or atomisers of an incorrect type.
- Restricted movement of engine speed control.
- Engine temperature is too high.
- Fan damaged.
- Fault in engine mounting or flywheel housing.

The pressure of the lubricating oil is too high

- Wrong grade of lubricating oil.
- Defective gauge.

The engine temperature is too high

- Restriction in air filter/cleaner or induction system.
- Fault in atomisers or atomisers of an incorrect type.
- Fault in cold start system.
- Restriction in exhaust pipe.
- Fan damaged.
- Too much lubricating oil in sump.
- Restriction in air or coolant passages of radiator.

Crankcase pressure

- Restriction in breather pipe.
- Vacuum pipe leaks or fault in exhauster.

Bad compression

- Restriction in air filter/cleaner or induction system.
- Incorrect valve tip clearances.

The engine starts and stops

- Dirty fuel filter element.
- Restriction in air filter/cleaner or induction system.
- Air in fuel system.

The engine shuts down after approx. 15 sec.

- Bad connection towards oil pressure switch/coolant temperature switch.

Options available for QAX 12-20-24-30-35 Dd units

Circuit diagrams

The engine control circuit diagrams and the power circuit diagrams for the standard QAX units, for the units with options and for the units with combined options are:

Power circuit

Unit	Circuit
QAX 12 Dd - 1-phase	9822 0997 36
QAX 12-20-30 Dd - 3-phase	9822 0997 35
QAX 24-35 Dd - 3-phase	9822 0997 32

Engine control circuit

Unit	Circuit
QAX 12-20-24-30-35 Dd - Qc1002™	9822 0997 83

Overview of the electrical options

The following electrical options are available:

- Earth leakage relay
- IT-relay (only for the QAX 12-20-30 Dd)
- Single phase socket (only for the QAX 12 Dd)
- 16 A or 32 A middle socket (only for the QAX 30 Dd)
- COSMOS™ retrofit kit
- Integrated spark arrestor

Description of the electrical options

Earth leakage relay

The Earth relay option provides a detector that will trip the main circuit breaker Q1 when an earth fault current is detected.

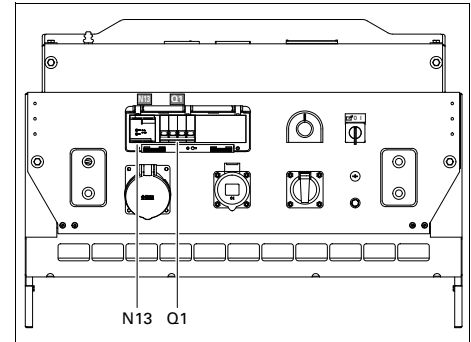

N13Earth leak detector

Detects and indicates an earth fault current and activates the main circuit breaker Q1. The detection level can be set at 30 mA fixed with instantaneous trip but can also be adjusted between 0.1 A and 1 A with time delayed (0 - 0.5 sec) trip. N13 has to be reset manually after eliminating the problem (reset button marked R).

Q1Main circuit breaker

IT-relay (only for the QAX 12-20-30 Dd)

The generator is wired for an IT network i.e. no supply lines of the power supply are directly earthed. A failure in insulation resulting in a too low insulation resistance, is detected by the insulation monitoring relay.

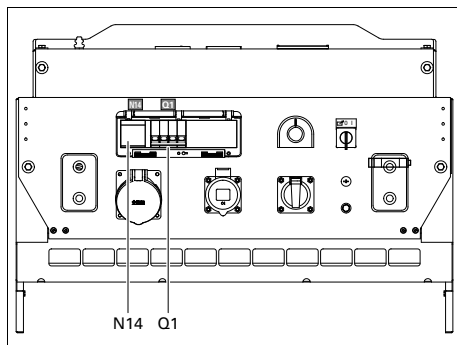

N14.....Insulation monitoring relay

Checks the insulation resistance and activates Q1 when the insulation resistance is too low. It can be reset by pushing the reset button.

Q1.....Main circuit breaker



The generator shall not be operated with other networks (such as TT or TN). Doing so will cause tripping of the insulation monitoring relay.

At each start-up and any time a new load is connected, the insulation resistance must be verified. Check for the correct setting of the insulation monitoring relay (factory set at 13 k Ω).

COSMOS™ retrofit kit

COSMOS™ is a web-based global remote monitoring system that electronically tracks every aspect of equipment from its location to its operating parameters. The Cosmos system can send e-mails or SMS messages to the contractor or owner in real time, with all critical and non-critical events and data involving your compressors and generators. It allows optimal servicing.

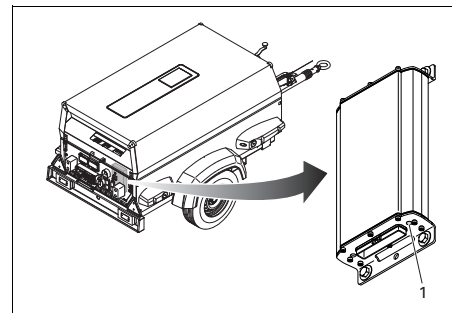

When starting up the generator, the green Power Led (1) of the Cosmos module will light up when the installation has been carried out correctly.

For information about COSMOS™, consult your local Atlas Copco dealer.

Overview of the mechanical options

The following mechanical options are available:

- Forklift slots
- Undercarriage (axle, towbar, towing eyes)
- Road signalisation
- Lighting tower (only for Metal Canopy 50 Hz units)

Description of the mechanical options

The QAX 12-20-24-30-35 Dd can be optionally equipped with forklift slots or an undercarriage.

Forklift slots

To be able to lift the QAX 12-20-24-30-35 Dd by means of a forklift, rectangular holes are provided in the frame.

Undercarriage (axle, towbar, towing eyes)

The undercarriage is equipped with an adjustable or fixed towbar with DIN-eye, AC-eye, IT-eye, GB-eye, NATO-eye or ball coupling.

When using this option

- Make sure that the towing equipment of the vehicle matches the towing eye before towing the generator.
- Never move the generator while electrical cables are connected to the unit.
- Always apply the hand brake when parking the generator.
- Leave enough space for operation, inspection and maintenance (at least 1 meter at each side).

To maintain the undercarriage

- Check the tightness of the towbar bolts, the axle bolts and the wheel nuts at least twice a year and after the initial 50 hours of operation.
- Grease the wheel axle suspension bearings and the spindle of the brake handle at least twice a year. Use ball bearing grease for the wheel bearings and graphite grease for the drawbar and spindle.
- Check the brake system twice a year.
- Check the condition of the vibration dampers twice a year.
- Repack the wheel hub bearings once a year using grease.

Parking, towing and lifting instructions



The operator is expected to apply all relevant safety precautions, including those mentioned on page 6 to page 12 of this book.

- Before putting the generator in to use, check the brake system as described in the section “Brake adjustment” on page 47.
- After the first 100 km travel:
 - Check and retighten the wheel nuts and towbar bolts to the specified torque. See section “Height adjustment (with adjustable towbar)” on page 49 and “Torque values” on page 80.
 - Check “Brake adjustment” on page 47.

Parking instructions

Non-adjustable towbar with standard support leg without brakes:

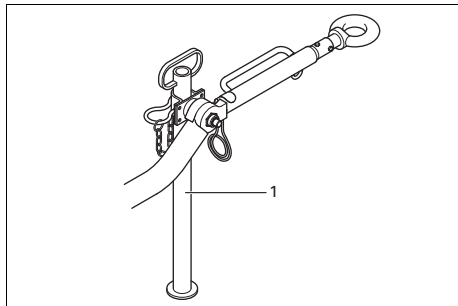

Adjustable towbar with jockey wheel and brakes:

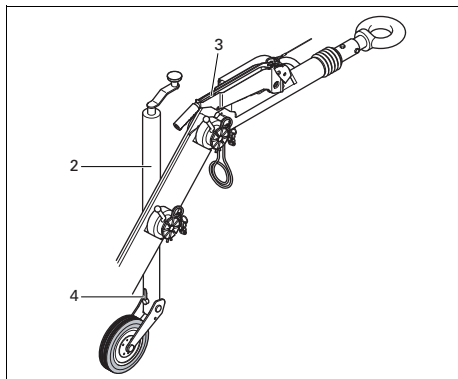

- 1 | Support leg
- 2 | Jockey wheel
- 3 | Parking brake handle
- 4 | Blocking pin

When parking a generator, secure support leg (1) or jockey wheel (2) to support the generator in a level position. Be sure that the jockey wheel (2) is blocked by the blocking pin (4).

Apply parking brake by pulling parking brake handle (3) upwards. Place the generator as level as possible; however, it can be operated temporarily in an out-of-level position not exceeding 15°. If the generator is parked on sloping ground, immobilize the generator by placing wheel chocks (available as option) in front of or behind the wheels. Locate the rear-end of the generator upwind, (see figure below), away from contaminated wind-streams and walls. Avoid recirculation of exhaust air from the engine. This causes overheating and engine power decrease.

Parking position of jockey wheel

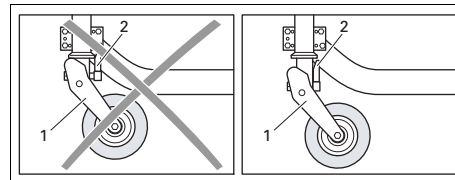

- 1 | Jockey wheel
- 2 | Blocking pin

Rear-end of generator upwind

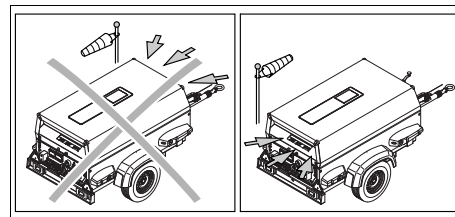

Brake adjustment



Before jacking up the generator, connect it to a towing vehicle or attach a weight of minimum 50 kg to the towbar.

Brake shoe adjustment

Check the thickness of the brake lining. Remove both black plastic plugs (5), one on each wheel. When the brake lining has been worn to a thickness of 1 mm or less, the brake shoes have to be replaced. After inspection and/or replacement re-insert both plugs.

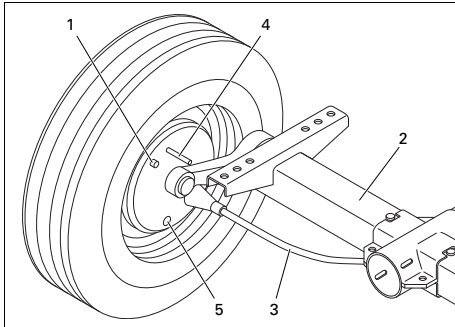

- | | |
|---|----------------|
| 1 | Adjusting bolt |
| 2 | Axle |
| 3 | Braking cable |
| 4 | Pin 4 mm |
| 5 | Plastic plug |

- Brake shoe adjustment re-establishes the brake lining-to-drum clearance and compensates for lining wear.
- Lift and support the generator. Make sure that all brakes are off (overrunbrake and hand brake lever). The brake cables must be free from tension. Lock the swivel cams of the wheel brake from the outside by means of a pin 4 mm (4) through the hole as shown in the figure above.
- Turn the adjusting bolt (1) clockwise with a wrench till the wheel locks up. Center the brake shoes by actuating the parking brake several times.
- Turn the adjusting bolt anti-clockwise until the wheel is running free in direction of travel (approx. 1 full turn of the adjusting bolt).
- Check the position of the equalizer (see “Brake cable adjustment” on page 48) with the parking brake actuated.
- Perpendicular position of equalizer = identical clearance of wheel brakes.
- Re-adjust the brake shoes, if necessary.
- To test, slightly apply the parking brake and check identical brake torque on left and right side.
- Remove locking pin (4). Remove clearance from brake cables (3).
- Check all lock nuts (see “Brake cable adjustment” on page 48).

Test procedure of brake cable adjustment

- Check if the towing eye rod of the overrun brake mechanism is in the outmost position.
- Check if the adjustable towbar (= option) is in the actual towing position.
- Apply the hand brake lever.
- Push the generator a few centimeters backwards so that the brake lever is automatically pulled further up.
- Check the position of the arrow marking 1 at the catch lock in combination with the arrow marking 2 at the toothed sector, according to the figure.

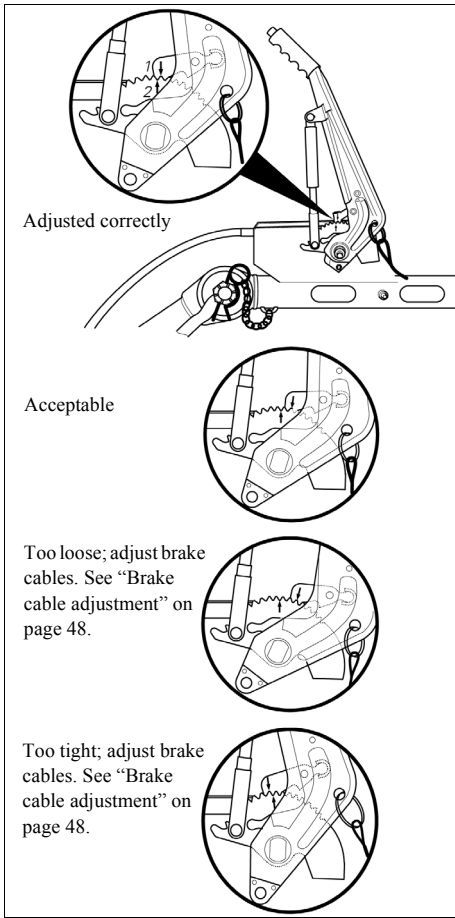

Brake cable adjustment

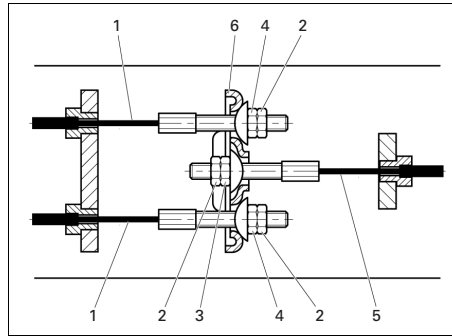

- 1 Brake cable
- 2 Lock nut
- 3 Adjusting nut
- 4 Brake cable nut
- 5 Main brake cable
- 6 Equalizer

- With the towing eye pulled out in the outmost position and the hand brake lever in the downward position (see figure below), loosen the lock nuts (2). Turn adjusting nuts (3) and brake cable nuts (4) clockwise until there is no slack in the brake mechanism. The equalizer must remain perpendicular to main brake cable (5).

- Apply the hand brake lever several times and repeat the adjustment. Tighten the nuts with their lock nuts (2). Remove the jack and the blocks.
- Road test the generator and brake several times. Check brake shoe and brake cable adjustment and if necessary adjust.

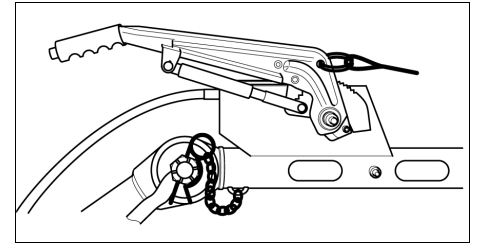

Towing instructions



Before towing the generator, ensure that the towing equipment of the vehicle matches the towing eye or ball connector, and ensure that the hood is closed and locked properly.

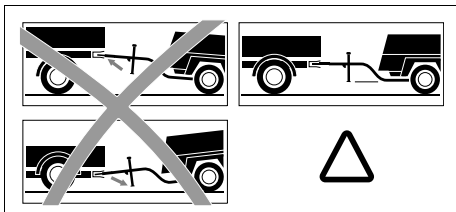

For both non-adjustable - and adjustable towbar, the towbar should be as level as possible and the generator and towing eye end in a level position.

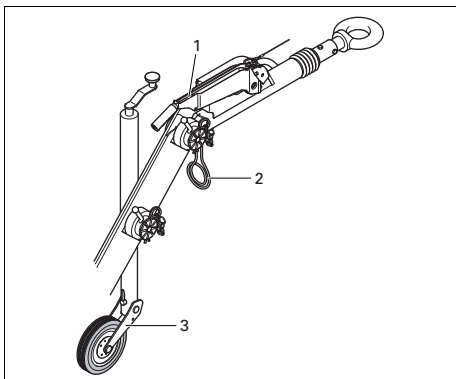

- 1 | Hand brake lever
- 2 | Breakaway cable
- 3 | Jockey wheel

Push the hand brake lever (1) completely downwards and connect breakaway cable (2) to the vehicle. Secure jockey wheel (3) or support leg in the highest possible position. The jockey wheel is prevented from turning (see “Parking instructions” on page 46).

Towing position of jockey wheel

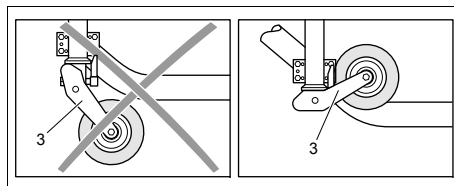

Height adjustment (with adjustable towbar)



Before towing the generator, make sure that the joints of the towbar are secured with maximum strength without damaging the towbar. Be sure that there is no clearance between the teeth of the joints.

For specific instruction see below !

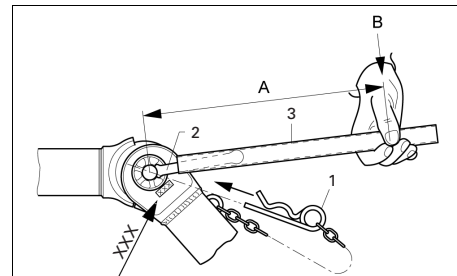

X X X	MA [Nm]	A [mm]	B [N]
ZV 2000	250-300	600	420-500
ZV 2500	350-400	600	580-660

- 1 | Spring pin
- 2 | Locking nut
- 3 | Extension tube

- Remove spring pin (1).
- Release locking nut (2) with support tools (extension tube 3).
- Adjust required height of the drawbar.
- Tighten locking nut (2) by hand first.
- Secondly tighten locking nut (2) with a tightening torque corresponding to table (see table above).
With an extension tube (3) (A corresponding to table) and handforce (B corresponding to table) easy tightening is possible.
- Fix locking nut (2) with spring pin (1).



Height adjustment should be undertaken on levelled ground and in coupled condition.

When readjusting, make sure that the front point of the towbar is horizontal to the coupling point.

Before starting a trip, make sure that the adjustment shaft is secure, so that the stability and safety is guaranteed while driving. If necessary tighten the locking nut (2) (corresponding to table).

Road signalisation

This option equips the undercarriage with road signalisation, approved by EC legislation.

Lighting tower (only for Metal Canopy 50 Hz units)

General description

The lighting tower option provides an undercarriage (frame, axle and towbar) and 6 halogen projectors of 1500 W each. There are two versions of undercarriages available: on-road (with road signalisation) and off-road (without road signalisation). The lighting tower is very useful for construction sites where no electricity nor lighting is available.

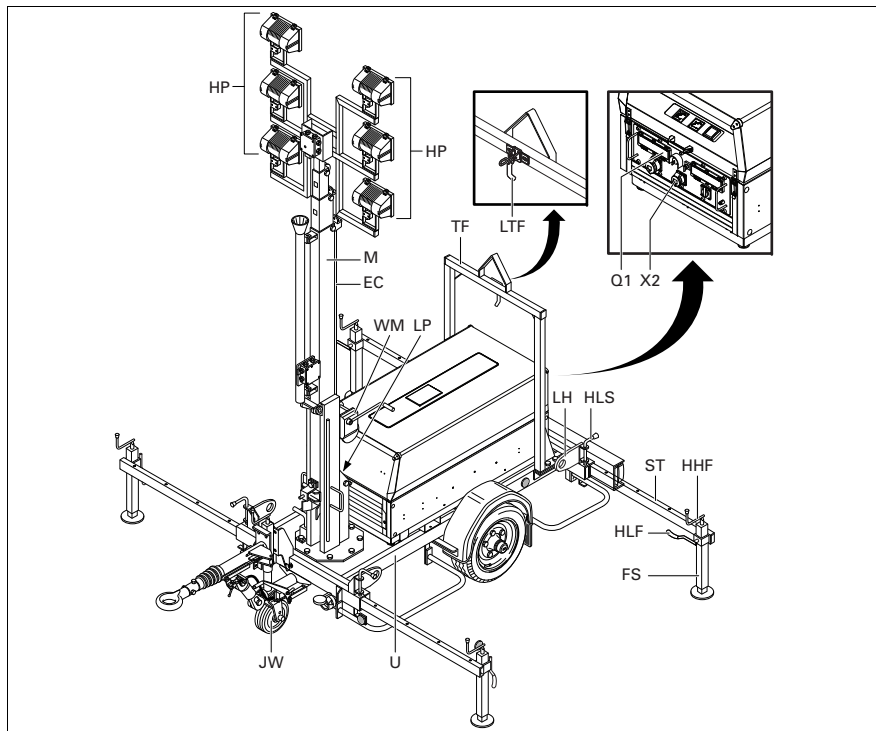

EC	Elevation cable
FS	Foot
HHF	Handle to adjust the height of the foot
HLF	Handle to lock/unlock the foot
HLS	Handle to lock/unlock the stabilizer
HP	Halogen projectors
JW	Jockey wheel
LH	Lifting hook
LP	Locking pin
LTF	Lever transport frame
M	Mast
PSC	Power supply cable
Q1	Main circuit breaker
ST	Stabilizer
TF	Transport frame
U	Undercarriage (on-road)
WM	Winding mechanism
X2	Outlet socket

Operating procedure

General guidelines

1. Check the terrain where the lighting tower has to be erected:
 - Maximum allowable slope of the terrain: the generator can be operated temporarily in an out-of-level position not exceeding 15°.
 - Absence of obstacles that could interfere with the erection of the lighting tower: (e.g. high voltage lines, constructions, ...)
2. The lighting tower should never be left unattended. When finishing activities on a site, the lighting tower should be lowered to its resting position.



When the genset is mounted on a lighting tower it is NOT permitted to use the lifting eye for lifting of the assembly. Instead use the 4 lifting hooks (LH) situated at the corners of the lighting tower undercarriage (U). Ignoring these instructions may lead to damage and personal injury !

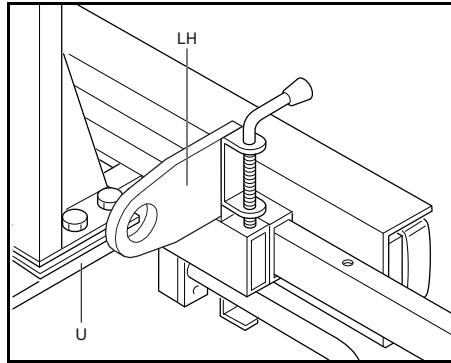

3. Before moving the unit, ALWAYS lower the mast (M) and secure it on the transport frame (TF).
4. Never move the generator while power supply cables are connected to the unit.



When the lighting tower is mounted on an off-road undercarriage, never exceed the maximum speed limit of 30 km/h!

Erection of the lighting tower

1. Positioning of the generator mounted on the lighting tower.
 - Locate the rear-end of the generator upwind, (see figure below), away from contaminated wind-streams and walls. Avoid recirculation of exhaust air from the engine. This causes overheating and engine power decrease.

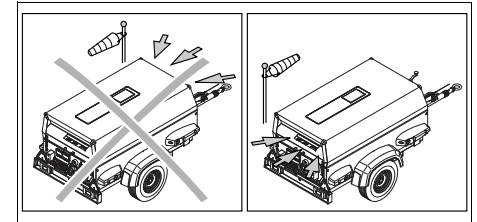

- Immobilize the generator by applying the handbrake or support leg or using wheel chocks in front of or behind the wheels.
- Position the generator mounted on the lighting tower as level as possible by using the vertical adjustment of the jockey wheel (or support leg).

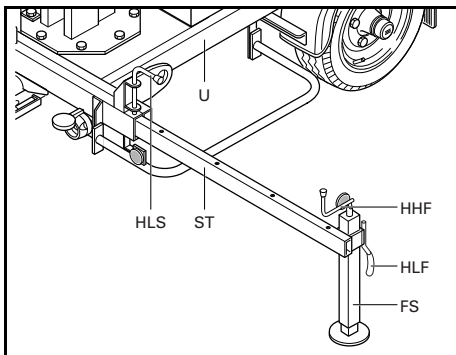

2. Extend the four stabilizers (ST) at the corners as far as possible and lock them with the appropriate levers (HLS). All stabilizers should be extended to the same length.

Unlock the feet of the stabilizers (FS) by using the handle aside of the stabilizer (HLF) and bring them down as far as possible. Ensure that the feet are locked in one of the foreseen holes.

Wind down the foot (FS) using the handle on top of the stabilizer (HHF), until the foot touches the ground and clamps the stabilizer (ST) firmly to the undercarriage (U).



If the underground is too loose, it is recommended to place a flat support (wooden block, ...) under the stabilizer.

3. Erect the mast of the lighting tower:

- Loosen the elevation cable (EC) by turning the lever of the winding mechanism (WM) clockwise. This makes it more easy to unlock the mast.
- Unlock the mast by raising the lever (LTF) situated at the back of the transport frame (TF).

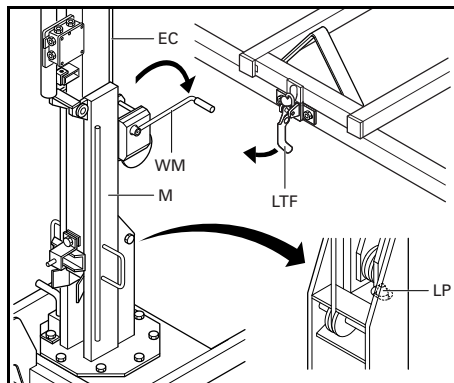

- Raise the mast (M) from the horizontal resting position to the vertical position by turning the lever of the winding mechanism (WM) counterclockwise. When the mast is in vertical position, check whether the locking pin (LP) secures the vertical position of the mast.
- Raise the mast (M) to the desired height by turning further the lever of the winding mechanism (WM).

4. Turning the mast of the lighting tower.

The mast of the lighting tower can be turned to the left and to the right to locked positions on 45°, 90°, 135° and 180°. First unlock the mast by pulling on the lever (LM), then turn the mast to the desired position and lock the mast again with the lever.

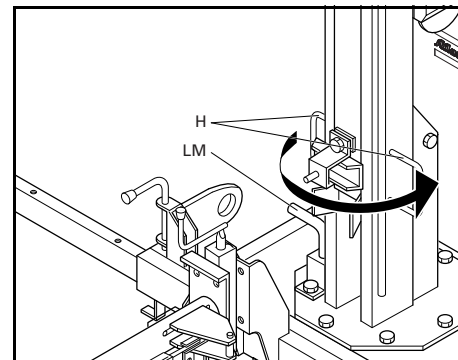

Starting the generator and switching the lights on and off



Only start the generator and switch on the lights when the lighting tower is erected to the desired position.

1. To switch the lamps (HP) on, plug the connector of the power supply cable towards the lamps (PSC) in outlet socket X2 of the generator.
2. Check that the main circuit breaker Q1 is switched off.
3. Start up the generator (see “Operating Qc1002™”).
4. To switch on the lights, switch on the main circuit breaker Q1. To switch off the lights, switch off the main circuit breaker Q1.



When pushing on the emergency stop the main circuit breaker Q1 is automatically switched off.

Taking down the lighting tower



Do not take down the lighting tower with lights switched on and generator running.

1. Check that the mast (M) is turned to the original position (with the lights directed to the back of the lighting tower) and locked.
2. To take down the lighting tower follow the procedure of the erection of the lighting tower in reversed order.

Additional checks:

- After locking the mast in its horizontal position, tighten the elevation cable (EC) by turning on the lever of the winding mechanism (WM).
- Make sure ALWAYS to retract the stabilizers (ST).
- After retracting, check that the stabilizers (ST) are locked with the appropriate handles (HLS). Check that the foots of the stabilizers (FS) are tightened firmly (using the handles HHF and HLF).

Lighting tower maintenance

- Refer to the maintenance instructions mentioned in the chapter dealing with the “Undercarriage” option.
- Check the condition of the tower, the tightness of its bolts and the fixation of the elevation cable (EC) at least twice a year.



Do not use the handles on the lighting tower for towing or lifting the generator.

Technical specifications

Technical specifications for QAX 12 Dd

Readings on gauges

<i>Gauge</i>	<i>Reading</i>	<i>Unit</i>
Ammeter L1 (P1)	Below max. rating	A
Voltmeter (P4)	Below max. rating	V

Settings of switches

<i>Switch</i>	<i>Function</i>	<i>Activates at</i>
Engine oil pressure	Shut down	0.5 bar
Engine coolant temperature	Shut down	105°C

Specifications of the engine/alternator/unit

		<i>400 V - 3-phase</i>	<i>230 V - 1-phase</i>
<i>Reference conditions 2) 3)</i>	Rated frequency	50 Hz	50 Hz
	Rated speed	1500 rpm	1500 rpm
	Generator service duty	PRP	PRP
	Absolute air inlet pressure	100 kPa	100 kPa
	Relative air humidity	30%	30%
	Air inlet temperature	25°C	25°C
<i>Limitations 1)</i>	Maximum ambient temperature	50°C	50°C
	Altitude capability	4000 m	4000 m
	Maximum relative air humidity	< 100%	< 100%
	Minimum starting temperature	-10°C	-10°C
	Minimum starting temperature aided	NA	NA
<i>Performance data 1) 2) 4)</i>	Rated active power (PRP) 3-phase	10 kW	-
	Rated active power (PRP) 1-phase	-	10.9 kW
	Rated power factor (lagging) 3-phase	0.8	

Rated power factor (lagging) 1-phase	-	1.0
Rated apparent power (PRP) 3-phase	12.5 kVA	-
Rated apparent power (PRP) 1-phase	-	10.9 kVA
Rated voltage 3-phase, line to line	400 V	-
Rated voltage 1-phase, line to line	-	230 V
Rated current 3-phase	18 A	-
Rated current 1-phase	-	47.6 A
Performance class (acc.ISO 8528-5:1993)	G2	G2
Single step load acceptance (0-PRP)	10.0 kW	10.9 kW
	100%	100%
Frequency droop	< 5%	< 5%
Fuel consumption at no load (0%)	0.76 kg/h	0.76 kg/h
Fuel consumption at 50% load	1.54 kg/h	1.54 kg/h
Fuel consumption at 75% load	2.11 kg/h	2.11 kg/h
Fuel consumption at full load (100%)	2.63 kg/h	2.63 kg/h
Specific fuel consumption	0.285 kg/kWh	0.295 kg/kWh
Fuel autonomy at full load	12.6 h	11.5 h
Max. oil consumption at full load	0.0089 l/h	0.0097 l/h
Maximum sound power level (LWA) measured according to 2000/14/EC OND		
with metal canopy	91 dB(A)	91 dB(A)
with PE canopy (optional)	89 dB(A)	89 dB(A)
Capacity of fuel tank	40 l	40 l
Single step load capability (0-PRP)	10.0 kW	10.9 kW
	100%	100%
Mode of operation	PRP	PRP
Site	land use	land use
Operation	single	single
Start-up and control mode	manual/automatic (remote)	manual/automatic (remote)
Start-up time	unspecified	unspecified
Mobility/Config. acc. to ISO 8528-1:1993 (optional)	transportable/D mobile/E	transportable/D mobile/E
Mounting	fully resilient	fully resilient

Application data

<i>Alternator</i>	Climatic exposure	open air	open air
	Status of neutral (ELR-config)	earthed	NA
	Status of neutral (IT-config)	insulated	NA
	Standard	IEC34-1	IEC34-1
	Make	ISO 8528-5	ISO 8528-5
	Model	Leroy Somer	Leroy Somer
	Rated output, class H temp. rise	LSA 40VS2	LSA 40M5
	Degree of protection	12.5 kVA	20 kVA
	Insulation stator class	IP 23	IP 23
	Insulation rotor class	H	H
	Number of wires	H	H
<i>Engine</i>	Standard	12	12
	Type DEUTZ	ISO 3046	ISO 3046
	Rated net output	ISO 8528-2	ISO 8528-2
	Coolant	F2M 2011 F	F2M 2011 F
	Combustion system	12 kW	12 kW
	Aspiration	oil	oil
	Number of cylinders	direct injection	direct injection
	Swept volume	natural	natural
	Speed governing	2 - in line	2 - in line
	Capacity of oil sump	1.55 l	1.55 l
	Capacity of cooling system	mechanical	mechanical
	Electrical system	6 l	6 l
	Emission compliance	8 l	8 l
		12 Vdc	12 Vdc
		NA	NA
<i>Power circuit</i>	Circuit-breaker, 3-phase		
	Number of poles	4	2
	Thermal release I _t (thermal release is higher at 25°C)	20 A	50 A
	Magnetic release I _m	3..5xI _n	3..5xI _n

Unit

Fault current protection		
Residual current release IDn (ELR-config)	0.3 A	0.3 A
Insulation resistance (IT-config)	10-100 kOhm	10-100 kOhm
Outlet sockets		
	Domestic (1x)	Domestic (1x)
	2P + E	2P + E
	16 A 230 V	16 A 230 V
	CEE form (1x)	CEE form (1x)
	3P + N + E	3P + N + E
	16 A 400 V	32 A 230 V
	CEE form (1x)	CEE form (1x)
	3P + N + E	3P + N + E
	32 A 400 V	63 A 230 V
Dimensions with undercarriage (adj. with breaks) (LxWxH)	3562 x 1410 x 1258 mm	3562 x 1410 x 1258 mm
Dimensions with undercarriage (fixed with breaks) (LxWxH)	3160 x 1410 x 1258 mm	3160 x 1410 x 1258 mm
Dimensions without undercarriage (LxWxH)	2016 x 1040 x 1019 mm	2016 x 1040 x 1019 mm
Weight net mass - Box	672 kg	691 kg
Weight wet mass - Box	706 kg	725 kg
Weight net mass - Undercarriage AB	814 kg	833 kg
Weight wet mass - Undercarriage AB	848 kg	867 kg
Weight net mass - Undercarriage FB	799 kg	718 kg
Weight wet mass - Undercarriage FB	833 kg	852 kg

Notes

- 1) See derating diagram or consult the factory for other conditions.
- 2) At reference conditions unless otherwise stated.
- 3) Rating definition (ISO 8528-1):
 LTP: Limited Time Power is the maximum electrical power which a generating set is capable of delivering (at variable load), in the event of a utility power failure (for up to 500 hours per year of which a maximum of 300 hours is continuous running). No overload is permitted on these ratings. The alternator is peak continuous rated (as defined in ISO 8528-3) at 25°C.
 PRP: Prime Power is the maximum power available during a variable power sequence, which may be run for an unlimited number of hours per year, between stated maintenance intervals and under the stated ambient conditions. A 5% overload is permitted for 1 hour in 12 hours. The permissible average power output during a 24h period shall not exceed the stated load factor of 80%.
- 4) Specific mass fuel used: 0.86 kg/l.

Derating factor %

Height (m)	Temperature (°C)										
	0	5	10	15	20	25	30	35	40	45	50
0	100	100	100	100	100	100	97	95	92	89	86
500	100	100	98	97	95	94	91	89	86	83	81
1000	95	93	92	90	89	88	85	83	80	78	75
1500	88	87	85	84	83	81	79	77	75	72	70
2000	81	80	79	78	76	75	73	71	69	67	65
2500	74	73	72	71	70	69	67	65	63	61	59
3000	68	67	66	65	64	63	61	59	57	56	54
3500	61	60	59	58	57	56	55	53	52	50	49
4000	54	53	53	52	51	50	49	47	46	45	43

Technical specifications for QAX 20 Dd

Readings on gauges

<i>Gauge</i>	<i>Reading</i>	<i>Unit</i>
Ammeter L3 (P1)	Below max. rating	A
Voltmeter (P4)	Below max. rating	V

Settings of switches

<i>Switch</i>	<i>Function</i>	<i>Activates at</i>
Engine oil pressure	Shut down	0.5 bar
Engine coolant temperature	Shut down	105°C

Specifications of the engine/alternator/unit

		<i>400 V - 3-phase</i>
<i>Reference conditions 3)</i>	Rated frequency	50 Hz
	Rated speed	1500 rpm
	Generator service duty	PRP
	Absolute air inlet pressure	100 kPa
	Relative air humidity	30%
	Air inlet temperature	25°C
<i>Limitations 1)</i>	Maximum ambient temperature	50°C
	Altitude capability	4000 m
	Maximum relative air humidity	< 100%
	Minimum starting temperature	-10°C
	Minimum starting temperature aided	NA
<i>Performance data 1) 2) 4)</i>	Rated active power (PRP) 3-phase	16 kW
	Rated active power (PRP) 1-phase	-
	Rated power factor (lagging) 3-phase	0.8
	Rated power factor (lagging) 1-phase	-
	Rated apparent power (PRP) 3-phase	20 kVA

Rated apparent power (PRP) 1-phase	-
Rated voltage 3-phase, line to line	400 V
Rated voltage 1-phase, line to line	-
Rated current 3-phase	28.9 A
Rated current 1-phase	-
Performance class (acc.ISO 8528-5:1993)	G2
Single step load acceptance (0-PRP)	16 kW
	100%
Frequency droop	< 5%
Fuel consumption at no load (0%)	0.93 kg/h
Fuel consumption at 50% load	2.38 kg/h
Fuel consumption at 75% load	3.13 kg/h
Fuel consumption at full load (100%)	4.00 kg/h
Specific fuel consumption	0.25 kg/kWh
Fuel autonomy at full load	16.3 h
Max. oil consumption at full load	0.014 l/h
Maximum sound power level (LWA) measured according to 2000/14/EC OND	
with metal canopy	93 dB(A)
with PE canopy (optional)	90 dB(A)
Capacity of fuel tank	80 l
Single step load capability	16 kW
	100%
Mode of operation	PRP
Site	land use
Operation	single
Start-up and control mode	manual/automatic (remote)
Start-up time	unspecified
Mobility/Config. acc. to ISO 8528-1:1993	transportable/D
(optional)	mobile/E
Mounting	fully resilient
Climatic exposure	open air
Status of neutral (ELR-config)	earthed
Status of neutral (IT-config)	insulated

Application data

<i>Alternator</i>	Standard	IEC 34-1 ISO 8528-5	
	Make	Leroy Somer	
	Model	LSA 40 M5	
	Rated output, class H temp. rise	20 kVA	
	Degree of protection	IP 23	
	Insulation stator class	H	
	Insulation rotor class	H	
	Number of wires	12	
	<i>Engine</i>	Standard	ISO 3046 ISO 8528-2
Type DEUTZ		F3M 2011 F	
Rated net output		19 kW	
Coolant		oil	
Combustion system		direct injection	
Aspiration		natural	
Number of cylinders		3 - in line	
Swept volume		2.33 l	
Speed governing		mechanical	
Capacity of oil sump		5.5 l	
Capacity of cooling system		8 l	
Electrical system		12 Vdc	
Emission compliance		EU Stage II	
<i>Power circuit</i>		Circuit-breaker, 3-phase	
		Number of poles	4
	Thermal release I_t (thermal release is higher at 25°C)	32 A	
	Magnetic release I_m	3..5xI _n	
	Fault current protection		
	Residual current release ID _n (ELR-config)	0.3 A	
	Insulation resistance (IT-config)	10-100 kOhm	

Unit

Outlet sockets

Dimensions with undercarriage (adj. with breaks) (LxWxH)
Dimensions with undercarriage (fixed with breaks) (LxWxH)
Dimensions without undercarriage (LxWxH)
Weight net mass - Box
Weight wet mass - Box
Weight net mass - Undercarriage AB
Weight wet mass - Undercarriage AB
Weight net mass - Undercarriage FB
Weight wet mass - Undercarriage FB

Domestic (1x)
2P + E
16 A 230 V
CEE form (1x)
3P + N + E
16 A 400 V
CEE form (1x)
3P + N + E
32 A 400 V
3562 x 1410 x 1258 mm
3160 x 1410 x 1258 mm
2016 x 1040 x 1019 mm
737 kg
804 kg
879 kg
946 kg
864 kg
931 kg

Notes

- 1) See derating diagram or consult the factory for other conditions.
- 2) At reference conditions unless otherwise stated.
- 3) Rating definition (ISO 8528-1):
 LTP: Limited Time Power is the maximum electrical power which a generating set is capable of delivering (at variable load), in the event of a utility power failure (for up to 500 hours per year of which a maximum of 300 hours is continuous running). No overload is permitted on these ratings. The alternator is peak continuous rated (as defined in ISO 8528-3) at 25°C.
 PRP: Prime Power is the maximum power available during a variable power sequence, which may be run for an unlimited number of hours per year, between stated maintenance intervals and under the stated ambient conditions. A 5% overload is permitted for 1 hour in 12 hours. The permissible average power output during a 24h period shall not exceed the stated load factor of 80%.
- 4) Specific mass fuel used: 0.86 kg/l.

Derating factor %

Height (m)	Temperature (°C)										
	0	5	10	15	20	25	30	35	40	45	50
0	100	100	100	100	100	100	97	95	92	89	86
500	100	100	98	97	95	94	91	89	86	83	81
1000	95	93	92	90	89	88	85	83	80	78	75
1500	88	87	85	84	83	81	79	77	75	72	70
2000	81	80	79	78	76	75	73	71	69	67	65
2500	74	73	72	71	70	69	67	65	63	61	59
3000	68	67	66	65	64	63	61	59	57	56	54
3500	61	60	59	58	57	56	55	53	52	50	49
4000	54	53	53	52	51	50	49	47	46	45	43

Technical specifications for QAX 24 Dd

Readings on gauges

<i>Gauge</i>	<i>Reading</i>	<i>Unit</i>
Ammeter L1 (P1)	Below max. rating	A
Voltmeter (P4)	Below max. rating	V

Settings of switches

<i>Switch</i>	<i>Function</i>	<i>Activates at</i>
Engine oil pressure	Shut down	0.5 bar
Engine coolant temperature	Shut down	105°C

Specifications of the engine/alternator/unit

		<i>240 V - 3-phase</i>
<i>Reference conditions 3)</i>	Rated frequency	60 Hz
	Rated speed	1800 rpm
	Generator service duty	PRP
	Absolute air inlet pressure	100 kPa
	Relative air humidity	30%
	Air inlet temperature	25°C
<i>Limitations 1)</i>	Maximum ambient temperature	50°C
	Altitude capability	4000 m
	Maximum relative air humidity	< 100%
	Minimum starting temperature	-10°C
	Minimum starting temperature aided	NA
<i>Performance data 1) 2) 4)</i>	Rated active power (PRP) 3-phase	19.8 kW
	Rated active power (PRP) 1-phase	-
	Rated power factor (lagging) 3-phase	0.8
	Rated power factor (lagging) 1-phase	-
	Rated apparent power (PRP) 3-phase	24.8 kVA

Rated apparent power (PRP) 1-phase	-
Rated voltage 3-phase, line to line	240 V
Rated voltage 1-phase, line to line	-
Rated current 3-phase	59.6 A
Rated current 1-phase	-
Performance class (acc.ISO 8528-5:1993)	G2
Single step load acceptance (0-PRP)	19.8 kW
	100%
Frequency droop	< 8%
Fuel consumption at no load (0%)	1.27 kg/h
Fuel consumption at 50% load	2.79 kg/h
Fuel consumption at 75% load	3.73 kg/h
Fuel consumption at full load (100%)	4.66 kg/h
Specific fuel consumption	0.27 kg/kWh
Fuel autonomy at full load	13.4 h
Max. oil consumption at full load	0.016 l/h
Maximum sound power level (LWA) measured according to 2000/14/EC OND	
with metal canopy	93 dB(A)
with PE canopy (only outside of USA)	90 dB(A)
Capacity of fuel tank	80 l
Single step load capability	19.8 kW
	100%
<i>Application data</i>	
Mode of operation	PRP
Site	land use
Operation	single
Start-up and control mode	manual/automatic (remote)
Start-up time	unspecified
Mobility/Config. acc. to ISO 8528-1:1993	transportable/D
(optional)	mobile/E
Mounting	fully resilient
Climatic exposure	open air
Status of neutral	earthed

<i>Alternator</i>	Standard	IEC 34-1
	Make	ISO 8528-5
	Model	Leroy Somer
	Rated output, class H temp. rise	LSA 40 M5
	Degree of protection	25 kVA
	Insulation stator class	IP 23
	Insulation rotor class	H
	Number of wires	H
<i>Engine</i>	Standard	12
	Type DEUTZ	ISO 3046
	Rated net output	ISO 8528-2
	Coolant	F3M 2011 F
	Combustion system	22.6 kW
	Aspiration	oil
	Number of cylinders	direct injection
	Swept volume	natural
	Speed governing	3 - in line
	Capacity of oil sump	2.33 l
	Capacity of cooling system	mechanical
	Electrical system	5.5 l
	Emission compliance	8 l
		12 Vdc
	Tier 2	
<i>Power circuit</i>	Circuit-breaker, 3-phase (only outside of USA)	
	Number of poles	4
	Thermal release I _t	63 A
	Magnetic release I _m	3..5xI _n

<i>Unit</i>	Fault current protection	
	Residual current release IDn (only outside of USA)	0.3 A
	Dimensions with undercarriage (adj. with breaks) (LxWxH)	3562 x 1410 x 1258 mm
	Dimensions with undercarriage (fixed with breaks) (LxWxH)	3160 x 1410 x 1258 mm
	Dimensions without undercarriage (LxWxH)	2016 x 1040 x 1019 mm
	Weight net mass - Box	737 kg
	Weight wet mass - Box	804 kg
	Weight net mass - Undercarriage AB	879 kg
	Weight wet mass - Undercarriage AB	946 kg
	Weight net mass - Undercarriage FB	864 kg
	Weight wet mass - Undercarriage FB	931 kg

Notes

- 1) See derating diagram or consult the factory for other conditions.
- 2) At reference conditions unless otherwise stated.
- 3) Rating definition (ISO 8528-1):
LTP: Limited Time Power is the maximum electrical power which a generating set is capable of delivering (at variable load), in the event of a utility power failure (for up to 500 hours per year of which a maximum of 300 hours is continuous running). No overload is permitted on these ratings. The alternator is peak continuous rated (as defined in ISO 8528-3) at 25°C.
PRP: Prime Power is the maximum power available during a variable power sequence, which may be run for an unlimited number of hours per year, between stated maintenance intervals and under the stated ambient conditions. A 5% overload is permitted for 1 hour in 12 hours. The permissible average power output during a 24h period shall not exceed the stated load factor of 80%.
- 4) Specific mass fuel used: 0.86 kg/l.

Derating factor %

Height (m)	Temperature (°C)										
	0	5	10	15	20	25	30	35	40	45	50
0	100	100	100	100	100	100	97	95	92	89	86
500	100	100	98	97	95	94	91	89	86	83	81
1000	95	93	92	90	89	88	85	83	80	78	75
1500	88	87	85	84	83	81	79	77	75	72	70
2000	81	80	79	78	76	75	73	71	69	67	65
2500	74	73	72	71	70	69	67	65	63	61	59
3000	68	67	66	65	64	63	61	59	57	56	54
3500	61	60	59	58	57	56	55	53	52	50	49
4000	54	53	53	52	51	50	49	47	46	45	43

Technical specifications for QAX 30 Dd

Readings on gauges

<i>Gauge</i>	<i>Reading</i>	<i>Unit</i>
Ammeter L3 (P1)	Below max. rating	A
Voltmeter (P4)	Below max. rating	V

Settings of switches

<i>Switch</i>	<i>Function</i>	<i>Activates at</i>
Engine oil pressure	Shut down	0.5 bar
Engine coolant temperature	Shut down	105°C

Specifications of the engine/alternator/unit

		<i>400 V - 3-phase</i>
<i>Reference conditions 3)</i>	Rated frequency	50 Hz
	Rated speed	1500 rpm
	Generator service duty	PRP
	Absolute air inlet pressure	100 kPa
	Relative air humidity	30%
	Air inlet temperature	25°C
<i>Limitations 1)</i>	Maximum ambient temperature	50°C
	Altitude capability	2500 m
	Maximum relative air humidity	< 85%
	Minimum starting temperature	-10°C
	Minimum starting temperature aided	NA
<i>Performance data 1) 2) 4)</i>	Rated active power (PRP) 3-phase	24 kW
	Rated active power (PRP) 1-phase	-
	Rated power factor (lagging) 3-phase	0.8
	Rated power factor (lagging) 1-phase	-

Rated apparent power (PRP) 3-phase	30 kVA
Rated apparent power (PRP) 1-phase	-
Rated voltage 3-phase, line to line	400 V
Rated voltage 1-phase, line to line	-
Rated current 3-phase	43.3 A
Rated current 1-phase	-
Performance class (acc.ISO 8528-5:1993)	G2
Single step load acceptance (0-PRP)	24 kW
	100%
Frequency droop	<5%
Fuel consumption at no load (0%)	1.02 kg/h
Fuel consumption at 50% load	3.26 kg/h
Fuel consumption at 75% load	4.60 kg/h
Fuel consumption at full load (100%)	6.08 kg/h
Specific fuel consumption	0.253 kg/kWh
Fuel autonomy at full load	11.3 h
Max. oil consumption at full load	0.034 l/h
Maximum sound power level (LWA) measured according to 2000/14/EC OND	
with metal canopy	91 dB(A)
with PE canopy (optional)	89 dB(A)
Capacity of fuel tank	80 l
Single step load capability (O-PRP)	24 kW
	100%
Mode of operation	PRP
Site	land use
Operation	single
Start-up and control mode	manual/automatic (remote)
Start-up time	unspecified
Mobility/Config. acc. to ISO 8528-1:1993	transportable/D
(optional)	mobile/E
Mounting	fully resilient
Climatic exposure	open air
Status of neutral (ELR-config)	earthed

Application data

<i>Alternator</i>	Status of neutral (IT-config)	insulated
	Standard	IEC34-1
	Make	ISO 8528-5
	Model	Leroy Somer
	Rated output, class H temp. rise	LSA 42.2 L9
	Degree of protection	31.5 kVA
	Insulation stator class	IP 23
	Insulation rotor class	H
	Number of wires	H
		12
<i>Engine</i>	Standard	ISO 3046
	Type DEUTZ	ISO 8528-2
	Rated net output	BF3M2011 F
	Coolant	27.6 kW
	Combustion system	oil
	Aspiration	direct injection
	Number of cylinders	turbocharged
	Swept volume	3 - in line
	Speed governing	2.33 l
	Capacity of oil sump	mechanical
	Capacity of cooling system	5.5 l
	Electrical system	8 l
	Emission compliance	12 Vdc
		EU stage II
<i>Power circuit</i>	Circuit-breaker, 3-phase	
	Number of poles	4
	Thermal release I _t (thermal release is higher at 25°C)	50 A
	Magnetic release I _m	3..5xI _n
	Fault current protection	
	Residual current release ID _n (ELR-config)	0.3A

Unit

Insulation resistance (IT-config)	10-100 kOhm
Outlet sockets	Domestic (1x) 2P + E 16 A 230 V
	CEE form (1x) 3P + N + E 16 A or 32 A 400 V
	CEE form (1x) 3P + N + E 63 A 400 V
Dimensions with undercarriage (adj. with breaks) (LxWxH)	3562 x 1410 x 1258 mm
Dimensions with undercarriage (fixed with breaks) (LxWxH)	3160 x 1410 x 1258 mm
Dimensions without undercarriage (LxWxH)	2016 x 1040 x 1019 mm
Weight net mass - Box	737 kg
Weight wet mass - Box	804 kg
Weight net mass - Undercarriage AB	879 kg
Weight wet mass - Undercarriage AB	946 kg
Weight net mass - Undercarriage FB	864 kg
Weight wet mass - Undercarriage FB	931 kg

Notes

- 1) See derating diagram or consult the factory for other conditions.
- 2) At reference conditions unless otherwise stated.
- 3) Rating definition (ISO 8528-1):
 LTP: Limited Time Power is the maximum electrical power which a generating set is capable of delivering (at variable load), in the event of a utility power failure (for up to 500 hours per year of which a maximum of 300 hours is continuous running). No overload is permitted on these ratings. The alternator is peak continuous rated (as defined in ISO 8528-3) at 25°C.
 PRP: Prime Power is the maximum power available during a variable power sequence, which may be run for an unlimited number of hours per year, between stated maintenance intervals and under the stated ambient conditions. A 5% overload is permitted for 1 hour in 12 hours. The permissible average power output during a 24h period shall not exceed the stated load factor of 80%.
- 4) Specific mass fuel used: 0.86 kg/l.

Derating factor %

Height (m)	Temperature (°C)										
	0	5	10	15	20	25	30	35	40	45	50
0	100	100	100	100	100	100	100	97	95	92	90
500	100	100	100	100	100	100	100	97	95	92	90
1000	100	100	100	100	100	100	100	96	93	89	86
1500	100	100	100	100	98	96	93	89	86	83	80
2000	100	100	98	96	93	90	87	84	81	77	75
2500	99	97	94	91	88	85	82	80	77	74	71

Technical specifications for QAX 35 Dd

Readings on gauges

<i>Gauge</i>	<i>Reading</i>	<i>Unit</i>
Ammeter L1 (P1)	Below max. rating	A
Voltmeter (P4)	Below max. rating	V

Settings of switches

<i>Switch</i>	<i>Function</i>	<i>Activates at</i>
Engine oil pressure	Shut down	0.5 bar
Engine coolant temperature	Shut down	105°C

Specifications of the engine/alternator/unit

		<i>240 V - 3-phase</i>
<i>Reference conditions 3)</i>	Rated frequency	60 Hz
	Rated speed	1500 rpm
	Generator service duty	PRP
	Absolute air inlet pressure	100 kPa
	Relative air humidity	30%
	Air inlet temperature	25°C
<i>Limitations 1)</i>	Maximum ambient temperature	50°C
	Altitude capability	2500 m
	Maximum relative air humidity	< 85%
	Minimum starting temperature	-10°C
	Minimum starting temperature aided	NA
<i>Performance data 1) 2) 4)</i>	Rated active power (PRP) 3-phase	29.2 kW
	Rated active power (PRP) 1-phase	-
	Rated power factor (lagging) 3-phase	0.8
	Rated power factor (lagging) 1-phase	-

Rated apparent power (PRP) 3-phase	36.5 kVA
Rated apparent power (PRP) 1-phase	-
Rated voltage 3-phase, line to line	240 V
Rated voltage 1-phase, line to line	-
Rated current 3-phase	87.7 A
Rated current 1-phase	-
Performance class (acc.ISO 8528-5:1993)	G2
Single step load acceptance (0-PRP)	29.2 kW
	100%
Frequency droop	< 5%
Fuel consumption at no load (0%)	1.55 kg/h
Fuel consumption at 50% load	4.02 kg/h
Fuel consumption at 75% load	5.68 kg/h
Fuel consumption at full load (100%)	7.44 kg/h
Specific fuel consumption	0.255 kg/kWh
Fuel autonomy at full load	9.5 h
Max. oil consumption at full load	0.042 l/h
Maximum sound power level (LWA) measured according to 2000/14/EC OND	
with metal canopy	92 dB(A)
with PE canopy (optional)	90 dB(A)
Capacity of fuel tank	80 l
Single step load capability (O-PRP)	29.2 kW
	100%
<i>Application data</i>	
Mode of operation	PRP
Site	land use
Operation	single
Start-up and control mode	manual/automatic (remote)
Start-up time	unspecified
Mobility/Config. acc. to ISO 8528-1:1993	transportable/D
(optional)	mobile/E
Mounting	fully resilient
Climatic exposure	open air
Status of neutral	earthed

<i>Alternator</i>	Standard	IEC34-1
		ISO 8528-5
	Make	Leroy Somer
	Model	LSA 42.2 L9
	Rated output, class H temp. rise	38 kVA
	Degree of protection	IP 23
	Insulation stator class	H
	Insulation rotor class	H
<i>Engine</i>	Number of wires	12
	Standard	ISO 3046
		ISO 8528-2
	Type DEUTZ	BF3M2011 F
	Rated net output	32.4 kW
	Coolant	oil
	Combustion system	direct injection
	Aspiration	turbocharged
	Number of cylinders	3 - in line
	Swept volume	2.33 l
	Speed governing	mechanical
	Capacity of oil sump	5.5 l
	Capacity of cooling system	8 l
	Electrical system	12 Vdc
Emission compliance	NA	
<i>Power circuit</i>	Circuit-breaker, 3-phase	
	Number of poles	4
	Thermal release I _t (thermal release is higher at 25°C)	100 A
	Magnetic release I _m	3..5xI _n
	Fault current protection	
	Residual current release ID _n	0.3 A

<i>Unit</i>	Dimensions with undercarriage (adj. with breaks) (LxWxH)	3562 x 1410 x 1258 mm
	Dimensions with undercarriage (fixed with breaks) (LxWxH)	3160 x 1410 x 1258 mm
	Dimensions without undercarriage (LxWxH)	2016 x 1040 x 1019 mm
	Weight net mass - Box	737 kg
	Weight wet mass - Box	804 kg
	Weight net mass - Undercarriage AB	879 kg
	Weight wet mass - Undercarriage AB	946 kg
	Weight net mass - Undercarriage FB	864 kg
	Weight wet mass - Undercarriage FB	931 kg

Notes

- 1) See derating diagram or consult the factory for other conditions.
- 2) At reference conditions unless otherwise stated.
- 3) Rating definition (ISO 8528-1):
LTP: Limited Time Power is the maximum electrical power which a generating set is capable of delivering (at variable load), in the event of a utility power failure (for up to 500 hours per year of which a maximum of 300 hours is continuous running). No overload is permitted on these ratings. The alternator is peak continuous rated (as defined in ISO 8528-3) at 25°C.
PRP: Prime Power is the maximum power available during a variable power sequence, which may be run for an unlimited number of hours per year, between stated maintenance intervals and under the stated ambient conditions. A 5% overload is permitted for 1 hour in 12 hours. The permissible average power output during a 24h period shall not exceed the stated load factor of 80%.
- 4) Specific mass fuel used: 0.86 kg/l.

Derating factor %

Height (m)	Temperature (°C)										
	0	5	10	15	20	25	30	35	40	45	50
0	100	100	100	100	100	100	100	97	95	92	90
500	100	100	100	100	100	100	100	97	95	92	90
1000	100	100	100	100	100	100	100	96	93	89	86
1500	100	100	100	100	98	96	93	89	86	83	80
2000	100	100	98	96	93	90	87	84	81	77	75
2500	99	97	94	91	88	85	82	80	77	74	71

Torque values

For general applications

The following tables list the recommended torques applied for general applications at assembly of the generator.

For hexagon screws and nuts with strength grade 8.8:

Thread size	M6	M8	M10	M12	M14	M16
Nm	9	23	46	80	125	205

For hexagon screws and nuts with strength grade 12.9:

Thread size	M6	M8	M10	M12	M14	M16
Nm	15	39	78	135	210	345

For important assemblies

Assemblies	Unit	Torque values
Wheel nuts	Nm	80 + 10/- 0
Bolts, axle/beams	Nm	80 ± 10
Bolts, towbar/axle	Nm	80 ± 10
Bolts, towbar/bottom	Nm	80 ± 10
Bolts, towing eye/towbar	Nm	80 ± 10
Bolts, lifting eye/flywheel housing	Nm	205 + 20
Bolts, engine/drive housing (M12)	Nm	80 ± 10
Bolts, engine/drive housing (M14)	Nm	125 ± 10
Lifting beam	Nm	40 ± 10
Safety switches	Nm	35 ± 5
Joints adjustable towbar M24	Nm	275 ± 25
Joints adjustable towbar M32	Nm	375 ± 25



Secure the tank cap and drain plug of the fuel tank handtight.

Conversion list of SI units into British units

1 bar	=	14.504 psi
1 g	=	0.035 oz
1 kg	=	2.205 lb
1 km/h	=	0.621 mile/h
1 kW	=	1.341 hp (UK and US)
1 l	=	0.264 US gal
1 l	=	0.220 Imp gal (UK)
1 l	=	0.035 cu.ft
1 m	=	3.281 ft
1 mm	=	0.039 in
1 m ³ /min	=	35.315 cfm
1 mbar	=	0.401 in wc
1 N	=	0.225 lbf
1 Nm	=	0.738 lbf.ft
t°F	=	32 + (1.8 x t°C)
t°C	=	(t°F - 32)/1.8

A temperature difference of 1°C = a temperature difference of 1.8°F.

Dataplate

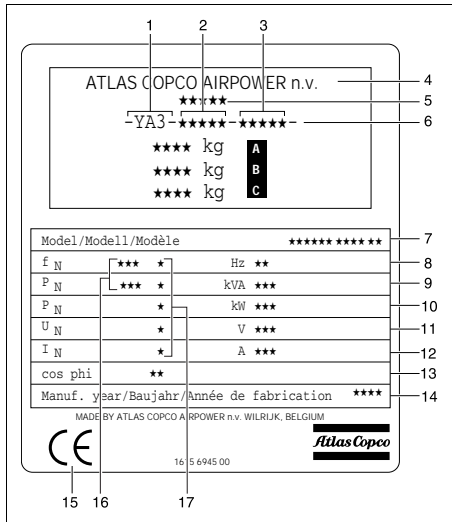

- A | Maximum permitted total weight of the vehicle
- B | Maximum permitted axle load
- C | Maximum permitted towing eye load
- 1 | Company code
- 2 | Product code
- 3 | Unit serial number
- 4 | Name of manufacturer
- 5 | EEC or national type approved number
- 6 | Vehicle identification number
- 7 | Model number
- 8 | Frequency
- 9 | Apparant power - PRP
- 10 | Active power - PRP
- 11 | Nominal rated voltage
- 12 | Nominal rated current
- 13 | Power factor
- 14 | Manufacturing year
- 15 | EEC mark in accordance with Machine Directive 89/392E
- 16 | Mode of operation
- 17 | Winding connections

Disposal

General

When developing products and services, Atlas Copco tries to understand, address, and minimize the negative environmental effects that the products and services may have, when being manufactured, distributed, and used, as well as at their disposal.

Recycling and disposal policy are part of the development of all Atlas Copco products. Atlas Copco company standards determine strict requirements.

Selecting materials the substantial recyclability, the disassembly possibilities and the separability of materials and assemblies are considered as well as the environmental perils and dangers to health during the recycling and disposal of the unavoidable rates of not recyclable materials.

Your Atlas Copco generator consists for the most part of metallic materials, that can be remelted in steelworks and smelting works and that is therefore almost infinite recyclable. The plastic used is labelled; sorting and fractioning of the materials for recycling in the future is foreseen.



This concept can only succeed with your help. Support us by disposing professionally. By assuring a correct disposal of the product you help to prevent possible negative consequences for environment and health, that can occur with an inappropriate waste handling.

Recycling and re-usage of material helps to preserve natural resources.

Disposal of materials

Dispose contaminated substances and material separately, according to local applicable environmental legislations.

Before dismantling a machine at the end of its operating lifetime drain all fluids and dispose of according the applicable local disposal regulations.

Remove the batteries. Do not throw batteries into the fire (explosion risk) or into the residual waste. Separate the machine into metal, electronics, wiring, hoses, insulation and plastic parts.

Dispose all components according to the applicable disposal regulations.

Remove spilled fluid mechanically; pick up the rest with absorbing agent (for example sand, sawdust) and dispose it according the applicable local disposal regulations. Do not drain into the sewage system or surface water.

Circuit diagrams

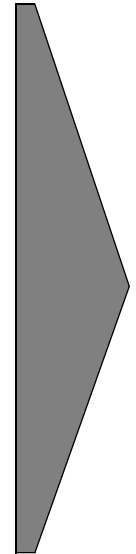

9822 0997 32/00

Applicable for QAX 24-35 Dd - 3-phase - Power Circuit

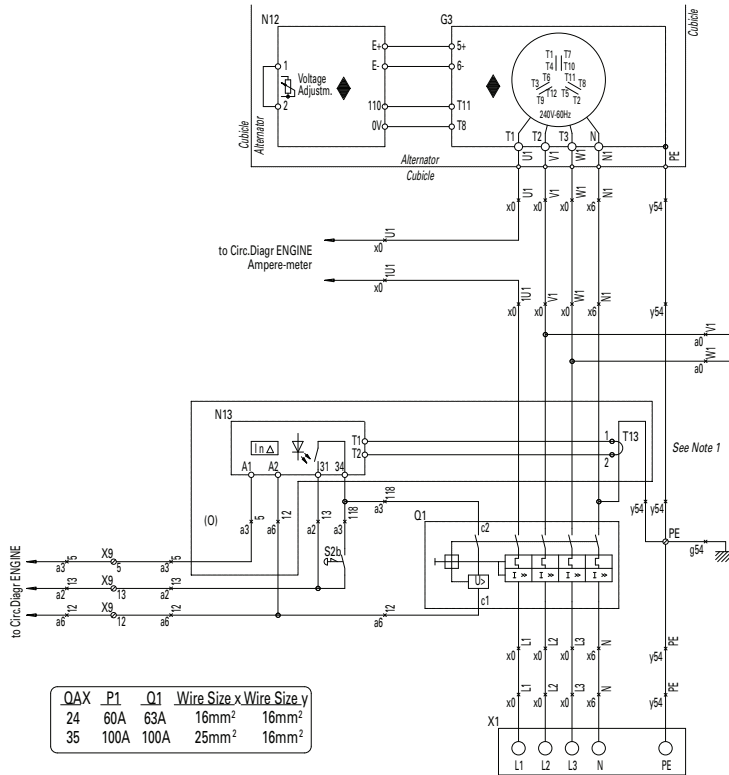

QAX	P1	Q1	Wire Size x	Wire Size y
24	60A	63A	16mm ²	16mm ²
35	100A	100A	25mm ²	16mm ²

Legend

Wire size :

- a = 1 mm²
- b = 1.5mm²
- c = 2.5mm²
- d = 4 mm²
- e = 6 mm²
- f = 10 mm²
- g = 16 mm²
- h = 25 mm²
- i = 35 mm²
- j = 50 mm²
- k = 70 mm²
- lx = 95 mm² ERP-CSP (BS6195-4C)
- bx = 1.5 mm² NSGAFOeU

Colour code :

- 0 = black
- 1 = brown
- 2 = red
- 3 = orange
- 4 = yellow
- 5 = green
- 6 = blue
- 7 = purple
- 8 = grey
- 9 = white
- 54 = green/yel.

Notes

Note 1: The PE-N connection has to be made at the alternator-side of main Circuit Breaker Q1.



F1-F2	Fuses 4 A
G3	Alternator
N12	Automatic voltage regulator
N13	Earth leakage relay
Q1	Circuit breaker
S2b	Emergency stop (S2a: see engine circuit)
T13	Torus earth leakage
X1	Terminal board
X9	Terminal strip
(O)	Optional equipment

9822 0997 35/00

Applicable for QAX 12-20-30 Dd - 3-phase - Power Circuit

QAX	P1	Q1	X1	Q2/X2	Wire Size x	Wire Size y
12	0-30A	20A	32A	16A	2.5mm ²	2.5mm ²
20	0-30A	32A	32A	16A	6mm ²	2.5mm ²
30	0-60A	50A	63A	16A(32A*)	10mm ²	2.5mm ² (6mm ² /*)

(*)-X2 optional on QAX30

(*)-X2 optional on QAX30

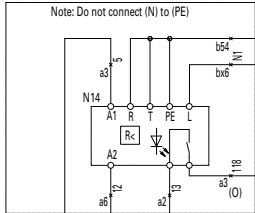
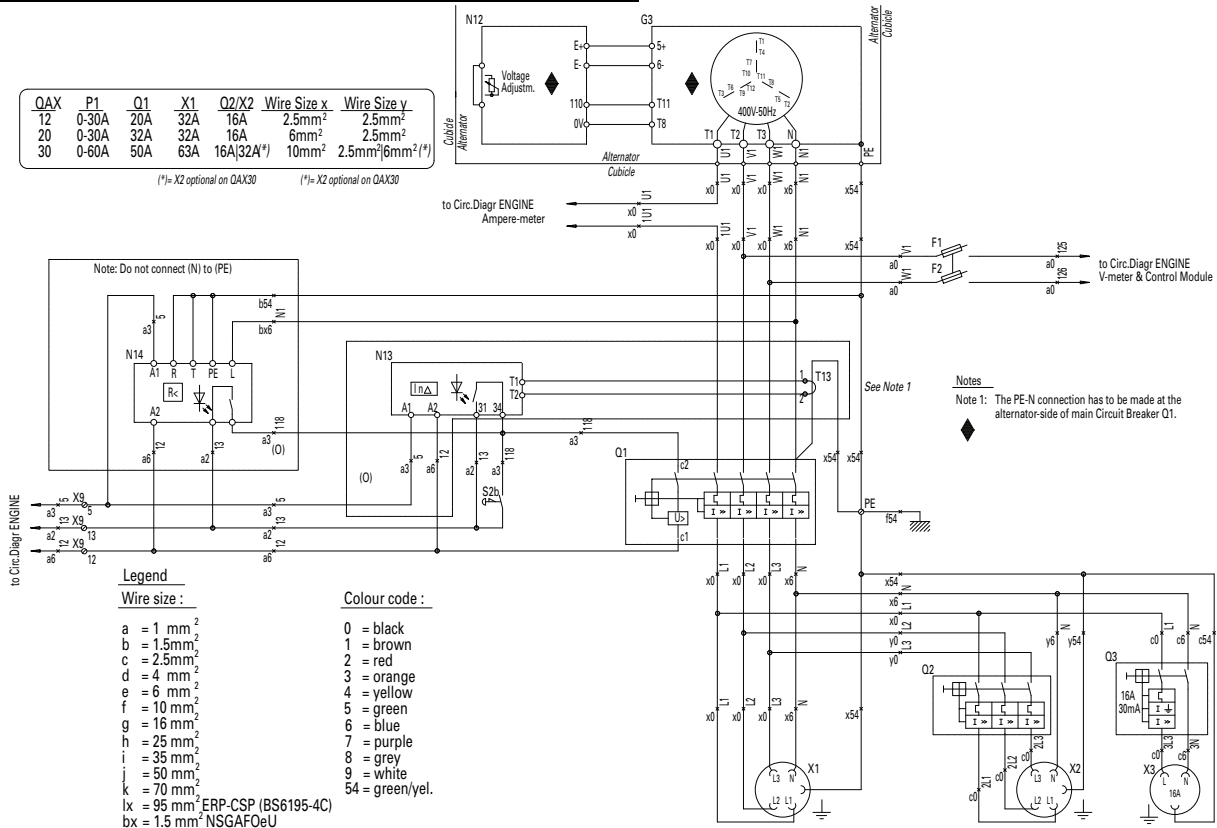

Legend

Wire size :

- a = 1 mm²
- b = 1.5mm²
- c = 2.5mm²
- d = 4 mm²
- e = 6 mm²
- f = 10 mm²
- g = 16 mm²
- h = 25 mm²
- i = 35 mm²
- j = 50 mm²
- k = 70 mm²
- lx = 95 mm² ERP-CSP (BS6195-4C)
- bx = 1.5 mm² NSGAF0eU

Colour code :

- 0 = black
- 1 = brown
- 2 = red
- 3 = orange
- 4 = yellow
- 5 = green
- 6 = blue
- 7 = purple
- 8 = grey
- 9 = white
- 54 = green/yel.

Notes

Note 1: The PE-N connection has to be made at the alternator-side of main Circuit Breaker O1.

F1-F2	Fuses 4 A
G3	Alternator
N12	Automatic voltage regulator
N13	Earth leakage relay (O)
N14	IT-relay (O)
Q1	Circuit breaker
Q2	Circuit breaker
Q3	Circuit breaker 16 A/30 mA
S2b	Emergency stop (S2a: see engine circuit)
T13	Torus earth leakage (O)
X1	Outlet socket
X2	Outlet socket
X3	Outlet socket 16 A (1P+N)
X9	Terminal strip
(O)	Optional equipment

9822 0997 36/00

Applicable for QAX 12 Dd - 1-phase - Power Circuit

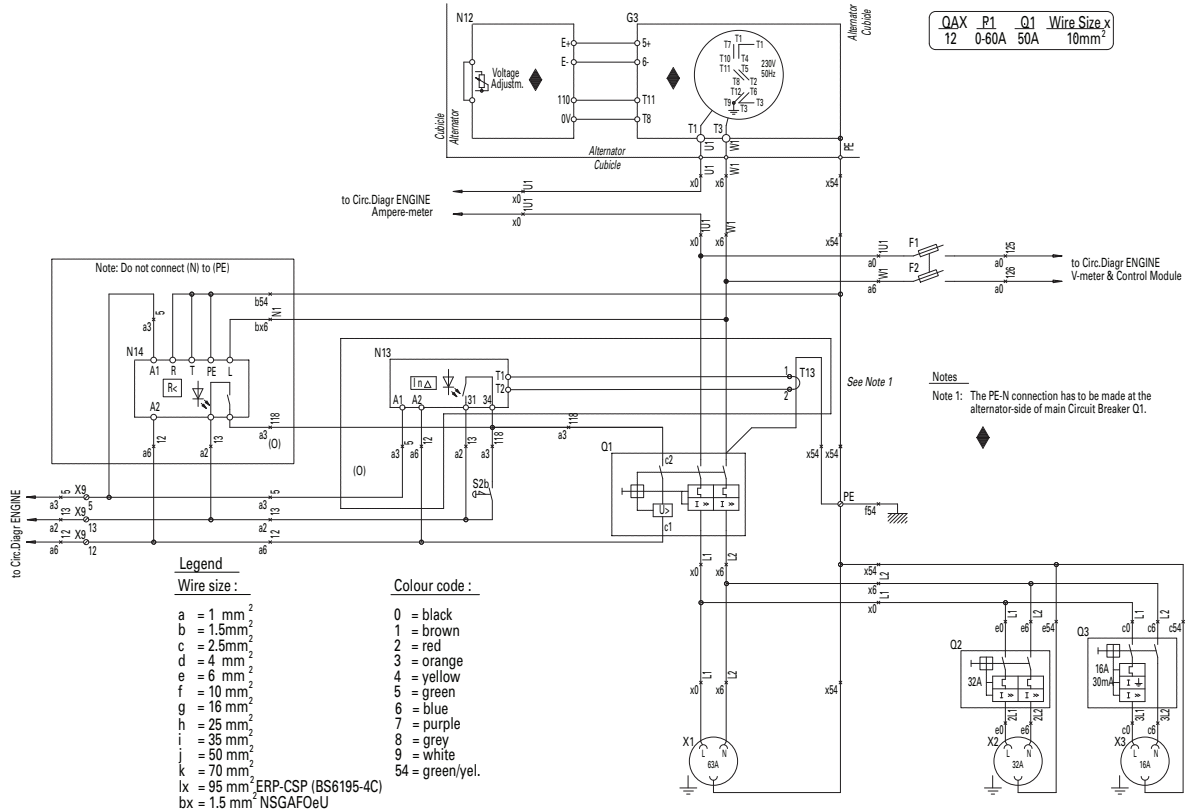

F1-F2	Fuses 4 A
G3	Alternator
N12	Automatic voltage regulator
N13	Earth leakage relay (O)
N14	IT relay (O)
Q1	Circuit breaker
Q2	Circuit breaker 32 A
Q3	Circuit breaker 16 A/30 mA
S2b	Emergency stop (S2a: see engine circuit)
S13	Earth leakage disable switch (O)
T13	Torus earth leakage (O)
X1	Outlet socket 63 A
X2	Outlet socket 32 A
X3	Outlet socket 16 A (IP+N)
X9	Terminal strip
(O)	Optional equipment

9822 0997 83/04

Applicable for QAX 12-20-24-30-35 Dd - Qc1002™

- A1 Generator control unit
(set A1 in unit-type 4)
- F10 Fuse 10 A
- G1 Battery 12 Vdc
- G2 Charging alternator
- K0 Starter solenoid
- K4 W/L-inverter relay
- K5 Starter relay
- M1 Starter motor
- P1 Amperemeter
- P4 Voltmeter
- R2 Excitation resistor 47 Ohm
- S2a Emergency stop
(S2b: see Power Circuit)
- S8 High coolant temperature switch
- S9 Low oil pressure switch
- S20 On/Off/Remote switch
- V2 Excitation diode
- X10 Connector wire harness
- X25 Customer's terminal strip
- Y1 Fuel stop solenoid

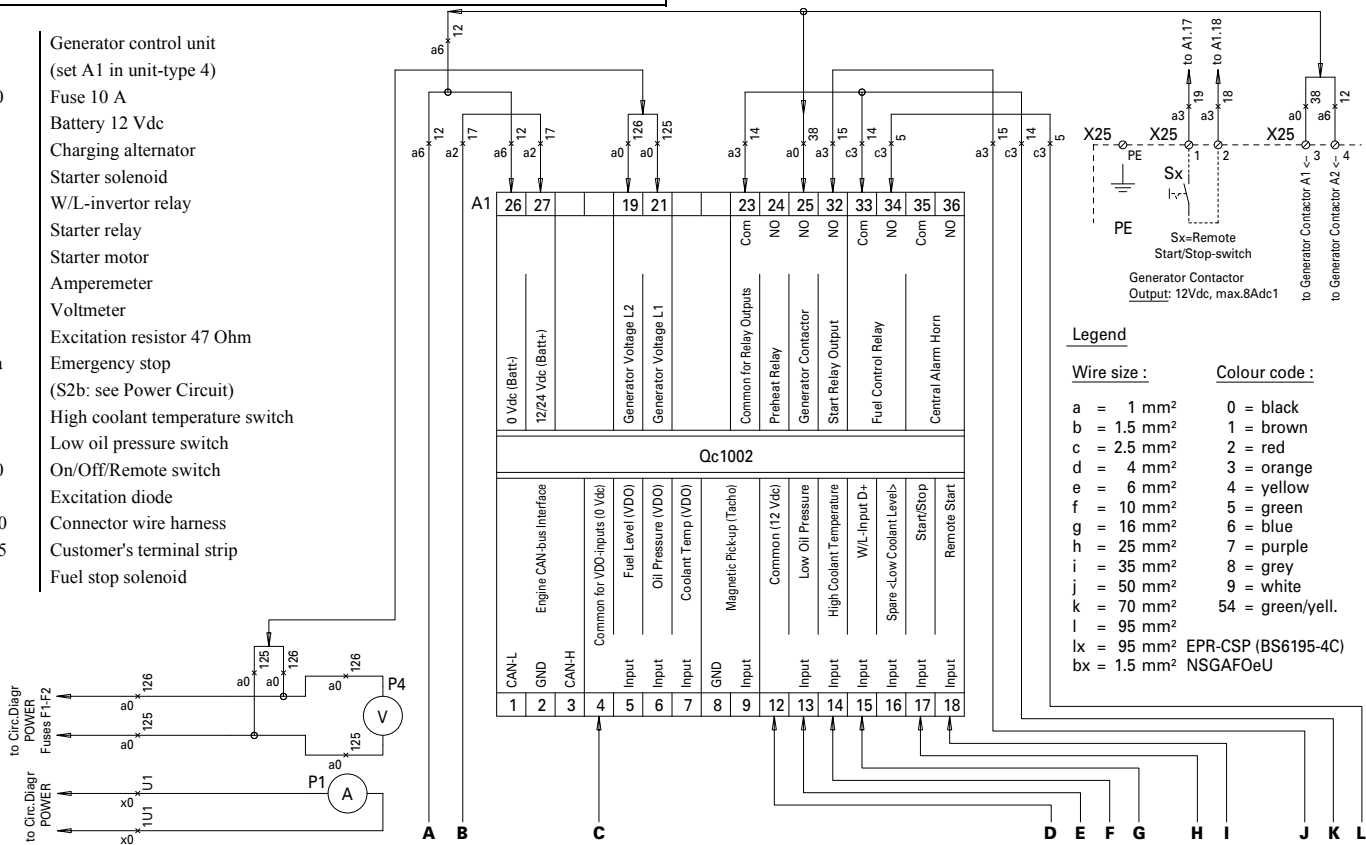

Legend

Wire size :

Colour code :

- a = 1 mm²
- b = 1.5 mm²
- c = 2.5 mm²
- d = 4 mm²
- e = 6 mm²
- f = 10 mm²
- g = 16 mm²
- h = 25 mm²
- i = 35 mm²
- j = 50 mm²
- k = 70 mm²
- l = 95 mm²
- lx = 95 mm² EPR-CSP (BS6195-4C)
- bx = 1.5 mm² NSGAFOeU
- 0 = black
- 1 = brown
- 2 = red
- 3 = orange
- 4 = yellow
- 5 = green
- 6 = blue
- 7 = purple
- 8 = grey
- 9 = white
- 54 = green/yell.

Position of Relay Contacts

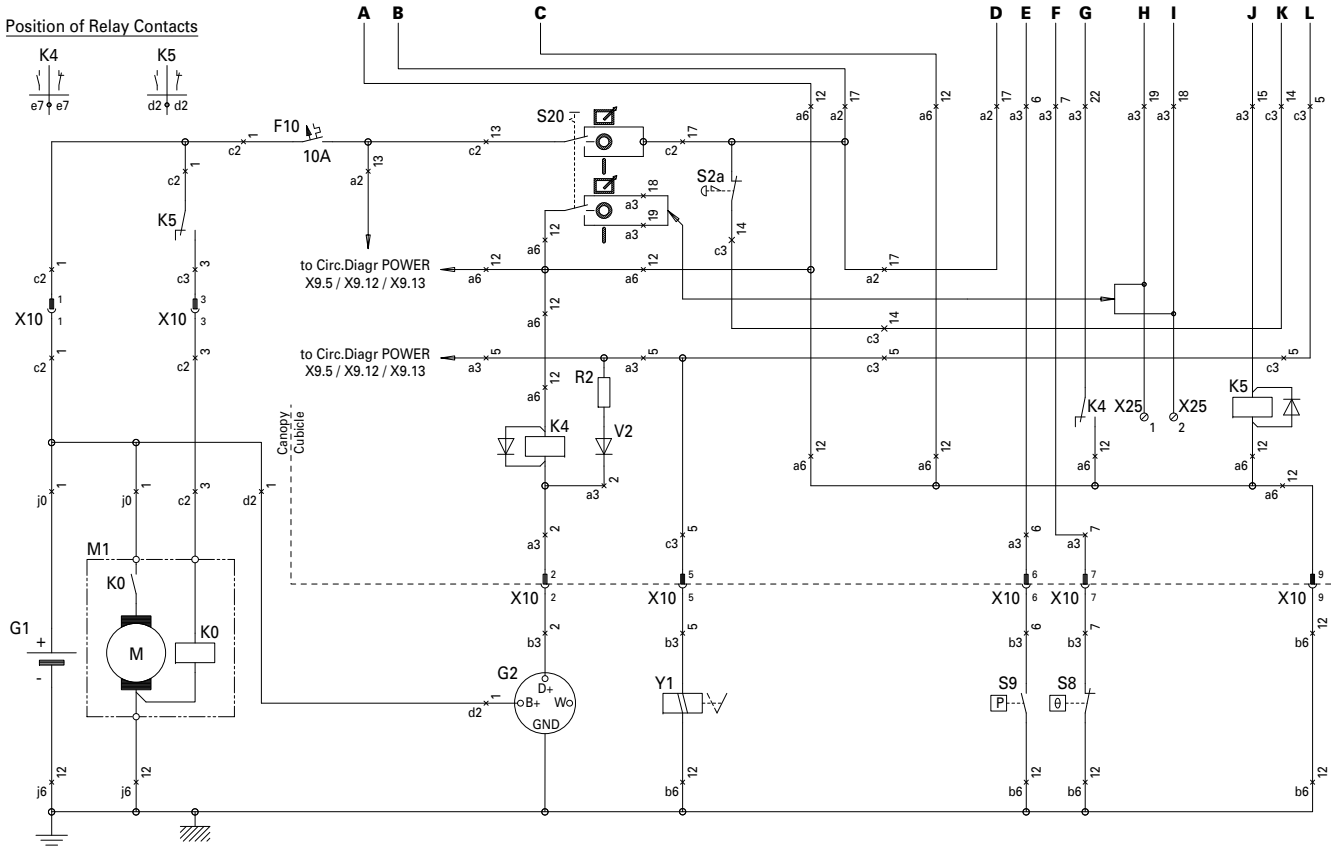

Following documents are provided with this unit:

- Test Certificate
- EC Declaration of Conformity:



EC DECLARATION OF CONFORMITY

1 We, Atlas Copco Airpower n.v., declare under our sole responsibility, that the product

2 Machine name : **Power generator (< 400 kW)**

3 Commercial name :

4 Serial number :

5 Which falls under the provisions of article 12.2 of the EC Directive 2006/42/EC on the approximation of the laws of the Member States relating to machinery, is in conformity with the relevant Essential Health and Safety Requirements of this directive.

The machinery complies also with the requirements of the following directives and their amendments as indicated:

Directive on the approximation of laws of the Member States relating to	Harmonized and/or Technical Standards used	Att: ment
Machinery safety	2006/42/EC EN ISO 12100-1 EN ISO 12100-2 EN 10123-1	
Electromagnetic compatibility	2004/108/EC EN 61000-6-2 EN 61000-6-4	
Low voltage equipment	2006/95/EC EN 60334 EN 60204-1 EN 60439	
Outdoor noise emission	2000/14/EC ISO 3744	x

66 The harmonized and the technical standards used are identified in the attachments hereafter

67 Atlas Copco Airpower n.v. is authorized to compile the technical file

68 **Conformity of the specification to the Directives**

69 Issued by : Product engineering

70 Name :

71 Signature :

72 Place , Date :

73 **Conformity of the product to the specification and by implication to the directives**

74 Manufacturing

Form No. 00001006.03
01-01-2006 10:00:00

Atlas Copco Airpower n.v. A company within the Atlas Copco Group

Postal address Visitors address Phone: +32 (0)3 870 21 11 Com. Reg. Antwerp 44651

P.O. Box 100 Boompsteennweg 957 Fax: +32 (0)3 870 24 43 V.A.T. 403.992.231

B-2010 Willebroek-Antwerp B-2010 Willebroek-Antwerp

Belgium Belgium For info, please contact your local Atlas Copco representative

www.atlascopco.com

p.1/2



www.atlascopco.com

Printed in Belgium 06/2010 - 2954 3490 02