



- AUS
- CAN
- GB
- IRL
- NZ
- USA

Operation, Maintenance, Safety

Operating instructions for the belt sanding machine

HUMMEL

Lägler

WORLD LEADERS IN FLOOR
SANDING TECHNOLOGY

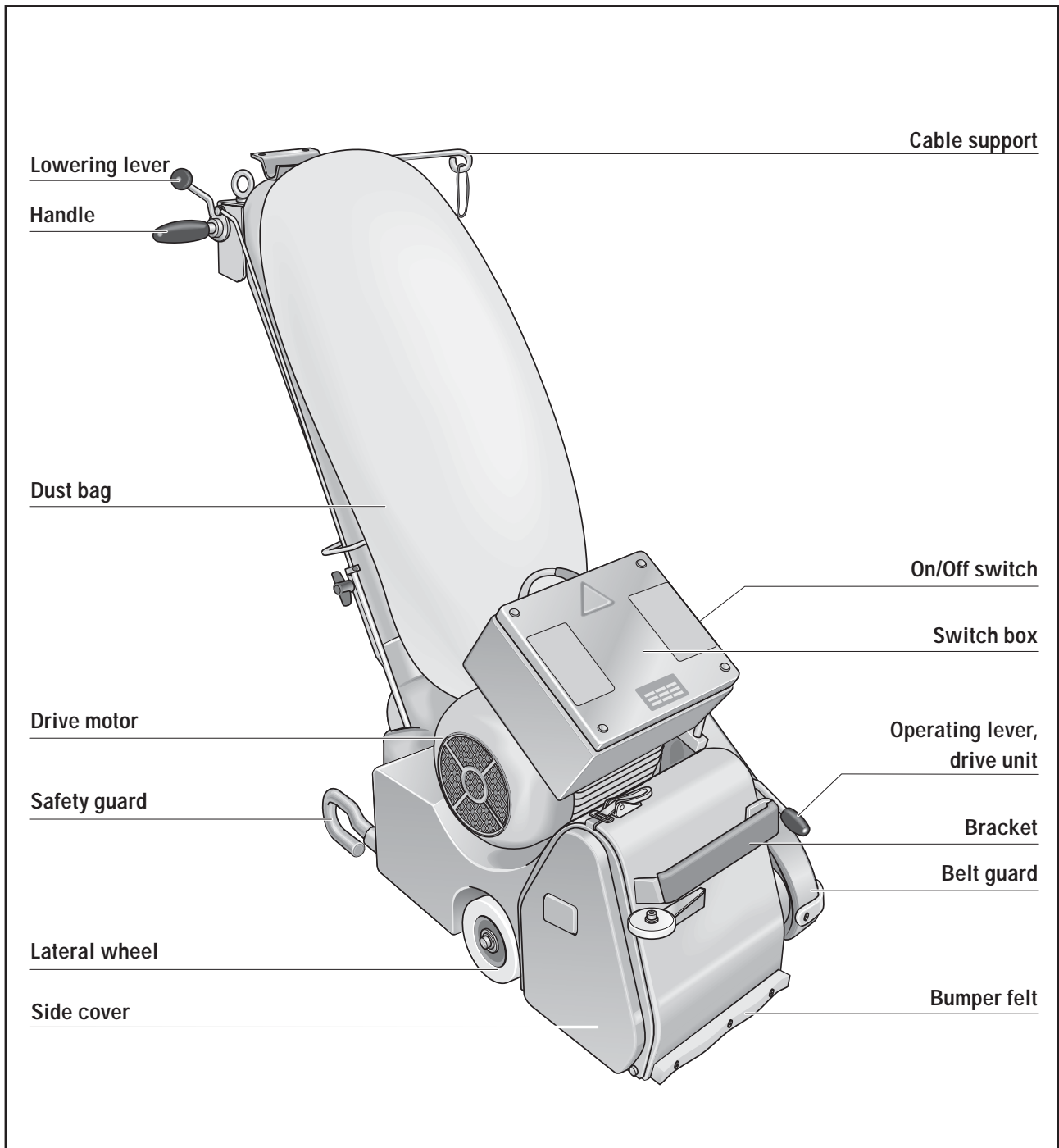

Fig. 1 Assemblies of the HUMMEL belt sanding machine

CONTENTS

1.	Introduction.....	4
1.1	Features of the machine	4
1.2	Description of the machine	4
1.3	Intended use of the machine	4
1.4	Danger warnings	5
1.5	Safety devices	6
2.	Technical data	6
3.	Commissioning.....	8
3.1	Preparing the machine for operation	8
3.2	Starting the machine.....	10
3.3	Switching off the machine.....	10
4.	Working with the HUMMEL	11
4.1	Application tips.....	11
4.2	Changing the sanding belt.....	12
4.3	Regulating the sanding drum pressure	13
4.4	Emptying the dust bag.....	13
5.	Transport and storage.....	14
5.1	Dismantling the machine	14
5.2	Assembly after transportation	15
5.3	Storage	15
6.	Maintenance.....	16
6.1	Cleaning and care instructions.....	16
6.2	Lubrication	18
6.3	Checking sanding belt regulation	18
6.4	Checking the machine setting.....	19
6.5	Checking the dust pick-up.....	21
6.6	Replacement of wearing parts.....	21
6.7	Regular maintenance and testing in accordance with accident prevention regulations	26
7.	Troubleshooting	27
8.	General safety remarks	28
9.	Circuit diagram	31
10.	Spare parts.....	34
11.	Service passport	47
12.	Declaration of conformity.....	48

Introduction

You are now the owner of a high-quality product from LÄGLER. We wish you every success with the HUMMEL. This machine has been manufactured using state-of-the-art production techniques. All LÄGLER products are subjected to thorough controls before they leave the factory.

Please read right through these operating instructions before working with the HUMMEL for the first time. The operating instructions contain important information relating to working safety and will answer many of your questions, permitting you to work confidently and safely with the machine. If you require information which is not provided in these instructions, refer to your sanding manual or consult our Customer Services Department, which will be pleased to advise you. Our fully trained and qualified service technicians are highly familiar with the HUMMEL and will be able to provide any assistance you may need.

The belt sanding machine HUMMEL is only usable for dry processing. Never use your HUMMEL for wet processing (Danger!).

1.1 FEATURES OF THE MACHINE

Fig. 1 (page 2) shows the most important assemblies which make up the HUMMEL. We recommend that you take some time to become familiar with the machine.

1.2 DESCRIPTION OF THE MACHINE

The HUMMEL belt sanding machine operates with a contact sanding drum featuring a specially profiled rubber coating. The belt tensioning fixture with integrated automatic belt guidance is located vertically above the sanding drum. The work zone is covered by the machine housing and detachable side cover. On the machine housing, the electric motor is fixed in a motor bearing bracket. The plug for connection to the mains is located at the switch box of the motor. The motor switch with the switch positions START / WORKING and TEST is located at the switch box. On the left under the belt guard is the belt drive unit. The machine is moved by means of a steering wheel at the back and two lateral wheels. Two handles are attached to the guide tube, where the drum lowering lever is also located and the cables and dust bag are attached.

The HUMMEL belt sanding machine is intended for dry use only. Never attempt to use the HUMMEL for any wet process (risk of fatal accidents)!

1.3 INTENDED USE OF THE MACHINE

The HUMMEL belt sanding machine is suitable for sanding wooden and cork floors, plastic skating rinks and tartan running tracks. A specially equipped version of the machine can be used to sand sheet metal surfaces.

Any application other than that described here is inadmissible without the consent of the manufacturer. Never use for wet sanding processes!

1.4 DANGER WARNINGS

Read through the danger warnings carefully and instruct your employees or colleagues accordingly. Failure to comply with this requirement could result in danger of injury.

In order to avoid injury caused by the sanding belt, the machine may never be switched on when tilted backward.

Use only tools, accessories and spares intended for the HUMMEL supplied by LÄGLER. **No warranty cover exists for parts sourced from other manufacturers!** Use of other parts can result in damage to the machine, to the floor you are sanding, or injury to the machine operator.

Ensure that the dust bag is correctly attached in order to prevent the unnecessary release of dust. This contaminates the environment and constitutes a health hazard to operating personnel.

Incorrect transportation will result in damage to the equipment.

To avoid fire or explosive damage, always remove the dust bag from the machine following sanding and empty the contents into a non-combustible container! Seal this container with a non-combustible cover and always store both the container and the dust bag in the open!

Keep well away from sources of fire.

Do not smoke when there is dust in the atmosphere (e.g. while working with the machine or emptying out the dust) → this could cause a dust explosion.

The mains connection cable must be kept out of the work area in order to prevent mechanical or electrical damage.

In order to prevent any chance of the machine being unintentionally started up, the power supply must be cut off when the machine is switched off by unplugging from the mains!

To protect the equipment against current faults, we advise using a DI safety plug (Art. no. in *Section 10*).

When the unit is operated correctly, the prescribed dust limit values are adhered to. When emptying the dust bag, we recommend wearing respiratory protection mask P3 (Art. no. in *Section 10*).

1.5 SAFETY DEVICES

The following parts of the machine are safety devices and must accordingly be kept in perfect working order:

Sealing felt	=	Dust shield
Side cover	=	Dust shield, sanding belt protection
Machine housing	=	Sanding belt protection
Belt guard	=	V-belt protection

Technical data

Note on noise emission:

The specified values are emission values and are not required to constitute safe workplace levels. Although a correlation does exist between emission and imission levels, it is not possible to conclude on this basis whether additional precautionary measures are necessary. Factors which influence the current imission level existing at the workplace include the duration of exposure, the character of the workroom, other noise sources such as the number of machines and other adjacent machining processes. The admissible workplace values can also vary from one country to another. However, this information is provided in order to enable the user to better estimate the level of danger and risk.

Note:

The motor data mentioned above relates to machines used in the Federal Republic of Germany. Different data may apply to exported machines. This is indicated on the motor rating plate.

Manufacturer.....	Eugen LÄGLER GmbH
Machine type.....	Belt sanding machine
Serial number	see rating plate
Year of construction.....	see rating plate
Motor type.....	single-phase AC motor
Voltage	230 V
Frequency	50 Hz
Output	2.2 kW
Fusing	16 A
Insulation class	B
Protection rating	IP 54
Safety devices	no-voltage release
.....	thermal switch as overload
.....	protection in the motor
Starting capacitor	60 µF
Operating capacitor	40 µF
Drum diameter	175.5 mm (6 7/8")
Drum width.....	200 mm (7 7/8")
Drum speed.....	2400 rpm
Dimension of the sanding belt	200 x 750 (7 7/8" x 29 1/2")
Length.....	1040 mm (41")
Width	360 mm (14")
Height	1000 mm (39 3/8")
Weight of the machining housing.....	41 kg (90 lbs)
Weight of the motor	34 kg (75 lbs)
Weight of the guide tube	4 kg (9 lbs)
Overall weight	79 kg (174 lbs)
Dust emission at the workplace	< 2 mg/m ³ (0.024 gr./cu.yd.)
Workplace-related noise emission values	76 dB(A)

Intended applications

Sanding wooden and cork floors, plastic skating rings, with special version also machining of sheet metal surfaces.

Basic equipment

Machine ready for operation, dust bag, MultiClip for dust bag fixture, cable support, extension cable 3 x 2.5 sq. mm - 10 m long, O-ring as a strain relief device, operating instructions and safety remarks, tool kit complete with closed mouth wrench size 13/10, open-mouth wrench size 17, hexagonal socket wrench size 6 and 5, setting gauge, box wrench and respiratory protection mask P3.

Optional equipment

Carrying handle, TransCart, pocket for ear plugs, DI safety plug, safety belt.

Wearing parts

To ensure that the machine works safely and to maximum effect, please check the status of the wearing parts listed below at regular intervals:

- Replace extension cable if damaged
- Replace motor cable if damaged
- Replace sealing felt if worn or damaged
- Replace MultiClip if damaged
- Replace V-belt if worn
- Replace sanding drum if worn or damaged (after daily use, exchange every 1 - 2 years)
- Replace the tensioning roller if worn or damaged (after daily use, exchange every 1 - 2 years)
- Replace side cover if damaged
- Replace dust bag if worn or damaged
- Replace O-ring used as a strain relief if damaged
- Replace back wheel if worn or damaged
- Replace lateral wheels if worn or damaged

Never use the sanding machine for any type of wet operation!

When the machine is switched on, a serious residual risk still remains despite the presence of extensive safety devices. Never reach into rotating tools and machine parts!

The relevant article numbers of the optional accessories and wearing parts are provided in the spare parts lists in *Section 10*.

Commissioning

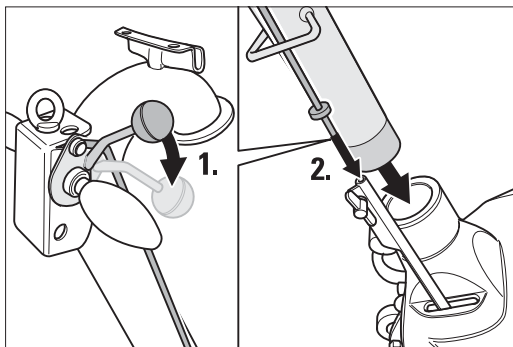

Fig. 2 When inserting the guide tube, make sure that the rod linkage of the lowering mechanism feeds in correctly!

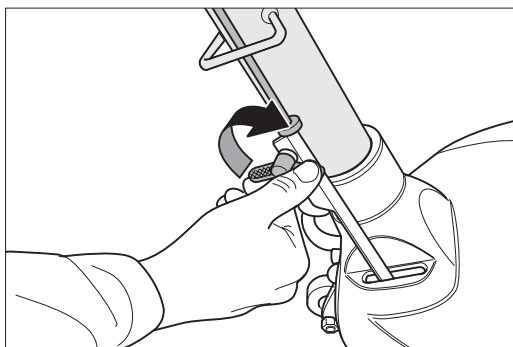

Fig. 3 After inserting the guide tube, carefully tighten the wing screw and ...

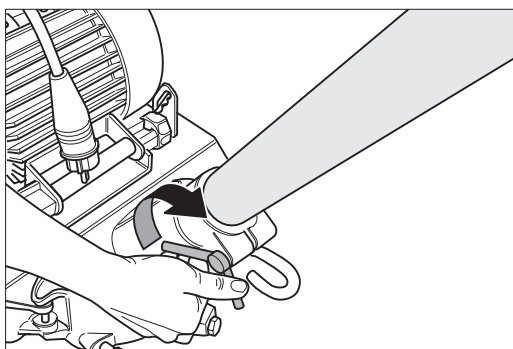

Fig. 4 ... the wing nuts.

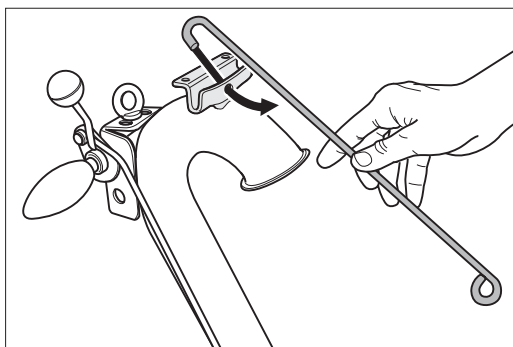

Fig. 5 Suspend the cable support into the provided hole.

This section describes the procedure for commissioning the HUMMEL on site. In order to exclude the possibility of damage and malfunctions, it is essential to proceed in the sequence outlined below.

Before working with the machine for the first time, operating staff must be adequately instructed!

3.1 PREPARING THE MACHINE FOR OPERATION

- 1 Unpack the machine carefully. The bottom part of the supplied transport crate makes a useful container for storage or transportation of the machine (see *Section 5, Transport and storage*). Please ensure that the packaging materials are responsibly disposed of.
- 2 Press the lowering lever downwards, insert the guide tube into the opening in the housing and at the same time place the top part of the lowering rod linkage into the bottom part of the rod linkage in the machine housing (Fig. 2).
- 3 Tighten the wing screw and the wing nut (Figs. 3 and 4).
- 4 Lift the sanding drum off the floor by turning the lowering lever upwards.
- 5 Mount the cable support onto the provided bracket at the top of the guide tube (Fig. 5)
- 6 Fasten the dust bag firmly using the cord and the MultiClip at the end of the guide tube, ensuring when mounting that the opening of the guide tube is not closed (Fig. 6).
- 7 Release the cover lock and remove the side cover on the right of the machine housing (Fig. 7).
- 8 To engage the sanding belt, pull the opposite lever upwards. This will lower the tensioning roller (Fig. 7).

PREPARING THE MACHINE

- 9 Position the sanding belt on the tensioning roller and push it over the sanding drum (Fig. 8).
- 10 Position the sanding belt so that it evenly covers the sanding drum (Fig. 9).
- 11 To tension the sanding belt, press the tensioning lever downwards (Fig. 10).

ATTENTION!

**Never switch on the motor before tensioning the sanding belt!
Never switch on the motor unless the sanding drum is raised off the floor!**

- 12 Connect the motor cable plug to the extension cable.
- 13 Plug in the extension cable to a adequately fused 230 V mains socket with PE contacts.
- 14 Before closing the housing opening by replacing the side cover, check the precise tracking of the sanding belt. **While doing so, the sanding drum must be raised off the floor!** Switch on the machine for around 2 seconds with the switch position -TEST- and check the sanding belt tracking.

Should the belt require readjustment, please check *Section 6.3, Checking sanding belt regulation.*

ATTENTION!

Never reach into the area of the belt while it is running. During the test run, ensure that no objects randomly positioned in the vicinity can be picked up by the sanding belt. This could result in serious injury or damage to the machine!

- 15 Close the housing opening with the side cover.

The machine is now ready for operation.

Before working with the machine for the first time, operating staff must be adequately instructed!

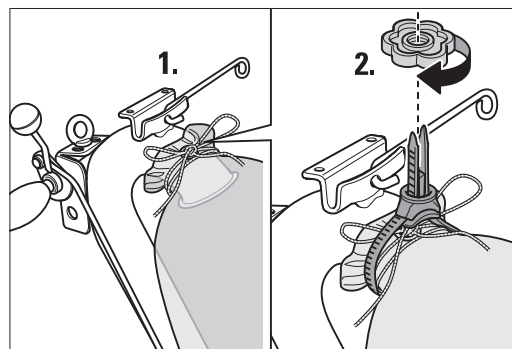

Fig. 6 Mount the dust bag without creasing using the cord and MultiClip.

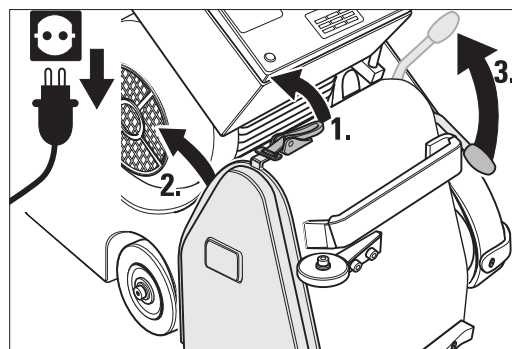

Fig. 7 Release the cover lock, remove the side cover and lower the tensioning roller by pulling up the lever.

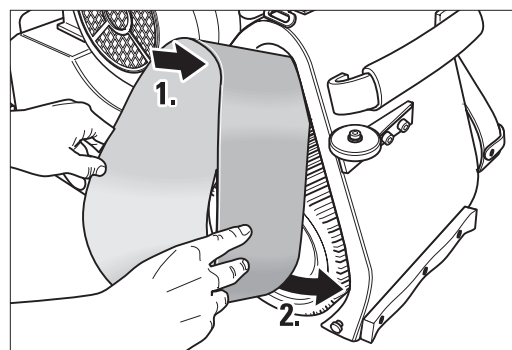

Fig. 8 Mount the sanding belt.

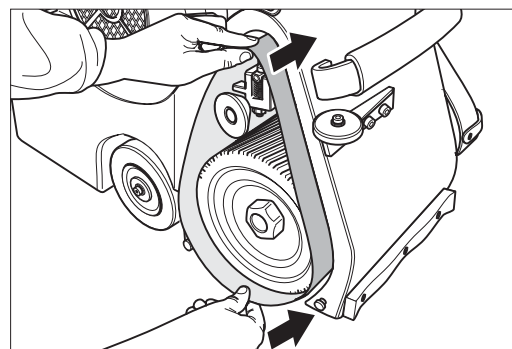

Fig. 9 Push the sanding belt far enough over the sanding drum and tensioning roller so that the sanding drum is fully covered by the belt.

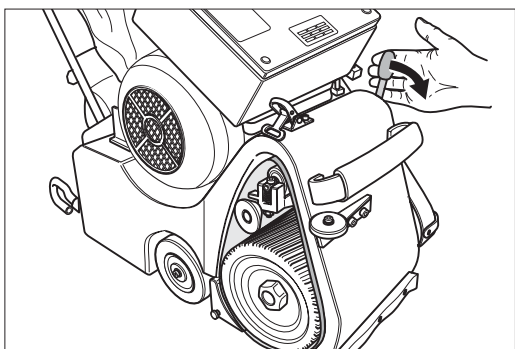

Fig. 10 Tension the sanding belt by lowering the tensioning lever.

3.2 STARTING THE MACHINE

ATTENTION!

**Never switch on the motor before tensioning the sanding belt!
Never switch on the motor unless the sanding drum is raised off the floor!**

Once the preparatory stages have been completed, the machine can be started. To start the motor, the switch must be held for around 2 seconds in the -START- position until the motor has reached full speed.

Remaining for too long in the -START- switch position shortens the service life of the starting capacitor! Once the motor has reached its full speed, release the switch button. The switch will then automatically move to the -WORKING- position.

Never allow the machine to run unattended, and always pull the mains plug out of the socket once you have finished working!

If the motor should ever be difficult to start in extremely cold conditions, the V-belt tension should be relaxed by loosening the eye bolt. Lower belt tension will allow the motor to start up more easily. Once the motor is up to temperature, remember to retension the belts using the eye bolt.

3.3 SWITCHING OFF THE MACHINE

To switch off, raise the sanding drum off the floor by actuating the lowering lever and turn the switch button to the -0- position. Wait until the sanding drum comes to a standstill before replacing the machine down onto the sanding drum. Never allow the machine to run unattended and always pull the mains plug out of the socket once you have finished working.

Working with the HUMMEL

4.1 APPLICATION TIPS

It is possible to avoid leaving deep sanding tracks caused by excessively coarse grit size by initially selecting a fine grit size for the first sanding process.

Carry out a test sanding process using a 50 or 60 grit size (a few test strokes). If this test is satisfactory and you envisage a good sanding result within a reasonable period, it is more efficient to start the sanding work off with these finer grit sizes.

You can avoid creating deep sanding tracks with the mentioned grit sizes by adhering to the grit size sequence and not skipping more than one grit size at a time.

After each sanding pass, vacuum the floor thoroughly, and clean the machine's wheels before starting each new sanding operation.

In order to avoid chatter marks, use sanding belts with bud joints and tape.

When changing to a new sanding belt, always start work in a less well lit area of the room until the sanding belt loses its initial aggressive sanding behaviour.

Always sand from left to right. This ensures that the left-hand lateral wheel always runs over the newly sanded surface, making the surface more even with each sanding pass and preventing waviness. One sanding pass comprises a forward and reverse movement over the same track without offset. Avoid a sanding track offset of more than 85%.

For other informative and important application tips, please refer to the LÄGLER application technology brochure „Sanding wooden floors“!

For more information free of charge, please apply to

within Germany:

- Tel.: 0800 / 52 34 537

- Fax: 0800 / 48 66 353

within the USA:

- Tel.: 800-848-6635

or

- Tel.: +49 - 7135 - 98 90-0

- Fax: +49 - 7135 - 98 90-98

- e-mail: info@laegler.com

- Internet: <http://www.laegler.com>

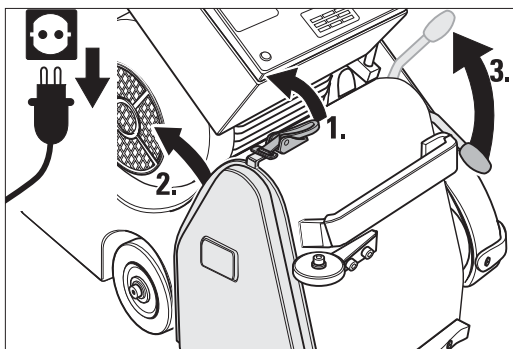

Fig. 11 Before exchanging, the sanding belt tension must be released. To do this, release the side cover and pull up the lever.

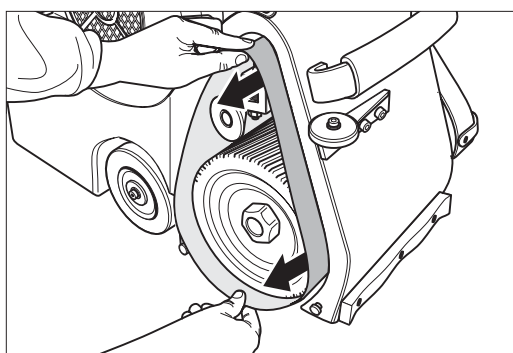

Fig. 12 Remove the worn sanding belt from the roller.

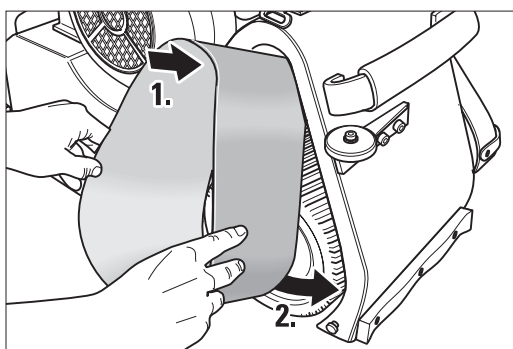

Fig. 13 Position the new sanding belt.

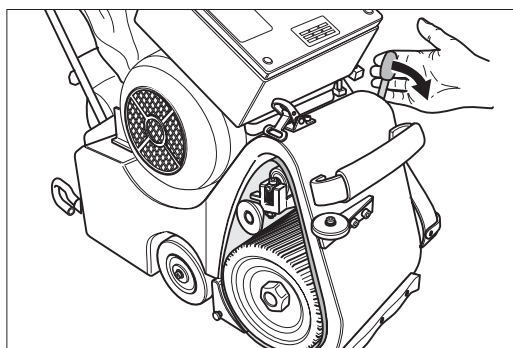

Fig. 14 Never forget to retension the sanding belt. Otherwise, damage or injury can occur!

4.2 CHANGING THE SANDING BELT

Depending on the type of sanding process you wish to perform, different abrasive grit sizes can be selected. In order to change the abrasive, proceed as follows:

- 1 Switch off the machine.
- 2 **Pull the mains plug out of the socket before performing any work at the machine!**
- 3 Remove the side cover (Fig. 11).
- 4 To release the tension on the sanding belt, pull up the opposite lever. This will lower the sanding drum (Fig. 11).
- 5 Exchange the sanding belt while the sanding drum is raised off the floor (Figs. 12 and 13).
- 6 To tension the sanding belt, press the tensioning lever downwards (Fig. 14).

ATTENTION!

Never switch on the motor before the sanding belt has been tensioned! Never switch on the motor unless the sanding drum is raised off the floor! Otherwise, injury or damage can occur!

- 7 Plug the mains plug into an adequately fused socket with PE contacts.
- 8 Before closing the housing opening, check the precise tracking of the sanding belt. To do this, switch on the machine for around 2 seconds in the -TEST- switch position and check the tracking of the sanding belt.

Should readjustment be required, please read *Section 6.3, Checking sanding belt regulation.*

- 9 Close the housing opening again using the side cover (Fig. 15).

It is now possible to execute the next sanding process with the machine.

4.3 REGULATING THE SANDING DRUM PRESSURE

The lever can be used to set three different drum pressure stages. These three stages - COARSE / MEDIUM / FINE - are designated on the notch plate as -GROB / MITT. / FEIN- (Fig. 16).

The pressure stage indications relate to the grit size sequence. The sanding pressure should be adjusted inline with the grit size sequence and reduced as the fineness of the grit size increases. This setting facility permits you to adjust the drum pressure to the prevailing circumstances.

For example when sanding with grit size 50 in the -GROB (COARSE)-setting, the same stock removal is achieved as when sanding with grit size 40 in the -MITT. (MEDIUM)- setting.

In order to avoid dish-outs when sanding soft wood floors, the sanding pressure should be reduced and the sanding speed increased.

4.4 EMPTYING THE DUST BAG

ATTENTION!

To avoid fire or explosive damage, always remove the dust bag from the machine following sanding and empty the contents into a non-combustible container! Seal this container with a non-combustible cover and always store both the container and the dust bag in the open!

The dust bag must be emptied when one third full at the latest. Otherwise, suction performance will deteriorate as the filter surface becomes clogged.

When emptying the dust bag, a respiratory protection mask P3 must be used.

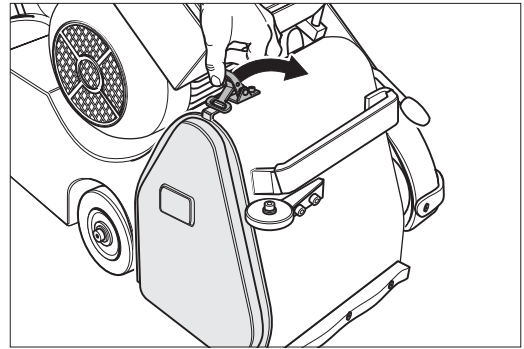

Fig. 15 After completed sanding belt changeover, replace the side cover.

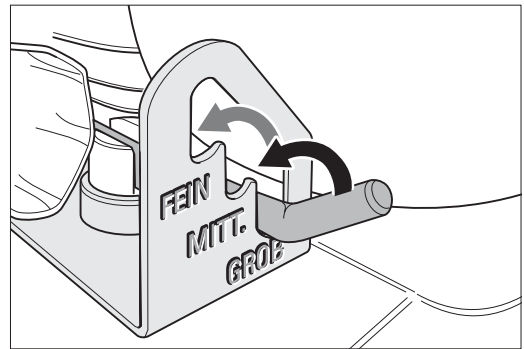

Fig. 16 Different sanding pressures stages can be selected using the setting lever.

Transport and storage

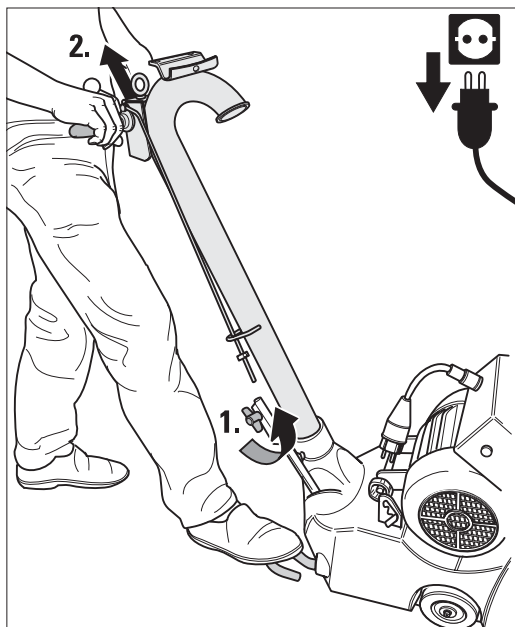

Fig. 17 After opening the wing screws and wing nuts which fasten the rod linkage, the guide tube can be drawn out of the machine housing.

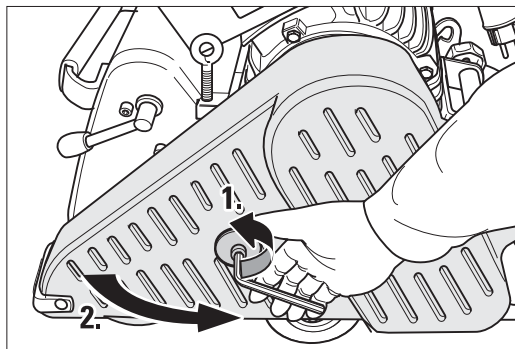

Fig. 18 Open the belt guard.

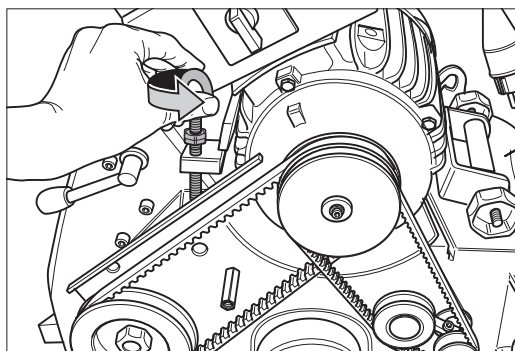

Fig. 19 Release the V-belt tension by loosening the eye bolt.

5.1 DISMANTLING THE MACHINE

For transportation, the machine can be dismantled into three parts: Guide tube, motor and machine housing. All parts must be adequately secured against slipping while being transported in the delivery van etc. During manual transport over roads and pavements, to protect the wheels and sanding drum, use the TransCart (for Art. no. see *Section 10, Spare parts*).

- 1 **Switch off the machine and pull the extension cable out of the socket!**
- 2 Open the wing screw and wing nut and pull the guide tube out of the machine housing (Fig. 17).
- 3 To remove the V-belt, open the belt guard (Fig. 18) and release the tension on the V-belt by releasing the eye bolt (Fig. 19).
- 4 Remove the suction belt by allowing it to run off the lower pulley by turning the motor pulley (Fig. 20). **Take care of your fingers → danger of crushing!**
- 5 Apply the box wrench (tool kit) to the lower pulley and turn the roller in the **clockwise direction** while allowing the drive belt to run off the pulley. Never turn anti-clockwise, as this could cause the screw joint to loosen (Fig. 21)! **Take care of your fingers → danger of crushing!**
- 6 Release the motor nuts. The motor nut must only be backed out from the fitting between the motor nut and motor bearing bracket, and not completely removed (Fig. 22 and 23).
- 7 Lift the motor out of the machine and secure it during transport against slipping and damage (Fig. 24).

Professional tip

During transportation, place a flat piece of wood between the floor surface and machine housing. This prevents the housing from slipping and stops the drum being in direct contact with the floor.

During transport, the machine can also be firmly lashed to the bottom part of the supplied transport crate using two belts (Fig. 25). This will prevent damage to the sanding drum and stop the wheels becoming out of round!

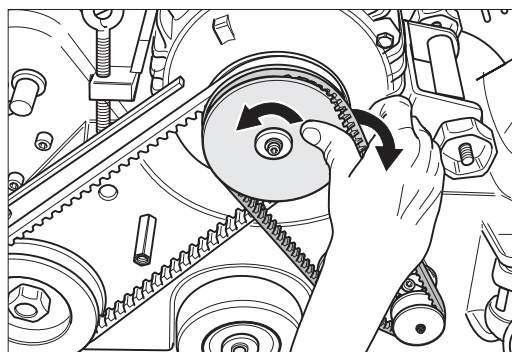

Fig. 20 Remove the suction V-belt.

5.2 ASSEMBLY AFTER TRANSPORTATION

When assembling the HUMMEL after transport, adhere to the following sequence of work steps:

- 1 Place the motor in the motor bearing bracket and tighten the motor nuts.
- 2 Mount the V-belts and tension using the eye bolt.
- 3 Close the belt guard.
- 4 Press the lowering lever downwards, now insert the guide tube in the housing opening and at the same time insert the lowering rod into the bottom part of the rod linkage in the machine housing (Fig. 2).
- 5 Tighten the wing screws and wing nuts (Figs. 3 and 4).
- 6 Plug the extension cable plug into an adequately fused 230 V mains socket with PE contacts.

The machine is now ready for use.

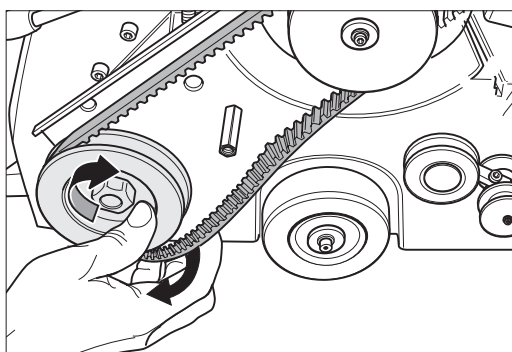

Fig. 21 Allow the drive belt to run off the lower pulley. If necessary, use the box wrench to help you, but turn exclusively in the **clockwise direction** in order not to release the screw joints.

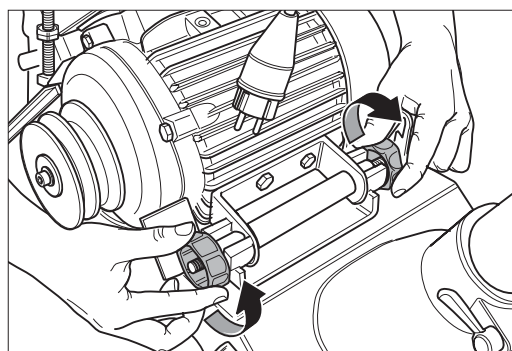

Fig. 22 Loosen the two motor nuts ...

5.3 STORAGE

If you wish to keep the machine in storage for a protracted period, ensure that it is kept dry and free of the influence of frost in a location without excessive temperature fluctuations.

Professional tip

When storing for long periods, place the machine on the bottom part of the supplied transport crate (Fig. 25) or place a support underneath the machine housing. This will prevent damage to the sanding drum and stop the wheels becoming out of round!

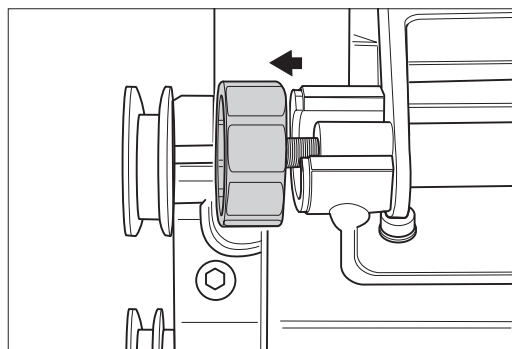

Fig. 23 ... until the two nuts used to fit into the motor bearing bracket are exposed.

Maintenance

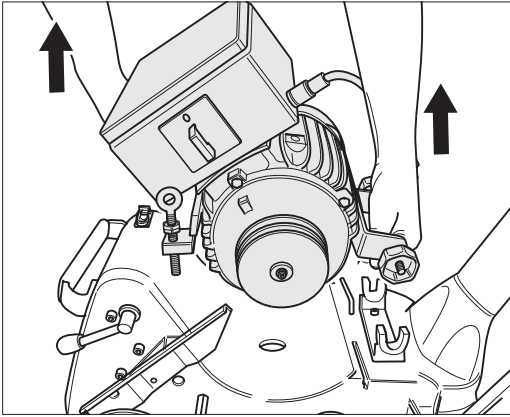

Fig. 24 Lift the motor out of the housing.

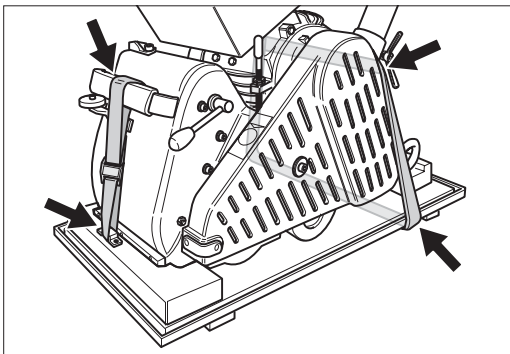

Fig. 25 Transport or store the machine on the bottom part of the transport crate.

ATTENTION!

Use exclusively original parts from LÄGLER! Only by doing so can the performance of your machine be guaranteed. Warranty claims arising due to the use of externally sourced parts will not be acknowledged!

Periodically but at the latest when you notice that damage has occurred, a variety of maintenance procedures have to be performed. For this work, use exclusively original spare parts from LÄGLER. Work in a clean, well lit location and proceed in accordance with these instructions. In the tool kit, you will find all the tools required to carry out the work described below.

It takes only a minimal amount of time to inspect the machine, but this precautionary measure can save subsequent complaints brought about by minor damage to the machine. Performing regular maintenance work will help to retain the value of the machine and is also in the interests of your own safety.

6.1 CLEANING AND CARE INSTRUCTIONS

Never use cleaning agents containing solvents!

Before starting work, you should perform the following care procedure in order to ensure that the machine is in full working order and produces the customary high-quality sanding finish:

- Check the tensioning roller and the sanding drum for damage. Clean the parts carefully and ensure that the rubber coating on the rollers is not damaged.
- Check belt tracking and set it if necessary using a grit size 120 sanding belt (*Section 6.3, Checking sanding belt regulation*).
- Clean the wheels of the machine.
- Check the belt tension / correct it with the aid of the eye bolt.
- Check that the lowering rod linkage is easy running.
- Carry out a visual inspection of the electrical equipment (extension cable, plug, couplings).

6.1.1 THE DRIVE UNIT

The drive unit should be removed and cleaned at least once a week if the machine is used every day. The drive unit is removed using the following procedure:

- 1 **Switch the machine off and pull the mains plug out of the socket!**
- 2 Ensure that the sanding drum is raised off the floor.
- 3 Release the cover lock and remove the side cover on the right of the machine housing (Fig. 26).
- 4 Pull the opposite operating lever for the drive unit upwards. This lowers the tensioning roller (Fig. 26).
- 5 Remove the abrasive belt (Fig. 27).
- 6 If you wish to remove the tensioning roller of the drive unit (*Section 6.6.2, Exchanging the tensioning roller*), press the operating lever for the drive unit downwards (Fig. 14).
- 7 Remove the operating lever by unscrewing (Fig. 28).
- 8 Release and remove the three hexagonal socket head screws (Fig. 29).
- 9 Carefully remove the unit and clean it (Fig. 30).

Reassemble in reverse order. After mounting the drive unit, check the belt tracking and set if required (*Section 6.3, Checking sanding belt regulation*).

Regular exchange of the sanding drum and tensioning roller guarantees a constant degree of operating quality and performance. When working every day with the machine, they must be exchanged every 1 - 2 years, otherwise every 3 – 4 years (see *Section 6.6.1 and 6.6.2*).

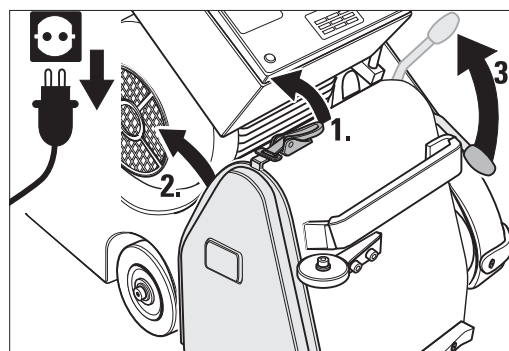

Fig. 26 Release the cover lock, remove the side cover and lower the tensioning roller by raising the lever.

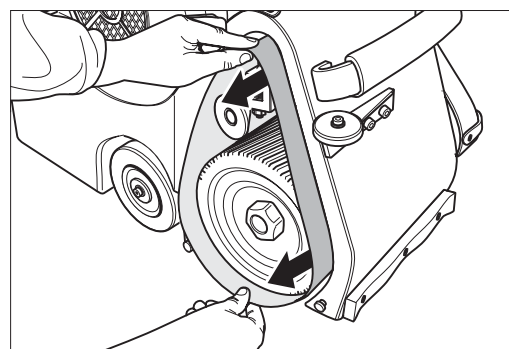

Fig. 27 Remove the sanding belt off the rollers.

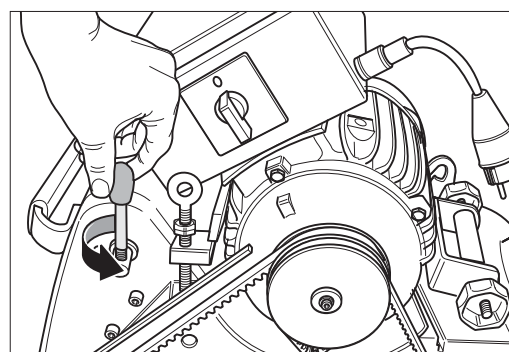

Fig. 28 Unscrew the lever.

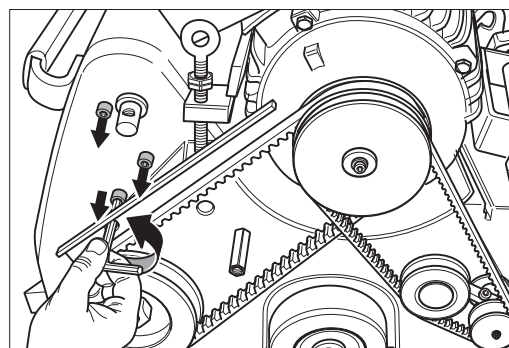

Fig. 29 Release and remove the three hexagonal socket head screws.

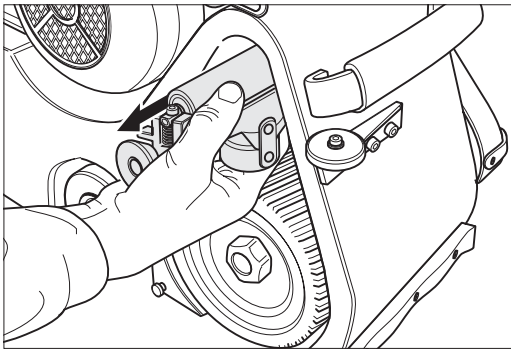

Fig. 30 Carefully remove the drive unit.

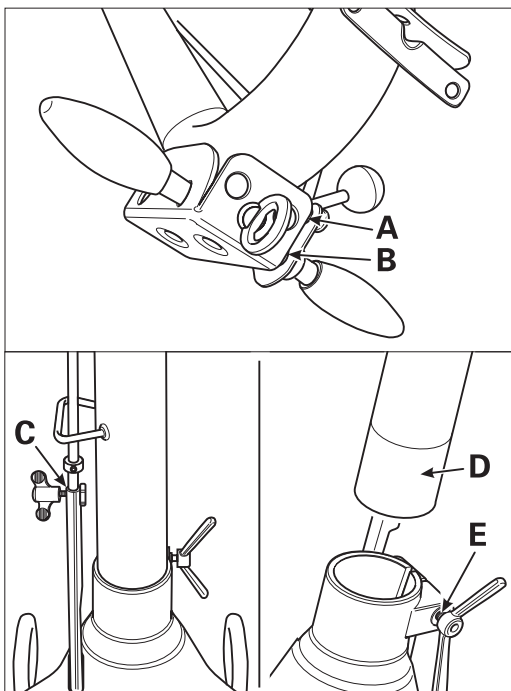

Fig. 31 Lubrication points which should be regularly oiled.

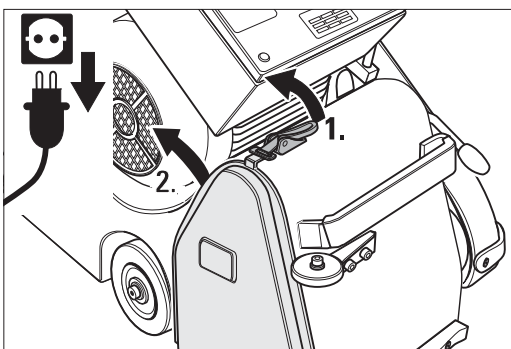

Fig. 32 Release the cover lock and remove the side cover.

6.2 LUBRICATION

For general upkeep of the machine, after around 100 operating hours we recommend sparing lubrication of the two lubrication nipples at the wheel bearings using a manual grease gun (tool kit) using ball bearing grease.

IMPORTANT

In newer models, this lubrication point has been replaced by a self-lubricating plastic bushing. This bushing does not require lubrication! Never use sprays such as WD 40 or similar!

In order to guarantee lasting easy running of the moving parts, lubricate at regular intervals at the following lubrication points (Fig. 31).

- A Top part of the rod linkage at the lever plate
- B Lever plate on the handle shaft

To do this, tilt the machine slightly to one side and allow a small amount of oil to run into the lubrication points.

- C Wing screw on the bottom part of the rod linkage
- D Guide tube in the machine housing
- E Wing nut at the housing

Use customary lubricating oil for these lubrication points - never use grease or sprays such as WD 40 or similar!

6.3 CHECKING SANDING BELT REGULATION

The sanding belt tracking must be checked every time the sanding belt is exchanged, but at least once a day.

Should readjustment be necessary, proceed as follows:

- 1 **Switch the machine off and pull the mains plug out of the socket!**
- 2 Remove the side cover (Fig. 32).
- 3 Check whether any soiling at the tensioning roller calls for readjustment. If so, the tensioning roller must be cleaned (*Section 6.1.1*) and the belt tracking must be checked again (*Section 4.2.8*).

CHECKING THE MACHINE SETTING

- 4 Always set the belt tracking using a sanding belt with as fine a grit size as possible (= flexible belt). This is because the more flexible the sanding belt, the precisely it is possible to set the tensioning roller.

Mount the sanding belt and carry out a test run (Section 4.2.8).

If the belt is running out of true, it must be turned around and another test performed.

If the belt runs in the same direction both times, the tensioning roller requires readjustment. If the belt runs to the front and after turning over runs to the back or vice versa, the belt is of poor quality and should be returned to the manufacturer with a complaint (conical sleeve).

- 5 However, if readjustment is necessary, release the lock nut at the drive unit and adjust the hexagonal socket head screw (Fig. 33).

A Rotation to the right = belt runs to the front

B Rotation to the left = belt runs to the back

- 6 If the belt tracking is seen to be correct after adjusting once, tighten the lock again. If not, repeat the process.
- 7 Replace the side cover.

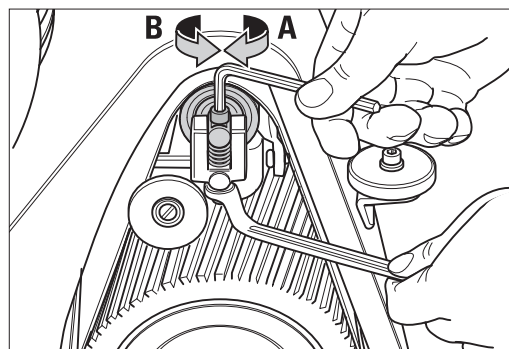

Fig. 33 Adjust the belt tracking at the setting screw of the drive unit (see description on the left).

6.4 CHECKING THE MACHINE SETTING

From time to time, or as a result of incorrect transportation, it is possible for the machine to become incorrectly adjusted. Incorrect adjustment is indicated by one-sided sanding of the sanding drum, which can lead to sanding tracks and complaints. Correction of machine settings is performed as follows:

- 1 **Switch off the machine and pull the mains plug out of the socket!**
- 2 Tilt the machine backwards over the safety guards so that you can see the wheel bearings (Fig. 34). **Ensure that the machine is standing securely!**
- 3 The wheel on the belt guard side can be adjusted by releasing the tension screw. The other wheel is firmly fixed using a screw.

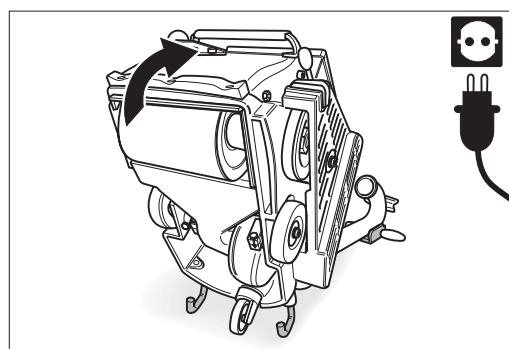

Fig. 34 To check the machine setting, tilt the machine backwards. **Ensure that the machine is standing securely!**

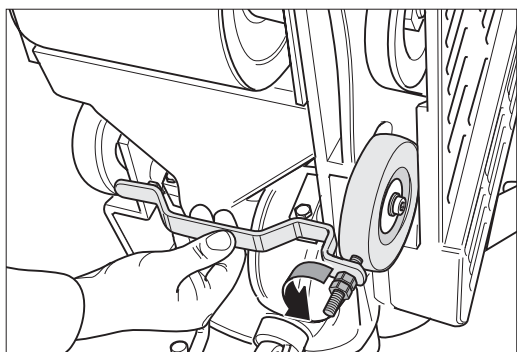

Fig. 35 Remove the current setting fixture from the right-hand wheel (seen from below).

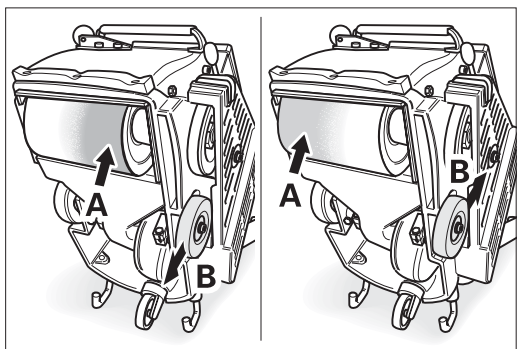

Fig. 36 If the drum is no longer sanding on side A, the wheel must be adjusted in the direction of B.

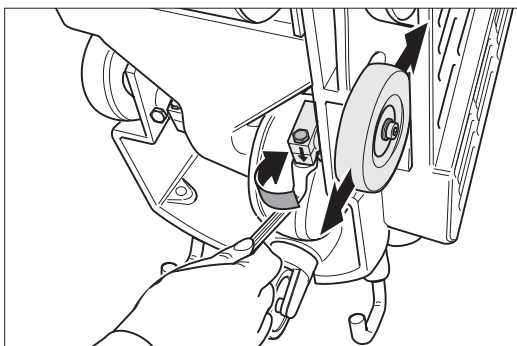

Fig. 37 Release the screw on the right-hand wheel clamp.

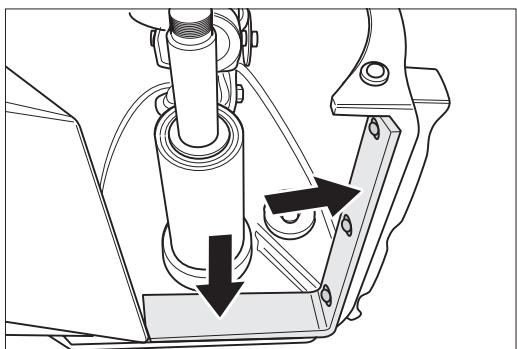

Fig. 38 The sealing felt must not demonstrate any signs of damage, otherwise replace.

4 For setting, first take the actual position of the adjustable wheel using the setting fixture. Position the fixture against the machine housing in such a way that it rests not only against the machine housing on both sides, but also at the adjustable wheel. If necessary, turn the threaded pin of the setting device. To do this, release the two nuts of the setting fixture (Fig. 35).

5 If the machine is sanding more heavily on the belt guard side, the **wheel must be adjusted away from the housing** (Fig. 36).

If the machine is sanding more heavily on the side cover side, the **wheel must be adjusted towards the housing** (Fig. 36).

Now adjust the threaded pin of the setting device in the relevant direction by the required amount.

6 Release the clamping screw at the wheel clamp of the adjustable wheel and place the setting fixture against the machine housing again (Fig. 37).

7 Set the wheel in the required position by means of the setting device so that the wheel lining just still makes contact with the threaded pin when turning, and tighten the clamping screw again.

8 Carry out a sanding test to check whether the machine is now correctly adjusted. If not, the process will have to be repeated.

The best working result is achieved when the machine sands centrally; only with this setting is it possible to avoid the belt from sanding too deep on one side, resulting in unwanted sanding tracks.

6.5 CHECKING THE DUST PICK-UP

In order to guarantee optimum dust pick-up for your safety and that of others, the following points must be observed:

- Always used original LÄGLER dust bags.
- Never use damaged dust bags.
- Ensure that the sealing felt is not worn or damaged (Fig. 38).
- Check the suction system for blockages or deposits.

6.6 REPLACEMENT OF WEARING PARTS

Replacing wearing parts in good time makes an important contribution towards maintaining the value of your machine and will prevent complaints caused as a result of worn parts.

The sections below explain the correct professional way to replace worn parts.

6.6.1 EXCHANGING THE SANDING DRUM

Use exclusively original LÄGLER sanding drums (Art. no. in *Section 10*).

- 1 **Switch off the machine and pull the plug out of the socket!**
- 2 Remove the side cover (Fig. 32)
- 3 Tilt the machine backwards over the safety guards so that you can see the wheel bearings (Fig. 34). **Ensure that the machine is standing securely!**
- 4 Open the drum nut using the box wrench. Note that the drum nut has a left-hand thread (Fig. 39). If necessary, take a soft hammer to help you loosen the nut. **Never use a steel hammer!**

Caution: left-hand thread!

- 5 Turn the drum in such a way that the fitting key is pointing upwards to ensure that the fitting key is not lost (Fig. 40). Now pull the roller out sideways out of the housing.

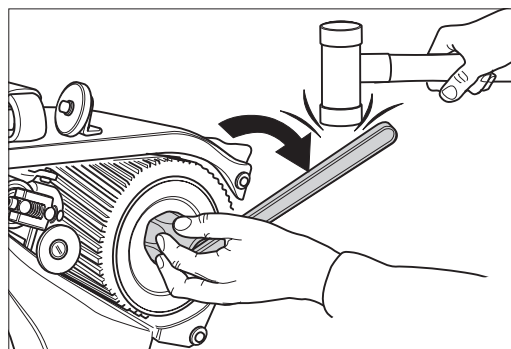

Fig. 39 Release the box nut (**left-hand thread**), if necessary by knocking gently with a soft hammer. **Never use a steel hammer!**

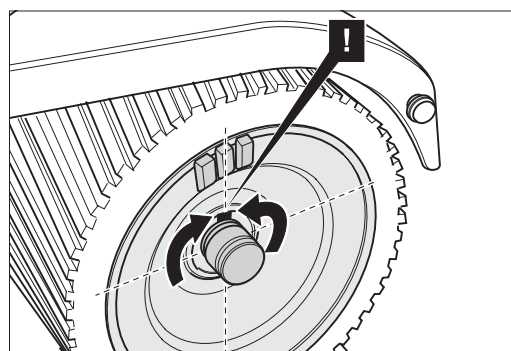

Fig. 40 Turn the drum in such a way that the groove is pointing upwards, to ensure that the fitting key is not lost.

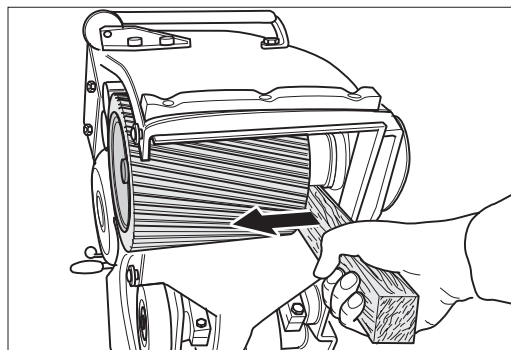

Fig. 41 If the drum is too stiff to be removed, carefully lever it away with a wooden lathe. **Never use brute force!**

EXCHANGING THE TENSIONING ROLLER

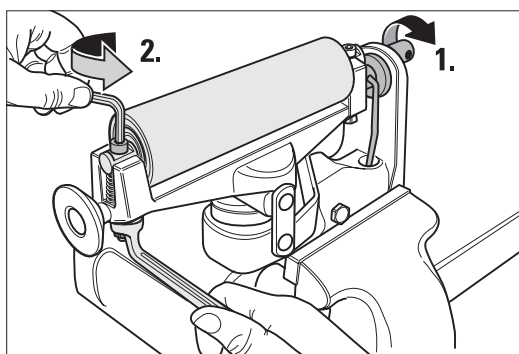

Fig. 42 Back out the hexagonal socket head screws while holding on to the lock nuts with the closed mouth wrench. If necessary, turn the crank in the indicated direction.

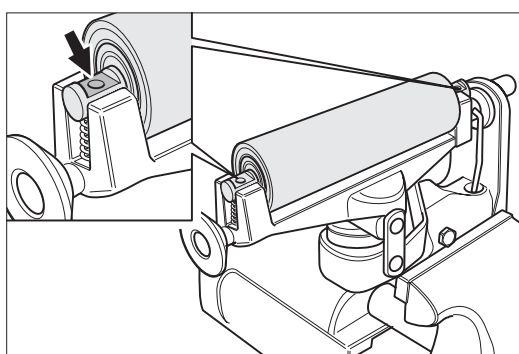

Fig. 43 Insert the new tensioning roller, ensuring that the surfaces on the shaft ends are pointing upwards.

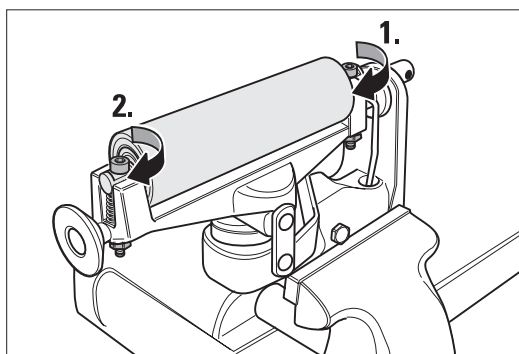

Fig. 44 Tighten the side without spring (1) and then the side with spring (2), so that ...

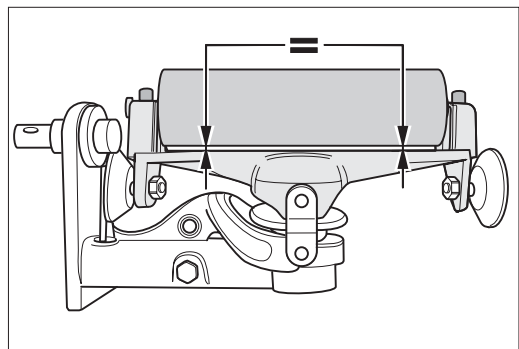

Fig. 45 ... the tensioning roller is positioned parallel to the top of the drive unit.

If the sanding drum is too stiff to move, use a wooden lever (see Fig. 41) to dislodge it, so as not to damage the machine. Never attempt to loosen the sanding drum by hitting with a hammer!

- 6 Clean the shaft stump and oil it slightly.
- 7 Push on the new roller, paying attention to the fitting keys.
- 8 Perform the remaining assembly steps in reverse order.

6.6.2 EXCHANGING THE TENSIONING ROLLER

Use exclusively original LÄGLER tensioning rollers (Art. no. in *Section 10*). However first remove the drive unit as described in *Section 6.1.1*. Then proceed as follows:

- 1 Clamp the drive unit in a vise and release the two fixing screws in the tensioning roller, holding onto the locknuts with a closed-mouth wrench. If you are unable to reach the lock nuts with the closed-mouth wrench, screw the lever into the crank again and turn it downwards so that the top of the drive unit is lifted up (Fig. 42).
- 2 Remove the tensioning roller and check the compression spring. Should this be deformed, the compression spring (Art. no. in *Section 10*) must be renewed.
- 3 Clean the drive unit.
- 4 Insert the compression spring in the tensioning roller. Ensure that the surfaces on the shaft ends of the roller are pointing upwards (Fig. 43)! Tighten the screw of the unsprung bearing pedestal side (Fig. 44).
- 5 Turn the screw on the sprung side of the tensioning roller far enough so that the tensioning roller is positioned parallel to the upper part of the drive unit (Figs. 44 and 45).
- 6 Tighten the lock nuts of the fixing screws.
- 7 Remount the drive unit as described in *Section 6.1.1*.
- 8 Check belt tracking as described in *Section 6.3*.

EXCHANGING THE BACK WHEEL

6.6.3 EXCHANGING THE BACK WHEEL
(WHEEL ONLY OR WHEEL ASSEMBLY)

Use exclusively original LÄGLER back wheels (Art. no. in *Section 10*).

- 1 **Switch off the machine and pull the plug out of the socket!**
- 2 Tilt the machine forward over the bracket. **Ensure that the machine is standing securely!**

Rear wheel only:

- 3 Release the screw in the centre of the wheel and remove the screw, washers and nut (Fig. 46). Ensure that you do not lose the nut.
- 4 Pull the back wheel off the tail axle housing.
- 5 Push the new back wheel onto the tail axle housing.
- 6 Insert the nut in the hexagonal recess of the tail housing and hold onto the nut. Mount the washers and the screw.

Complete rear wheel assembly:

- 7 If you wish to exchange the complete back wheel with tail housing, release the screw which fastens the tail axle of the rear wheel in the machine housing (Fig. 47).
- 8 Pull the tail axle with the tail housing out of the borehole in the housing (Fig. 47).
- 9 Mount the complete new back wheel in reverse sequence and fasten it again in the machine housing, aligning the clamping surface of the tail axle towards the screw (Fig. 47).

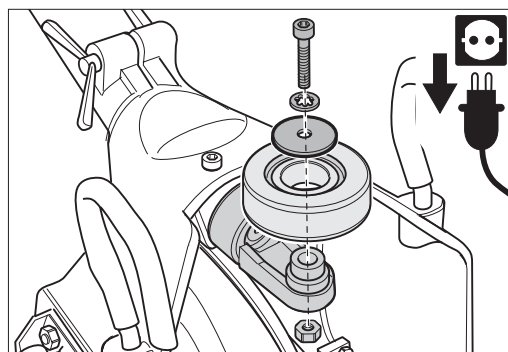

Fig. 46 Tilt the machine forwards over the bracket. Remove the screw with the washers and nut in the centre of the wheel and take off the back wheel. Assemble in reverse sequence. **Ensure that the machine is standing securely!**

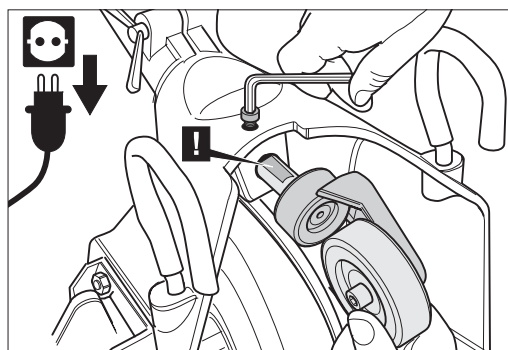

Fig. 47 Tilt the machine forwards over the bracket and release the holding screw. When mounting, align the tensioning surface of the tail axle towards the screw. **Ensure that the machine is standing securely!**

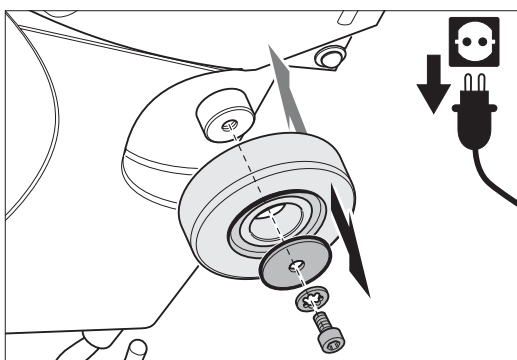

Fig. 48 Remove the screw with the washers in the centre of the wheel and remove the lateral wheel. Replace in reverse sequence.

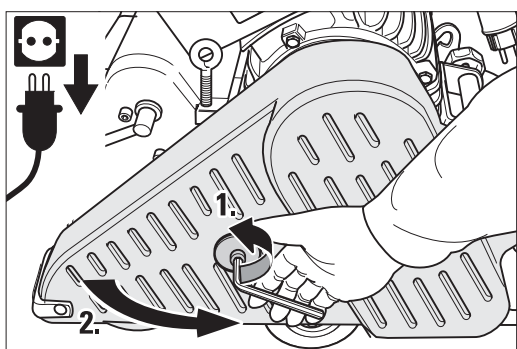

Fig. 49 Pull out the mains plug and open the belt guard.

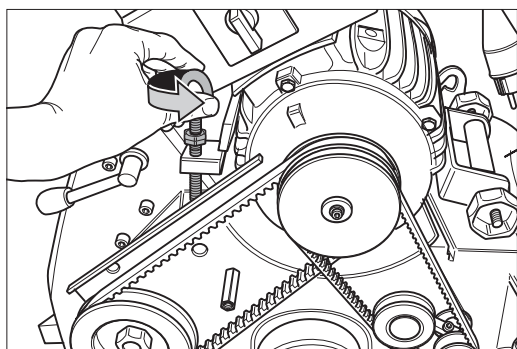

Fig. 50 Release the V-belt tension by loosening the eye bolt.

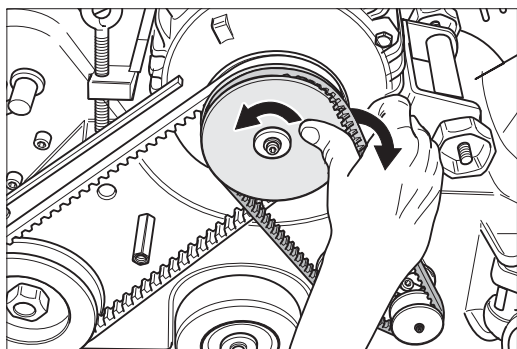

Fig. 51 Remove the suction V-belt.

6.6.4 EXCHANGING THE LATERAL WHEELS

Use exclusively original LÄGLER lateral wheels (Art. no. in *Section 10*).

- 1 **Switch off the machine and pull the plug out of the socket!**
- 2 Tilt the machine back over the safety guard (Fig. 34). **Ensure that the machine is standing securely!**
- 3 Release the screw in the centre of the wheel and remove the screw and washers (Fig. 48).
- 4 Pull the wheel off the wheel lever.
- 5 Push the new wheel onto the wheel lever.
- 6 Mount the washers and the screw.
- 7 Tighten the screw again.

The lateral wheels must always be exchanged in pairs.

Professional tip

As it is so easy and quick to exchange the lateral wheels and the back wheel, it is advisable to use a second set of wheels when performing rough work.

6.6.5 EXCHANGING THE V-BELT

Use exclusively original LÄGLER V-belts (Art. no. in *Section 10*).

- 1 **Switch off the machine and pull the plug out of the socket!**
- 2 To remove the V-belt, open the belt guard (Fig. 49) and release the V-belt tension by loosening the eye bolt (Fig. 50).
- 3 Open the clamping screw of the belt tensioner for the fan V-belt, and release the tension of the V-belt before removing it (Fig. 51).
- 4 Apply the box wrench to the sanding shaft and turn it **clockwise** while allowing the belt to run off the pulley (Fig. 52). **Pay attention to avoid squashing your fingers!**

ATTENTION!

Only turn through in the clockwise direction, as otherwise the screw joint will work loose.

- 5 Mount the new V-belt and tension the drive belt using the eye bolt. The slack on the belt should be just under one belt width (Fig. 53).
- 6 By turning the tensioner, tighten the smaller suction belt and carefully tighten the clamping screw (Fig. 54).
- 7 Close the belt guard.

ATTENTION!

Do not tighten the V-belt excessively, as this can cause damage to the belt and bearings. Check the V-belt tension after a certain run-in period.

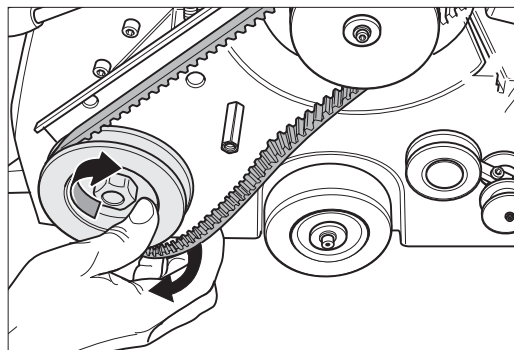

Fig. 52 Allow the drive belt to run off the lower pulley. If necessary use a box wrench to help you, but turn exclusively in the **clockwise direction** in order not to loosen the screw joint.

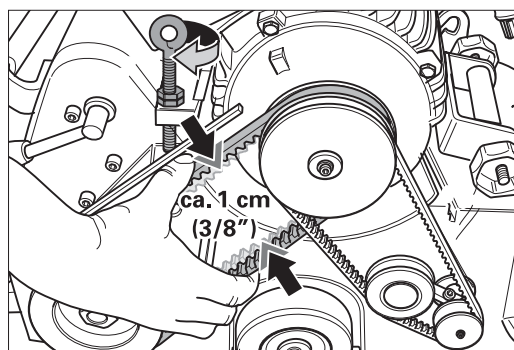

Fig. 53 Belt tension: The slack on the belt should be just under one width of the belt.

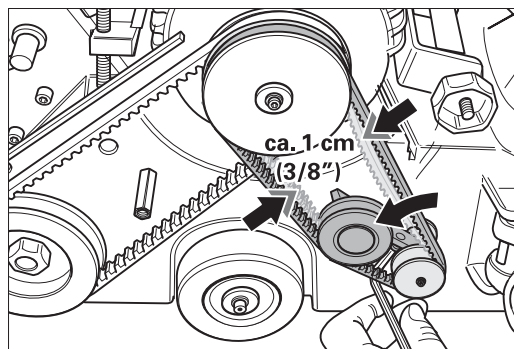

Fig. 54 Tension the suction V-belt using the belt tensioner.

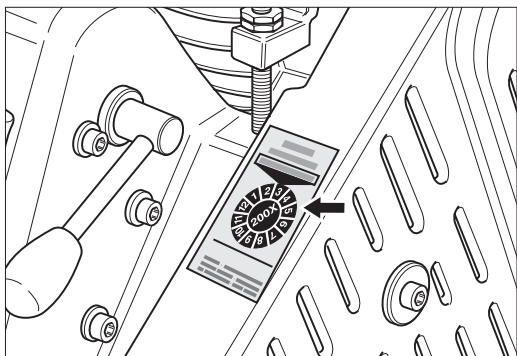

Fig. 55 The test seal is a safety certification.

6.7 REGULAR MAINTENANCE AND TESTING IN ACCORDANCE WITH ACCIDENT PREVENTION REGULATIONS

The electrical operating equipment and machine components must be checked for their electrical and mechanical safety at least once a year by a specialized staff member, repaired if necessary and then their safety certified by application of a test seal on the machine.

The elements required for dust pick-up must be checked at least once a year by a specialist and also repaired if necessary. They must also be certified as being in good working order.

Ensure that exclusively original LÄGLER spare parts are used for maintenance work. After-sales servicing should be performed by LÄGLER or by a LÄGLER-approved workshop.

The servicing passport on the cover page of these operating instructions documents when and where you have had your machine serviced.

Ensure that maintenance work is recorded in the servicing passport (*Section 11*) by completing the relevant box with date, stamp and signature.

Troubleshooting

MACHINE FAILS TO START UP

The machine fails to start up

- Check the power supply, connect if applicable. Check the fuses.
- Have the electrical equipment tested by a qualified electrician (capacitors, contactor, cable and switches)
- The thermal switch has tripped. Allow the machine to cool down.

The machine attempts to start up but is inhibited

- At low temperatures: Allow the machine to warm up to room temperature in a warm room.
- Insufficient voltage: Check the conductor quality and length. Insufficiently dimensioned cable cross-sections (strand dia. smaller than 2.5 sq.mm) and excessively long supply lines should be avoided, if necessary use a transformer (e.g. Art. no. 708.00.00 for 230 Volts).
- Check the tension of the V-belts and correct if necessary.

POOR MACHINE RUNNING CHARACTERISTICS

The machine is running but with no or insufficient sanding output

- At low temperatures: Allow the machine to warm up to room temperature in a warm room.
- Insufficient voltage: Check the conductor quality and length. Insufficiently dimensioned cable cross-sections (strand dia. smaller than 2.5 sq.mm) and excessively long supply lines should be avoided, if necessary use a transformer (e.g. Art. no. 708.00.00 for 230 Volts).
- Check the tension of the V-belts and correct if necessary.
- Check that the drive elements are not blocking or sticking.
- Incorrect or blunt abrasive.

The machining is creating excessive noise and vibrations

- Check the sanding drum and tensioning roller for dirt deposits.
- Check the belt tracking and adjust if necessary.
- Check the sanding belt for damage.
- Check the belt drive.
- Check the machine for blockages and deposits.

This section indicates how possible errors can be remedied. Should the actions outlined here fail to bring about a solution to the problem, please do not hesitate to contact Customer Services Department, which will be pleased to advise you. Our fully trained and qualified service technicians are highly familiar with the HUMMEL and will be able to provide any assistance you may need.

The circuit diagram applicable for your machine is located in the motor switch box.

 GENERAL SAFETY REMARKS

The machine is running well but creating dust

- The dust bag is over-full.
- The dust bag is not correctly mounted or damaged.
- The sealing felt is damaged.
- Check the suction system for blockages and clean if necessary.
- The V-belt of the suction system is damaged or not sufficiently tensioned.
- The side cover is not mounted at the machine.

SANDING ERRORS

Waviness, streaks, scratches

- The sanding drum or tensioning roller is damaged.
- Incorrect abrasive used.
- The wheels are soiled or damaged.
- Driving elements or V-belt damaged.
- The lowering rod linkage is running poorly, catching on something or getting stuck.
- The machine setting is incorrect.
- The operator is exerting the wrong sanding pressure.
- Incorrect work method or work not correctly performed.

General safety remarks

ATTENTION!

When working with power tools and machines, the following fundamental safety measures must be observed at all times in order to protect against electric shocks and danger of fire and injury. Read and observe these instructions before using the machine. Take good care of these safety instructions and keep them to hand at all times!

Never leave the filled dust bag unattended

To avoid fire or explosive damage, always remove the dust bag from the machine following sanding and empty the contents into a non-combustible container! Seal this container with a non-combustible cover and always store both the container and the dust bag in the open!

Keep the work area tidy

Untidiness in the work area results in a risk of accidents.

Be aware of environmental influences

Never leave the machine out in the rain. Do not use the machine in humid or wet atmospheres. Ensure that good lighting is provided. Never use the machine close to fire sources, combustible fluids or gases.

Keep away from sources of fire. Do not smoke when in a dust-laden atmosphere (e.g. during work or when emptying the dust bag) → danger of dust explosion.

Guard against electric shocks

Avoid bodily contact with earthed components such as pipes, radiators, stoves, fridges. Use the DI safety plug (Art. no. in *Section 10*).

Keep children and unauthorized persons at a distance

Do not allow children or any unauthorized persons to touch the machine or the cable, keep them away from the work area.

Ensure secure storage of the machine

Unused machines should be kept in dry, locked locations out of the reach of children.

Do not overload the machine

You will be able to work better and more safely within the specified performance range.

Use the right machine

Do not subject underpowered machines or attachments to excessive work loads. Refrain from using machines for purposes and work for which they are not intended.

Wear suitable work clothing

Do not wear loose clothing or jewellery which could be caught in moving parts of the equipment.

Use safety gear

Use respiratory masks with filter class P3 when working in dust-laden atmospheres.

Only use the cable for its intended purpose

Never use the cable to carry or pull the machine, or to pull the plug out of the socket. Protect the cable from the effects of heat, oil, and sharp edges.

Never bend too far over the machine

Avoid any abnormal posture. Make sure you are standing firmly and securely, keeping your balance at all times.

Take good care of your machine

Keeping your machine in a clean, tidy condition will allow you to work more efficiently and safely. Comply with the maintenance regulations and the tool changing instructions. Check the cables

ATTENTION!

For your own safety, only use accessories and attachments which are indicated in the operating instructions or offered in the relevant catalogue. The use of other tools or accessories than those recommended in the operating instructions can result in danger of personal injury.

Take care of these instructions and keep them within easy reach.

Observe the valid regulations of your employers' liability insurance association.

regularly and have them exchanged by an expert if damaged. Check the extension cable regularly and replace if damaged. Keep all handles dry and free of oil and grease.

Pull the plug out of the socket

When not using the machine, during performing maintenance work and when changing tools, the mains plug must be pulled out of the socket.

Never leave setting tools or attachments in the machine

Before switching on, always check that you have removed all setting tools and attachments.

Avoid unintentional start-up

Ensure that the ON/OFF switch is not activated when connecting the machine to the mains.

Be alert to potential dangers

Always keep a close watch on what you are doing. Act sensibly, never use the machine when you are having difficulty concentrating.

Check your machine for damage

Before making further use of the machine, check the safety devices or damaged parts with care and test that all machine functions are in correct working order. Check whether moving parts are working correctly, whether they are jamming, whether any parts are broken, whether all other parts are correctly mounted and all other conditions which could influence operation of the machine are correct.

Unless otherwise specified in the operating instructions, damaged safety devices and parts must be repaired or exchanged professionally by an after-sales workshop. Damaged switches must be replaced by an after-sales workshop. Never use machines with switches which cannot be turned on or off.

CIRCUIT DIAGRAM

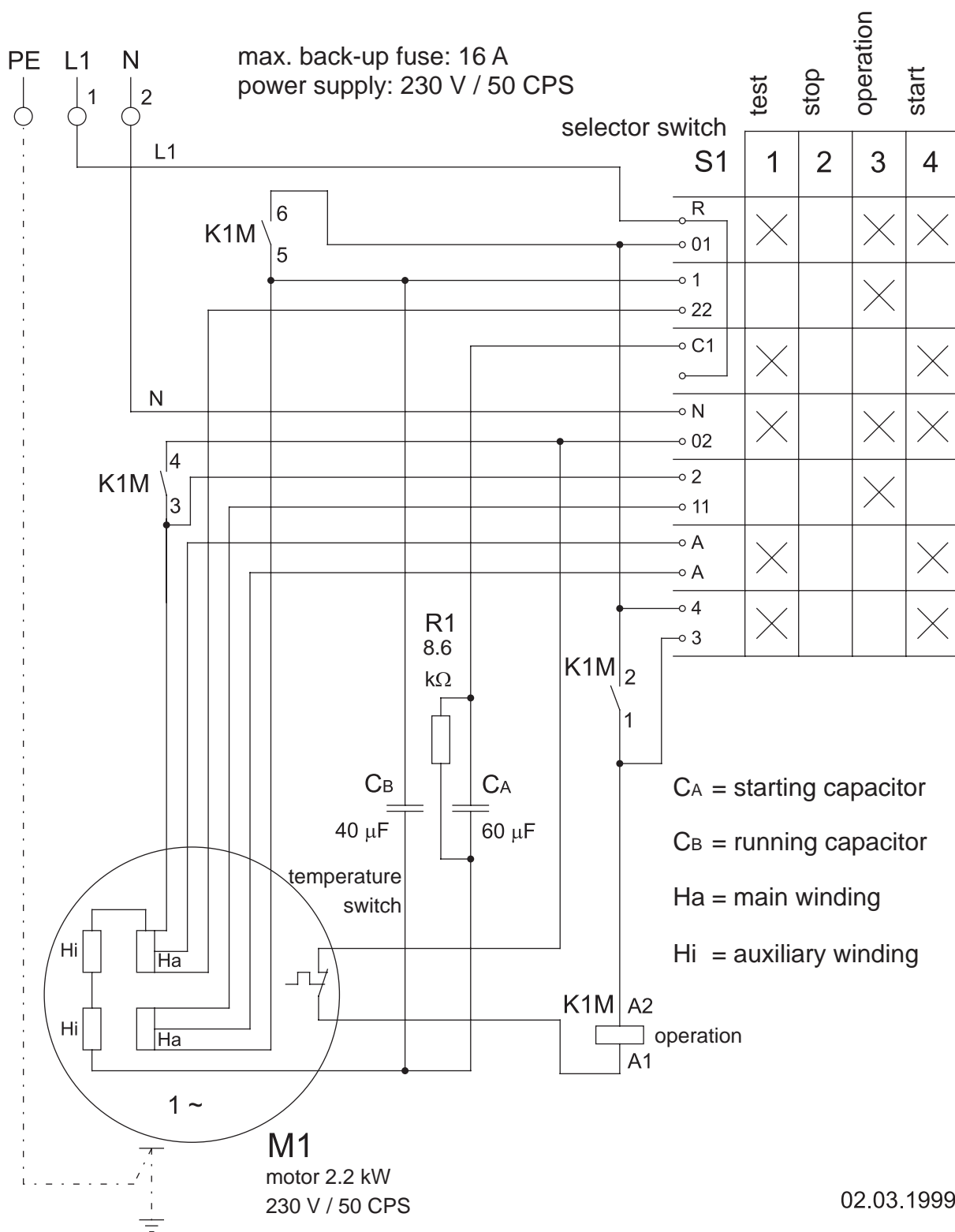

HUMMEL + ELF: single-phase AC motor

2.2 kW / 230 V / 50 CPS

EUGEN LÄGLER GMBH
Industriegebiet Kappelrain
D-74363 Güglingen-Frauenzimmern

Telefon: +49 - 7135 - 98 90 - 0
Fax: +49 - 7135 - 98 90 - 98

E-Mail: info@laegler.com
Internet: http://www.laegler.com

The circuit diagram valid for your machine is located in the motor switch box.

CIRCUIT DIAGRAM

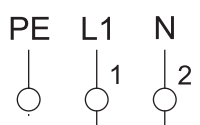

max. back-up fuse: 20 A
power supply: 220 + 230 V / 60 CPS

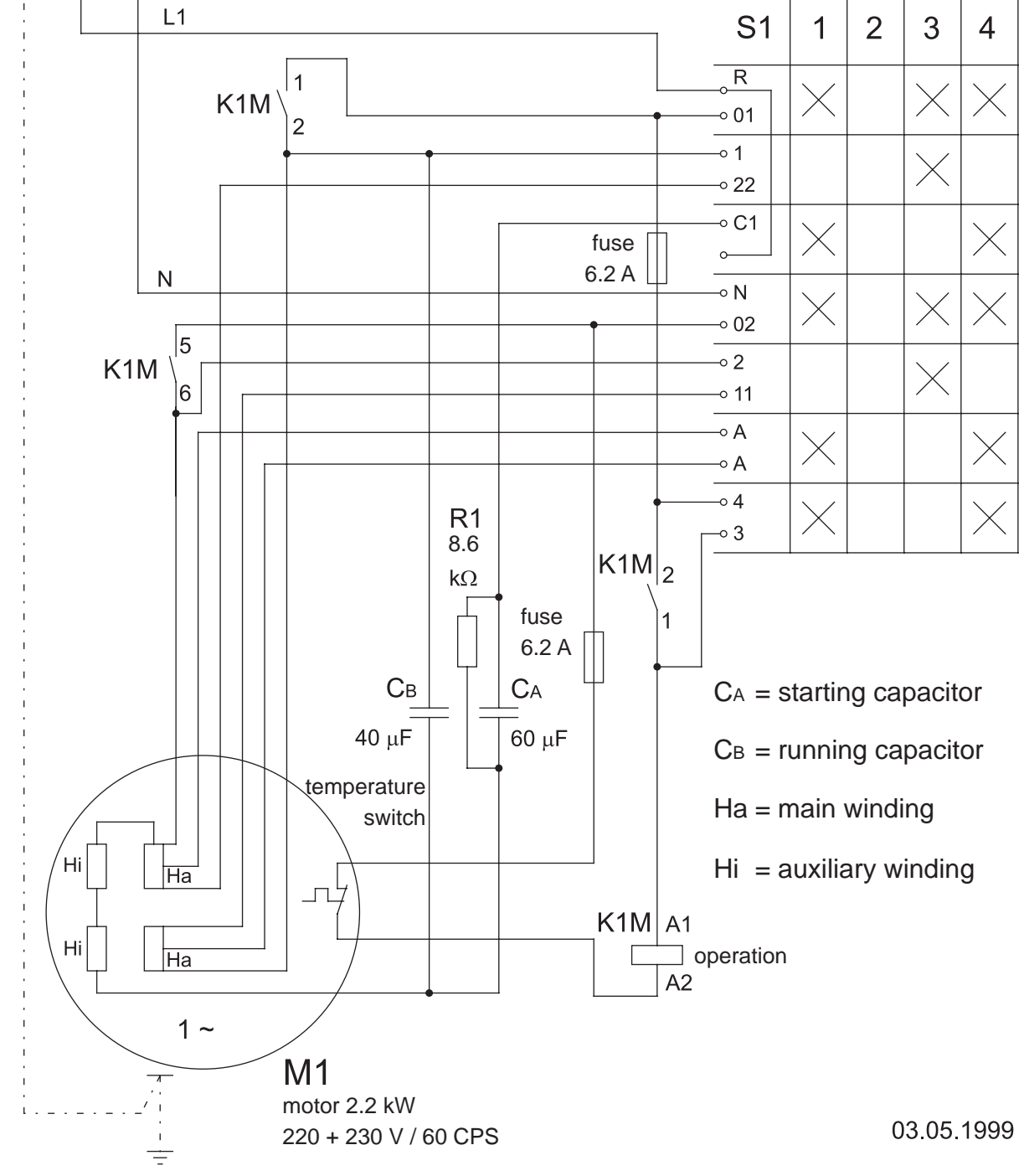

	test	stop	operation	start
S1 1	×		×	×
S1 2			×	
S1 3	×			×
S1 4	×			×

- CA = starting capacitor
- CB = running capacitor
- Ha = main winding
- Hi = auxiliary winding

M1
motor 2.2 kW
220 + 230 V / 60 CPS

03.05.1999

HUMMEL + ELF: single-phase AC motor		2.2 kW / 220 V / 60 CPS 2.2 kW / 230 V / 60 CPS
EUGEN LÄGLER GMBH Industriegebiet Kappelrain D-74363 Güglingen-Frauenzimmern	Telefon: +49 - 7135 - 98 90 - 0 Fax: +49 - 7135 - 98 90 - 98	E-Mail: info@laegler.com Internet: http://www.laegler.com

The circuit diagram valid for your machine is located in the motor switch box.

CIRCUIT DIAGRAM

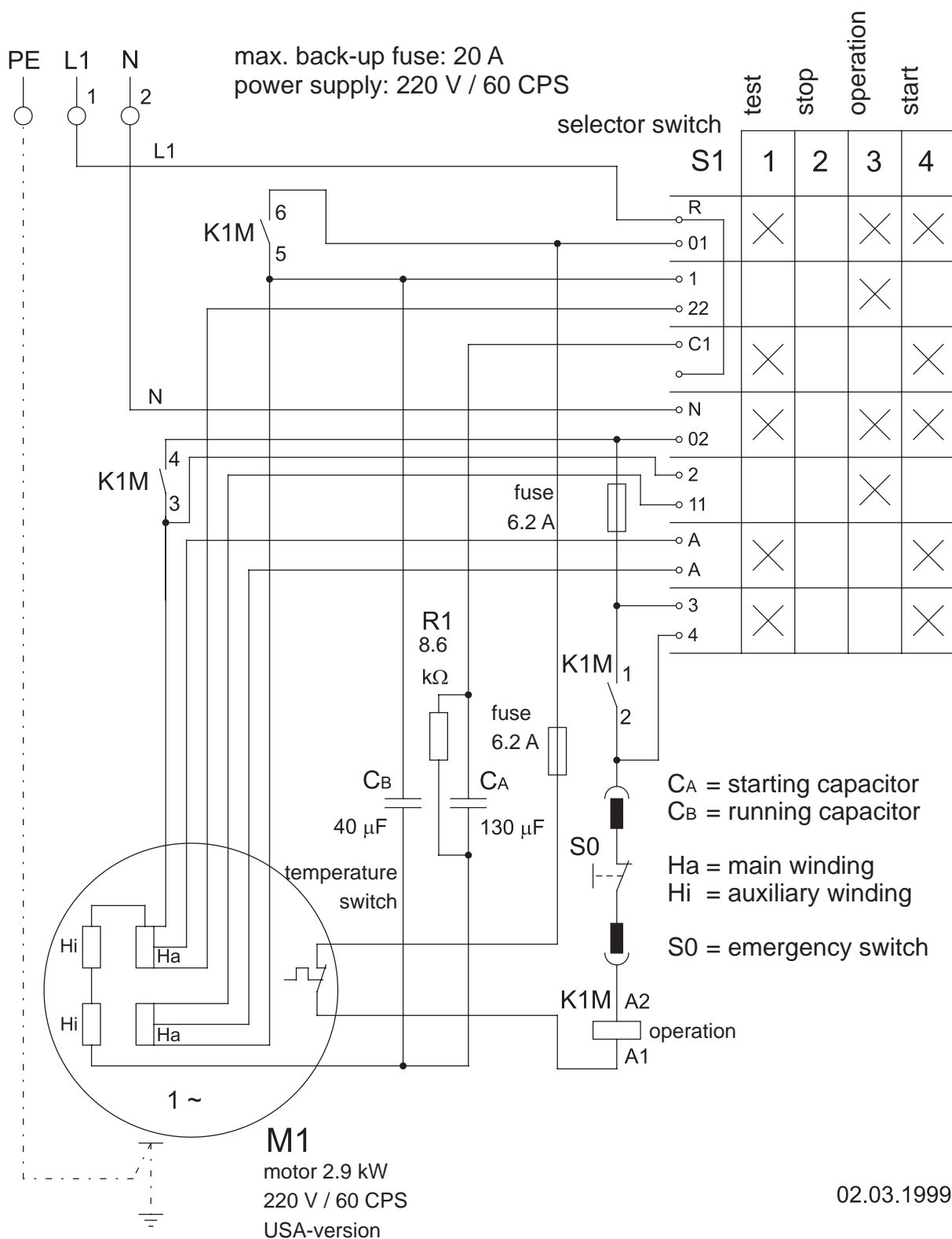

HUMMEL + ELF: single-phase AC motor		2.9 kW / 220 V / 60 CPS USA-version
EUGEN LÄGLER GMBH Industriegebiet Kappelrain D-74363 Güglingen-Frauenzimmern	Telefon: +49 - 7135 - 98 90 - 0 Fax: +49 - 7135 - 98 90 - 98	E-Mail: info@laegler.com Internet: http://www.laegler.com

The circuit diagram valid for your machine is located in the motor switch box.

SPARE PARTS

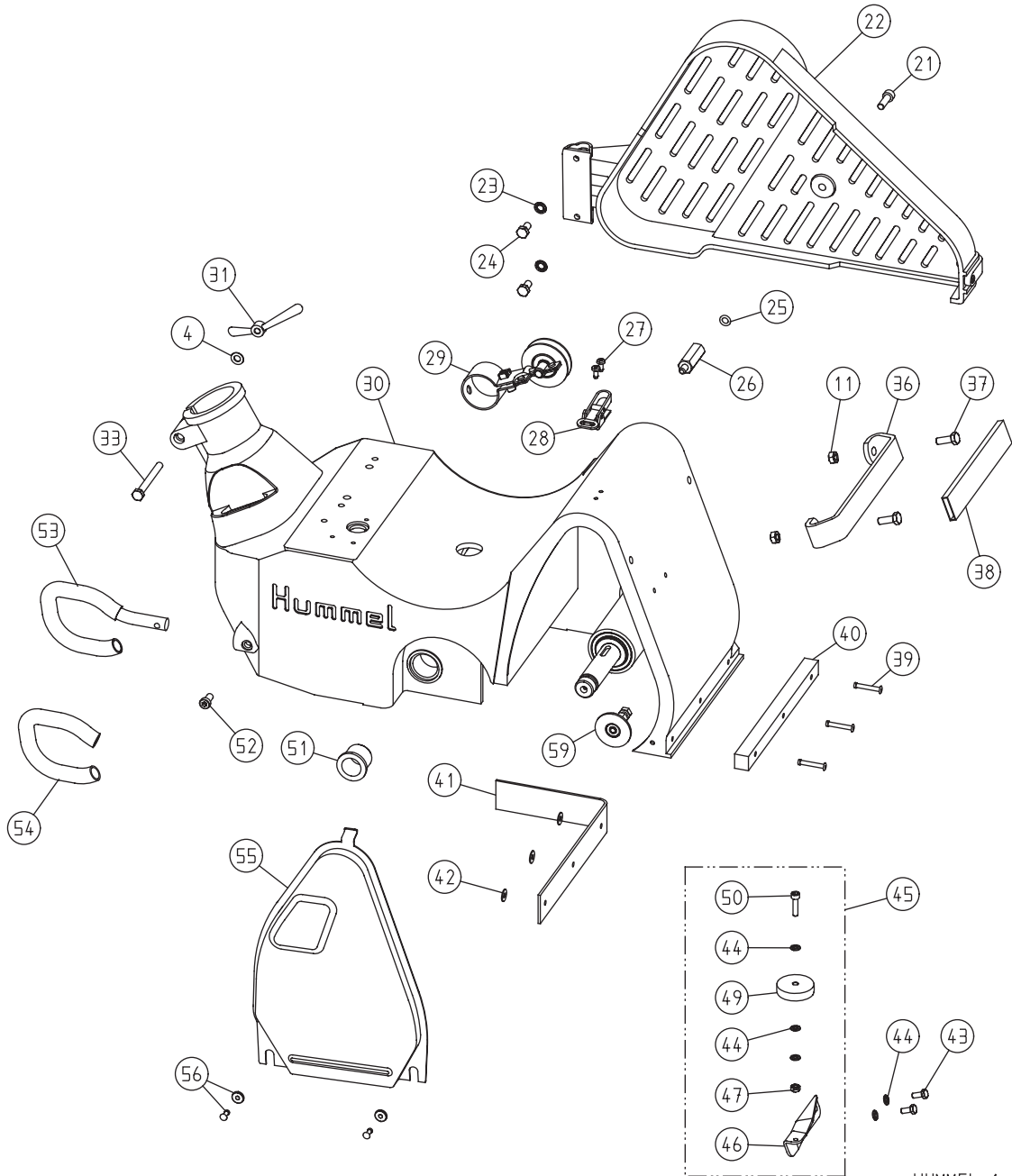

HUMMEL 1
01.05.2005

SPARE PARTS

Pos.	Product-No.	Description
4	0125.1008.000	Washer
11	0980.1008.000	Nut
21	0912.1008.025	Hexagonal socket head screw
22	100.50.00.100	Belt guard, complete
23	6797.1008.000	Toothed lock washer
24	0933.1008.016	Hexagonal head screw
25	000.01.40.001	O-ring
26	100.50.04.105	Screw stud
27	7500.1005.012	Lens head screw
28	100.01.05.105	Cover fastener
29	100.58.00.200	Belt tensioner, complete
30	100.01.00.100	Housing
31	000.20.45.083	Wing nut
33	0931.1008.075	Hexagonal head screw
36	100.33.01.100	Bracket
37	0933.1008.022	Hexagonal head screw
38	100.33.02.100	Grip
39	7337.1005.033	Rivet
40	100.01.01.100	Bumper felt
41	100.01.02.100	Sealing felt
42	9021.1005.000	Washer
43	0933.1006.014	Hexagonal head screw
44	0125.1006.000	Washer
45	100.60.00.200	Wall protecting roller with bracket
46	100.60.01.100	Bracket
47	0934.1006.000	Nut
49	100.60.02.200	Wall protecting roller
50	0912.1006.025	Hexagonal socket head screw
51	000.43.10.252	Plastic bushing
52	7984.1008.016	Hexagonal socket head screw
53	100.44.00.100	Safety guard, complete
54	100.44.01.100	PVC tube
55	100.01.03.100	Side cover
56	100.01.08.200	Collar nut, complete
59	100.01.30.100	Guide roller, complete

SPARE PARTS

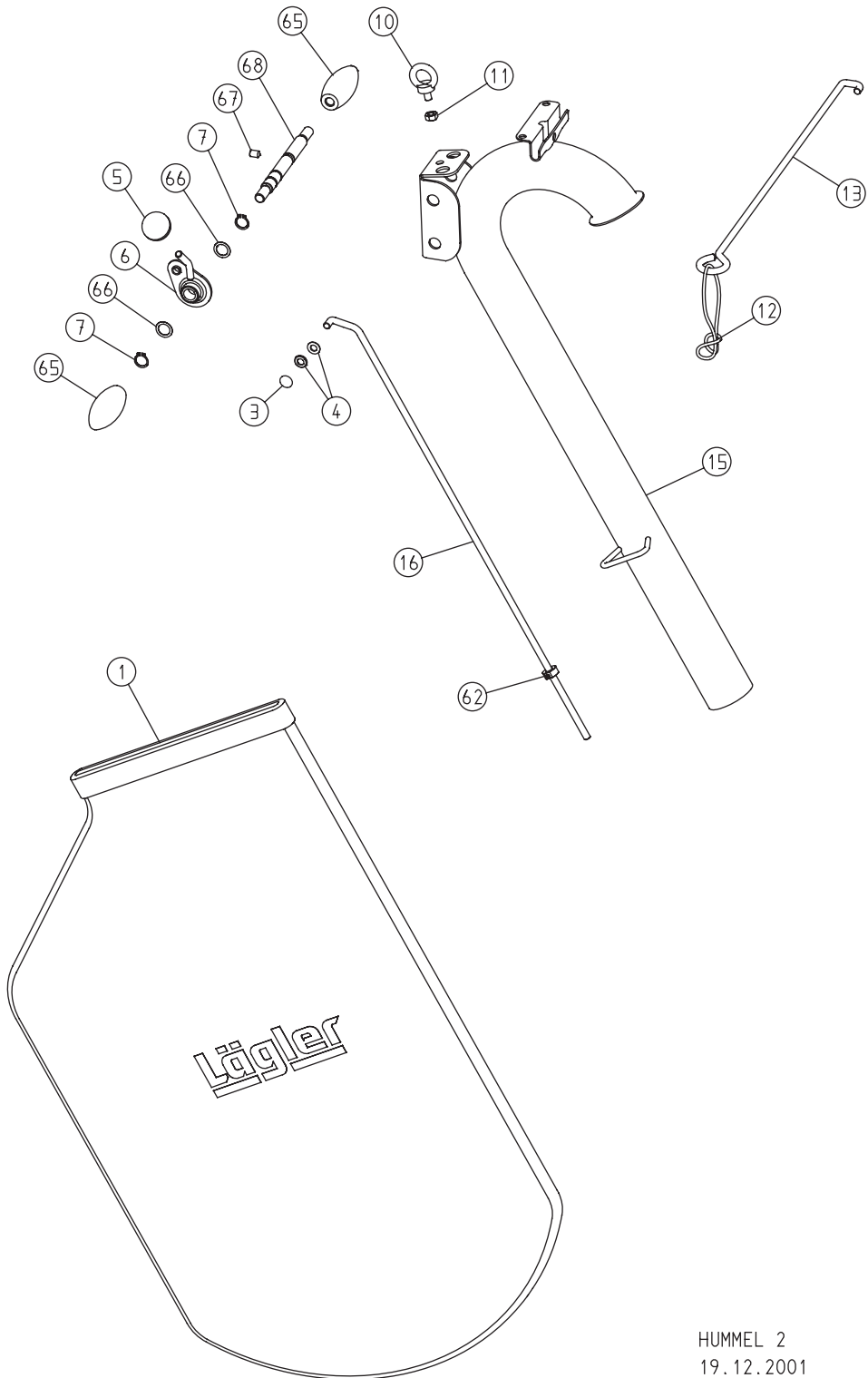

SPARE PARTS

Pos.	Product-No.	Description
1	100.00.80.105	Dust bag HUMMEL
3	000.17.21.081	Fixing cap
4	0125.1008.000	Washer
5	000.20.56.351	Ball knob
6	100.20.18.200	Lever
7	0471.0015.000	Circlip
10	0580.1008.000	Thread eye
11	0980.1008.000	Nut
12	000.01.40.011	Strain relief ring
13	100.20.26.100	Cable support, complete
15	100.20.01.200	Guide tube
	102.20.01.200	Guide tube USA
	100.20.00.200	Guide tube, complete
	102.20.00.200	Guide tube USA, complete
	100.21.00.200	Guide tube long, complete
16	100.20.24.100	Upper rod, complete
62	100.20.23.100	Adjusting ring, complete
65	000.20.31.351	Handle
66	0988.0015.005	Precision washer
67	0914.0008.012	Grub screw
68	100.20.17.200	Axle for handle

SPARE PARTS

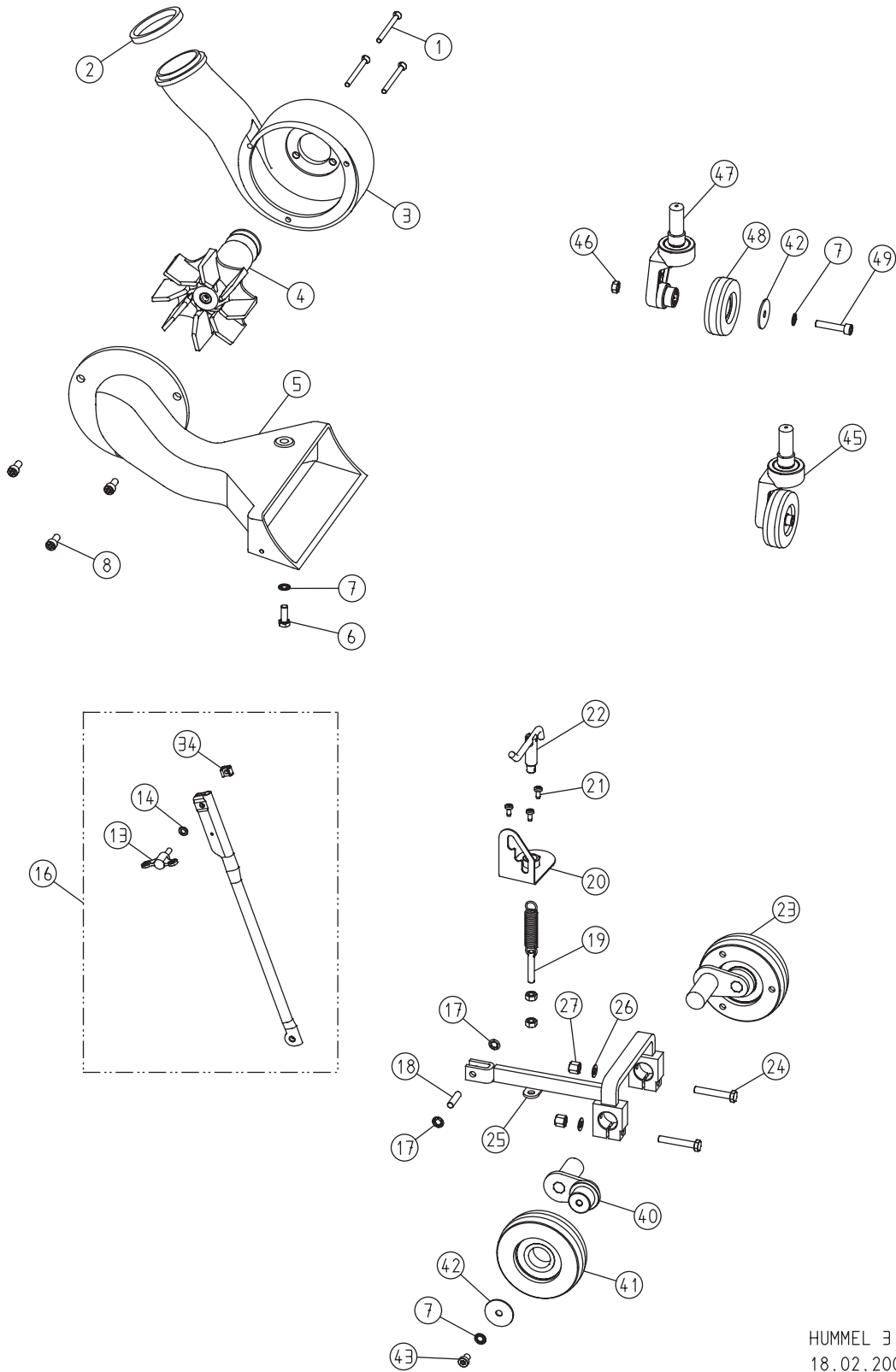

HUMMEL E
18.02.2002

SPARE PARTS

Pos.	Product-No.	Description
1	0965.1006.070	Countersunk head screw
2	100.08.01.200	Sealing ring
3	100.08.00.100	Fan housing
4	100.10.00.200	Fan insert, complete
5	100.14.00.100	Intake duct
6	0933.1008.022	Hexagonal head screw
7	6797.1008.000	Toothed lock washer
8	0912.1008.018	Hexagonal socket head screw
13	000.20.46.062	Wing screw
14	0125.1006.000	Washer
16	100.04.09.100	Lower rod, complete
17	000.17.20.081	Quick-fixing-fastener
18	100.04.01.200	Pivot pin
19	100.04.25.100	Tension spring complete with screw
20	100.04.06.200	Notch plate
21	7500.1005.012	Lens head screw
22	100.04.02.100	Spring tensioner, complete
23	100.05.00.200	Lateral wheel, complete
24	0931.1008.050	Hexagonal head screw
25	100.04.00.100	Lifting fixture
26	0125.1008.000	Washer
27	6330.1008.000	Nut
34	000.50.12.061	Exchangeable nut
40	100.05.04.200	Wheel arm
41	100.05.29.100	Lateral wheel
42	000.10.10.085	Washer
43	7984.1008.012	Hexagonal socket head screw
45	100.18.00.300	Rear wheel, complete
46	0934.1008.000	Nut
47	100.18.18.300	Yoke housing, complete
48	100.18.29.105	Rear wheel
49	0912.1008.040	Hexagonal socket head screw

SPARE PARTS

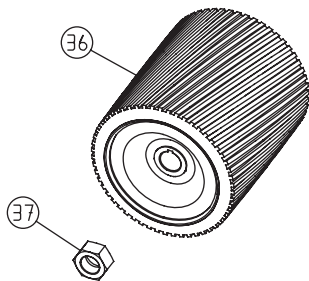
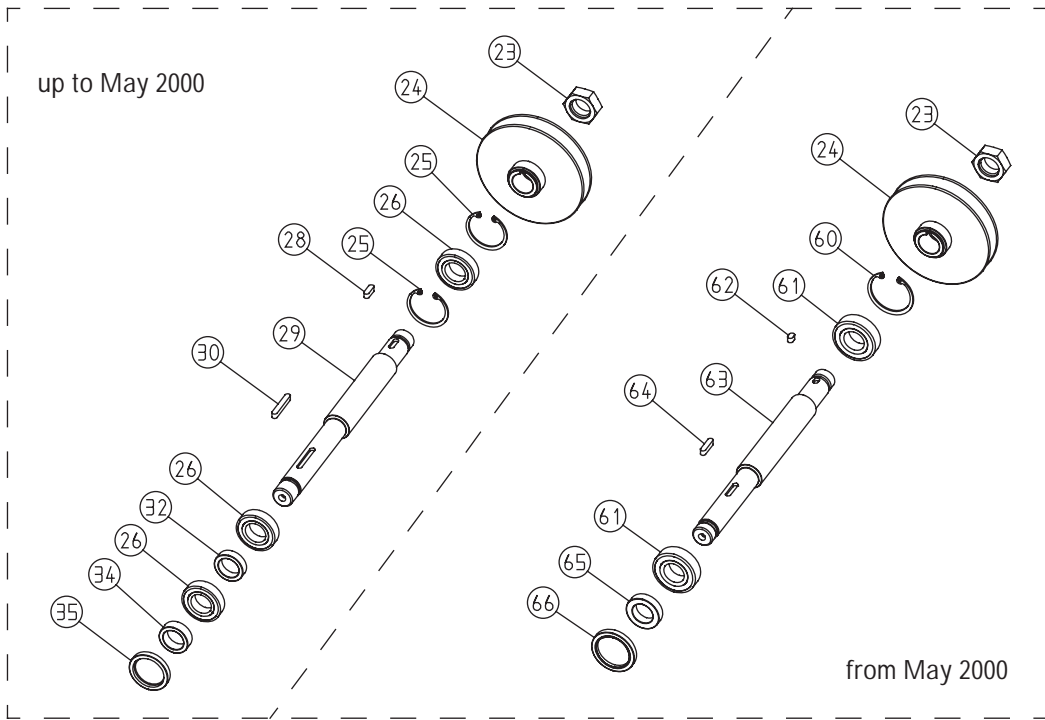
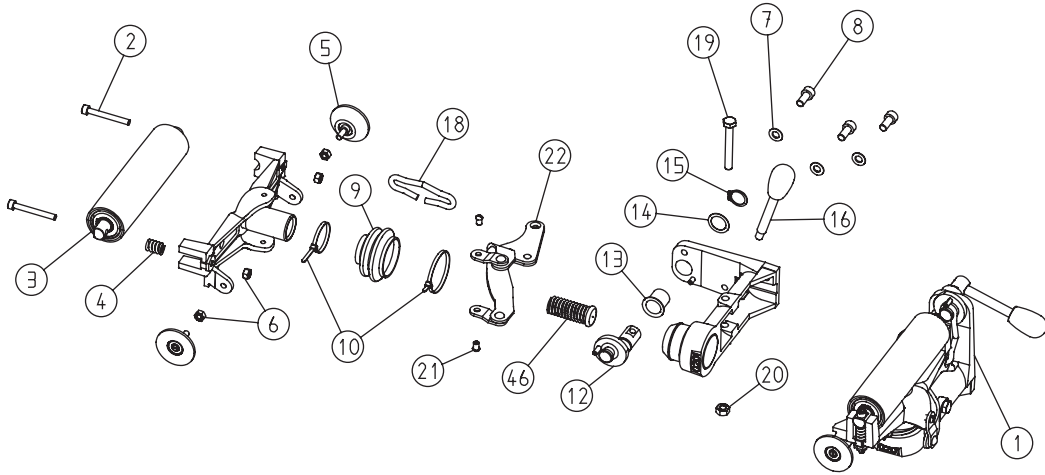

Please state the machine number with each order.

HUMMEL 4
12.02.2001

SPARE PARTS

Pos.	Product-No.	Description
1	100.45.00.100	Drive unit, complete
2	0912.1006.050	Hexagonal socket head screw
3	100.45.12.105	Tensioning roller
4	000.31.13.021	Compression spring
5	100.45.01.105	Guide roller
6	0980.1006.000	Nut
7	0125.1008.000	Washer
8	0912.1008.018	Hexagonal socket head screw
9	100.45.81.105	Collar
10	000.61.10.363	Nylon fastener
12	100.45.20.100	Crank
13	100.45.24.105	Bearing bush
14	0988.0018.005	Precision washer
15	0471.0018.000	Circlip
16	000.20.32.104	Operating lever
18	100.45.17.100	Clip
19	0931.1008.060	Hexagonal head screw
20	0980.1008.000	Nut
21	100.45.61.105	Roundhead screw
22	100.45.37.100	Double arm, complete
23	100.02.05.100	Hexagonal nut, right-hand thread
24	100.36.00.100	V-belt pulley
25	0472.0047.000	Circlip
26	6005.0025.205	Ball bearing
28	6885.0606.018	Key
29	100.02.01.100	Sanding shaft
30	6885.0606.040	Key
32	100.02.04.105	Spacer ring
34	100.02.03.105	Slide ring
35	000.11.35.102	Shaft seal
36	120.40.00.100	Sanding drum HUMMEL
	120.41.00.100	Sanding drum HUMMEL, hard rubber cover
37	100.02.06.100	Hexagonal nut, left-hand thread
46	100.45.45.100	Compression spring
60	0472.0052.000	Circlip
61	6205.0025.205	Ball bearing
62	6885.0606.010	Key
63	100.02.01.200	Sanding shaft
64	6885.0606.025	Key
65	100.02.03.200	Spacer ring
66	000.11.40.102	Shaft seal

SPARE PARTS

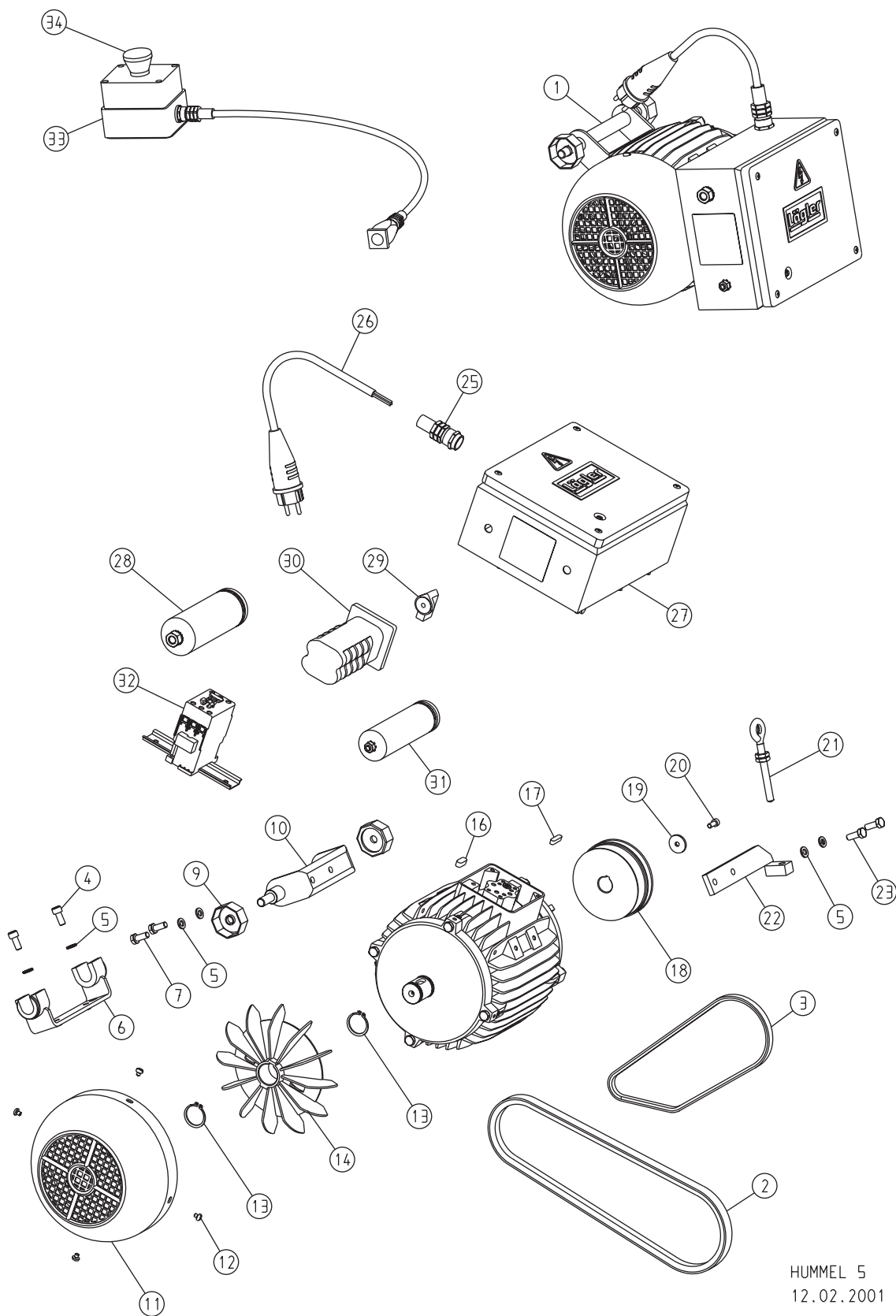

HUMMEL 5
12.02.2001

SPARE PARTS

Pos.	Product-No.	Description
1	100.65.00.100	Single-phase AC motor new, 230 V / 50 CPS / 2.2 kW
	101.65.00.100	Single-phase AC motor new, 230 V / 60 CPS / 2.2 kW
	102.65.00.100	Single-phase AC motor new, 220 V / 60 CPS / 2.9 kW, USA
	105.65.00.100	Three-phase AC motor new, 400 V / 50 CPS / 4 kW
2	000.71.26.087	V-belt 17 x 875
3	000.71.24.065	V-belt 10 x 650
4	0912.1008.020	Hexagonal socket head screw
5	0127.1008.000	Spring washer
6	100.65.29.200	Motor bearing bracket
7	0933.1008.020	Hexagonal head screw
9	100.65.30.100	Motor nut
10	100.65.25.100	Motor mounting
11	100.65.09.100	Fan cover
12	7500.1005.006	Lens head screw
13	0471.0030.000	Circlip
14	100.65.08.105	Fan wheel
16	6885.0807.020	Key
17	6885.0606.025	Key
18	100.65.06.100	Motor pulley
19	000.10.10.061	Lock washer
20	0912.1006.014	Hexagonal socket head screw
21	100.65.80.105	Eye bolt
22	100.65.35.100	Motor tensioner
23	0933.1008.022	Hexagonal head screw
25	000.67.20.161	Strain relief unit
26	000.65.43.251	Motor cable 3 x 2.5 mm ²
	000.65.43.257	Motor cable 3 x 2.5 mm ² , USA
	000.65.45.151	Motor cable 5 x 1.5 mm ² , three-phase AC motor
27	100.65.40.100	Switchbox, 230 V / 50 CPS
	102.65.40.100	Switchbox, 220-230 V / 60 CPS + three-phase AC current
28	000.65.10.041	Running capacitor
29	000.65.62.211	Switchknob
30	000.65.60.253	Switch
	000.65.60.401	Switch three-phase AC motor
31	000.65.10.061	Starting capacitor
	000.65.10.131	Starting capacitor USA
32	000.65.20.035	Universal contactor
	000.65.20.032	Universal contactor complete, three-phase AC motor
33	102.65.60.100	Emergency switch
34	000.65.62.221	Red button for emergency switch

SPARE PARTS

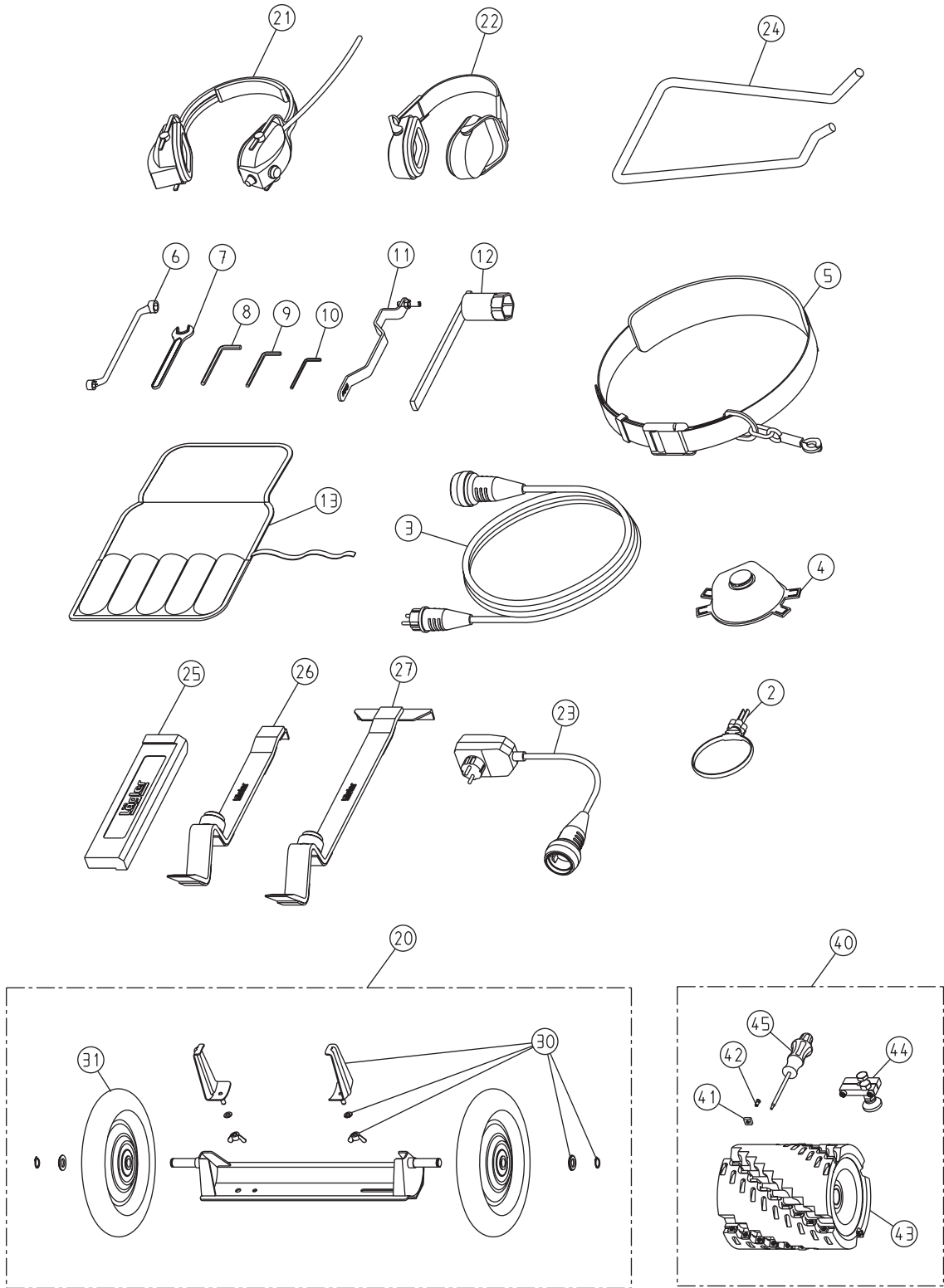

HUMMEL 6
12.02.2001

SPARE PARTS

Pos.	Product-No.	Description
2	000.01.40.110	MultiClip
3	000.65.53.251	Extension cable 3 x 2.5 mm ² , 10 m long
	000.65.53.252	Extension cable 3 x 2.5 mm ² , 20 m long
	000.65.55.151	Extension cable 5 x 1.5 mm ² , 10 m long, three-phase AC motor
4	000.01.20.010	Protective mask P3
5	000.01.50.010	Safety belt
6	000.95.21.103	Closed mouth wrench
7	000.95.11.171	Open mouth wrench
8	000.93.11.061	Hexagonal socket screw wrench 6 mm
9	000.93.11.051	Hexagonal socket screw wrench 5 mm
10	000.93.11.041	Hexagonal socket screw wrench 4 mm
11	100.00.50.100	Setting fixture
12	100.00.45.105	Box wrench
13	000.01.30.011	Tool bag, empty
	100.98.00.100	Tool bag, complete
20	720.00.00.200	Trolley TRANSCART, complete
21	000.01.10.011	Foldable earmuff type MUSIMUFF
22	000.01.10.021	Foldable earmuff type POCKET
23	000.01.65.010	DI-safety plug
24	100.00.55.100	Carrying handle HUMMEL
25	701.10.00.100	Impact tool
26	702.00.00.100	Parquet layer tool 43 cm long
27	703.00.00.100	Parquet layer tool 55 cm long
30	720.10.00.200	Accessories TRANSCART
31	720.05.00.205	Wheel TRANSCART
40	000.10.42.240	Milling drum 200 mm width, complete with accessories
41	900.02.45.105	Carbide tool (10 pcs. per box)
42	900.02.47.105	Screw for blade
43	000.10.42.241	Milling drum with carbide blades
44	000.10.42.243	Cutting depth adjustment, complete
45	000.91.30.151	Torx screw driver

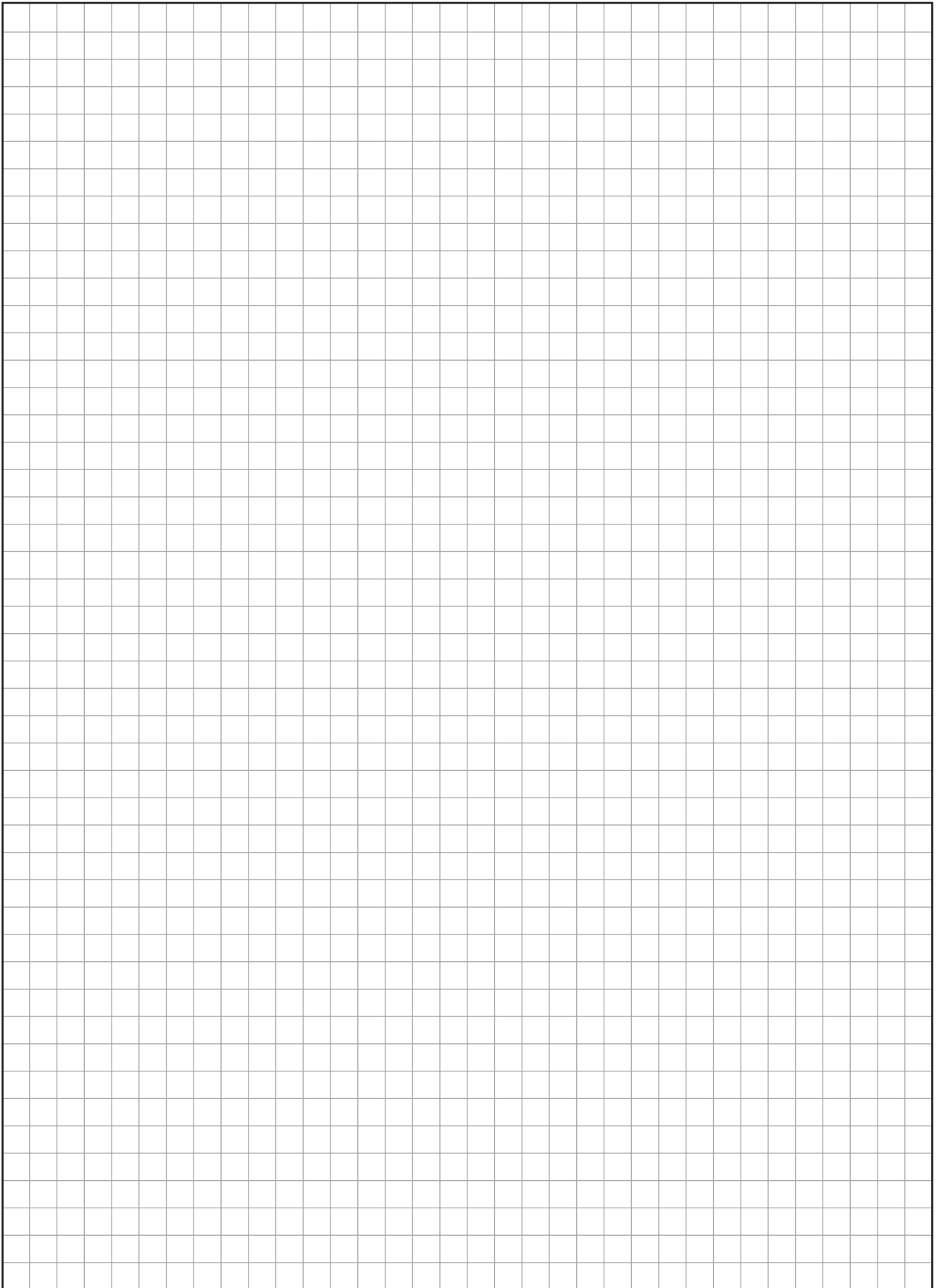

SERVICE PASSPORT

SERVICE PASSPORT

On the back of these operating instructions, please enter the serial number and the year of construction of your machine (see rating plate). Otherwise your service passport will not be valid.

Be sure that any kind of maintenance work is certified here by your dealers company.

Date of test
and service: _____

Signature and stamp

Date of test
and service: _____

Signature and stamp

Date of test
and service: _____

Signature and stamp

Date of test
and service: _____

Signature and stamp

Date of test
and service: _____

Signature and stamp

Date of test
and service: _____

Signature and stamp

Date of test
and service: _____

Signature and stamp

Date of test
and service: _____

Signature and stamp

Date of test
and service: _____

Signature and stamp

Date of test
and service: _____

Signature and stamp

Date of test
and service: _____

Signature and stamp

Date of test
and service: _____

Signature and stamp

Date of test
and service: _____

Signature and stamp

Date of test
and service: _____

Signature and stamp

Date of test
and service: _____

Signature and stamp

Declaration of conformity as defined by EC Directives

98/37/EC dated June 22, 1998

Low Voltage Directive (73/23/EEC, last amended by 93/68/EEC dated June 22, 1993)

Electromagnetic compatibility Directive (89/336/EEC, last amended by 93/68/EEC dated June 22, 1993)

The LÄGLER HUMMEL type belt sanding machine, serial no. please see rating plate, has been developed, designed and produced in agreement with the above Directives.

The following harmonized standards have been used:

DIN EN 292 Part 1 and Part 2, Safety of machinery

DIN EN 60 204.1, Safety of electrical equipment of machines

EN 55014-1, Electromagnetic compatibility: Emission-product family standard

EN 55014-2, Electromagnetic compatibility: Immunity-product family standard

EN 61000-3-2, Electromagnetic compatibility: Limits for current harmonic emissions

EN 61000-3-3, Electromagnetic compatibility: Limitation of voltage fluctuations and flicker in low-voltage supply systems for equipment with rated current up to and including ≤ 16 A

The following documents are provided:

- Overall plan of the machine with control circuit diagrams
- Detailed complete plans to permit review of machine compliance with the underlying safety and health requirements
- A list of underlying requirements derived from EC directives, standards and specifications taken into account in the design of the machine.
- A description of solutions for the prevention of risk emanating from the machine
- A copy of the machine operating instructions.

Eugen Lägler GmbH · Maschinenbau
Industriegebiet Kappelrain
D-74363 Göglingen-Frauenzimmern
Phone: +49 - 7135 - 98 90-0 · Fax: +49 - 7135 - 98 90-98
E-Mail: info@laegler.com · <http://www.laegler.com>

Volker Wörner

Dipl.-Ing. (FH) Volker Wörner, Design Engineer
Eugen Lägler GmbH, Maschinenbau
Göglingen-Frauenzimmern,
dated 01.05.2005

HUMMEL

Serial No: _____

Year of construction: _____



Lägler

WORLD LEADERS IN FLOOR
SANDING TECHNOLOGY

Eugen Lägler GmbH · Maschinenbau

Industriegebiet Kappelrain · D-74363 Göglingen-Frauenzimmern

Telefon: +49 - 7135 - 98 90-0 · Telefax: +49 - 7135 - 98 90-98 · E-Mail: info@laegler.com · <http://www.laegler.com>