

Dimensions

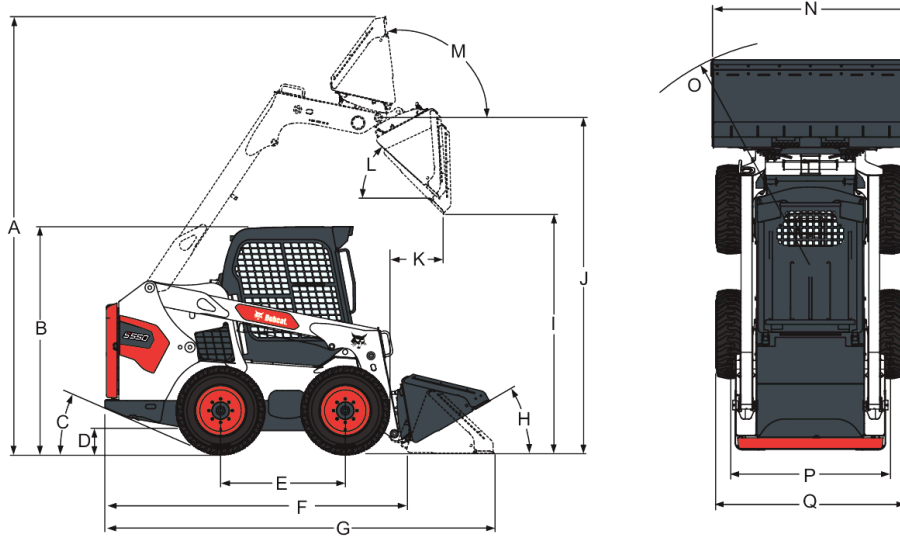

(A) Operating height	3787.0 mm
(B) Height with operator cab	1972.0 mm
(C) Angle of departure	24.2°
(D) Ground clearance	185.0 mm
(E) Wheelbase	1082.0 mm
(F) Length without attachment	2657.0 mm
(G) Length with standard bucket	3378.0 mm
(H) Rollback at ground position	30.0°
(I) Dump height with standard bucket	2205.0 mm
(J) Height to bucket hinge pin	2908.0 mm
(K) Dump reach at maximum height	467.0 mm
(L) Dump angle at maximum height	42.0°
(M) Rollback fully raised at maximum height	97.0°
(N) Width over standard bucket	1727.0 mm
(N) Bucket width, 62-inch	1575.0 mm
(N) Bucket width, 74-inches	1880.0 mm
(O) Turning radius with standard bucket	2032.0 mm
(P) Track, standard tyres	1374.0 mm
(Q) Width over standard tyres	1643.0 mm
(Q*) Width over tyres, 10 x 16.5, 10-ply, Heavy duty, offset rims	1520.0 mm

Performance

Tipping load (ISO 14397-1)	1852 kg
Rated operating capacity (ISO 14397-1)	926 kg
Lift breakout force	1978 daN
Tilt breakout force	2080 daN
Push Force	2377 daN
Axle torque	5423.0 Nm

Cycle Times

Raise lift arms	3.6 s
Lower lift arms	3.6 s
Bucket rollback	1.7 s
Bucket dump	2.5 s

Weights

Operating weight	2995 kg
Shipping weight	2612 kg

Engine

Make / Model	Bobcat 2.4L, 97/68 EC Stage V
Fuel	Diesel
Cooling	Liquid
Power at 2600 RPM:	50.7 kW
Rated speed (EEC 80/1269, ISO 9249)	2600.0 RPM
Torque at 1800 RPM (SAE J1995 Gross):	252.0 Nm
Number of cylinders	4
Displacement	2392 cm ³
Bore	90.0 mm
Stroke	94.0 mm
Lubrication	Gear pump pressure
Crankcase ventilation	Closed breathing
Air filter	Dry replaceable cartridge with safety element
Ignition	Diesel-compression
Starting aid	Glow plugs

Electrical

Alternator	90 A — open frame with internal regulator
Battery	12 V — 600 A cold cranking at -18°C — 115 min reserve capacity at 25 A
Starter	12 V — gear reduction type — 2.7 kW (3.6 hp)

Hydraulic System

Pump type	Engine driven, gear type
Pump capacity	64.70 L/min
Pump capacity (with high flow option)	101.10 L/min
System relief at quick couplers	23.8-24.5 MPa
Control valve	Three-spool, open-centre type with float detent on lift and electrically controlled auxiliary spool
Hydraulic filter	Full-flow replaceable — 10 µm synthetic media element
Fluid lines	SAE standard tubelines, hoses, and fittings

Hydraulic Cylinders

Lift cylinder (2)	Double-acting
Lift cylinder bore	57.2 mm
Lift cylinder rod	38.1 mm
Lift cylinder stroke	698.5 mm
Tilt cylinder (2)	Double-acting
Tilt cylinder bore	69.9 mm
Tilt cylinder rod	38.1 mm
Tilt cylinder stroke	330.7 mm

Drive System

Transmission	Infinitely variable tandem hydrostatic piston pumps, driving two fully reversing hydrostatic motors
Final drive chains	Pre-stressed #80 HSOC endless roller chain (no master link) and sprockets in sealed chaincase with oil lubrication. (Chains do not require periodic adjustments.) Two chains per side with no idler sprocket.
Main drive	Fully hydrostatic; four-wheel drive
Axle size	50.3 mm, heat treated. Axle tubes welded to chaincase. Labyrinth axle seal protection.
Wheel bolts	Eight 9/16–inch wheel bolts fixed to axle hubs

Traction

Max. travel speed (low range)	11.8 km/h
Max. travel speed (high range - option)	17.3 km/h
Gradeability	20° Continuous and 30° Intermittent

Fluid Capacities

Chaincase reservoir	32.20 L
Cooling system	10.60 L
Cooling system with heater	10.90 L
Engine oil with filter	8.60 L
Fuel tank	93.70 L
Hydraulic reservoir	7.57 L
Hydraulic / Hydrostatic system	32.20 L

Fluid Specifications

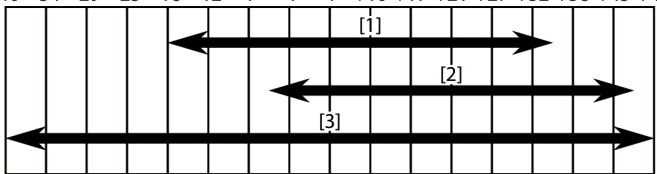
Engine coolant	Propylene glycol/water mix (53% - 47%) with freeze protection to -37°C 5 L can - 6904844A, 25 L container - 6904844B, 209 L drum - 6904844C, 1000 L tank - 6904844D
Engine oil	Refer to temperature range anticipated before next oil change. Must use API Category CI-4 or better, or ACEA E7 or better. Do not use API Category FA-4 engine oil. (°C) -40 -34 -29 -23 -18 -12 -7 -1 4 +10 +17 +21 +27 +32 +38 +43 +49 
Hydraulic fluid	[1] SAE 10W-30 [2] SAE 15W-40 [3] Bobcat Synthetic Oil – SAE 5W-40 Bobcat engine oils are recommended for use in this machine. If Bobcat engine oil is not available, use a good quality engine oil that meets API Service Category of CI-4 or better, or ACEA E7 or better * Can be used only when available with appropriate diesel rating. For synthetic oil use the recommendation from the oil manufacturer. Bobcat Superior SH, 5 L can - 6904842A, 25 L container - 6904842B, 209 L drum - 6904842C, 1000 L tank - 6904842D Bobcat Bio Hydraulic, 5 L can - 6904843A, 25 L container - 6904843B, 209 L drum - 6904843C, 1000 L tank - 6904843D Motor oil is not an acceptable alternative fluid.

Controls

Engine Starting	Hand throttle or optional foot accelerator pedal (SJC)
Front auxiliary (standard)	Keyless start. Glow plugs automatically activated.
Rear auxiliary (optional)	Selectable Joystick Controls (SJC) or optional Proportional switch on Hand Levers
Loader hydraulics tilt and lift	Electrical switch on left-hand steering lever or joystick (SJC)
Service brake	Selectable Joystick Controls (SJC) or optional Foot Pedals
Parking brake	Two independent hydrostatic systems controlled by two hand operated steering levers or optional joystick(s) (SJC)
Parking brake, two-speed option	Mechanical disc activated by manually operated switch on left instrument panel
Vehicle steering	Spring applied, pressure released multi-disk brake activated by rocker switch
Auxiliary pressure release	Selectable Joystick Controls (SJC) or optional Hand Levers
	Pressure is relieved through the coupler block. Push in and hold for 5 s.

Instrumentation

The following loader functions are monitored by a combination of gauges and warning lights in the operator's line of sight. The system alerts the operator of monitored loader malfunctions by way of audible alarm and visual warning lights.

Standard Instrument Panel

- Gauges
 - Engine coolant temperature
 - Fuel
- Indicators
 - Bobcat Interlock Control System
 - Engine preheat
 - Two speed
 - Turn signals
- Warning lights
 - Engine coolant temperature
 - Fuel level
 - General warning
 - Seat belt
 - Seatbar down
 - Engine malfunction
 - Hydraulic system malfunction
 - Lift and tilt valve, hydraulics lock-out
 - Parking brake
 - Hydraulic oil temperature
 - Engine oil pressure
 - Hydraulic oil pressure
- Buttons
 - Work lights and road lights
 - High flow auxiliary hydraulics
 - Auxiliary hydraulics
 - Information (Hour meter, Engine RPM, Battery voltage, Service codes, Service reminder, Maintenance clock)
 - Traction lock override
 - Press to operate loader
- Rocker switch
 - Parking brake
- Alarm
 - Beep when error, warning or shutdown condition exists

Deluxe Instrument Panel

Same gauges, warning lights and other features as Standard Instrument Panel, plus:

- Gauges
 - Engine oil pressure / temperature
 - Hydrostatic charge pressure
 - Hydraulic oil temperature
 - Battery

- Additional features
 - Keyless start with password capability
 - Digital clock
 - User name and hourmeter
 - Attachments control information
 - Current job hours
 - High Flow lockouts
 - Multi-language display
 - Help screens
 - Auto Idle
 - DPF Management
 - Diagnostic capability
 - Engine/hydraulic systems shutdown function
 - Password lockout
- Icons
 - Active warnings
 - Vitals (Engine speed, Oil Pressure, Temperature, System voltage, Hydraulic charge pressure, Oil temperature)
 - Service
 - Main screen
 - Attachments
 - Security
 - DPF Regeneration
 - HEST Lamp
 - Inhibit DPF Regeneration
 - Forced Parked Regeneration
 - Display
- Buttons
 - Left scroll
 - Enter
 - Right scroll

Serviceability

Access is available to the following through the rear door/tailgate and rear screen:

- Air cleaner
- Alternator
- Battery
- Cooling radiators
- Engine oil and fuel filters
- Engine oil drain and dipstick
- Hydraulic oil fill
- Starter

Axle hubs provide protection for the axle seals

Bob-Tach™ pivots have replaceable wear bushings

Easy access to all grease points

Rod end of the tilt cylinder has a replaceable bushing

Tailgate has an optional lock for vandal-proofing

Tailgate is equipped with door-stop to hold door open while servicing

Tip-up operator cab gives access to certain hydraulic system components

Standard Features

- 10 x 16.5, 10-ply, Versatile duty tyres
- Selectable Joystick Controls (SJC - R/C Ready)

- High-flow auxiliary hydraulics
- 7-pin attachment control
- 2 Speed
- Bobcat Interlock Control System (BICS)
- Parking brake
- Deluxe operator cab* Includes interior cab foam, side, top and rear windows, Deluxe wire harness, dome light and electrical power port ¹
- Noise reduction kit
- Operating lights, front and rear
- Deluxe instrument panel
- Keyless start with password capability
- Suspension seat
- Seat belt
- Seat bar
- Hydraulic bucket positioning (including ON/OFF switch)
- Bob-Tach™ frame
- Cushioned lift and tilt cylinders
- Lift arm support
- Engine/hydraulics system shutdown
- Spark Arrester
- Automatically activated glow plugs
- Electrically activated proportional front auxiliary hydraulics
- Auxiliary hydraulics: variable flow/maximum flow
- Machine IQ (telematic)
- Manual
- CE certification
- Warranty: 24 months or 2000 hours (whichever occurs first)

Options

- Factory Options
 - Deluxe pressurized cab with heating
 - Deluxe pressurized cab with HVAC
 - Cloth Suspension Seat
 - 10 x 16.5, 10-ply, Heavy duty tyres, offset rims
 - 31 x 12-16.5, 10-ply, Superflotation tyres
 - 10 x 16.5, 10-ply, Severe duty tyres
 - 31 x 10 - 20, Industrial duty tyres
 - Power Bob-Tach™
 - Back-up alarm
 - Radio
 - Beacon
 - Work Lights LED
 - Strobe
 - Road Option
 - Automatic Ride Control
 - Automatic Reversing Fan
 - Custom paint color (min order of 5 units)

1. Roll Over Protective Structure (ROPS) – meets requirements of SAE-J1040 and ISO 3471; Falling Object Protective Structure (FOPS) - meets requirements of SAE-J1043 and ISO 3449, Level I

- Dealer Installed Options
 - Cab enclosure kit
 - Special applications front door kit
 - 200 lbs (74.4 kg) counterweight kit
 - Front axle counterweight kit
 - Fuel cap locking kit
 - Deluxe instrument panel
 - Replacement Bob-Tach™
 - Fresh air heater kit
 - Front door kit
 - Door sensor kit
 - Plumbing kit for fresh air heater
 - Back up alarm kit
 - FOPS kit **
 - Single-point lift kit
 - Power Bob-Tach™ kit
 - Operator cab, CE, enclosure kit
 - 7-pin attachment control
 - Four-point lift kit
 - Rear auxiliary hydraulic kit
 - Engine block heater kit
 - Road kit
 - Bucket positioning kit
 - Keyless kit
 - Rear window wiper kit
 - 14-pin attachment control kit
 - 4-Way flasher kit
 - 80 mm Suspension seat kit
 - Cup holder kit
 - Headlight guard kit
 - Muffler guard kit
 - Tail light guard kit

Attachments

- Auger Accessories
- Augers
- Backhoes
- Bale Forks
- Box Blades
- Breaker Accessories
- Breakers
- Brushcat™ Rotary Cutters
- Brush Saws
- Combination Buckets
- Concrete Mixers
- Concrete Pumps
- Construction / Industrial Buckets
- Diggers
- Dozer Blades
- Drop Hammers
- Dumping Hoppers
- Flail Cutters
- Planer Accessories
- Planers
- Rear Stabilizers
- Remote Control
- Root Grapples
- Scarifiers
- Scrapers
- Seeders
- Skeleton Buckets
- Snow Blades
- Snow Pushers
- Snow V-Blades
- Sod Layers
- Soil Conditioners
- Spreader
- Spreaders
- Steel Tracks
- Stump Grinders

- Graders
- Grapples, Industrial
- Landplanes
- Landscape Rakes
- Laser Equipment
- Low Profile Buckets
- Miscellaneous
- Mixing Buckets
- Mowers
- Pallet Fork Accessories
- Pallet Forks, Hydraulic
- Sweepers
- Tillers
- Tilt-Tatch
- Tree Transplanters
- Trench Compactors
- Trenchers
- Utility Forks
- Utility Frames
- Vibratory Rollers
- Wheel Saws
- Wood Chippers

Environmental

Operator LpA(98/37 & 474-1)	86 dB(A)
Noise level LWA(EU Directive 2000/14/EC)	101 dB(A)
Whole body vibration (ISO 2631-1) High speed	0.89 ms ⁻²
Whole body vibration uncertainty	0.45 ms ⁻²
Hand-arm vibration (ISO 5349-1) High speed	1.58 ms ⁻²