

SL 280 Standard
– handy and compact

SL 280 Standard

for indoor use



Lifts and handles elements up to 280 kg

SL 280 Standard is a compact and robust lifting device with a tight turning radius. This Smartlift has been designed with an electric lifter and electric telescopic arm – which extends up to 50 cm.

- Two vacuum circuits with two pumps
- Accurate to the millimeter
- Handy and compact
- Multifunctional
- Self-propelled
- Tried-and-tested Danish quality

A versatile and flexible lifting device.



The SL 280 Standard is available with a special device for the handling of other materials.



N.A. Christensensvej 39
DK-7900 Nykøbing Mors
Tel.: +45 97 72 29 11
E-mail: smart@smartlift.dk
www.smartlift.dk

Smart Lift
DENMARK

This Smartlift can be shifted sideways for final precise corrections prior to installation.



The lifting device has a multifunctional swivel head.



The Smartlift is easy to transport in a van or on a trailer.

Technical data

Description	Value
Weight	470 kg
Height	1320 mm
Width (min)	620 mm
Length (min)	1400 mm
Extension of arm	500 mm
Tip from horizontal	50° back/50° forward
Sideshift	100 mm
Vacuum system	2-circuit
Charging voltage	230 volt
Integrated charger	Cetek XT 14000
Charging time	Approx 8 hours
Battery (2 x 12v) 24 volt	2 x 60 A
Running period	Approx 30 hours
Rear-wheel drive	700 Watt
Suction pads	4 unit Ø 300 mm

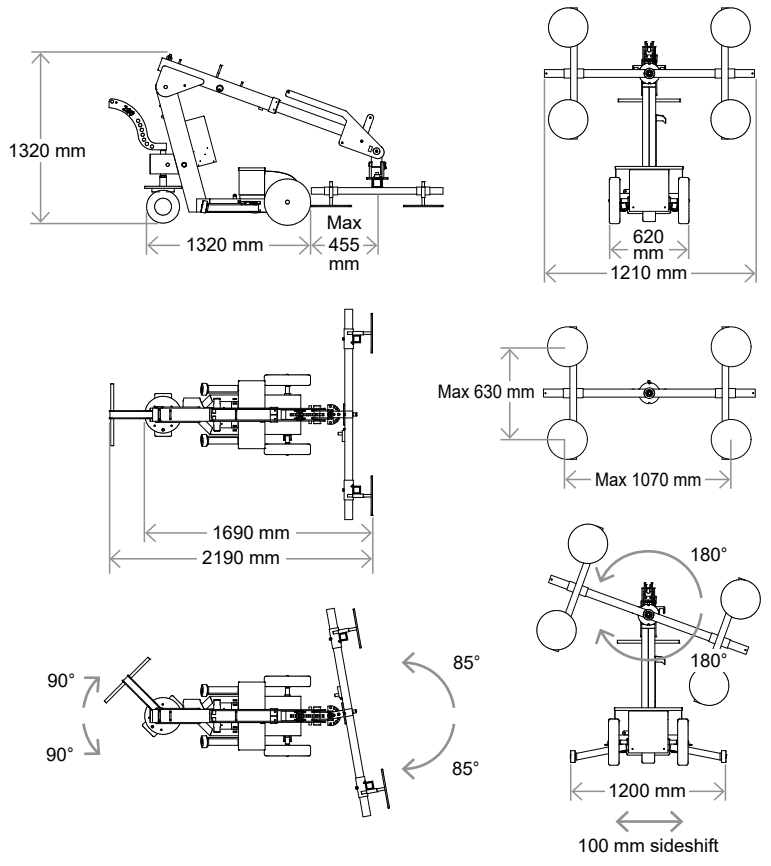
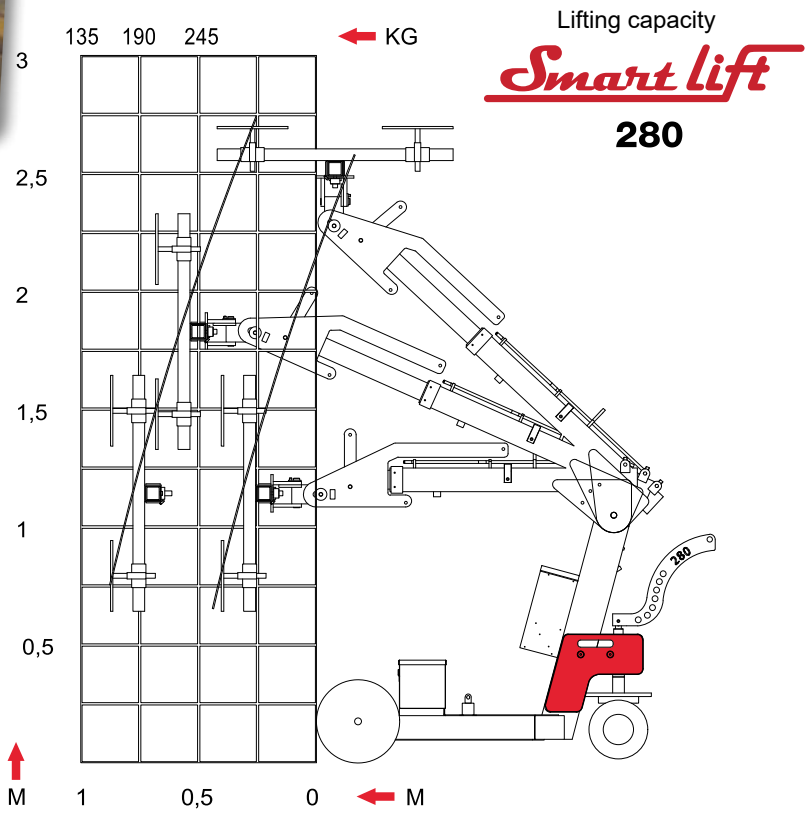

N.A. Christensensvej 39
 DK-7900 Nykøbing Mors
 Tel.: +45 97 72 29 11
 E-mail: smart@smartlift.dk
 www.smartlift.dk