

HD 10/25 S

HD 10/25 S Plus

HD 13/18 S Plus

HD 10/25 SX Plus

HD 13/18 SX Plus

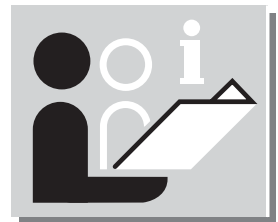

Deutsch



English



Français



Italiano



Español



Svenska



Polski



Русский



HD 10/25 S
HD 10/25 S Plus
HD 13/18 S Plus

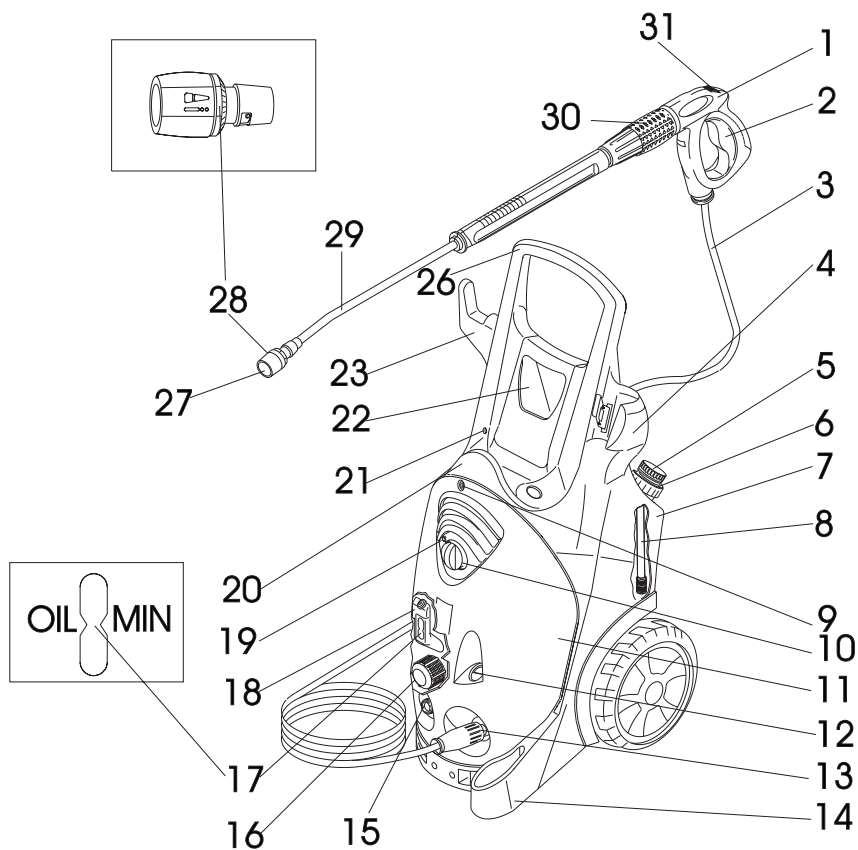
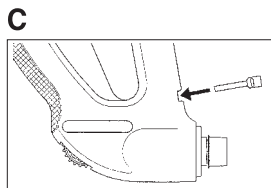
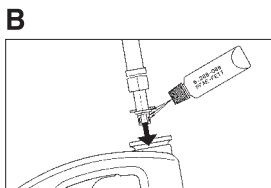
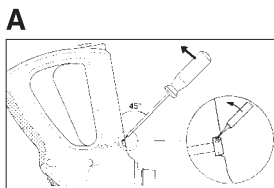

HD 10/25 SX Plus

HD 13/18 SX Plus

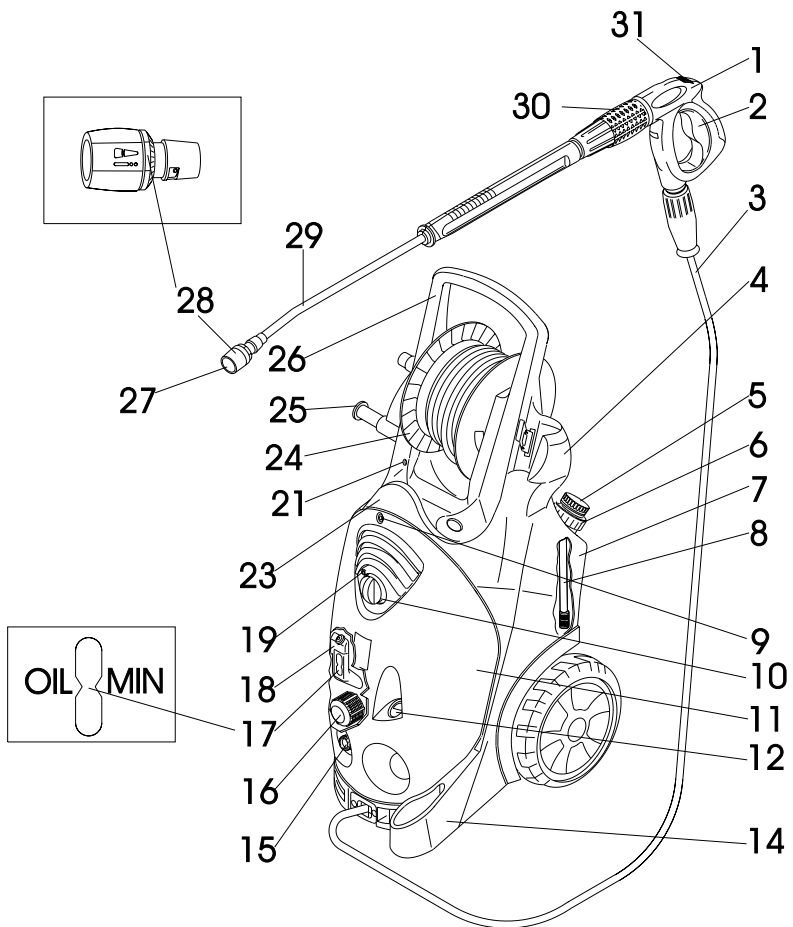

Unit components

Please fold out illustration page at the front

- 1 Hand-held spray gun
- 2 Lever of hand-held spray gun
- 3 High-pressure hose
- 4 Handgun support
- 5 Detergent metering valve
- 6 Cap for detergent reservoir
- 7 Detergent reservoir
- 8 Detergent suction-hose with filter
- 9 Fastening screw for hood
- 10 Unit switch
- 11 Hood
- 12 Pressure gauge
- 13 High-pressure outlet
- 14 Nozzle rest
- 15 Water connection
- 16 Fine filter
- 17 Oil level display
- 18 Oil reservoir
- 19 Indicator light
- 20 Hose rest
- 21 Detergent reservoir vent
- 22 Accessories box
- 23 Cable holder
- 24 Hose reel
- 25 Crank handle
- 26 Handle
- 27 Nozzle
- 28 Marking of the nozzle
- 29 Spray lance
- 30 Pressure/flow control
- 31 Safety catch of hand-held spray gun

For your safety

Before you use the cleaner for the first time, read these operating instructions and take special note of the accompanying booklet "Safety Instructions for High-Pressure Cleaners" No. 5.951-949.

Use of the cleaner

Use this unit exclusively for

- cleaning with high-pressure jet and detergent (e.g. cleaning of machines, vehicles, buildings, tools),
- cleaning with high-pressure jet without detergent (e.g. cleaning facades, terraces, gardening equipment).

For stubborn dirt we recommend the dirt blaster as an optional accessory.

Safety features

Relief valve with pressure switch

On reducing the flow rate with the pressure and flow control, the relief valve opens and part of the water runs back to the suction side of the pump.

If the lever of the hand-held spray gun is released, the pressure switch switches the pump off. If the lever is retracted, the pressure switch switches the pump on again.

The overflow valve and pressure switch have been set and sealed at the factory.

Adjustments are made only by Customer Service.

Preparing the unit for use

Unpack the unit

- When unpacking the unit, check the contents of the packaging. If there has been any damage in transit inform the dealer.
- Do not dispose of the packaging with the household rubbish, hand it in at the appropriate collection point for recycling.

Check the oil level

- Read the oil level displayed while unit is at a standstill. The oil level must be above the two indicators.

Activate the oil reservoir vent

- Unscrew the fastening screw of the hood and remove the hood.
- Cut off the tip on the cover to the oil reservoir.
- Fasten the unit cover.

Mount the accessories

- Mount nozzle on the spray lance (see markings on the top of the setting ring).
- Fit the spray lance to the hand-held spray gun with pressure and flow control.

For appliances with hose reel:

- Insert the crank handle into the hose drum shaft.
- Connect the high-pressure hose to the handgun.

For appliances without hose reel:

- Lock cable clincher into bore lateral to the handle.

For handguns with threaded connection:

- Tighten the high-pressure hose accordingly.

For handguns without threaded connection:

- Lever off retaining clasp on handgun with a screwdriver.
- Stand handgun on end and while holding it in this position, push end of hose into pistol as far as end stop. Ensure that loose disc on end of hose drops all way to bottom.
- Push retaining clasp back into handgun. When attached properly, high-pressure hose can only be pulled out by approx. 1 mm. If hose can be pulled out further, the disc has been incorrectly fitted.
- It is advisable to lay the high-pressure hose out in a straight line before reeling it up.
- Wind the high-pressure hose up in even layers on the hose reel by turning the crank handle.

Switching on the unit

Electrical connection



Caution!

The voltage specified on the model rating plate must correspond to the voltage supplied.



Caution!

The maximum tolerable mains impedance at the electrical contact point (see Technical Data) must not be exceeded.



Caution!

Use an extension cable with a sufficient cable cross-section (see Technical Specifications) and unwind it fully from the cable drum. For connected loads see model rating plate/ Technical Specifications.



Caution!

It is essential that the unit is connected to the power supply by means of a plug. An inseparable connection to the power supply is prohibited. The plug is used to disconnect from the mains.

Water connection/Suction feed operation

Connection to water main



Caution!

Pay attention to the regulations of the water supply company; according to DIN 1988, the unit may not be connected direct to the public drinking water supply. A short-term connection via a non-return valve (Order no. 6.412-578) is allowed.

For connected loads see Technical Specifications.

- Connect a supply hose (not supplied) to the water outlet on the unit and to the water inlet (e.g. water tap).
- Open water inlet.

Suctioning water from an open container

- Screw suction hose with filter (Order no. 4.440-238) to the water outlet.
- Vent the unit before using.
- To evacuate air from the unit, unscrew the nozzle and leave the unit running until water exits with no air bubbles.
- Switch off the unit and screw the nozzle back on.

Operating the unit



Danger!

Observe the relative safety regulations when using the unit at filling stations or other high-risk areas.



Caution!

Only clean engines in places which have appropriate oil separators (protection of the environment).



Caution!

Only wash animals with the low-pressure fan jet (see "Selecting the type of spray").

Operating with high pressure

The unit is equipped with a pressure switch. The motor only starts up when the lever is retracted.

- Unwind the high-pressure hose fully from the cable drum.
- Set the unit switch to "I". The indicator light will go green.
- Unlock the hand-held spray gun and retract the lever of the gun.
- Adjust operating pressure and flow rate (+/-) by rotating the pressure/flow control (infinitely variable).
- At the lowest flow rate the waste heat from the motor will heat the water to approx. 15 °C.

Selecting the type of spray

The handgun must be closed.

- Rotate the housing of the nozzle until the desired symbol corresponds with the marking.
- Select pencil jet or fan jet by contactless changeover: rotate the spray lance, which is pointing down at an angle of approx. 45°, to the left or right.

Explanation of the symbols



High-pressure pencil jet (0°), for particularly stubborn accumulation of grime.

High-pressure fan jet (25°), for dirt accumulation over a large surface.

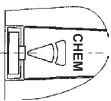

Low-pressure fan jet (CHEM) for operation with detergent or for cleaning at low pressure.

Operating with detergent



Caution!

Unsuitable detergents can harm the cleaner and the object which is to be cleaned. Use only detergents which are released by Kärcher. Proportions of detergent to be used and accompanying instructions should be noted carefully. Use detergents sparingly out of consideration for the environment.

Kärcher cleaning agents guarantee trouble-free operation. Please seek advice or ask for our catalogue of information sheets on cleaning agents.

- Fill detergent reservoir.
- Set nozzle to .
- Set the detergent metering valve to the desired concentration.

Concentration of detergent when flow at maximum:

Position of metering valve	1	3	5	7
	0.5 %	2.5 %	5.0 %	7.0 %

Recommended cleaning methods

- Spray detergent with low pressure jet sparingly over the dry surface to be cleaned and let it take effect but not dry out.
- Spray off (rinse off) the loosened dirt using the high-pressure spray.
- When you have finished the operation, set detergent metering valve to "0" and switch the unit on for about 1 minute and rinse it clear of detergent.

Interrupting the operation

- Release lever of the handgun, the unit switches off. Retract lever again and the unit switches on again.

Availability time

Within the availability time, the unit starts when the hand-held spray gun is opened. The indicator light will go green.

If the spray gun remains closed for 30 minutes, the availability time ends. The indicator light will flash green.

Reset availability time

- Switch off the unit switch.
- Wait a moment.
- Switch the unit back on again.

Customer Service can change the unit to permanent operation.

Switching the unit off

- Set unit switch to "0" and pull out power plug.
- Close water inlet.
- Retract lever until the unit is without pressure.
- Push safety catch of the hand-held spray gun forward to lock the lever of the gun from being actuated inadvertently.

 **Danger!** *Risk of scalding due to hot water. Residual water contained in the switched off unit can heat up. When removing the hose from the water inlet, the heater water can spurt out and cause scalds. Do not remove the hose until the unit has cooled down.*

Transporting the cleaner

- To transport the cleaner over relatively long stretches, take hold of it by the handle and pull it along behind you.
- Empty the detergent reservoir before transporting it horizontally.

Storing the cleaner

- Place the handgun in the support.
- Reel in the high-pressure hose and hang it over the hose rest.

or

- Wind the high-pressure hose on to the hose reel. Push in the crank handle to lock the hose drum.
- Coil the connecting cable round the cable/hose rest.

Frost protection

 **Caution!** *Frost will destroy a unit that is not completely empty of water! Store the unit where it will be free of frost.*

If storage away from frost is not possible:

- Empty the detergent tank (see care and maintenance/As and when required).
- Drain off the water and rinse the unit through with anti-freeze.
- Leave the unit to dry for max. 1 minute.
- Use the standard glycol-based anti-freezes for cars.
- Follow the handling instructions of the anti-freeze manufacturer.

Care and maintenance

 **Danger!** *Before any care and maintenance work on the unit draw out the mains plug.*

 **Caution!** *When changing the oil, dispose of any waste oil only at authorised collection points.*

Safety inspection/Maintenance contract

You can arrange with your dealer to have a regular safety inspection carried out or to have a maintenance contract. Please seek advice.

Before each use

- Check connecting cable for damage (risk of getting an electric shock), have a damaged connecting cable replaced without delay by authorised Customer Service personnel or an electrician.
- Check high-pressure hose for damage (danger of explosion), replace a damaged high-pressure hose without delay.
- Check unit (pump) for any leaks. Three drops per minute are allowable and can appear on the underside of the unit. Seek the help of Customer Service if leaks are more serious.

Every week

- Check oil level in oil reservoir: if the oil is milky (water in oil), seek the help of Customer Service immediately.
- Clean the fine filter.
 - Unpressurize unit.
 - Unscrew the fastening screw of the hood and remove the hood.
 - Unscrew the cover with filter.
 - Clean the filter with clean water or compressed air.
 - Reassemble in the reverse order.
- Clean the filter at the suction hose for detergent.

Annually or after 500 operating hours

- Change the oil
 - For oil quantity and type see Technical Specifications.
 - Undo the fastening screw, remove the hood, unscrew the front oil drain plug on the motor housing.
 - Drain oil into a suitable container.
 - Screw in the oil drain plug.
 - Fill slowly with fresh oil; air bubbles have to escape.

As and when required

- Emptying and cleaning the detergent tank
 - Pull out the screw cap and hose for the detergent tank.
 - Place the unit on its rear.
 - Empty and clean the detergent tank.

Troubleshooting



Danger!

Before any repair work is undertaken, switch the unit off and pull out the power plug. Have electrical components checked and repaired only by authorised Customer Service personnel.

For faults which are not identified in this chapter, or when in doubt or when expressly instructed to do so, consult authorised Customer Service personnel.

Indicator light

The indicator light shows the operating status (green) and faults (red).

To reset:

- Switch off the unit switch.
- Wait a moment.
- Switch the unit back on again.

Operating status display

- Constant green light:
 - Unit is operational.
- 1 x flashing green:
 - Operational readiness expired after 30 minutes.
 - The unit switched off after 30 minutes of permanent operation (safety feature in the case of a burst high-pressure hose).

Fault display

- 1 x flashing red:
 - High-pressure side leaking. Check high-pressure hose, hose connections and hand-held spray gun for leaks.
- 2 x flashing red:
 - Motor too hot. Switch off the unit switch. Leave unit to cool down. Switch the unit back on again.
- 3 x flashing red:
 - Fault in the power supply. Check the mains connection. Check supply fuses.
- 4 x flashing red:
 - Current consumption too high. Consult Customer Service

Unit does not work

- Availability time has run out. The indicator light will flash green. Switch the unit off and then on again.
- Check connecting cable for damage.
- Consult Customer Service if there is an electrical fault.

Unit does not come up to pressure

- Set nozzle to "high pressure".
- Clean/replace nozzle.
- Clean the fine filter, replace if required.
- Evacuate air from the cleaner (see Switching on the unit).
- Check water inlet volume (see Technical Specifications).
- Check all supply lines to the pump for leaks or obstructions.
- Seek the help of Customer Service if necessary.

Pump is leaky

- Three drops per minute are allowable and can appear on the underside of the unit. Seek the help of Customer Service if leaks are more serious.

Pump makes a knocking noise

- Check all supply lines as well as the detergent system for leaks.
- Evacuate air from the cleaner (see Switching on the unit).
- Clean the fine filter.
- Seek the help of Customer Service if necessary.

Detergent is not being drawn in

- Set nozzle to "Chem".
- Check detergent suction hose with filter for leaks or obstructions and clean it if necessary.
- Clean/renew non-return valve in detergent suction-hose connection.
- Open detergent metering valve or check it for leaks/remove obstruction. Also clean the venting orifice in the housing.
- Seek the help of Customer Service if necessary.

Spare parts

You will find a list of spare parts at the end of these operating instructions.

Warranty

The warranty terms issued by our authorised marketing company are valid in every country. We remedy any fault in the unit free of charge within the warranty period providing the cause of the fault proves to be a material or manufacturing error.

The warranty only becomes operative when your dealer has completed the reply card accompanying the sale of the unit, has stamped and signed it and you have then sent the reply card to the marketing company in your country.

Should you wish to call upon the guarantee, please apply to your dealer or nearest authorised Customer Service centre taking along also the accessories and bill of sale.

EU Declaration of Conformity

We hereby declare that the equipment described below conforms to the relevant fundamental safety and health requirements of the appropriate EU Directives, both in its basic design and construction as well as in the version marketed by us.

This declaration will cease to be valid if any modifications are made to the machine without our express approval.

Product: **High-pressure cleaner**

Type: **1.286-xxx, 1.292-xxx**

Relevant EU Directives:

EU Machinery Directive (98/37/CE)

EU Low-Voltage Equipment Directive (73/23/EEC) amended by 93/68/EEC

EU Directive on Electromagnetic Compatibility (89/336/EEC) as amended by 91/263/EEC, 92/31/EEC, 93/68/EEC,

EU Directive on Noise Emissions (2000/14/EU)

Harmonised standards applied:

DIN EN 60.335-1

DIN EN 60.335-2-79

DIN EN 55 014 -1 : 2000 + A1 : 2001

DIN EN 55,014-2:1997

DIN EN 61 000-3-2: 2000

DIN EN 61 000-3-11: 2000

National standards applied: –

Conformity evaluation procedure applied:

Appendix V

Measured sound power level:

HD 10/25 HD 13/18

85 dB(A) 85 dB(A)

Guaranteed sound power level:

HD 10/25 HD 13/18

87 dB(A) 87 dB(A)

i.V. Reiser H. Jenner

S. Reiser

H. Jenner

Alfred Kärcher GmbH & Co. KG

Cleaning Systems

D-71349 Winnenden

Alfred Kärcher Kommanditgesellschaft.

Sitz Winnenden;

Registergericht: Waiblingen, HRA 169.

Persönlich haftende Gesellschafterin: Kärcher

Reinigungstechnik GmbH; Sitz Winnenden,

2404 Registergericht Waiblingen, HRB

Geschäftsführer: Dr. Bernhard Graf, Hartmut Jenner,

Georg Metz

Technical Specifications

		HD 10/25 S			
		HD 10/25 S Plus		HD 13/18 S Plus	
		HD 10/25 SX Plus		HD 13/18 SX Plus	
Mains connection		EU	EU	EU	EU
Voltage	V	400/420	230	400	230
Type of current	Hz	3~50	3~50	3~50	3~50
Connected load	kW	9.2	9.2	9.2	9.2
Supply fuse (delayed-action, char. C)	A	16	25	16	25
Max. tolerable mains impedance	Ω	(0.145 + j0.090)		(0.145 + j0.090)	
Extension cable 10 m	mm ²	2.5	2.5	2.5	2.5
Extension cable 30 m	mm ²	4	–	4	–
Water connection					
Supply temperature max.	°C	60		60	
Supply volume min.	l/h (l/min)	1,200 (20)		1,400 (23.3)	
Supply hose – minimum length	m	7.5		7.5	
Supply hose – minimum diameter	inches	3/4		3/4	
Suction height from an open container 20 °Cm		0,5		0,5	
Supply pressure max.	MPa (bar)	1 (10)		1 (10)	
Performance data					
Operating pressure	MPa (bar)	3–25 (30–250)		3–18 (30–180)	
Max. operating overpressure (safety valve)	MPa (bar)	27,5 (275)		19,8 (198)	
Flow rate	l/h (l/min)	500–1,000 (8.3–16.7)		650–1,300 (8.3–21.7)	
Detergent intake	l/h (l/min)	0–80 (0–1.3)		0–80 (0–1.3)	
Recoil force of the handgun	N	62		68	
Sound emission					
Sound pressure level (EN 60704-1)	dB (A)	72		72	
Garanted sound pressure level (2000/14/EC)	dB (A)	87		87	
Vibrations of unit / total of vibration (ISO 5349)					
Handheld gun	m/s	2,2		2,2	
Spray lance	m/s	2,0		2,2	
Dimensions					
Length	mm	560		560	
Width	mm	500		500	
Height	mm	1,090		1,090	
Weight without accessories	kg	62		62	
Weight without accessories, HD SX	kg	64		64	
Reservoir capacity, detergent	l	6		6	
Oil quantity, pump	l	1.2		1.2	
Oil type, pump		SAE 90		SAE 90	

HD 10/25 S

HD 10/25 S Plus

HD 13/18 S Plus

