

SR21A

SR21A-J



For unsurpassed outreach and flexibility,
choose Aichi SR21A / SR21A-J
aerial platform from Aichi Skymaster.

- Max. Platform Height: 21.0m
- Max. Load Capacity: 227kgs

New HV Control System as STD.

Operator can easily maneuver the Aichi SR21A / SR21A-J by HV control system.

Both the SR21A and SR21A-J are equipped with horizontal and vertical movement control(HV control) as standard which permits the operator to move the basket straight in a vertical and horizontal direction at the same time with a single lever operation.

18.6m Horizontal Outreach(SR21A)

17.8m Horizontal Outreach(SR21A-J)

Aichi SR21A/SR21A-J has the greatest outreach in its class.

Smoother / Safer

Aichi's improved computer system provides for smoother and safer operation. On the job site, operator is supported and protected by "Travel speed control", "Rotation speed control", "Lifting speed control" at all time.

Crawler with high traveling performance

It demonstrates excellent traveling performance on any road condition at the site, especially uneven ground.

By adopting the pivot turn and spin turn mechanism, a feature of the crawler, it can make a sharp turn even at a relatively narrow site and demonstrates a high mobility.



Specifications	SR21A-J	SR21A
Reach Specifications		
Platform Height	21.0m	
Horizontal Outreach	17.8m	18.6m
Swing	360degree,Continuous	
Platform Capacity	227kgs	
Platform Rotator	180degree(90,90)	
Jib Range of Articulation	130degree(+70,-60)	N/A
Dimension Data		
A. Platform Size	1.8m x 0.75m(Std), 2.4m x 0.75m(Opt)	
B. Overall Width	2.46m	
C. Tailswing	1.13m	
D. Overall Height	2.35m	
E. Overall Length	11.57m	10.15m
F. Tumbler center distance	2.575m	
G. Ground Clearance	0.425m	
Gross Vehicle Weight	15,200kgs	14,900kgs
Chassis		
Traveling Speed	2.0km/h	
Gradeability stowed	48% (26 degrees)	
Power Source		
Diesel Engine	Isuzu A 4JB1, PAA-22 44.3KW/2,400rpm	
Fuel Tank Capacity	150liter	
Safety Features		
H-V Control	STD	
Travel Speed Control	STD	
Rotation Speed Control	STD	
Lifting Speed Control	STD	
All Motion Alarm	STD	
Lever Guard	STD	

*These specifications and appearance are subject to change for improvement without notice.

AICHI CORPORATION

International Division

1152,Ryoke,Ageo,Saitama 362-8550,Japan

Tel:+81-48-781-1671 Fax:+81-48-781-1808

E-mail:aichi@tky.3web.ne.jp

< Distributor >

SR21A-J

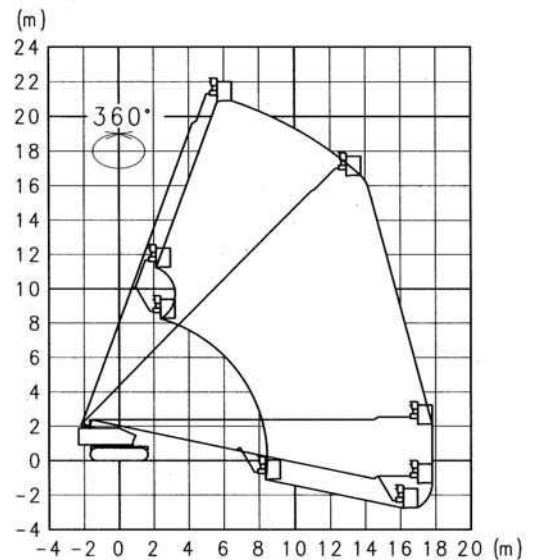
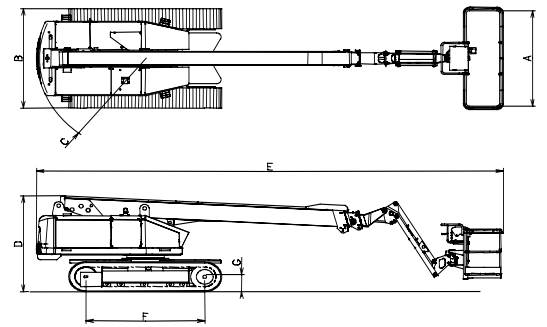

SR21A

