

Moving runner

Ref. : R.CF2

Product picture



Technical drawing

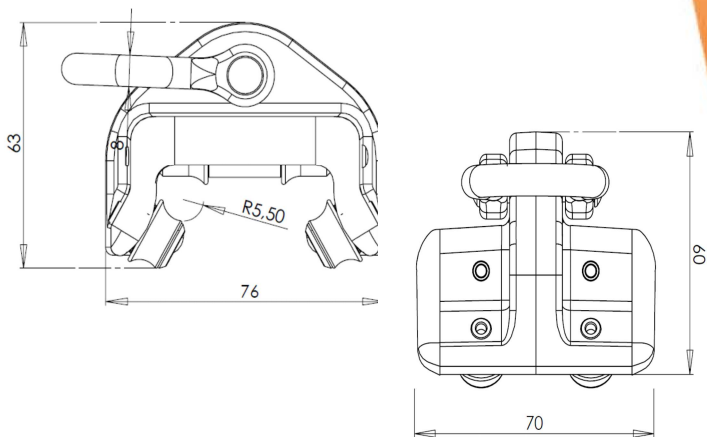

Assembly principle

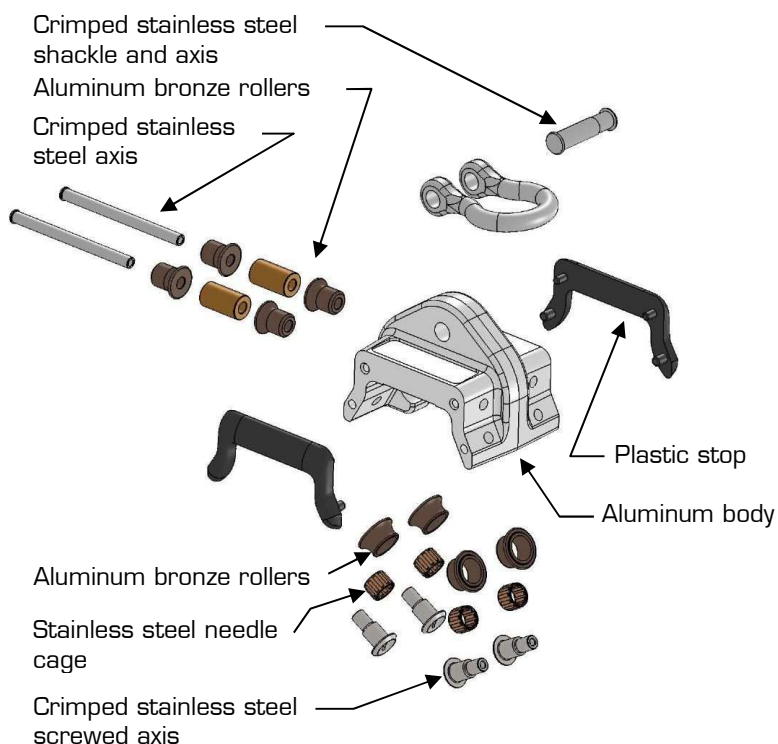

Technical features

Material
 Body : aluminum
 Axis and shackle : stainless steel
 Rollers : aluminum bronze
 Finish : black cataphoresis
 Weight : 420 g

Mounting features

The runner can be permanently installed on the rail or can be introduced thereon by one end fitted with a retractable end stop.

Advantages

The one-piece body with two safety hooks ensures a high level of security.
 The combination of two types of rollers allows good circulation of the runner in all installation configurations.